

The Role Of Public Health Models In Policymaking

BHASHKARAN NAIDOO

London School of Hygiene and Tropical Medicine

A Thesis Submitted for the Degree of Ph.D. of the University of London

Abstract

Aims: To evaluate the use of public health models in policymaking, with regard to the appropriateness and the practicalities of using such models for simulating health interventions, and the application of the results of such modelling exercises to public health policymaking.

Methods: In conjunction with policymakers, existing public health models were adapted and used for simulating the effects of risk factor interventions on CHD in the England & Wales population. These models were evaluated in terms of the limitations of the input data, the assumptions underlying the methodology of the models, and problems in translating interventions to the simulation environment.

Results: The simulation of CHD risk factor interventions using the Prevent and POHEM models demonstrated how public health models can be used with policymakers to estimate the future development of the health of populations; to evaluate alternative routes to achieving health goals; to demonstrate the effect of targeting health interventions at different sections of a population; to investigate the relationship between risk factors and their linked diseases; and for demonstrating the possible effect of health interventions to health practitioners.

Conclusions: Public health models can be used as policy tools, although ultimately they may only inform policy, and not drive it, due to other factors which can influence the policy agenda. Such models are complex instruments that require a long term commitment in terms of funding, and they need to be developed by multidisciplinary teams, whose expertise cover the areas of computing, epidemiology and health policy, but most importantly policymakers should be involved with their development and use. Although public health models may never be validated in terms of a “gold standard”, they can be used as policy tools as long as one is aware that they are unverified and that they yield results of a hypothetical nature.

Table of Contents

Title Page	1
Abstract	2
Table of Contents	3
List of Tables	13
List of Figures	15
Preface	21
Section 1: Literature Review	23
Chapter 1 - Simulation Models and Public Health Modelling	24
1.1 Introduction	24
PART I	25
1.2 Definitions	25
1.3 Types of Model	26
1.4 Policy Models	27
PART II	29
1.5 Review of CHD Policy Models	29
1.5.1 <i>Cell-based Models</i>	29
1.5.2 <i>Micro-simulation Models</i>	30
1.6 Prevent	31
1.7 The Coronary Heart Disease Policy Model	33
1.8 The Netherlands Integrated Model of Public Health	34
1.9 Prevent Plus	36
1.10 The Population Health Model	37
1.11 The Chronic Disease Risk Intervention Simulation Program for Epidemiological Research Studies	39
1.12 The Global Burden of Disease Model	40
1.13 Applying Models to the England & Wales Population	42

Chapter 2 - Policy Decisions in Public Health	43
2.1 Introduction	43
2.1.1 <i>The Concepts of Health, Public Health and Health Policy</i>	43
2.2 Public Health Models	45
2.3 Issues In Current Health Policy	49
2.4 The Link Between Research Evidence And Policy Making	50
2.4.1 <i>The Rational Model of Research and Policy Development</i>	51
2.5 Problems in the Relationship Between Research and Policy	53
2.5.1 <i>The Realistic Model of Research</i>	54
2.5.2 <i>The Incremental Model</i>	55
2.6 The Role of Mathematical Modelling as an Aid to Policy Making	56
Chapter 3 – Health Policy in England Since 1995	57
3.1 Introduction	57
3.2 The Health of The Nation Targets	58
3.3 Saving Lives: Our Healthier Nation	60
3.4 Independent Inquiry into Inequalities in Health Report	63
3.5 The Effect of Targets on the Policy Agenda	64
3.6 The Implication of Targets for Modelling	65
Chapter 4 - Data Sources	67
4.1 Introduction	67
4.2 Census Data	67
4.3 National Population Projections	68
4.4 Mortality Statistics	68
4.5 General Household Survey	69
4.6 Health Survey For England	70
4.7 Allied Dunbar National Fitness Survey	71
4.8 Morbidity Statistics from General Practice	72
4.9 Hospital Episode Statistics	73
4.10 Cancer Registration	74

4.11	Oxfordshire Stroke Register	75
4.12	Scottish MONICA Data	76
4.13	Discussion	78
4.14	Conclusion	80
Section 2: PREVENT		81
Chapter 5 – The PREVENT Model		82
5.1	Introduction	82
5.2	Getting Started With PREVENT	82
	5.2.1 <i>Installation</i>	82
5.3	PREVENT Input Data Files	83
	5.3.1 <i>Model Settings Files</i>	83
	5.3.2 <i>Population Data</i>	84
	5.3.3 <i>Risk Factor Data</i>	85
	5.3.4 <i>Cause Specific Mortality Data</i>	86
5.4	PREVENT Output	86
	5.4.1 <i>Disease Specific Output</i>	86
	5.4.2 <i>Aggregated Output</i>	87
5.5	Adapting PREVENT	88
5.6	Validation	89
5.7	Discussion	89
5.8	Summary	90
Chapter 6 - PREVENT Trends And Limitations		91
6.1	Introduction	91
PART I		91
6.2	PREVENT Trends	91
6.3	Calculating Past Trends	93
	6.3.1 <i>Cohort Specific Risk Factor Trends</i>	93
	6.3.2 <i>An Alternative Method of Calculation</i>	98

6.3.3	<i>Age Group Specific Risk Factor Trends</i>	100
6.3.4	<i>Future Trends</i>	101
6.4	Spreadsheet Implementation	101
6.5	Discussion of Trends	102
PART II		103
6.6	PREVENT Limitations	103
6.6.1	<i>Shifting Risk Factor Exposure</i>	103
6.6.2	<i>Relative Risks Less Than One</i>	105
6.6.3	<i>Univariate Risk Factor Distributions</i>	107
6.7	Discussion of Limitations	108
6.8	Summary	108
Chapter 7 - Modelling the Effects of Increased Physical Activity Using		
	The PREVENT Model	109
7.1	Introduction	109
7.2	Health Benefits of Physical Activity	109
7.2.1	<i>Measurement of Physical Activity</i>	111
7.3	Current Activity Levels In The Population	111
7.4	Initial Physical Activity Targets	113
7.4.1	<i>Threshold or Graded Effect of Physical Activity</i>	114
7.5	Initial Exercise Interventions	114
7.5.1	<i>Initial Scenarios</i>	115
7.6	Adapting PREVENT	116
7.6.1	<i>Adapting the Relative Risks Estimates</i>	117
7.7	Limitations Of PREVENT	121
7.8	Model Assumptions	122
7.9	Initial Intervention Outputs	124
7.10	Initial Results	124
7.10.1	<i>Threshold Versus Graded Effect</i>	124
7.10.2	<i>Reduction in CHD Death Rate</i>	124
7.10.3	<i>Reduction in Total Mortality and Life Years Gained</i>	125

7.10.4	<i>Age Groups</i>	125
7.11	Discussion of Initial Results	126
7.12	Final Exercise Interventions	127
7.12.1	<i>Revised Strategies</i>	127
7.13	Final Intervention Outputs	128
7.14	Final Results	129
7.14.1	<i>Sensitivity Analysis</i>	131
7.15	Discussion	133
7.16	Reflections	135
7.17	Conclusions	136
7.18	Summary	137
 Chapter 8 - Birmingham Interventions Modelled With PREVENT		138
8.1	Introduction	138
8.2	Choosing a Version of PREVENT to Adapt	138
8.3	Adaptation of PREVENT	139
8.3.1	<i>Importance of Ethnic Mix</i>	141
	STAGE ONE	142
8.4	Initial Meeting	142
8.5	Choosing the Interventions	143
8.6	Running the Model	145
8.7	Results of the Modelling	146
8.7.1	<i>Birmingham Simulations</i>	146
8.7.2	<i>Small Heath and Sutton Coldfield Simulations</i>	151
8.8	Discussion	159
8.9	Presentation of Results to Birmingham Health Regional Authority	160
	STAGE TWO	163
8.10	Revised Specifications for the Modelling	163
8.11	Simulations	164
8.12	Results of the Modelling	165
8.12.1	<i>Birmingham Simulations</i>	165

8.12.2	<i>Small Heath and Sutton Coldfield Simulations</i>	169
8.13	Discussion	176
8.14	Reflections	177
8.15	Conclusions	180
8.16	Summary	181
Chapter 9	– PREVENT European Collaborative Project	183
9.1	Introduction	183
9.2	Four E.U. Versions of PREVENT	184
9.3	Population Data	185
9.3.1	<i>Base Year</i>	185
9.3.2	<i>General Mortality</i>	185
9.3.3	<i>Disease Specific Mortality</i>	186
9.4	Risk Factors	186
9.4.1	<i>Choice of Risk Factors</i>	186
9.4.2	<i>Risk Factor Classification</i>	187
9.5	Relative Risks, Remnant Relative Risks, LAT and LAG Times	188
9.5.1	<i>Smoking</i>	188
9.5.2	<i>Hypertension</i>	189
9.5.3	<i>Hypercholesterolaemia</i>	189
9.6	Country Specific Data for the England & Wales Version of PREVENT	190
9.6.1	<i>Population Data</i>	190
9.6.2	<i>Risk Factor Data</i>	191
9.7	Modelling Smoking Interventions Across Four E.U. Countries	191
9.8	Discussion	194
9.9	Summary	196
Chapter 10	- The Development of PREVENT Version 2.8	198
10.1	Introduction	198
10.2	PREVENT Version 2.8	198
10.3	PREVENT Plus	200

10.4	Discussion	202
10.5	Summary	203
Chapter 11 – Discussion of the PREVENT Model		204
11.1	Introduction	204
11.2	Positive Aspects of PREVENT	204
11.3	Limitations of PREVENT	205
11.4	Conclusions	207
Section 3: POHEM		209
Chapter 12 - POPULATION HEALTH MODEL (POHEM)		210
12.1	Introduction	210
12.2	Development of POHEM	213
12.3	Using POHEM	216
12.4	Running POHEM	220
12.5	Overview of POHEM	220
12.6	Summary	221
Chapter 13 - Developing The England & Wales POHEM		222
13.1	Introduction	222
13.2	Data Requirements	223
	<i>13.2.1 Data Sources</i>	223
	<i>13.2.2 Data Input</i>	224
13.3	Output	225
	<i>13.3.1 Mortality Output</i>	225
	<i>13.3.2 Morbidity Output</i>	226
13.4	Summary	226

Chapter 14 - Using The Framingham Equation With The Population of	
England & Wales	227
14.1 Introduction	227
14.1.1 <i>The Framingham Study</i>	227
14.1.2 <i>The Framingham Equation</i>	228
14.2 Generalisability	229
14.3 Problem of Validation	229
14.4 Review of the Literature	230
14.4.1 <i>Leaverton et al</i>	230
14.4.2 <i>Chambless et al</i>	231
14.4.3 <i>Assman et al</i>	231
14.4.4 <i>Laurier et al</i>	232
14.4.5 <i>Grover et al</i>	232
14.4.6 <i>Liao et al</i>	233
14.4.7 <i>Wilson et al</i>	233
14.4.8 <i>Grundy et al</i>	234
14.4.9 <i>Hingorani et al</i>	234
14.4.10 <i>Durrington et al</i>	235
14.4.11 <i>Haq et al</i>	236
14.4.12 <i>Statistics Canada</i>	236
14.5 Discussion of the Framingham Equation	237
14.6 Summary	238
Chapter 15 – A Comparison of the POHEM and PREVENT Models	239
15.1 Introduction	239
15.2 Differences Between Prevent and POHEM	239
15.2.1 <i>Cohort Versus Population Model</i>	239
15.2.2 <i>Shifting Risk Factor Exposure</i>	240
15.2.3 <i>Univariate Versus Multivariate Risk Factor Distributions</i>	240
15.2.4 <i>Relative Risks Versus the Framingham Equation</i>	241
15.2.5 <i>Past and Future Trends Versus Present Trends</i>	241

15.3	Interventions	242
15.4	Output	244
	<i>15.4.1 Mortality Output</i>	244
	<i>15.4.2 Morbidity Output</i>	245
15.5	Initial Adaptation of POHEM	245
15.6	Results from the Initial Adaptation	246
15.7	Second Adaptation of POHEM	249
15.8	Results from the Second Adaptation	250
	<i>15.8.1 Comparing POHEM and Prevent Methodologies</i>	250
	<i>15.8.2 POHEM Specific Interventions</i>	253
15.9	Discussion of Results	257
	<i>15.9.1 Comparing POHEM and Prevent Methodologies</i>	257
	<i>15.9.2 POHEM Specific Interventions</i>	258
15.10	Discussion	259
	<i>15.10.1 Data Needs</i>	259
	<i>15.10.2 Generalising and Adapting the Models for Different Populations</i>	260
	<i>15.10.3 Flexibility in Addressing Additional Questions</i>	260
	<i>15.10.4 Interpretation</i>	261
	<i>15.10.5 General Discussion</i>	261
15.11	Reflections	262
15.12	Conclusions	263
15.13	Summary	263
Chapter 16	– POHEM Discussion	265
16.1	Introduction	265
16.2	Positive Aspects of POHEM	265
16.3	Limitations of POHEM	267
16.4	Conclusions	269

Section 4: Discussion	271
Chapter 17 – Discussion	272
17.1 Introduction	272
17.2 Model Development	273
17.2.1 <i>Review of Models</i>	273
17.2.2 <i>Prevent</i>	274
17.2.3 <i>POHEM</i>	278
17.2.4 <i>The Role of Policymakers in Model Development</i>	280
17.2.5 <i>Other Important Aspects of Model Development</i>	280
17.3 The Data Need of Models	281
17.4 The Policy Arena	283
17.5 The Potential Impact of Models on Policy	284
17.6 The Implications for Future Research	285
17.7 Conclusions	288
Section 5: References	293
Section 6: Appendices	320
Appendix A - Prevent Input Files	321
Appendix B - The Prevent Log File: DAT1INST.DAT	324
Appendix C - Moving on - International perspectives on promoting physical activity	326
Appendix D - Chapter 7: Tables of the Figures – Modelling the Effects of Increased Physical Activity Using the Prevent Model	339
Appendix E - Modelling the effects of increased physical activity on Coronary heart disease in England and Wales	340
Appendix F - Input Data for the Birmingham, Small Heath and Sutton Coldfield Versions of the Prevent Model	348
Appendix G - Estimates of several anti-tobacco policies in four European countries	367

List of Tables

Table 1.1 –	Prevent risk factors and causes of death	32
Table 1.2 –	Prevent restrictions	32
Table 1.3 –	Prevent Plus risk factors and causes of death	36
Table 4.1 -	Scottish MONICA coronary events by sex	77
Table 6.1 –	Risk factor prevalence and trends over time by age and age group	94
Table 6.2 –	Risk factor prevalence and trends over time by age and age group, with differing age groups	98
Table 6.3 –	Relative risks of disease mortality for alcohol as used by Prevent	105
Table 7.1 -	Prevalence of physical activity (20 minutes at least 3 times a week) for England and Wales by sex and age group	112
Table 7.2 -	Prevalence of physical activity (30 minutes at least 5 times a week) for England and Wales by sex and age group	113
Table 7.3 –	Independent relative risks of CHD mortality using a threshold and a graded hypothesis	114
Table 7.4 –	Number of studies reporting CHD outcomes by type of activity, as reported by Powell et al	119
Table 7.5 –	Summary of relative risks with 95% CI by type of study and level of activity compared to high activity for CHD and CHD death	119
Table 7.6 –	Relative risk of CHD mortality from Powell et al	120
Table 7.7 –	CHD mortality per 100,000 for males and females aged under 95 years achieving each strategy	129
Table 7.8 –	Modified relative risks of CHD mortality in relation to physical activity level and age group	131
Table 14.1 –	Multiple logistic function coefficients by sex and study	230

Table 14.2 – Estimated number of CHD events in the Helsinki Heart Study using equations from the Framingham and PROCAM studies, compared to the observed number of events	232
Table 14.3 – Effects of cholesterol lowering in primary prevention of cardiovascular disease in 55 year old men with hypercholesterolaemia: predictions by the Framingham computer program compared with observed risk reductions in WOSCOPS	235
Table 14.4 - Effects of cholesterol lowering in secondary prevention of cardiovascular disease: predictions by the Framingham computer program compared with observed risk reductions in the 4S and CARE trials	235
Table 14.5 – Summary of the methods used to investigate the generalisability of the Framingham equation	237
Table 15.1 - POHEM simulation output of a cigarette advertising ban using the Prevent and Framingham methodology models	255
Table 15.2 - POHEM simulation output of high risk and population intervention strategies	256

List of Figures

Figure 2.1 -	Health care activities dominate issues of health policy	46
Figure 2.2 -	Health policy of the 1970s and 1980s	47
Figure 2.3 -	Health policy after the Lalonde Report	48
Figure 6.1 –	Ageing of a cohort	93
Figure 6.2 –	Ageing of a birth cohort	95
Figure 6.3 –	Ageing of a cohort with age groups specific risk factor Trends	100
Figure 6.4 –	Movement between exposure categories under Prevent's original and adapted methodologies	104
Figure 6.5 –	Relative risk close to zero	106
Figure 7.1 –	Actual years of life gained for men and for women aged under 95 achieving each strategy by 2019	130
Figure 7.2 –	Actual years of life gained for men and for women aged under 95 achieving each strategy by 2019, targeting by age group	130
Figure 7.3 –	Actual years of life gained for men and for women aged under 95 achieving Strategy 1 by 2019, targeting by age group, using modified relative risk and using the cohort option	132
Figure 7.4 –	Actual years of life gained for men and for women aged under 95 achieving Strategy 2 by 2019, targeting by age group, using modified relative risk and using the cohort option	132
Figure 8.1 –	Actual years of life gained due to smoking interventions in Birmingham males	147
Figure 8.2 -	Actual years of life gained due to smoking interventions in Birmingham females	147
Figure 8.3 -	Actual years of life gained due to a 5% increase in the levels of moderate activity in the Birmingham population	148

Figure 8.4 -	Actual years of life gained due to a 10% increase in the levels of moderate activity in the Birmingham population	148
Figure 8.5 -	Actual years of life gained due to a 15% increase in the levels of moderate activity in the Birmingham population	149
Figure 8.6 -	Actual years of life gained due to a 20% screening and treating of hypertension in the Birmingham population	149
Figure 8.7 -	Actual years of life gained due to a 30% screening and treating of hypertension in the Birmingham population	150
Figure 8.8 -	Actual years of life gained due to a 40% screening and treating of hypertension in the Birmingham population	150
Figure 8.9 -	Actual years of life gained due to a 1% reduction in the prevalence of cigarette smoking in the Small Heath and Sutton Coldfield populations	152
Figure 8.10 -	Actual years of life gained due to a 2% reduction in the prevalence of cigarette smoking in the Small Heath and Sutton Coldfield populations	152
Figure 8.11 -	Actual years of life gained due to a 3% reduction in the prevalence of cigarette smoking in the Small Heath and Sutton Coldfield populations	153
Figure 8.12 -	Actual years of life gained due to a 5% increase in the levels of moderate activity achieved by targeting the sedentary in the Small Heath and Sutton Coldfield populations	153
Figure 8.13 -	Actual years of life gained due to a 5% increase in the levels of moderate activity achieved by targeting the lightly active in the Small Heath and Sutton Coldfield populations	154
Figure 8.14 -	Actual years of life gained due to a 10% increase in the levels of moderate activity achieved by targeting the sedentary in the Small Heath and Sutton Coldfield populations	154

Figure 8.15 - Actual years of life gained due to a 10% increase in the levels of moderate activity achieved by targeting the lightly active in the Small Heath and Sutton Coldfield populations	155
Figure 8.16 - Actual years of life gained due to a 15% increase in the levels of moderate activity achieved by targeting the sedentary in the Small Heath and Sutton Coldfield populations	155
Figure 8.17 - Actual years of life gained due to a 15% increase in the levels of moderate activity achieved by targeting the lightly active in the Small Heath and Sutton Coldfield populations	156
Figure 8.18 - Actual years of life gained due to a 20% screening and treating of hypertension targeting the severe hypertensives in the Small Heath and Sutton Coldfield populations	156
Figure 8.19 - Actual years of life gained due to a 20% screening and treating of hypertension targeting the mild hypertensives in the Small Heath and Sutton Coldfield populations	157
Figure 8.20 - Actual years of life gained due to a 30% screening and treating of hypertension targeting the severe hypertensives in the Small Heath and Sutton Coldfield populations	157
Figure 8.21 - Actual years of life gained due to a 30% screening and treating of hypertension targeting the mild hypertensives in the Small Heath and Sutton Coldfield populations	158
Figure 8.22 - Actual years of life gained due to a 40% screening and treating of hypertension targeting the severe hypertensives in the Small Heath and Sutton Coldfield populations	158
Figure 8.23 - Actual years of life gained due to a 40% screening and treating of hypertension targeting the mild hypertensives in the Small Heath and Sutton Coldfield populations	159

Figure 8.24 - Actual years of life gained due to smoking interventions with a 0% trend in the Birmingham population	166
Figure 8.25 - Actual years of life gained due to smoking interventions with a -3% trend in the Birmingham population	166
Figure 8.26 – Lung cancer mortality due to an increasing 15-24 age group smoking trend in the Birmingham population	167
Figure 8.27 – COLD mortality due to an increasing 15-24 age group smoking trend in the Birmingham population	167
Figure 8.28 – CHD mortality due to an increasing 15-24 age group smoking trend in the Birmingham population	168
Figure 8.29 – CVA mortality due to an increasing 15-24 age group smoking trend in the Birmingham population	168
Figure 8.30 - Actual years of life gained due to screening and treating of hypertension in the Birmingham population	169
Figure 8.31 - Actual years of life gained due to a –2% reduction in smoking with a 0% trend in the Small Heath and Sutton Coldfield populations	170
Figure 8.32 - Actual years of life gained due to a –3% reduction in smoking with a 0% trend in the Small Heath and Sutton Coldfield populations	171
Figure 8.33 - Actual years of life gained due to a –4% reduction in smoking with a 0% trend in the Small Heath and Sutton Coldfield populations	171
Figure 8.34 - Actual years of life gained due to a –3% reduction in smoking with a -2% trend in the Small Heath and Sutton Coldfield populations	172
Figure 8.35 - Actual years of life gained due to a –3% reduction in smoking with a -3% trend in the Small Heath and Sutton Coldfield populations	172

Figure 8.36 - Actual years of life gained due to a –4% reduction in smoking with a -3% trend in the Small Heath and Sutton Coldfield populations	173
Figure 8.37 - Lung cancer mortality due to an increasing 15-24 age group smoking trend in the Small Heath and Sutton Coldfield populations	173
Figure 8.38 - COLD mortality due to an increasing 15-24 age group smoking trend in the Small Heath and Sutton Coldfield populations	174
Figure 8.39 - CHD mortality due to an increasing 15-24 age group smoking trend in the Small Heath and Sutton Coldfield populations	174
Figure 8.40 - CVA mortality due to an increasing 15-24 age group smoking trend in the Small Heath and Sutton Coldfield populations	175
Figure 8.41 - Actual years of life gained due to a 20% screening and treating of hypertension targeting the mild hypertensives in the Small Heath and Sutton Coldfield populations	175
Figure 8.42 - Actual years of life gained due to a 40% screening and treating of hypertension in the Small Heath and Sutton Coldfield populations	176
Figure 12.1 – POHEM CHD Module	212
Figure 12.2 – POHEM diagrammatic: pre-compilation, compilation and running	215
Figure 12.3 – POHEM.EXE window	217
Figure 12.4 – POHEM.EXE with scenario file loaded	218
Figure 12.5 – POHEM.EXE: an example of modifiable variables in a data file	218
Figure 15.1 - Reduction In lung cancer deaths for England & Wales due to a cigarette advertising ban: Prevent Model versus POHEM	247

Figure 15.2- Reduction in COLD deaths for England & Wales due to a cigarette advertising ban: Prevent Model versus POHEM	247
Figure 15.3 - Reduction in CVA deaths for England & Wales due to a cigarette advertising ban: Prevent Model versus POHEM	248
Figure 15.4 - Reduction in CHD deaths for England & Wales due to a cigarette advertising ban: Prevent Model versus POHEM	248
Figure 15.5 - Reduction in lung cancer deaths for England & Wales due to a cigarette advertising ban: Prevent versus POHEM methodology	250
Figure 15.6 - Reduction in COLD deaths for England & Wales due to a cigarette advertising ban: Prevent versus POHEM methodology	251
Figure 15.7 - Reduction in CVA deaths for England & Wales due to a cigarette advertising ban: Prevent versus POHEM methodology	251
Figure 15.8 - Reduction in CHD deaths for England & Wales due to a cigarette advertising ban: Prevent versus POHEM methodology	252

Preface

I joined the Health Gain Project, based in the Health Promotion Research Unit at the London School of Hygiene and Tropical Medicine, in 1992. The aim of the Health Gain Project was to combine the expertise of statisticians, epidemiologists, economists and computer modellers to explore the effectiveness and resource implications of differing strategies for reducing the burden of coronary heart disease. The Project worked alongside policymakers within the National Health service, bringing academic knowledge to bear on the planning issues which faced practitioners.

It was felt that public health models could be useful in assessing the relative health gain of alternative routes to the attainment of strategic goals, such as *The Health of The Nation* targets, and would be helpful for applying epidemiology to decision making at a population level.

During the course of my work I realised that although such public health models were meant to be used as policy tools; they were often developed and used without input from policymakers. And so I thought it would be interesting to investigate the extent to which such modelling might be used for decision making, what were the issues which hindered their use, and whether an “ideal” public health model could be defined. In this thesis I discuss the issues that I think are important in terms of being able to use public health models for policymaking, as well as trying to answer the above questions.

Acknowledgements

I would most like to thank Dr. Margaret Thorogood, my supervisor and line-manager, for her help and support over the last eight years, particularly for giving me the confidence to pursue a Ph.D. degree, and for nagging me along the way to get it finished.

I would also like to thank the members of my advisory committee, Professor Klim McPherson and Professor Michel Coleman, for their input and advice on the early stages

of my work, and Professor Charles Normand for his continued interest in my modelling work throughout the period of the Health Gain Project.

In addition, I must thank Professor Louise Gunning-Schepers, Dr Jan Barendregt, Dr Luc Bonneux, Dr Michael Wolfson, Mr Jean-Marie Berthelot and Mr Bill Flanagan for their invaluable help and support with PREVENT and POHEM over the last six years, and for always being willing to answer my questions.

I dedicate this thesis to my parents, Jacky and Tholsie Naidoo, who have always been there for me and who have always supported my efforts along the way. I would never have got this far without you.

Section 1: Literature Review

v

Chapter 1 - Simulation Models and Public Health Modelling

1.1 Introduction

Usually the effectiveness of intervention strategies are evaluated by experimental or observational methods in longitudinal studies, such as randomised control trials or cohort studies. The results of these studies would be extrapolated to estimate the effect for a given population. Unfortunately the time-scales necessary for such studies can be prohibitive. This is particularly true for health promotion strategies which target risk factors for diseases with long latency periods, such as coronary heart disease (CHD). Current health care demands require policy decisions to be based on evidence, but the decisions must be made before there is time to collect evidence from observational studies.

In recent years the use of simulation models has been seen as a partial solution to the problem of the evaluation of health interventions, particularly in terms of interventions aimed at reducing the risk of non-communicable diseases (Morgenstern 1992 and Manton 1988). These computer models allow policymakers to simulate the effects of different scenarios within a population, using available data on existing risk factor prevalence, the related risks of disease morbidity and mortality, and the likely change in risk factor prevalence due to interventions, and then project the results over several generations. It is envisaged that these models will be useful in evaluating the relative health gain of different approaches to attaining specific health outcomes. These models also permit policymakers to apply epidemiology to decision making at a population level.

The aim of this thesis is to evaluate the use of public health models in policymaking, with regard to the appropriateness and the practicalities of using such models for simulating health interventions, and the application of the results of such modelling exercises to public health policymaking.

Through the adaptation and use of existing public health models for simulating the effects of risk factor interventions on CHD in the England & Wales population, this thesis will consider the limitations of the input data, the assumptions underlying the methodology of the model, and problems in translating interventions to the simulation environment.

The future role of public health models in policymaking will be discussed in terms of how and by whom they should be utilised, and the requirements for producing models that are able to address the policy agenda.

In this chapter I will first give an overview of modelling in general, with examples of various types of models used in different areas of health research, but I will concentrate on those that were designed for simulating coronary heart disease (CHD) interventions as an aid to public health policymaking. While the second part of the chapter describes in more detail seven public health policy models that I have identified.

PART I

1.2 Definitions

A model can be defined as a “*computerised mathematical description of some system of objects and activities*”, and modelling as “*the art of constructing and using such models as tools for analysing policy alternatives and evaluating operations*” (Lagergren 1995). While simulation can be viewed as “*the concept of modelling complicated systems by simpler ones*” (Ackerman 1994¹). I perceive modelling to be the use of simplified theoretical frameworks which allow the simulation of complex dynamic processes. It allows one to break down a process into its contributory sub-processes, and to investigate the interactions and importance of these sub-processes in relationship to the whole process and the other sub-processes.

The idea of models being a simplified version of reality has meant that there has been a widespread suspicion of mathematical modelling within the health and medical

communities, as simplification was considered to overlook too many key features of a real system (Ackerman 1994¹). However, in recent years there has been a growing acceptance of mathematical model in health (Royston 1999), particularly with the appearance of WHO's Global Burden of Disease model (Murray 1997¹).

Lagergren (Lagergren 1995) identifies three different objectives that can be achieved by using models:

- making prognoses regarding the future development of the system,
- evaluating decision alternatives by calculating outcomes of different choices,
- developing a deeper insight into the properties of the system and how it reacts to different stimuli as a basis for policy development.

Whether these objectives are achieved will depend on the purpose of the modelling exercise, although some objectives may be achieved through the modelling process even though they were not the aim of the exercise. In the course of this thesis I will explore whether and how public health models achieve these goals.

1.3 Types of Model

Non-communicable disease models have been developed in a number of areas for simulating interventions relating to screening (Habbema 1984), medical interventions (van Hout 1992), resource allocation (Taket 1992) and risk factor reduction (Gunning-Schepers 1992²). Many such models have concentrated on various forms of cancer (Habbema 1984, Michalski 1992, McPherson 1992 and Rusnak 1992) possibly due the availability of data relating to incidence from cancer registries. More recently new infectious disease models have been developed relating to HIV (Blower 1992), with models simulating transmission among injecting drug users (van Haastrecht 1994 and

van Ameijden 1996), distributed incubation and variable infectiousness (Iannelli 1992), and the cost-effectiveness of prevention targeting (Kahn 1996).

In terms of CHD health policy there are several models which concentrate on individual risk factors (Grover 1992), risk factors and cardiovascular treatment (Capewell 1999¹), secondary care such as blood pressure screening (Selmer 1990 and Norman 1991) and cholesterol lowering treatment (Glick 1992), familial aggregation of disease (Aalen 1991), priority rating systems (Vilnius 1990) and pathways of coronary care (Bensley 1995), risk estimation and counselling (Thorsen 1979), estimating GP workload (Randall 1992), and cardiological treatment (Budde 1997 and Capewell 1999²).

Relative risks, population attributable risks and multiple logistic equations are used as the basis of many of these types of model (Chang 1990, Chambless 1990 and Clayton 1993). These same methods have previously been used to relate data from sub-population studies to an individual's risk, as with the Framingham Equation (Anderson 1990), the Dundee Risk Score (Tunstall-Pedoe 1991) and the British Regional Heart Study Risk Score (Shaper 1987).

1.4 Policy Models

Individual risk equations are not adequate on their own to relate how the demographic characteristics and risk factor profile of a population will determine the outcome of interventions on it, since the age and sex distribution will dictate the number of people at risk of disease, and with the associated patterns of morbidity and mortality will influence the magnitude of the effect of interventions.

It has been proposed that the following characteristics are essential for models that simulate health policy options (Chigan 1992):

- a time period during which risk factors may develop, latent periods before risk factors affect morbidity and mortality, and lag times during which risk factor changes translate into mortality reduction,
- multi-factorial risk factor/disease relationships, where one risk factor can influence several diseases, and one disease may be influenced by several risk factors,
- a demographic basis by which population changes within the simulation period can be considered.

These are the key features by which I define a public health model. A multiple disease environment with multi-factorial risk factor/disease relationships are essential components, since interventions on a single risk factor can have an effect on several diseases, as with cigarette smoking. In addition premature deaths avoided due to an intervention will result in more individuals at risk of other diseases at older ages. A demographic component is also necessary if one is to model the effect of interventions on specific populations, as not only will the distribution of risk factors within the population affect the health gain achieved by interventions, but also the structure of the population and how it ages will influence the amount of health gain achieved over time. Since my work involved issues concerning the primary prevention of CHD, I chose to concentrate on models that conformed to Chigan's criteria and included CHD.

My review of the literature found quite a number of CHD models as discussed in section 1.3, but very few models conform to Chigan's criteria. This is partly because CHD is a complex multistage disease (Heller 1987) for which there are few registries (Marmot 1992), particularly in terms of morbidity measures such as incidence, recurrence and survival. Models which attempt to simulate risk factor interventions on CHD must to some extent rely on informed estimates of these measures due to the lack of data. As a result such models are difficult to validate (Kotva 1992), and this raises questions concerning the appropriateness of using unvalidated models.

I have identified seven policy models that incorporate CHD, these are Prevent (Gunning-Schepers 1989:1992¹:1992²:1994:1995, Barendregt 1990 and Wolfson 1992²), the Coronary Heart Disease Policy Model (Morgenstern 1992, Wolfson 1992², Goldman 1989:1991, Hatzianreou 1988, Tosteson 1990, Tsevat 1991, Weinstein 1985:1987), NIMPH/TAM (Bonneux 1992:1994, TAM Research Group 1992 and Niessen 1993), Prevent Plus (Barendregt and Bonneux, personal communications), the CRISPERS model (Zhuo 1991¹:1991²:1991³:1994 and Ackerman 1994¹:1994²:1994³:1994⁴), POHEM (Wolfson 1991:1992¹:1992²) and the Global Burden of Disease model (Murray 1997¹:1997²:1997³:1997⁴). These models have all been developed for populations other than England and Wales, and so it is important to evaluate their appropriateness, in terms of their usability, when applied to this population, and their potential use in assessing the effect of health interventions.

PART II

1.5 Review of CHD Policy Models

The seven CHD policy models I have identified are either cell-based or micro-simulation models.

1.5.1 Cell-based Models

Within a cell-based model the population is subdivided into cells, such as by age, sex, and risk factor exposure categories, and it is to these separate cells that specific probabilities of events are applied. Over a simulated period the events for all the cells are summed to produce outcomes for the whole population, such as disease specific mortality rates for each age group in the population.

These models use less computer memory and processing time than the micro-simulation models described below, and can therefore be run on less powerful computers. For example, the Prevent cell-based model originally ran on an IBM PC with 640KB of

RAM and a maths coprocessor running under MS DOS 2.0. In general cell-based models tend to be easier for a lay audience to use and understand than micro-simulation models.

However, the methodology of cell based models inherently imposes restraints on the complexity of the model, since increasing the number of data sets, risk factors, diseases, disease/risk factor relationships, age groups, or exposure categories will produce unmanageably large matrices of cells. This is a major disadvantage of this type of model. For instance, with Prevent, a risk factor with two exposure categories covering 5 age groups for both sexes and linked to one disease will produce 20 cells for the prevalence of the risk factor, and these are associated with 20 probabilities of disease mortality, which equals 40 cells in all. Doubling the number of age groups, exposure categories and disease associations it will produce 80 cells for the prevalence, each with two probabilities of disease mortality, which equals 240 cells in all.

1.5.2 Micro-simulation Models

By contrast, micro-simulation models depend upon a monte-carlo simulation, where each individual in a cohort is generated separately using a random process, and over the simulation period these individuals can be subjected to certain events; the probabilities of these events being drawn randomly from distributions. These models, unlike cell based models, therefore have the capacity to absorb all the required risk factors and interdependencies. The models require powerful computers with large capacity memories, since the life of each individual in the population must be generated and stored. Statistics Canada run the micro-simulation model POHEM on a dual Pentium II 266Mhz with 132Mb DRAM. A simulation of 100,000 individuals takes about half an hour, while a run of 4 million individuals would take 16 hours. So even though the speed and capacity of readily available computers are increasing; technical constraints may still hinder such models' use as a policy tool.

1.6 Prevent

Prevent is probably the most accessible of the models, due to its menu driven interface, to be reviewed. The model was developed by Professor Louise Gunning-Schepers, who is now based in Amsterdam, for her PhD in 1988.

The minimum system requirements for running the model are an IBM compatible personal computer, using MS DOS 2.0 or higher, with 512KB RAM, a hard disk and a graphics adapter, although it is recommended to have 640KB RAM and a maths coprocessor.

Prevent is a cell-based simulation model that can estimate the health benefits for a population of changes in risk factor prevalence due to trends and interventions, in terms of absolute changes in such parameters as disease-specific and total mortality. The underlying methodology allows for (Gunning-Schepers 1989):

- the possibility that one risk factor affects several diseases, and that one disease is affected by several risk factors,
- a time dimension to simulate the reduction in excess risk after cessation of exposure to the risk factor,
- the interaction between the effect of the intervention and the demographic evolution in the population.

After the user has specified the risk factor to be intervened upon the model first calculates the autonomous development, using trends. Then the user specifies change in risk factor prevalences after the intervention and the model calculates the development due to the intervention and the trends. Next the model calculates the autonomous development of all other risk factors that share diseases with the intervention risk factors. For instance cigarette smoking is a risk factor for CHD, cerebrovascular

accident, chronic obstructive lung disease and lung cancer. Finally the results of the calculations are applied to two populations - one with only the autonomous developments, and the other with both the autonomous developments and the intervention effects. The differences between the two populations are attributed to the intervention, with the output given in terms of total and disease specific mortality (Barendregt 1990).

The original version of the model includes the following risk factors and causes of death (Barendregt 1990):

Risk Factors	Causes of Death
Cigarette smoking	Coronary heart disease
Hypertension	Cerebrovascular accident
Cholesterol	Chronic obstructive lung disease
Obesity	Lung cancer
Alcohol	Cirrhosis of the liver
	Breast cancer
	Traffic accidents
	Accidental falls

Table 1.1 – Prevent risk factors and causes of death

The model has a number of restrictions to limit the size of the data sets used (Barendregt 1990), and consequently the computer memory required, these are:

PREVENT Restrictions
A maximum of 9 risk factors
A maximum of 9 diseases
A limit of 4 diseases to be influenced by one risk factor
A limit of 4 risk factors to influence one disease
A maximum of 6 risk factor age groups
A maximum of 5 exposure categories
A maximum simulation period of 50 years

Table 1.2 – Prevent restrictions

The programme has recently been updated for use with Windows NT, which has removed many of these restrictions, although a full working version is yet to be completed.

The main drawback to Prevent is that it only gives results of modelling in terms of mortality. No output information is available on morbidity, or the costs of treatment.

1.7 The Coronary Heart Disease Policy Model

The Coronary Heart Disease Policy Model (CHDP Model) is a state-transition model, where individuals move from a well state through a number of disease states before death. This cell-based model was developed in 1987 by Dr Milton Weinstein at Harvard. It allows the user to simulate the effects of intervention, both preventive, by risk factor modification, and therapeutic, by changing case fatality rates, on mortality, morbidity and cost for up to a 30 year period.

The CHDP Model is made up of three consecutive sub-models (Weinstein 1987):

- The Demographic-Epidemiologic Model (DE Model), which contains the disease free population of 30-84 year olds' stratified into cohorts by age, sex and risk factor levels. It uses a logistic risk function based on the Framingham equation to calculate the annual incidence rates of CHD events for each cohort.
- The Bridge Model simulates the initial 30 days after the incidence of the first CHD event, with numbers having been passed on from the DE Model. First it determines the type of CHD event by age range and sex, then applies probabilities of death during the first 30 days following the event by age, sex and type of event. The survivors then move into the next sub-model.
- The Disease History Model (DH Model) classifies the population with a previous CHD event into twelve CHD states, and by age and sex. In each simulation year patients in each strata are subjected to eight CHD event probabilities, which they may or may not experience, and each event and state have associated case fatality rates for CHD and non-CHD death, depending on disease history, age and sex. These case fatality rates are applied to the population to calculate those who survive to the next year of simulation and those who die.

The main problem with the CHDP Model is that the number of strata can get very large. The existing model uses 5400 strata in the DE Model and 1200 strata in the DH Model (Weinstein 1987). Adding one risk factor with two levels of exposure will double the number of strata used. Another problem is that the Bridge Model has a cardiac arrest pathway. This was initially included to highlight the need for paramedic services in the USA by demonstrating the effect of increased survival due to resuscitation en-route to hospital. These cardiac event have been included under fatal acute myocardial infarction in later incarnations of the model as NIMPH (TAM Research Group 1992) and POHEM (Wolfson 1992).

The model was produced in 1987, and therefore the only revascularisation procedure included was coronary artery bypass surgery. There is no percutaneous transluminal coronary angioplasty. More recently the model has been adapted for use with the Australian population (Mui 1999).

Although called a “policy model” the CHDP Model does not conform to my definition of a policy model since it does not simulate a multi-disease environment.

1.8 The Netherlands Integrated Model of Public Health

The Netherlands Integrated Model of Public Health (NIMPH), formerly known as TAM, was produced by Jan Barendregt, who programmed PREVENT, and Dr Luc Bonneux at Erasmus University in Rotterdam. It is a cell-based model that is used to simulate a multi-disease environment, where individuals are at risk from 32 disease groups, with each disease being part of a separate submodel, the CHD model being just one of them. The methodology allows the simulation of the following phenomena (TAM Research Group 1992):

- Co-morbidity – the concurrent prevalence of two or more diseases in one person,

- substitution of causes of death – where death is caused by more than one diseases, and so the age specific mortality rate of one disease will be affected by changes in the age specific mortality rate of another disease,
- population heterogeneity – differences in risk factor exposure by age group and sex,
- mortality selection – individuals exposed to risk factors have a higher than average probability of developing and dying from various associated diseases, and as they die over time the risk factor profile of the population changes and so mortality rate change,
- competing death risks – when two or more diseases have a risk factor in common.

At a first glance the NIMPH coronary heart disease sub-model seems very similar to Weinstein's model. It is made up of a number of further sub-models - a population model and a disease model, which includes a Bridge Model, as in Weinstein's model, a CHD model and a CHF (congestive heart failure) model. However, its methodology is different. The model is based on the principle of multi-state life tables, where life expectancy in various health states is used. NIMPH has no risk factors so does not use the Framingham equation, but calculates the proportional disease prevalences using disease specific mortality and incidence rates, and these are applied to a synthetic cohort (TAM Research Group 1992). The output figures are calculated as percentages and these are applied to the absolute numbers in the population model.

For each time step the disease sub-model computes the prevalence and the disease specific mortality rate from the incidence rate and the relative survival rate in terms of percentages, without calculating absolute numbers. Then the disease specific mortality rates from the sub-models are combined with the total mortality rate in order for the population model to calculate the number of people alive in the next time step.

As with Weinstein's model, people in the well population who experience their initial CHD event move into the Bridge Model for the first 30 days of illness. However, cardiac arrest is not classed as a separate event, but is included with, and classed as, a myocardial infarction. Percutaneous transluminal coronary angioplasty is modelled as well as coronary artery bypass grafts. Those that survive can then move into either the CHD model or the CHF model depending on their CHD events. Within the CHD model patients can experience further CHD events over time until they die, or they move into the CHF model. Patients in the CHF experience further CHD events until they die; they cannot move into the CHD model (TAM Research Group 1992).

The developers of the NIMPH model are currently working on separating the CHF model from the CHD model, and then creating an overall Cardiovascular Disease model which will incorporate the CHF, CHD and Stroke models as sub-models. Work is also in progress to add a risk factor module.

1.9 Prevent Plus

The Rotterdam team, who produced Prevent and have developed NIMPH, have produced a version of Prevent that includes morbidity and costs called Prevent Plus. Like its predecessor Prevent Plus is a cell-based model. It includes the following risk factors and diseases (Barendregt and Bonneux, personal communications):

Risk Factors	Causes of Death
Cigarette smoking	Coronary heart disease
Hypertension	Cerebrovascular accident
Cholesterol	Lung cancer

Table 1.3 – Prevent Plus risk factors and causes of death

And produces output on the following:

- Disease specific hospital days,
- Disease specific costs,
- Disease specific unhealthy person years,
- Aggregated hospital days,

- Aggregated costs,
- Aggregated unhealthy person years,
- Aggregated population hospital days,
- Aggregated population costs,
- Aggregated population unhealthy person years,
- Disease specific incidence (rates),
- Disease specific incidence (numbers),
- Disease specific incidence reduction (numbers),
- Disease specific prevalence (rates),
- Disease specific prevalence (numbers),
- Disease specific prevalence reduction (numbers).

The model initially used survival times and case fatality rates to produce some measure of morbidity, but now output from NIMPH on incidence rates and on incidence specific prevalence, which is the disease prevalence due to the incident rate, is used to calculate morbidity. The underlying methodology is based on a special type of multi-state life table called a proportional multi-state life table, which allows for at least one disease state as well as the normally used states of alive and dead (Barendregt and Bonneux, personal communications).

As with Prevent, the model was originally produced to run under DOS, but has been updated to run using Windows NT.

1.10 The Population Health Model

The Population Health Model (POHEM) has been developed by Dr Michael Wolfson at Statistics Canada in Ottawa. It uses the micro-simulation technique to model the dynamics of multiple risk factors and major diseases, one of which is CHD, under various demographic and health-related processes for a heterogeneous population (Wolfson 1992²). The model was originally written in APL, but has been converted to Visual C++ to make the code more accessible to other users. This process was

envisioned by Statistics Canada to have been relatively quick and simple, but has taken over four years to complete.

The model uses a monte-carlo process to generate random life tables, where, within each year, an individual is randomly simulated to either die, become ill, or stay well. The probabilities of changing states are randomly drawn from age specific uniform distributions. This process is repeated a considerable number of times to produce a large synthetic cohort (Wolfson 1992¹).

As well as the monte-carlo process POHEM uses a number of dynamic algorithms to simulate the following processes (Wolfson 1991):

- Environmental exposures, such as toxic substances or stressful work environment,
- Socio-economic status, such as income or marital status,
- Risk factors, such as high blood pressure or cigarette smoking,
- Diseases, such as CHD and lung cancer,
- Functional status, such as gross motor function or vision,
- Health care utilisation such hospitalisation,
- Summary health status, based on functional status.

Within the Disease process is the CHD model, which uses Weinstein's model transformed to be consistent with the POHEM architecture, and uses Canadian risk factor distributions and treatment protocols (Wolfson 1991). Since it avoids having to stratify the population by age, sex and risk factor levels, as with cell-based models, POHEM does not start off computationally too memory hungry, although it takes longer for a simulation run and requires more data storage space, due to its having to generate each individual of the cohort separately.

Overall the methodology of POHEM gives it great flexibility, with its ability to include external factors such as social status and environmental exposure, as well as the traditional risk factors. In addition, the model seems to produce more detailed

information on morbidity, in terms of functional and health status, and cost, in terms of health care utilisation.

1.11 The Chronic Disease Risk Intervention Simulation Program for Epidemiological Research Studies

The Chronic Disease Risk Intervention Simulation Program for Epidemiological Research Studies (CRISPERS) model was developed by Dr Park and Dr Zhuo at the University of Minneapolis for their Ph.D.'s, submitted in 1987 and 1991 respectively.

It is a stochastic compartmental model for simulating the effect of risk factor interventions on CHD morbidity and mortality for a micro-population (Zhou 1991¹). The model includes the risks factors cholesterol, diastolic blood and cigarette smoking as dichotomous variables, the distribution of which are taken from an actual population (Zhou 1991³). The risk factor distributions are used by a multivariate risk function, derived from the United States Railroad (USR) study population made up of men aged 40 to 59, to generate disease events (Zhou 1991¹). These events are:

- Incident myocardial infarction MI (fatal and non-fatal);
- Cardiac death;
- Death from other causes.

The CRISPER model uses a methodology of disease states, very similar to the CHDP Model, while the model generates individuals using a monte-carlo process as used by POHEM. At the start of a simulation an individual is generated as being in a “healthy” state, meaning that they having no history of MI. In each simulation time interval a healthy individual has the probability of experience one of the three events mentioned above, or remaining healthy depending on their risk factor distribution. If an individual survives the time interval without experiencing an event, then the individual will continue in the healthy state until the next time interval. If the individual experiences a cardiac death, a fatal MI, or death from other causes they leave the model. However, if

an individual experiences a non-fatal MI then he or she will move into a “previous MI” state, and in the next time interval they can experience no change, a death from other causes with CHD, a prevalent CHD death, or a recurrent non-fatal MI, depending on their risk factor distribution and the time since their initial MI. This process continues for each time interval until the individual dies, and then the process is begun again with a new healthy individual, and repeated until the micro-population has been created. The whole process is repeated using a risk factor distribution resulting from an intervention, and the two runs are compared to calculate the effect of the intervention on the micro-population (Zhou 1991¹).

As with the CHDP Model, the CRISPER does not conform to my definition of a policy model since it does not simulate a multi-disease environment, where several risk factors influence several diseases.

1.12 The Global Burden of Disease Model

The Global Burden of Disease Model was developed by Dr Murray and Dr Lopez at the request of the World Bank, and in collaboration with WHO, as part of the Global Burden of Disease (GBD) Study in 1992. The three primary goals of the GBD study were to provide information on international non-fatal health outcomes for debates on international health policy, to develop unbiased epidemiological assessment for major disorders, and to quantify the burden of disease with a measure that could also be used for cost-effective analysis (Murray 1997¹). Within the remit of these goals there were four specific objectives (Murray 1997¹):

- I. To develop internally consistent estimates of mortality for 107 causes of death by age, sex, and geographic region.
- II. To develop internally consistent estimates of incidence, prevalence, duration, and case-fatality for 483 disabling sequelae of the 107 causes.

- III. To estimate the fraction of mortality and disability attributable to ten major risk factors.
- IV. To develop various projection scenarios of mortality and disability estimates by cause, age, sex, and region.

The ten major risk factors included in the model were malnutrition, poor water, sanitation and hygiene, unsafe sex, alcohol, occupation, tobacco use, hypertension, physical inactivity, illicit use of drugs, and air pollution (Murray 1997³).

The regions, defined by the World Bank, that the model was applied to were (Murray 1997¹):

- High income Organisation for Economic Cooperation and Development (OECD) members;
- Former socialist economies of Europe;
- Latin America and the Caribbean;
- China;
- India;
- The middle eastern crescent;
- Other Asia and islands;
- Sub-Saharan Africa.

The model can calculate the attributable burden of disease for a specific risk factors, population and time, which is defined as “the difference between currently observed burden and the burden that would be observed if past levels of exposure had been equal to a specific reference distribution of exposure”, where the reference distribution of exposure is defined as the risk factor exposures with the lowest relative risk (Murray 1997³).

CHD is included in the model, and is modelled as being caused by tobacco use, hypertension and physical inactivity, and reduced by alcohol at all levels of consumption. The model uses attributable fractions, taken from reviews and meta-analyses, applied to the population of a region to calculate the burden of disease of these risk factors (Murray 1997³).

1.13 Applying Models to the England & Wales Population

Having reviewed the models I decided to proceed with the Prevent and POHEM models, since they conformed to my criteria for being classed as policy models, they included CHD as one of the diseases they could simulate, they could be adapted for use with the England & Wales population, and their developers were willing for others to develop their own country versions of the models.

In the chapters that follow I chronicle my use of Prevent and POHEM models. I describe how I have adapted these models for use with the England & Wales population, the problems I encountered, and how I have overcome or circumvented these problems. In addition I will discuss their use as policy tools, in terms of their ease of use, data needs and ability to model policy relevant interventions.

Chapter 2 - Policy Decisions in Public Health

2.1 Introduction

Public health models use simplified theoretical frameworks which allow the simulation of complex dynamic processes, and the construction of these frameworks are dependent on theoretical models that link biological, environmental, social and economic factors to health. It is necessary to understand these theoretical models, and how their factors for health relate to the health policy agenda, in order to build public health models that can be used as a tool for policymaking.

This chapter begins with definitions of health, public health and health policy. Then continues by outlining the evolution of public health models with the shift from the Old Public Health to the New Public Health. The chapter then moves on to a discussion of the link between research and policy making, and the problems of translating research evidence into policy with reference to the Rational, the Realistic and the Incremental models of research. I conclude by discussing the role of mathematical modelling as an aid to policymaking.

2.1.1 The Concepts of Health, Public Health and Health Policy

Over time new definitions and concepts have been established with regard to health, public health and health policy (Berridge 2000). In discussing these concepts one needs to first define what is the current meaning of the terms. With regard to health WHO defines it as:

- *“a resource for everyday life, not the objective for living ... a positive concept emphasising social and personal resources, as well as physical capacities” - Ottawa Charter (WHO 1986);*

- “a resource which gives people the ability to manage and even to change their surroundings” - Achieving Health For All (WHO 1979).

Within these definitions there is a sense of health being the absence of disease and disability, as well as a resource which gives individuals the ability to interact with their surroundings, both in the social and the physical contexts.

In addition, WHO defines the “Prerequisites for Health” (WHO 1986), which are the fundamental conditions and resources for health. These are peace, shelter, education, food, income, a stable eco-system, sustainable resources, social justice, and equity. This fits with the definitions of health as being concerned with the individual and their environment.

Public health grew out of 19th century environmentalism which was concerned with health hazards in the physical environment. Following on from the work in the 1840s of Edwin Chadwick, which, at a time of epidemic diseases, highlighted the link between dirt and disease, and its association with overcrowding and sanitation; public health has now evolved to include the socio-economic environment (Berridge 2000). The Acheson Report (Department of Health 1988) defined public health as “*the science and art of preventing disease, prolonging life and promoting health through organised efforts of society*”, while Last defines it as “*the combination of science, practical skills, and beliefs that is directed to the maintenance and improvement of the health of all people ... through collective or social action*” (Last 1987).

Together these definitions regard public health as a phenomenon that can be influenced by collective action, and that has significance for the population as a whole, or for sub-groups within it, be they by age groups, ethnicity or socio-economic status (RIVM 1994).

Health policy can be defined as the action of government and other players which are aimed at maintaining and improving the population's state of health. It can be seen as having two goals (HMSO 1992):

- adding years to life - an increase in life expectancy and reduction in premature death,
- adding life to years – increasing years lived free from ill-health, reducing or minimising the adverse effects of illness and disability, promoting healthy lifestyles, physical and social environments and, overall, improving quality of life.

2.2 Public Health Models

There has been a change in the emphasis of health policy, driven by a shift from the Old Public Health model to the New Public Health model. The Old Public Health was mainly concerned with the consequences of unhealthy settlements, and in that context with the safety of food, air and water. In terms of diseases it was largely concerned with infectious, toxic and traumatic causes of death, which were predominant among young people and were associated with poverty. In contrast, the New Public Health emerged to meet a whole new set of diseases associated with longevity and over-population, with industrialisation and industrial decline, with inequalities in health in affluent societies, with environmental damage, and with ecological imbalance. This change has been influenced by the belief that many of the underlying factors for these diseases can be amenable to prevention through social, environmental or behavioural change (Lancet 1991).

The shift reflects how the perceived relationship between health, health care and disease has changed over time. These changes have been outlined in terms of a number of frameworks. The traditional view of the health, health care and disease relationship was that disease led to a need for health care, and required access to health care. The role of health care was seen as trying to cure existing disease, or care for the consequences of

disease, and was not concerned with the factors causing disease. Within this framework new or more disease leads to more health care being required, see Figure 2.1.

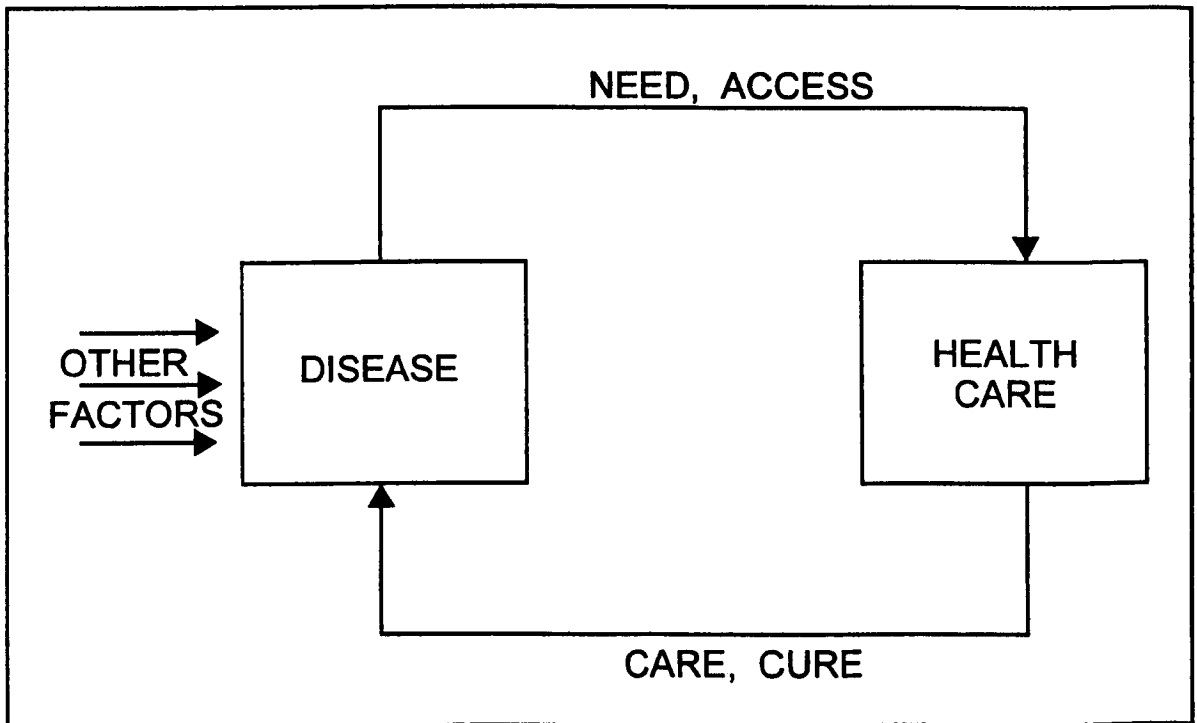

Figure 2.1 - Health care activities dominate issues of health policy (Evans 1990)

The 1970s and 1980s saw a move to investigate the area labelled “Other Factors” as health care costs increased, especially since a number of studies indicated the considerable scope for improving the efficacy, effectiveness, cost-effectiveness and appropriateness of health care utilisation, see Figure 2.2. By 1974, in Canada, the increasing costs of health care led the Minister of National Health and Welfare to producing a document entitled “*A New Perspective on the Health of Canadians*” (Canada 1974), known as the Lalonde Report. It called for a shift away from focusing on health care as the only determinant of health, and proposed consideration of the areas of lifestyle, environment and human biology. The Report identified the paradox that although most of the burden of ill health was a result of lifestyle, environment and human biology; most of the expenditure on health went into health care. And so advocated that improvements in the environment and in lifestyle would be the most effective means of reducing mortality and morbidity. Essentially, the Lalonde Report signalled the shift in emphasis from the treatment of illness to the prevention of illness

or, as Lalonde later remarked “*more positively, to the promotion of health*” (Lalonde 1977).

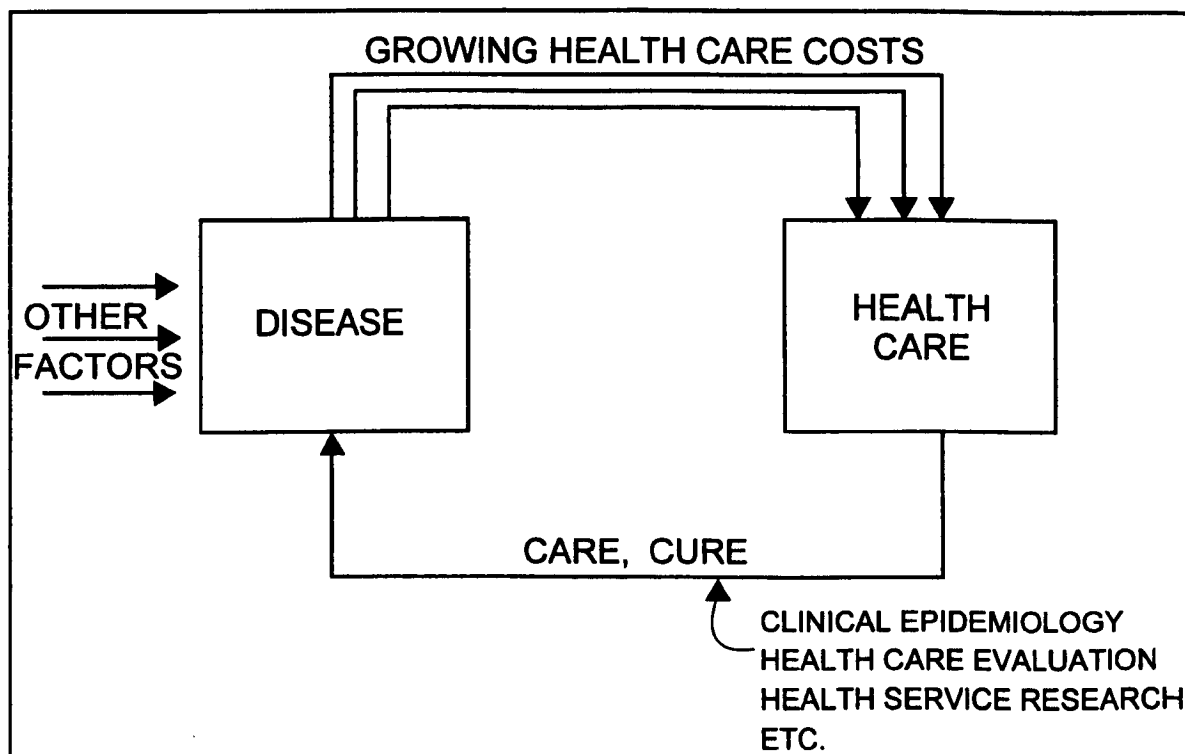

Figure 2.2 - Health policy of the 1970s and 1980s (Evans 1990)

The Report contributed to a focus on things individuals could do something about, especially in terms of individual risk factors for specific diseases. Interventions then began to be aimed at the individual. Underlying this policy development was the implicit model that individuals choose unhealthy lifestyles due to ignorance, and that once they are provided with the appropriate information they would change their lifestyles, and so improve their health status. This ignores the possibility that individuals may be informed and still choose unhealthy behaviour due to conditioning, personal enjoyment or their social environment. However, this philosophy of individual responsibility for health has made the framework politically attractive to conservative governments, since more individual responsibility to lead a healthier lifestyle is conceived as leading to less demands on health services and to state intervention, and so is seen to be a means of saving money for governments.

Since 1974 a considerable amount of research evidence has amassed which does not fit into the Lalonde framework. Evans and Stoddart (Evans 1990) identified new areas

which include the positive correlation between health and wealth, with the gradient in the relationship of socio-economic status to health which exists across countries, across different diseases and other measures of health, and across time. Also, they noted that access to health care has not narrowed the inequalities in the distribution of health across socio-economic groups. They also identified a strong positive correlation between lack of social support and poor health, the importance of self-esteem, the ability to exert control over life and coping skills, and the potentially critical role played by childhood experiences. In addition, the emerging knowledge about genetic predisposition to disease, and the importance of interactions between the genetic endowment and the environment, both physical and social, were recognised by Evans and Stoddart. As well as considering the preliminary work on biologic pathways linking the mind, the nervous system and the immune system.

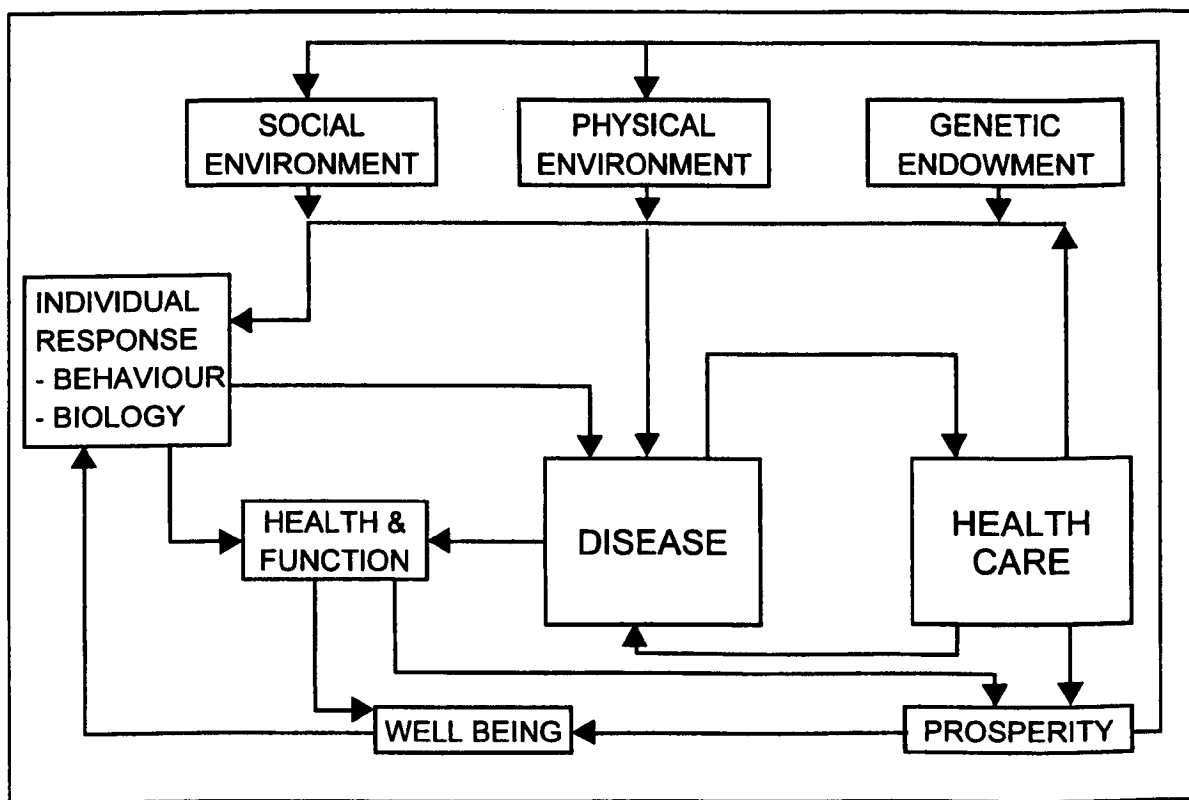

Figure 2.3 - Health policy after the Lalonde Report (Evans 1990)

In response to these shortcomings Evans and Stoddart (Evans 1990) suggested a model (Figure 2.3) which encompasses these issues, with the key addition of the “Individual Response” box which includes behaviour as well as biological responses to the individuals environment, and includes some factors or processes that were previously in

the lifestyle and human biology fields. In addition genetic endowment has been added, which includes the concept of predisposition to disease or ill health within certain physical or social environments. Finally, a Prosperity box has been added to allow for the effects of changes in productivity, income and wealth on living standards, and in turn on social environment. This framework has been encompassed by the Social Ecological Theory (Stokols 1996), the main concepts of which are (Coombes 2000¹):

- Environmental settings have multiple physical, social, and cultural dimensions that can influence a variety of health outcomes.
- The health promotive capacity of an environment is the cumulative impact of multiple environmental conditions.
- Human health is not only influenced by environmental factors, but also personal attributes such as genetic heritage, psychological disposition, and behavioural patterns.

The last framework, along with this theory, attempts to conceptualise the current views on the relationship between health, health care and disease.

2.3 Issues In Current Health Policy

Since the Black Report (DHHS 1980) on inequalities in health it has been becoming increasingly clear that social deprivation provides a major determinant of poor health status (Birt 1996). While in the UK and US, although there has been an overall decline in death rates, socio-economic differences in death rates have been increasing (Marmot 1997).

Social class has been demonstrated to be robust predictor of health outcomes be it measured by education, income, or occupation (Marmot 1989), with occupational social class being strongly associated with overall and non-cardiovascular mortality, and

education being more strongly associated with cardiovascular death (Davey-Smith 1998¹).

Differing levels of the traditional risk factors by social class only account for a small proportion of the differences in health observed (Marmot 1989). It has been suggested that these differences may be due to in utero and early life experiences (Barker 1986), or psychosocial factors, such as low control of in the work environment and lack of social support (Marmot 1989 and Davey-Smith 1998¹).

In recent years the idea of social capital, defined as *“the features of social organisation, such as civic participation, norms of reciprocity, and trust in others, that facilitate co-operation for mutual benefit”* (Putnam 1995), has crept onto the policy agenda, being mentioned in the Labour government’s *“Our Healthier Nation”* white paper (DoH 1999). It has been argued that even though much of the rhetoric of public health pays lip service to the value of community focus and empowerment, there is less evidence of this commitment in service provision (Lomas 1998), and that there is no good theoretical account of how to build social capital (Kawachi 1997).

Clearly with these new areas of interest there is need for aetiological research to explain biological pathways (Marmot 1989), as well as for epidemiological research to explain their effects on risk (Ben-Shlomo 1996 and Davey-Smith 1998¹), and their implications for policy (Marmot 1997).

2.4 The Link Between Research Evidence And Policy Making

It may seem that once a framework of how various factors influence health and disease has been identified; the research evidence would change health policy with the goal of improving health. However the process is not so straight forward. There are two perceptions of the way that research influences policy (Walt 1995); the idealistic, under which the link between research and policy is seen as a rational process, and the

realistic, which assumes that research filters into policy through a process of enlightenment.

2.4.1 The Rational Model of Research and Policy Development

The rational or synoptic model is based on the concept that development of policy is a linear process, which is either knowledge driven, or problem driven. If the model is knowledge driven, the concept is that basic research will lead on to applied research, development of new policy and finally policy application, while if the model is problem driven, the concept is that the identification of a problem will lead to a search for solutions, which in turn will lead to policy action.

Walt (Walt 1994) outlines the rational policy making process using the following steps:

1. The policymaker is faced with a particular problem which can be separated from other problems, or compared with other problems.
2. The goals, values or objectives that guide policymakers are clarified and ranked according to their importance.
3. The various alternatives for dealing with problems are considered.
4. The consequences (cost and benefits) following from the selection of each alternative are investigated.
5. Each alternative, and its consequences, are compared with other alternatives.
6. The policymaker chooses the alternative (and its consequence) that maximises the attainment of their goals, values or objectives.

Behind this theory are a number of assumptions that presume researchers follow a rational process in asking the right research question, planning and conducting the research, and then disseminating their findings, which are objective, quantifiable and present solutions. Moreover, it is assumed the policymaker reads the research results, understands the findings and implications of the research, and then acts on the results (Walt 1994).

However, in reality, a rational policy development rarely happens; policymakers are constrained from behaving rationally in many ways. First of all, policymakers are seldom faced with one clearly defined problem, usually they first have to identify and define the problem. Even once a problem has been identified it is often difficult to identify one or more specific causes of the problem since public health problems are often extremely complex. In some cases it is difficult to even define the problem before it can be addressed.

If the problem and its causes are identified, policymakers are still faced with the task of clarifying goals and objectives when tackling a problem, and of converting those goals into operational policies that can be implemented. One major difficulty they face is that predicting the cost and benefits of alternative strategies is a complex task, especially when health promotion strategies are intended to have long term effects, for example over the lifetime of young children.

Policymakers are seldom objective in their decision making. They are driven by their own priorities, and influenced by other bodies or factors, as in the UK with the Conservative government raising the recommended weekly alcohol guidelines, against the recommendations of the medical profession (Marmot 1995 and Report 1996) possibly due to the influence of the brewing industry. Present policies are often largely determined by past policies, since it is easier to implement adaptations of existing policies than completely new policies.

2.5 Problems in the Relationship Between Research and Policy

Research findings are not the property of research scientists, the funders, or the respondents in the research, but are part of a shared body of knowledge (Lewandowski-Hundt 2000). Ideally this body of knowledge informs health policy, but there are a number of barriers that prevent the link between research and policy being a simple, linear and logical process.

One of the most important influences is political factors. If governments are ideologically committed to a policy then research findings may only be of secondary interest, especially if the findings conflict with the policy impetus or its ideological basis. This was the case in the UK in the 1980's when the Conservative government's, under the leadership of Margaret Thatcher, introduced the internal market in health, which fitted with its ethos of improving services through competition, but was not evaluated in any way prior to its introduction. Policymakers may have different priorities from researchers and therefore regard their findings as irrelevant, or it may be that policymakers undervalue, or have unrealistic expectations of, the benefits of research to policymaking.

Barriers may also exist due to conceptual confusion. This is particularly the case in public health research which often does not provide unambiguous results. This lack of scientific certainty can lead to distortion and a lack of clarity in policy. In particular, in areas where research findings disagree policymakers may be reluctant to make firm decisions (Walt 1994).

The ways in which different risks are perceived, both at the individual and at the societal level, with an imbalance between actual and perceived risk may also impede the influence of research on health policy. An example of this is the reaction to the uncertainty about the risk of contracting CJD from British beef. This resulted in a European trade ban and falls in consumption (McKee 1997), but no such reaction is seen to the continued use of tobacco, with its known risks. The media often skew risk

information, as illustrated by a study of US network news (Greenberg 1992), which over a two year period monitored almost 500 stories on air crashes and only 57 about tobacco, when 250 Americans were killed in air crashes and about 800,000 died from smoking related illnesses. The media increases conceptual confusion because scientific disagreement makes a more interesting story than scientific consensus.

Since policymakers must often make decisions within a short time scale, research which takes a long time to produce results, as in the case of the effects of smoking interventions on CHD morbidity and mortality, is less attractive to them than research that produces results in the short term.

Communicability of research findings to policymakers is also important, with both the research and policy communities accepting that research communications, whether they are reports to funders or journal papers, are often esoteric, opaque and unclear. Findings are sometimes presented in a form which makes them inaccessible to non-experts, and so they do not pass outside tight academic circles. This is taken to the extreme where researchers feel that their work should only be written for fellow academics, and should not provide policy recommendations, leaving it to others to possibly extrapolate the findings into the policy domain. Other researchers feel that they have a public duty to disseminate their findings widely, channelling their results through the mass media, although the value of this dissemination will be heavily dependent on the accuracy of the reporting (Walt 1994).

2.5.1 The Realistic Model of Research

The barriers to policy implementation which have been discussed above are recognised in the realistic model of research. This model is based on the belief that to seek a direct link between research and policy is to misunderstand the nature of the policy environment, and that the focus of science on increasing knowledge and solving problems do not fit easily with the reality of policymaking (Walt 1994). New

information, ideas and knowledge do diffuse through the policy environment, and so become part of policymakers' thinking, but not in a clearly defined linear way.

In looking at the extent to which research influences policy one needs to take a longer and wider view, rather than searching for direct links between individual research projects and policy options; one needs to consider the accumulation of research evidence which leads to a gradual change in the knowledge and action of policymakers (Walt 1995).

2.5.2 The Incremental Model

The incremental model can be seen as the antithesis to the idealist model, and is essentially a hybrid of the realistic model. Walt (Walt 1994) identifies the key points of this model as:

1. The selection of goals and objectives, and the means of implementation are closely allied.
2. Policymakers look at a small number of alternatives for dealing with a problem, and they tend to chose options that differ only marginally from existing policies.
3. For each alternative only the most important consequences are considered.
4. There is no optimal policy solution.

Incremental policy making is essentially remedial, and focuses on small changes to existing policy rather than implementing major new policies. Policymakers must accept that few problems are ever fully solved, and that the process of implementing policy is an iterative one.

2.6 The Role of Mathematical Modelling as an Aid to Policy Making

The need to produce policies to tackle complex, chronic diseases such as CHD has meant that decisions have been made with incomplete or conflicting evidence (Levine 1987). Mathematical modelling may be a useful tool for investigating the effect of public health interventions, allowing one to consider varying levels of effectiveness and efficacy. Modelling can show how the quantification of the health benefits of alternative risk factor interventions can help in health policy (Gunning-Schepers 1989). For instance, the use of modelling to make estimates of the effect of prevalence changes are not only important in assessing the impact of preventive interventions, but also to estimate the health needs on which to base decisions about the levels of health services required. In addition, models may possibly be used as a tool to investigate different assumptions in areas where knowledge is limited, such as the effects of social class and early life influences on health, which are increasingly becoming important issues in health policy.

However, modelling will not dictate policy, but will only quantify one step in the policymaking process. As outlined, barriers other than the lack of evidence may hamper policymaking. In the following chapters I describe my investigations into whether mathematical models can be used by policymakers as policy tools, and what factors will influence their use.

Chapter 3 – Health Policy in England Since 1995

3.1 Introduction

In 1978 the International Conference on Primary Health Care, meeting in Alma-Ata, expressed “*the need for urgent action by all governments, all health and development workers, and the world community to protect and promote the health of all the people of the world*” in its ten point declaration (WHO 1978). Then in 1981 the WHO issued its *Health for All by the Year 2000* document (WHO 1981), the objectives of which were “*the attainment by all people of the highest possible level of health*” and “*that as a minimum all people in all countries should have at least such a level of health that they are capable of working productively and of participating actively in the social life of the community in which they live*” (WHO 1981).

This was followed in 1985 by *Targets for Health for All 2000* (WHO 1985), in which the WHO defined 38 targets for all regions of the world, including Europe, with specific figures for reductions in infant mortality, maternal mortality, mortality from diseases of the circulatory system, cancer mortality, and deaths from accidents. These targets were then updated in 1991 (WHO 1991), since the original targets included goals to be achieved by 1990 which needed to be reassessed.

Although the UK Conservative government of the time had endorsed the Alma Ata declaration on primary health care and *Health for All by the Year 2000*, since 1979 it had not acted on the issues raised and was seen to be resistant to setting health targets (Catford 1991 and Ashton 1991), but this changed in 1992 with its introduction of health targets.

This chapter describes the health policies for England that were in place, or have been implemented since 1995, coinciding with the time period for my work on public models detailed in thesis. In particular I will concentrate on the policies and the use of targets directed towards the reduction of CHD, and with this view I will discuss their implications to public health modelling.

3.2 The Health of The Nation Targets

Throughout Europe there has been a rise in demand for health related interventions, which can mean rising health care expenditure. In a world of limited resources this means that the most cost effective health strategies need to be identified.

Followed the lead set by the WHO with its *Health for All by the Year 2000* targets, and in an attempt to address the problem of the rise in demands on the health care system in England & Wales, the Government published its “*The Health of The Nation*” White Paper in 1992 (HMSO 1992), which set out targets for the reduction in the death rates for coronary heart disease, stroke, cancers, suicide and accidents, for the reduction in the incidence of sexually transmitted diseases and for reductions in the prevalence of cigarette smoking, alcohol consumption and obesity.

In England CHD accounted for about 26% of deaths in 1991 (HMSO 1992), and so was identified as an important area for the Government's White Paper. The White Paper introduced targets for the reduction in the death rates for coronary heart disease:

- To reduce annual death rates for both CHD and stroke in people under 65 by at least 40% by the year 2000 (from 58 per 100,000 population in 1990 to no more than 35 per 100,000 for CHD).
- To reduce the annual death rate for CHD in people aged 65 to 74 by at least 30% by the year 2000 (from 899 per 100,000 population to no more than 629 per 100,000).
- To reduce the prevalence of cigarette smoking in men and women aged 16 or over to no more than 20% by the year 2000 (a reduction of at least 35% in men and 29% in women, from a prevalence in 1990 of 31% and 28% respectively).
- To reduce the average percentage of food energy derived by the population from saturated fatty acids by at least 35% by 2005 (from 17% in 1990 to no more than 11%).

- To reduce the average percentage of food energy derived by the population from total fat by at least 12% by 2005 (from about 40% in 1990 to no more than 35%).
- To reduce the percentage of men and women aged 16-64 who are obese by at least 25% for men and at least 33% for women by 2005 (from 8% for men and 12% for women in 1986/87 to no more than 6% and 8% respectively).
- To reduce the mean systolic blood pressure in the adult population by at least 5 mm Hg by 2005.
- To reduce the proportion of men drinking more than 21 units of alcohol per week from 28% in 1990 to 18% by 2005, and the proportion of women drinking more than 14 units of alcohol per week from 11% in 1990 to 7% by 2005.

The introduction of these new health targets were widely perceived as a welcome change in health policy for the Government (Ashton 1991, Gabbay 1992 and Mooney 1991). The recognition that intersectoral policy and collaboration is needed to achieve these targets was particularly welcomed (Ashton 1991). However, the document was heavily criticised for its lack of discussion on poverty and inequalities (Ashton 1991, Gabbay 1992, Dean 1992 and Davey-Smith 1994). Underlying this omission was the Government's belief that improvements in health would result from telling individuals to live more healthily, which ignored the WHO principle of encouraging people to participate in decisions (Gabbay 1992). Others argued that unhealthy behaviour did not occur in a social vacuum (Davey-Smith 1994), and that there was a need for social and economic policies changes that would allow individuals to choose the healthy option (Gabbay 1992), without which health inequalities may increase (Davey-Smith 1994). As Klepp et al stated "*only exceptional, highly motivated individuals will be able to confront and cope with the social norms, marketing practices, and economic realities which combine to reinforce their current health-compromising behaviors*" (Klepp 1985).

The Government's desire to improve health was thought to be contradictory to its policies on taxation and benefits, which were resulting in increased inequalities in

Britain, with the proportion of those living in poverty being twice as high as it was 30 years previously. Twenty percent of £27 billion in tax savings achieved in the first decade of the Conservative government went to the 200,000 highest paid members of the population, while only 2% went to the three million lowest paid (Dean 1992). In addition, it was felt that the Conservative governments' links to the tobacco industry were at odds with its call to fight lung cancer and heart disease, made apparent by its reluctance to ban tobacco advertising (Health Education Authority 1991, Dean 1992 and Gabbay 1992).

Review of the Government's 27 targets in 1996 (Langlands 1996) showed that the progress of the 23 targets were moving in the right direction, although a later study (Troop 1997) showed that only 9 would achieve their actual target values. While it has been commented that some of the targets seem to have been calculated based on the current trends (Mooney 1992). The trends for the prevalence of drinking amongst men and women had showed no change, while the prevalence of obesity in the whole population and of smoking amongst 11 to 15 year olds has risen. The Government's lack of initiatives to address inequalities remained a key concern for researchers.

3.3 Saving Lives: Our Healthier Nation

In May 1997 the Labour party won the General Election and replaced the Conservative government. In aiming to show continuity with the previous Government's health promotion strategy (Maxwell 1998) they issued the "*Saving Lives: Our Healthier Nation*" White Paper in 1999 (DoH 1999), building on the targets of *The Health of The Nation*. The main differences between *Our Healthier Nation* and *The Health of The Nation* were in the recognition in *Our Healthier Nation* that health depends on social and economic conditions, as well as the environment, lifestyle, access to services and fixed risk factors, and in its awareness of the role of inequalities in health (Gabbay 1998 and Horton 1998).

The aims of *Our Healthier Nation* were:

- To improve the health of the population as a whole by increasing the length of people's lives and the number of years people spend free from illness.
- To improve the health of the worst off in society and to narrow the health gap.

Four priority areas were identified and targets to be achieved by 2010 were set:

1. Heart disease and stroke – target to reduce the death rate from coronary heart disease and stroke and related diseases in people under 75 by at least two fifths - saving 200,000 lives.
2. Accidents – target to reduce the death rate from accidents by at least a fifth and to reduce the rate of serious injury from accidents by at least a tenth - saving 12,000 lives.
3. Cancer – target to reduce the death rate from cancer in people under 75 by at least a fifth - saving 100,000 lives.
4. Mental health – target to reduce the death rate from suicide and undetermined injury by at least a fifth - saving 4,000 lives.

These priority areas are similar to those of *The Health of the Nation*, apart from the exclusion of HIV/AIDS and sexual health as a priority area, which is now encompassed in a wider action on public health along with drugs, alcohol, food safety, water fluoridation, communicable disease, genetics and the health for black and minority ethnic groups.

Within the section covering heart disease and stroke there are action points for reducing risk and staying healthy:

- major changes in diet, particularly among the worst off, with increased consumption of such foods as fruit, vegetables, and oily fish;
- large reductions in tobacco smoking particularly among young people, women and people in disadvantaged communities;
- people keeping much more physically active - by walking briskly or cycling, for example - on a regular basis;
- people controlling their body weight so as to keep to the right level for their physique;
- avoiding drinking alcohol to excess.

These less defined action points replaced the more explicit targets of *The Health of The Nation* which gave specific targets for reductions in the prevalence of cigarette smoking, the average percentage of food energy from saturated fatty acids, the average percentage of food energy derived from total fat, the prevalence of obesity, the mean systolic blood pressure, and the prevalence of heavy drinking. While physical activity was added to the CHD health agenda.

The smaller number of national targets were presented as offering greater flexibility to focus on particular health problems and on health inequalities. While the broader nature of these targets were shown as offering additional challenges and opportunities compared to the strategies of *The Health of the Nation*. However, the Government has been criticised for the document's lack of objectives concerned with the reduction of inequalities (Maxwell 1998). There was little point in accepting that socio-economic factors influence health if targets were not set for their improvement (Gabbay 1998). Although a budget of £96 million had been allocated to public health development; none had been allocated to reducing health inequalities (Gordon 1999).

The White Paper was also criticised for only using mortality measures in its assessment of the disease related targets (Gabbay 1998), its emphasis of disease based health care over wider public health concerns (Fulop 1999), and its lacks of plans for the implementation of its policies (Maxwell 1998), with its rather vague action points that have no targets for the changes recommended.

3.4 Independent Inquiry into Inequalities in Health Report

In 1997, the then Minister for Public Health, Tessa Jowell commissioned an independent review of inequalities in health under the chairmanship of Sir Donald Acheson. The aims of the Inquiry were to review the evidence on inequalities in health in England, and to identify areas for policy development likely to reduce inequalities. The Inquiry lasted 12 months and its findings were published in 1998 as *the Independent Inquiry into Inequalities in Health Report* (Acheson 1998).

The Report made 39 recommendations covering 12 areas for future policy development. These areas were:

- poverty, income, tax and benefits;
- education;
- employment;
- housing and environment;
- mobility, transport and pollution;
- nutrition and the Common Agricultural Policy;
- mothers, children and families;
- young people and adults of working age;
- older people;
- ethnicity;
- gender;
- the National Health Service.

Overall the Inquiry identified three areas of action as being crucial to reducing inequalities in health, these were:

1. all policies likely to have an impact on health should be evaluated in terms of their impact on health inequalities;
2. a high priority should be given to the health of families with children;
3. further steps should be taken to reduce income inequalities and improve the living standards of poor households.

The Report was widely welcomed as a successor to the Black Report (DHHS 1980) on inequalities (Davey-Smith 1998², Black 1999 and Williams 1999), particularly with regard to its identification of areas other than the NHS as having a major role in reducing inequalities in health (Williams 1999). However, it was criticised for its recommendations not having been costed (Davey-Smith 1998², Black 1999 and Birch 1999), or there being no mention of the resource implications of the recommendations (Williams 1999). It was also felt that the recommendations were not presented in a hierarchy of priority (Williams 1999), with the under-emphasis of the premise that inequalities in health are largely dictated by inequalities in wealth (Davey-Smith 1998²). In addition, it was thought that the recommendations were too vague, and did not specify how their aims would be achieved (Davey-Smith 1998² and Black 1999), although this was contested by the Chairman of the Inquiry and others (Acheson 1998 and Ashton 1999).

It was seen as being unfortunate that the Inquiry was instructed by the Government not to produce targets, and that targets are need if general recommendations are to be turned into exact operational plans (Black 1999).

3.5 The Effect of Targets on the Policy Agenda

The setting and tracking of health targets help to form a national health agenda and identify explicit health policies (Catford 1991), and their popularity has been

demonstrated by the WHO and UK Governments. However, the use of targets has been criticised in that they result in priority being given to outcomes that can be easily measured, such as rates of illness and death, and not quality of life (Adams 1991 and Elkan 1998). This is illustrated by the targets of both *Our Healthier Nation* and *The Health of The Nation* which concentrate on reductions in death from coronary heart disease, stroke, cancers, suicide and accidents. The only target addressing incidence rates in *The Health of The Nation* solely relates to sexually transmitted diseases. This is arguably because these data are already collected for the UK by the Public Health Laboratory Service Aids Centre and the Scottish Centre For Infection & Environmental Health, and so are possibly easier to monitor.

Targets that are perceived to be unrealistic may be dismissed as unattainable (Elkan 1998). Targets may also lead to “initiative fatigue” when targets are not achieved as those responsible for them find it difficult to achieve the other demands of running services. This was experienced with *The Health of The Nation* targets (Gabbay 1998). In addition, targets such as those in *The Health of The Nation* may skew local priorities and do not lead to equity between different groups in society (Elkan 1998), when variations in health by geographical region, age, sex, socio-economic, or ethnic group are not considered (Davey-Smith 1994).

Some of these criticisms have been addressed by the *Our Healthier Nation* document, with the use of fewer national targets, and by allowing for local flexibility in the setting of local priorities and local targets. However, there are still the problems of targets being unattainable and being measured solely in terms of mortality (Gabbay 1998).

3.6 The Implication of Targets for Modelling

Current health care demands require immediate policy decisions to be implemented (WHO 1982), but targets are difficult to evaluate in terms of how they will be achieved and how much health gain they will deliver, a problem common to the assessment of health promotion policy (Coombes 2000²). There is a need for the effectiveness of different intervention strategies, or new therapies taken from experimental or observational methods, such as randomised control trials, or cohort studies, to be

extrapolated to a given population. Using public health models to simulate health interventions aimed at achieving such targets has been seen as a partial solution to this problem (Gunning-Schepers 1999).

My work on modelling began during the period of *The Health of The Nation*. It was felt that public health models could be useful in assessing the relative health gain of alternative routes to the attainment of strategic goals, such as *The Health of The Nation* targets, and would be helpful for applying epidemiology to decision making at a population level. This thesis investigates the extent to which modelling could be used to assess health gain and the extent to which such modelling might be used for decision making.

Chapter 4 - Data Sources

4.1 Introduction

One of the perceived strengths of public health computer models is that they use available data on risk factor prevalence and population demographics, rather than requiring new data to be collected specifically for the model (Gunning-Shepers 1989). However, different countries may collect different data in their health surveys and censuses, which means that a model developed in one country, which uses data collected in that country, may not be readily transferable to another country, since these same data have not been collected for the second country. Consequently, data from other sources, such as from a regional level, or from another country with similar population characteristics, are used. This will have repercussions on the validity of the model if the data are not representative of the population to be modelled. Mathematical modelling is very data-demanding, and the validity of a model will depend heavily on the data used by it. In this chapter I will outline the data sources I have used for input to the Prevent and POHEM models, the uses of which are described in the following chapters.

4.2 Census Data

Census data (OPCS 1995¹) contain a range of information for Great Britain on population and households, including demographic characteristics, students and schoolchildren, communal establishments, persons with long-term illness, ethnic groups, economic activity, migrants, household composition, tenure, amenities, availability of cars, and type of household space.

The last Census took place on 21st April 1991, and sampled 97.9 per cent of the population of Great Britain. In particular there was a one percent short fall amongst those aged between 19 and 31, predominantly amongst men, with this discrepancy peaking at 6 percent at age 27. This is thought to be due to council tax avoidance (Charlton 1997).

4.3 National Population Projections

The purpose of the national population projection is to provide future estimates of the United Kingdom population, and these have been produced in their current form since 1949. The projections use population data on current size and age structure taken from the most recent Census, then estimate the changes in population size due to births, deaths and net migration. Consequently errors in population estimates will mainly be a result of errors in the projections of each of these three components. These errors have been significant in the past (Shaw 1994).

I have used the national population projection for England & Wales in 1993 (OPCS 1995²) as the base year population for the models discussed in this thesis, as well as using the data as the denominator in calculating rates. Hopefully, as the projected population has been calculated only two years after the 1991 Census, errors in the estimation of this population will not be significant, as uncertainty is more likely to increase with time since the last Census.

4.4 Mortality Statistics

Mortality Statistics (OPCS 1995³) presents mortality data by cause of death for England & Wales. These data have been produced annually since 1837, with the classification of causes of death coded using the Ninth Revision of the International Classification of Diseases (ICD9) since 1979. Historically there have been inaccuracies in this data due to lack of registrations, but today few, if any, deaths escape registration, and the cause of almost all registered deaths are certified by a medical practitioner or coroner. However, currently only 26 percent of death certificates are signed after a post mortem, which gives the most precise diagnosis. This is of particular importance since other studies have found marked disagreement between autopsy reports and death certificates (Charlton 1997). In addition, it has been documented that converting death certificate information to a single cause of death may fail to identify the combination of diseases

which have been attributed by the certifier as contributing to death (Ashley 1997). One should be aware of these factors when using these data.

I have used these data for 1993 as the source of total and cause specific mortality rates, by age and sex, for input to the models.

4.5 General Household Survey

The General Household Survey (ONS 1998) is a multi-purpose survey providing information on aspects of housing, employment, education, health and social services, transport, population and social security. The Survey has been carried out annually since 1971 by OPCS, and by the Social Survey Division of the Office of National Statistics (ONS) since 1996. It is a continuous survey based on samples of the general population of Great Britain resident in private, non-institutional households. The last Survey, carried out from April 1996 to March 1997, interviewed 17,043 people aged over 16 in 9,158 households.

Although the Survey is carried out every year; it is not a longitudinal survey, but a repeated cross-sectional survey with a different sampled population each year. In addition, the same sample questions are not asked each year, in particular questions regarding cigarette consumption were not asked every other year starting from 1977.

I obtained the GHS data sets for the period 1973 to 1990 from the ESRC Data Archive at Essex University. The data were supplied on CD-ROM as SPSS portable files, from which I extracted data in the format required by the models using SPSS Version 8.0. In particular, I have used the data on smoking to build up smoking prevalence over time by sex, age group and cigarette smoking exposure category for input as trends into the models, therefore it is necessary to be aware that one is using these data as a proxy for longitudinal data.

4.6 Health Survey For England

The Health Survey for England (Bennett 1995) was first commissioned in 1991 by the Department of Health (DoH) from the Office of Population Censuses & Surveys (OPCS), and has been produced for each year since. Its objective was to obtain information on aspects of health related to cardiovascular disease and associated risk factors, and nutrition. The Survey initially aimed to select a representative sample of adults (aged 16 or over) living in private households in England; the 1995 and 1996 Surveys also covered children aged 2 to 15 living in households selected for the survey. The sampling was achieved using a multi-stage random probability design. In 1991 3,242 adults completed a full interview, and by 1996 this sample size had increased to 20,328 persons (16,443 adults and 3,885 children).

I have been using the 1993 Survey data set, which has a total of 16,569 adults, as my main source of CHD risk factor prevalence data. I obtained the data set from the ESRC Data Archive at Essex University. Again the data were supplied on CD-ROM as SPSS portable files, and I extracted prevalence data in the format required by the models using SPSS Version 8.0.

The main aims of the 1993 Survey were:

- to provide baseline data for a nationally representative sample from which to monitor trends in the nation's health,
- to estimate the proportion of people in England in whom specific conditions had been identified,
- to estimate the prevalence of certain risk factors associated with these conditions,
- to see how different subgroups in the population vary in their likelihood of having specified conditions or risk factors,

- to assess the frequency with which particular combinations of risk factors are found, and in which groups they predominate,
- to monitor progress towards some of the specific targets (in connection with blood pressure and obesity) relating to CVD in the *Health of the Nation* initiative,
- to provide estimates for the above measures for Regional Health Authorities in England,
- to provide more precise estimates for other relatively small subgroups of the population,
- to improve the value of the survey for monitoring purposes by increasing the precision of all estimates.

Although the Survey initially sampled 16,569 adults; of these only 81% had their blood pressure measured and only 72% agreed to give a blood sample. There was a particular shortfall amongst those aged 16-24 and those aged over 75. Therefore the final sample of 12055 does not match the age group distribution of the mid-1993 England population exactly.

4.7 Allied Dunbar National Fitness Survey

The Allied Dunbar National Fitness Survey (Sports Council and Health Education Authority 1992) was conducted in 1990, and its aim was to produce a description of the different patterns of physical activity and levels of fitness prevalent among the adult (16 years and over) population of England. The Survey was carried out by OPCS in 1990 for the DoH, the Sports Council and the Health Education Authority (HEA), and was financed by Allied Dunbar Assurance plc. Overall 4,316 individuals were interviewed, however only 56% of these people went on to take part in a physical appraisal (Fentem

1994), and there are no figures comparing this group's age and sex structure to that of the population of England. A further 2622 interviews were carried out using the same questionnaire in 1991 as the Health Education Authority National Survey of Activity and Health, and the reported data have been amalgamated with the data from the Allied Dunbar National Fitness Survey. I have used these amalgamated survey data, which was supplied to me by the HEA, to obtain the prevalence of physical activity levels in the population.

4.8 Morbidity Statistics from General Practice

In the 1950s it was recognised that General Practitioners (GPs) consultation information could provide useful indicators of the health of the population, and that information on prevalence trends in sickness could help inform health service practitioners and planners. The first study took place in 1955-6, while the fourth, and most recent, study was commissioned by DoH and conducted in 1991-2 under the guidance of a Project Board representing DoH, the Royal College of General Practitioners and OPCS (McCormick 1995). This study covered a one per cent sample of the England & Wales population, which comprised 502,493 patients at 468,042 person years at risk, taken from the NHS lists of 60 volunteer practices.

The main aims of the study were:

- to examine the pattern of disease seen by GPs, by the age, sex and socio-economic status of the patient and to give an indication of the care provided,
- to provide information to those planning health care resources,
- to compare the results of this study with those of the earlier studies.

As this was a self-selected sample of practices their characteristics were slightly different from those of all practices in England & Wales. They were larger, employed

more ancillary staff and had younger principal doctors. However, the sample population was representative of England & Wales in terms of age, sex, marital status, tenure of housing, economic position, occupation and urban/rural locations. There were differences in the proportions by social class, under-representation of ethnic minority groups and of people living alone.

When interpreting the data one must be conscious of the fact that not everyone consults their GP, therefore there is an unknown amount of undetected morbidity in the population. Secondly one must be aware of possible errors in the capture, coding and processing of the data (Ashley 1997). With the computerisation of practices this may be less of a problem, although misclassification of diseases may still exist (Fraser 1997). Caution should still be used in interpreting the data (Coulter 1989).

This survey was used to provide data on the prevalence and incidence of coronary heart disease and cerebrovascular disease in the population, although this was done with some caution since the incidence measure used counts a person several times if they experience more than one distinct episode of a disease during the year.

4.9 Hospital Episode Statistics

The Hospital Episode Statistics (HES) (DoH 1995) system was introduced in 1987 to provide patient-based data on hospital activity, replacing the Hospital Inpatient Enquiry and the Mental Health Enquiry. HES covers all specialities and includes private patients treated in NHS hospitals, and is based on consultant episodes, with the clinical speciality based on the clinical qualifications of the consultant. HES data have been published for each financial year from 1988-89.

The data are collated in the Hospital Patient Administration system, and extracts of these data are submitted to ONS, formerly OPCS, via the District and Regional information systems. The data contains the following three types of episodes:

- unfinished - when a patient is still occupying a bed,
- incomplete - when the end of data of a patient episode is recorded, but the diagnosis has not been coded,
- completed - when all data items have been coded.

These data refer to episodes confined to each year separately, therefore a first episode in that year cannot be distinguished as a new episode or a recurrent episode. In addition, as patients do not have unique identifiers it is difficult to discern new patients from patients with recurrent episodes, and this is only possible by fuzzy matching on sex, date of birth and post code, which is not ideal.

As with the GP statistics, not everyone is admitted to hospital for a disease, therefore patients admitted may not be representative of all persons with a disease in terms of numbers or severity. Also the factors such as accessibility, bed availability, changes in diagnostic practices and changes in treatment will affect discharge rates (Fraser 1997).

These data had been used to obtain first and recurrent myocardial infarction and stroke rates for England, and this was done using fuzzy matching by IBM, who supplied me with tables of events by age and sex.

4.10 Cancer Registration

Cancer registration (ONS 1997) is carried out by ten independent regional registries in England & Wales, which collect data on cancers incident in their regions, and submit a standard data set of these registrations to ONS. There is a similar system in Scotland, which is co-ordinated by the Information and Statistics Division of the NHS in Scotland Services Agency.

The last published data set for England & Wales was for 1991, which presented data on patients who were first diagnosed with cancer by site in 1991 and whose registrations were received at ONS by September 1997.

The main concerns with cancer registration is the level of completeness of ascertainment, accuracy of the items registered and the effectiveness of follow-up from which survival data are calculated (Charlton 1997), with completeness varying according to the period of diagnosis (Smith 1997). It has been shown that in recent years completeness has been relatively high, although there is some loss between regional and national levels (Swerdlow 1993). Diagnosis is relatively accurate, although errors and omissions on items such as date of registration, date of birth, histology and occupation still occur, but interpretation of these data is still feasible (Ashley 1997). The implementation of recommendations to link registration with information on deaths has facilitated the calculation of survival statistics (Charlton 1997). However, this relies on the completeness and accuracy of registration being good, but these are improving with the development of computer technology.

I have used cancer registers to obtain data on incidence, stage of diagnosis and survival for lung and breast cancer. These data were supplied to me by the Thames Cancer Registry and ONS.

4.11 Oxfordshire Stroke Register

The Oxfordshire Community Stroke Project (Bamford 1988) was a prospective study of acute cerebrovascular disease in a community of about 105,000 people from 1981 to 1986. The study combined the rapid clinical assessments of patients with accurate diagnosis of the pathological type of stroke by computed tomographic scan or necropsy, whether they were admitted to hospital or not. Over the study period 675 cases of clinically definite first-ever stroke were registered.

In terms of comparing the structure of the study population with that for England & Wales, the sample over represented the 15 to 44 year olds, and under-represented the other age groups. Also due to the study population coming just from Oxfordshire the sample was probably not representative in terms of social class and ethnic make up.

These data were supplied by Dr Mike McDowall of the Oxfordshire Community Stroke Project as a Dbase IV file, which I transferred to SPSS Version 8.0 and then converted into a SPSS file. From this file I calculated the incidence and prevalence of first and recurrent strokes.

4.12 Scottish MONICA Data

The WHO MONICA (monitoring trends and determinants in cardiovascular disease) Project monitored from the early 1980s, over 10 years, trends in cardiovascular mortality and coronary heart disease and cerebrovascular disease morbidity. In addition, it assessed the extent to which these trends were related to changes in known risk factors, daily living habits, health care, and socio-economic features measured at the same time across 37 populations in 21 countries (Tunstall-Pedoe 1999 and WHO/OMS 1997).

The Project collected data on (WHO/OMS 1997):

- standardised coronary and stroke event registration,
- medical care of patients before, during and after an attack,
- risk factor measurements, with focus on smoking habits, blood pressure and its treatment, serum or plasma total and HDL cholesterol, height, weight, marital status, and education,

- aspects of recent interest, such as awareness and treatment of high cholesterol, use of aspirin and contraceptive pills, and on menopause,
- population size and mortality, which was routinely available,
- medical services data.

The coronary events recorded in MONICA were defined as non-fatal if the individual survived to 28 days from onset, and as fatal if CHD death occurred before or after admission or discharge from hospital but with 28 days of onset (Tunstall-Pedoe 1999).

One of the MONICA populations was all 25 to 64 year old residents of Glasgow city north of the river Clyde in Scotland (mean population of 130,000), followed from 1985 to 1994 (Tunstall-Pedoe 1996), although routine mortality data were missing for 1993 (WHO/OMS 1997). Table 4.1 describes the coronary events recorded for the Scottish MONICA population by sex.

Sex	Official CHD Deaths	Number of Events		
		Fatal	Non-fatal	Coronary
Males	2934	2627	2823	5450
Females	942	1018	1125	2143

Table 4.1 - Scottish MONICA coronary events by sex (Tunstall-Pedoe 1999).

Data were supplied from this population on MI and death coronary incidence, and case fatality by Professor Simon Capewell in 1998, then at the University of Glasgow.

The main problem with applying these data to the population of England and Wales is that event rates and mortality are some 20-25% higher in Scotland, in addition to showing marked North/South gradients and socio-economic gradients (Capewell personal communication 1998). As well as this population having a lower socio-economic status, and higher risk factor levels and mortality for Scotland (WHO/OMS 1997).

4.13 Discussion

The data sources described in the chapter are far from perfect. Even national data sources that have been routinely collected over a long period, such as the Mortality Statistics, are not free of inaccuracies. Although not ideal I think that these data are still useable, but one must be aware of their limitations.

Population data for Census years will be the most accurate, and the further away a model's base year is from a Census year the less accurate the data will be. Ideally one should base models on, or as close as possible to Census years. For my models I chose 1993 since it was the last year of the Health Survey for England that data on cholesterol levels were collected, as well as alcohol, blood pressure and smoking, and it was only two years after the last Census.

My source of risk factor data was the Health Survey for England 1993. Although this was designed to be a nationally representative sample; only 72% of the sample had a complete risk factor profile for cholesterol, alcohol, blood pressure and smoking measurements. One needs to be aware of this, particularly if modelling interventions aimed at the very young and very old, the two groups most under-represented in the Survey.

Sources of morbidity data, such as the Hospital Episode Statistics and the Morbidity Statistics from General Practice, are the most problematic in terms of being representative, accurate and complete. I would express the need for extreme caution when using such data sources.

Another issue to be aware of when applying regional data, such as those from the Oxfordshire Stroke Register and the Scottish MONICA Project, to other regions or nationally is that factors like risk factor profiles, social class or ethnic mix, and hence disease incidence and mortality, may be quite different, so making the data less applicable.

In addition to availability of data, the form in which the data are available is important. I was fortunate that I was able to obtain many of these data sources in an electronic form, and this allowed me to extract data for the models in any format needed. However, had I had to rely on just using tables from published reports it would have meant that I would have had less flexibility in setting up the categories within the model, and so may not have been able to match such things as risk factor exposure categories by age and sex to published relative risks.

When I was working on the Biomed collaboration (see Chapter 9) I was made aware that the UK has a far greater range of data available than the Netherlands, Sweden and Denmark. In terms of the availability of data important for public health modelling, such as representative and continuous risk factor exposure data at a population level, I was not constrained by problems of lack of data as the modellers from the other countries were. Although the data were not perfect, modellers in the UK are fortunate to have much better access to data sets on risk factors and disease, especially in recent years with the availability of the raw data from national surveys held by the ESRC Data Archive at Essex University.

Overall, I feel that this chapter highlights the need for the collection of health data at a national level. Incredibly, although CHD is seen as the major cause of premature death in the UK (Audit Commission 1995), there are no national registers of incidence, prevalence or survival. Surveys such as the Health Survey for England should consistently measure all the CHD risk factors from survey to survey. Not only are such data essential for monitoring the health of the population and for evaluating the effects of health interventions (Winkelstein 1981), but are vital for use in public health modelling.

4.13 Conclusion

I have already mentioned that the models produced can only be as good as the data that are input into them, since they are so heavily reliant on data. However, there will never be perfect data sets that are free of all diagnosis and coding error, or that have 100% completeness. To some extent one must make do with what data are available. Some mainly reliable data are better than no data, although when using these data it is important to be aware of their limitations and of how representative the statistics they present are. Bad data, which may be estimated or not representative of the population they are to be applied to, are not better than no data since one will not be able to support the validity of their use to policymakers. I feel that it essential for modellers to understand the input data for models, otherwise they will never be able to fully or intelligently interpret the results their models produce.

Section 2: PREVENT

Chapter 5 – The PREVENT Model

5.1 Introduction

In this chapter I describe my early work on Prevent, when I first adapted it for use with an England & Wales population. I encountered a number of problems, and had to revise my original plans quite considerably.

5.2 Getting Started With PREVENT

5.2.1 Installation

The Prevent executable programme, PREVENT.EXE, and the data input programme, PREVDATA.EXE, are installed on to a personal computer (PC) using the MS-DOS operating system by running the PREVINST.EXE programme. This creates a PREVENT directory with a DAT1 subdirectory, which contains the original Dutch data set, and a TMPDAT1 subdirectory, which is used for writing temporary data files that Prevent uses during a simulation run.

The next stage was to create and input an England & Wales data set using the PREVDATA.EXE programme. This is a menu driven programme that allows the user to create the risk factor and the population data files used by the Prevent programme. In addition, the software will, to a certain extent, check for improbable input and errors of data entry. Details of the data input process are outlined in the Prevent User Manual (Barendregt 1990).

Prevdata is a useful tool for the initial input of data for a Prevent model since it guides the user through the data input process in a structured and methodical fashion. However, once this process has been completed and the user wants to return to edit their data files it can become quite a laborious task. In particular, when editing risk factor data one must run through each input step, in which one will leave the current data unchanged, until one finds the appropriate input screen for editing a specific section of data. After a

while, having identified which data file contained which data, I found it easier to edit the actual data files in a text editor rather than using the Prevdta programme.

5.3 PREVENT Input Data Files

The first step which was necessary before I could edit the data files directly was to identify and document the files, since the Prevent Manual only had limited information on the files, just specifying that the file names were reserved names, but not giving details of their contents. Appendix A outlines the contents of the input files used by Prevent.

The data files can be classified into model settings files, population data files, risk factor data files and cause specific mortality data files.

5.3.1 Model Settings Files

The settings for each population model are written to a DAT#INST.DAT file, where # signifies the number assigned to a population's data set within the model, and is referred to in the User Manual as the log file. It is created by Prevdta, but is also used by Prevdta and Prevent since it contains details of the following settings:

- the base year for the model,
- the number of risk factors,
- the number of causes of death,
- the risk factor names,
- the names of the cause of death,
- the number of causes of death affected by a risk factor,
- the cause of death affected by a risk factor,
- the times for each cause of death to be affected by a change in risk factor exposure,
- the number of age groups for the risk factor prevalence data,
- the age group labels,
- the number of risk factor exposure categories,

- the risk factor exposure category labels.

Appendix B contains the Prevent log file DAT1INST.DAT with my comment statements explaining each section of the code.

Once I had become familiar with the Prevent log file I would edit it using a text editor, such as Windows Notepad, to change any of the above settings as I found it less laborious than using the Prevdata programme.

5.3.2 Population Data

The population data were derived from routine data source collected, or projected by ONS (formerly OPCS), as detailed in the Chapter 4 - Data Sources. These data are:

- general mortality probability per 100,000 for the base year in one year age groups, by sex.
- birth projections from the base year to the base year plus 50 years as absolute numbers, by sex.
- life expectancy of the 95 year olds for the base year, by sex.
- population structure for the base year in one year age groups, by sex.

It is important to note that mortality probability is used rather than mortality rate. In addition, birth projection data for England & Wales are not produced by sex, and so it was necessary for me to divide the published figures by the current male to female ratio for the population.

The life expectancy of the 95 years olds is used with the general mortality data by the Prevdata programme to produce a data file of life expectancy in one year ages groups, by sex, which is used by the Prevent model. Consequently it is essential to use Prevdata to input these data, as well as giving a more structured input interface than a text editor.

5.3.3 Risk Factor Data

The risk factor prevalence data were extracted from population surveys, such as the General Household Survey and the Health Survey for England, while the relative risk data were taken from the original Dutch model, which were obtained from the literature (Gunning-Schepers 1989). The data input files for each risk factor were:

- prevalence of exposure to the risk factor in the base year, by sex, age group and exposure category;
- relative risks of a specific cause of death for a risk factor by sex, age groups and exposure category;
- calculation options: cohort, percentage outflow as a percentage of the exposed to a risk factor;
- calculation options: cohort, percentage inflow as a percentage of the exposed to a risk factor;
- calculation options: age groups, percentage outflow as a percentage of the exposed to a risk factor;
- calculation options: age groups, percentage inflow as a percentage of the exposed to a risk factor;
- percentage outflow as a percentage of the exposed to a risk factor, if separate cohort or age groups trends have not been specified;
- percentage inflow as a percentage of the exposed to a risk factor, if separate cohort or age groups trends have not been specified.

Prevent can be run under one of two risk factor modes. It can be run either in the cohort mode when one assumes that the exposure to a risk factor is predominantly a

characteristic of a birth cohort, such as behavioural risk factors like smoking and drinking, or in the age group mode when one assumes that the characteristics of being exposed to a risk factor are predominately age dependent, such as hypertension. Separate risk factor trend data files are needed for each of these modes.

The stratification of these data will be dictated by the stratification of the relative risks of mortality for each risk factor, in terms of the number of age groups, the age groups categories and the risk factor exposure categories, as input to the log file.

5.3.4 Cause Specific Mortality Data

For each cause of death to be included in the model mortality probability per 100,000 in five year age groups by sex is required. These data were derived from routine mortality data published by ONS.

5.4 PREVENT Output

The results of a Prevent simulation run are produced in terms of disease specific and aggregated output, and this output can be in either graphical or tabular form.

5.4.1 Disease Specific Output

The disease specific outputs produced by Prevent are:

- Etiologic fraction - the percentage mortality from a disease that can be attributed to a risk factor;
- Potential and Trend Impact Fraction - the percentage mortality from a disease that is prevented by the intervention, or the autonomous trends, respectively;
- Disease specific mortality per 100,000;
- Disease specific mortality;

- Disease specific mortality reduction.

5.4.2 Aggregated Output

The aggregated outputs produced by Prevent are:

- Total mortality - mortality from all causes of death, including those not explicitly modelled;
- Total mortality reduction - the total mortality of the intervention is subtracted from the total mortality of the reference population;
- Potential years of life gained – the years of life gained due to the autonomous trends and the intervention;
- Actual years of life gained - the difference between the reference and the intervention population;
- Survival curve;
- Expectancy of life at birth.

Full details of the output are given in Appendix B of the Prevent User Manual (Barendregt 1990).

Originally the output could be written to the screen, to a printer, to a graphic or a text file. In addition, it was possible to combine the output from several runs in one table or graph. However, I found the output formats for the graphs and tables quite limiting, such as only one style of graph being available, not being able to change the scales of the graphs or the style of the lines, and not being able to change the sub-divisions of the tables. I therefore asked Dr Jan Barendregt, Prevent's programmer, to add an output option which would write the results to a comma delimited file, which could then be

imported into a spreadsheet programme, such as Microsoft Excel. This allowed me to produce tables and graphs using a great variety of formatting options, such as using different line and bar graph styles, changing the scales of graphs, easily combining a number of Prevent runs, and allowing greater sub-division or aggregation of tables by age groups or sex.

5.5 Adapting PREVENT

Initially I intended to improve the input and output of data for the Prevent model by reprogramming the model. I visited Dr Jan Barendregt at Erasmus University in Rotterdam to obtain the source code for the programmes, any documentation and to discuss the feasibility of reprogramming the model.

The source code was written in Turbo Pascal, which I am familiar with. However, there was no documentation at all for the programme in terms of comment statements, flow diagrams or variable glossaries. In addition, the variable names used within the programmes were abbreviations of Dutch words, and so would not have been intuitive for me to discern. Most importantly Dr Barendregt admitted that Prevent had been his first programming exercise, and it had been done within a limited timeframe since it had to be completed for Prof. Gunning-Schepers' PhD. Consequently he had not followed a structured programming style, which at the time was not seen as important as no-one had envisaged Prevent being developed by other researchers.

After some thought, and discussions with Dr Barendregt, Prof. Gunning-Schepers and Dr Margaret Thorogood, I decided that the time that would be needed to unravel the source code, and to understand the structure and the workings of the programme was not warranted by the expected outcome in terms of the use of Prevent. I therefore decided to make the model more easy to use by other, non-programming, changes which will be detailed in later chapters, such as developing a spreadsheet model to calculate risk factor trends, and allowing the movement of individuals from one risk factor exposure category to another, rather than to the non-exposure category.

5.6 Validation

As mentioned in Chapter 2 it is difficult to validate models such as Prevent. Such methods as historical testing, where the known changes in risk factor prevalences in the past are simulated to verify whether the model can produce current mortality patterns, are not possible, because Prevent can only take into account the effect of the reductions in the risk factors included in the model to explain changes in mortality. Prevent cannot account for risk factors not included in the model, or improvements in medical treatment which increase survival and hence reduce mortality. However, I have tried to validate the parameters which are used in the model by choosing the most appropriate data based on the available literature and data sources. Even this can sometimes be problematic, with data from a different population, or only a subgroup of a population having to be used when no data are available for the population of interest, which might be quite unlike the population for which data are available.

5.7 Discussion

One of the attractions of the Prevent model is that it uses input data that are routinely available for the England & Wales population. Although some time and effort was required to understand and identify the input data files, due to a lack of documentation; having done so it is a relatively straightforward procedure to input a new data set, using the Prevdata programme and a text editor.

The lack of documentation for the Prevent source code means that the model can not be quickly or easily adapted by other programmers. The original programmer is the only person able to make alterations to the model. This is a major weakness in terms of developing the model for further use, and for use by other people. On any research programme there will be a change in personnel over time. Without adequate documentation for a model, when the key individual with the knowledge of its workings leaves, or changes research projects, any further development will be almost impossible, unless considerable time and effort is spent to rediscover the model's inner workings.

Validation of the Prevent model is not possible in terms of historical testing, but, to a certain extent, “face-validity” of the parameters used by the model can be checked in terms of the appropriateness of the input data used for a particular population. I feel that this situation is not ideal, but I would agree with Kotva (Kotva 1992) that due to models being unable to capture all the complexities of health interventions and to lack of data it may be impossible to validate such models in terms of a “gold standard”. However, one is justified in using unvalidated models as long as one draws attention to the fact that the model is unverified and that its use can only yield results of a hypothetical nature.

5.8 Summary

This chapter describes the installation of the Prevent programme, the input data files required to run the model, and the types of output produced by the model. In addition, the barriers to adapting, by re-programming, and validating the model are discussed.

Chapter 6 - PREVENT Trends And Limitations

6.1 Introduction

On first impressions, Prevent is a seductive computer model, with its "user-friendly" menu driven screens for running simulations. The user can believe that it is a simple model to use and understand. However, on beginning to use the model to simulate actual interventions one becomes aware of the problems with using it in terms of the limitations of what it can simulate. These limitations are not made explicit in the model's literature.

The first part of this chapter will concentrate on the Prevent risk factor trends, in particular my work on calculating the trend inflow and outflow values used by Prevent from past prevalence data, and in producing spreadsheets to aid with the creation and input of the Prevent trend files.

In the second part of this chapter I will identify the limitations I have noted through my use of the Prevent model, when I attempting to model risk factor interventions for policymakers. In addition, I will outline how I overcame those problems that could be solved, and explain why some problems cannot be solved by the user.

PART I

6.2 PREVENT Trends

Some of my earliest work on the Prevent model, while constructing the England & Wales version, involved working on the calculation of risk factor trend data. While trying to input past changes in risk factor exposure over time into the model I realised that I did not understand exactly what had to be input into Prevent, nor was it made clear in the documentation what was required.

Having talked to other researchers who had used the model I realised that defining and calculating the trends for Prevent was considered a problematic area. Some of this has

been due to a lack of clear documentation concerning what data need to be input into Prevdta and how these data are input. In addition, confusion had arisen due to the need to define separate trends for using Prevent in the age and the cohort modes, see Chapter 5, as it was unclear what were the differences required for the calculations using these options. Other researchers had just used the default trends which specified no risk factor trends in the past and a one percent yearly reduction in prevalence of all risk factors in the future.

Trends within Prevent can be run either in the cohort mode when one assumes that the exposure to a risk factor is predominantly a characteristic of a birth cohort, such as behavioural risk factors like smoking and drinking, or in the age group mode when one assumes that the characteristics of being exposed to a risk factor are predominately age dependent, such as hypertension. Consequently separate risk factor trend data files are needed for each of these modes, which rely on different methods of calculation.

Professor Gunning-Schepers explained to me how Prevdta worked, and this clarified what data need to be input and how these data are input. The trends can be split into two types:

- past trends, which are needed as far back as $LAG + LAT$ years from the base year (different for each risk factor/disease combination),
- future trends, which can be specified for up to 50 years after the base year. These trends need only be default trends, since future trends can also be specified during each Prevent run.

LAT is the time between the cessation of exposure and when a person's relative risk begins to decrease, while LAG is the time between a person's relative risk beginning to decrease and when it reaches its lowest value for the ex-exposed category, the remnant relative risk.

Prevent also distinguishes between inflow and outflow trends:

- Inflow trends are the trends from non-exposed to an exposed category, and are specified by a positive number,
- Outflow trends are the trends from an exposed category to ex-exposed, and are specified by a negative number.

6.3 Calculating Past Trends

6.3.1 Cohort Specific Risk Factor Trends

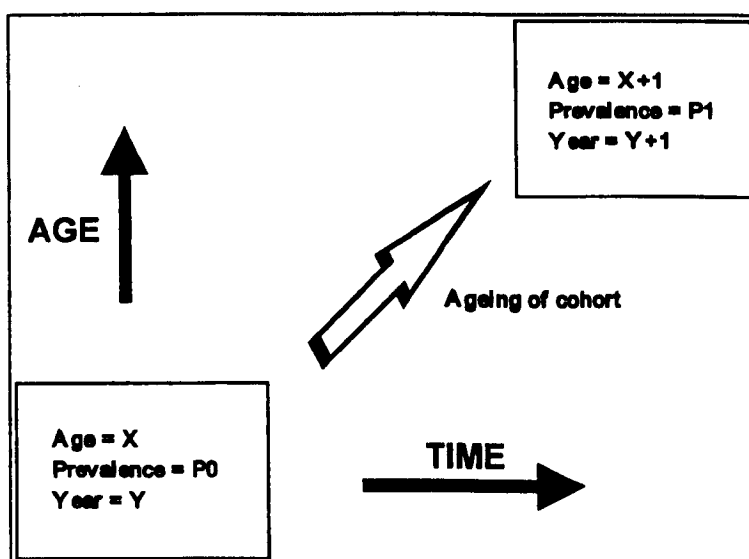

Figure 6.1 – Ageing of a cohort.

Trends are defined as the percentage increase or decrease in prevalence of the currently exposed. This can be visualised as above in Figure 6.1.

$$\text{Cohort trend for age group X from year Y to Y+1} = (P1 - P0) / P0$$

Dr Perla van de Mheen from the Amsterdam Medical Centre had undertaken some work assessing smoking trends using Prevent, during the course of which she produced a spreadsheet to calculate trends. However, the way in which she had set up the spreadsheet meant that the user had to input values for the trends by trial and error until they resulted in the observed prevalences, rather than calculating the trend values from

the observed prevalences. This method was unwieldy, and it would entail a considerable amount of work if one was to consider using this method to produce a data set for all the risk factors and their exposure categories.

As a consequence Ms Rianne Welvaarts, who was working with Professor Gunning-Schepers at the Amsterdam Medical Centre, and I adapted Dr van de Mheen's spreadsheet so that the trend values were calculated from the observed prevalences.

The first step in calculating the past trends is to collect the prevalence data for each risk factor category by age group and sex, for each year if possible, as far back as required (LAT + LAG years). Most probably there will be years where there are no prevalence data, and so the missing prevalences must be interpolated. The method of interpolation will be conditional on whether the risk factor in question is age group or cohort dependent. I have decided not to use concise mathematical notation for the equations in order to avoid confusion, and to make them more explicit for translating to a spreadsheet model.

Age Bands	Risk Factor Category Prevalence							
H	P(H ₀)	P(H ₁)	X(H ₂)	P(H ₃)	X(H ₄)	X(H ₅)	P(H ₆)	P(H ₇)
G	P(G ₀)	P(G ₁)	X(G ₂)	P(G ₃)	X(G ₄)	X(G ₅)	P(G ₆)	P(G ₇)
F	P(F ₀)	P(F ₁)	X(F ₂)	P(F ₃)	X(F ₄)	X(F ₅)	P(F ₆)	P(F ₇)
F to J	P ₂ (0)	P ₂ (1)	X ₂ (2)	P ₂ (3)	X ₂ (4)	X ₂ (5)	P ₂ (6)	P ₂ (7)
Trend		T ₂ (1)	T ₂ (2)	T ₂ (3)	T ₂ (4)	T ₂ (5)	T ₂ (6)	T ₂ (7)
E	P(E ₀)	P(E ₁)	X(E ₂)	P(E ₃)	X(E ₄)	X(E ₅)	P(E ₆)	P(E ₇)
D	P(D ₀)	P(D ₁)	X(D ₂)	P(D ₃)	X(D ₄)	X(D ₅)	P(D ₆)	P(D ₇)
C	P(C ₀)	P(C ₁)	X(C ₂)	P(C ₃)	X(C ₄)	X(C ₅)	P(C ₆)	P(C ₇)
B	P(B ₀)	P(B ₁)	X(B ₂)	P(B ₃)	X(B ₄)	X(B ₅)	P(B ₆)	P(B ₇)
A	P(A ₀)	P(A ₁)	X(A ₂)	P(A ₃)	X(A ₄)	X(A ₅)	P(A ₆)	P(A ₇)
A to E	P ₁ (0)	P ₁ (1)	X ₁ (2)	P ₁ (3)	X ₁ (4)	X ₁ (5)	P ₁ (6)	P ₁ (7)
Trend		T ₁ (1)	T ₁ (2)	T ₁ (3)	T ₁ (4)	T ₁ (5)	T ₁ (6)	T ₁ (7)
Year	Y(0)	Y(1)	Y(2)	Y(3)	Y(4)	Y(5)	Y(6)	Y(7)

Table 6.1 – Risk factor prevalence and trends over time by age and age group

Prevalences will only be known for age groups rather than single age bands, in the above example labelled $P_1(0)$, $P_1(1)$, $P_1(3)$, $P_1(6)$ and $P_1(7)$ for age group A to E, see Table 6.1. In addition, the data may be unavailable for some years, as signified by $X_1(2)$, $X_1(4)$ and $X_1(5)$, and so these value will be calculated by linear interpolation:

$$X_1(2) = P_1(1) + (P_1(3) - P_1(1) / 2)$$

and

$$X_1(4) = P_1(3) + (P_1(6) - P_1(3) / 3)$$

and so on.

Next, starting with year $Y(0)$ one assumes that the prevalence of a risk factor category for an age group is distributed evenly across each one year age band.

Using:

$$P_1(0) = (P(A_0) + P(B_0) + P(C_0) + P(D_0) + P(E_0)) / 5$$

therefore:

$$P_1(0) = P(A_0) = P(B_0) = P(C_0) = P(D_0) = P(E_0)$$

As a birth cohort ages each year its prevalence should be tracked diagonally across the table, as shown in Figure 6.2 below.

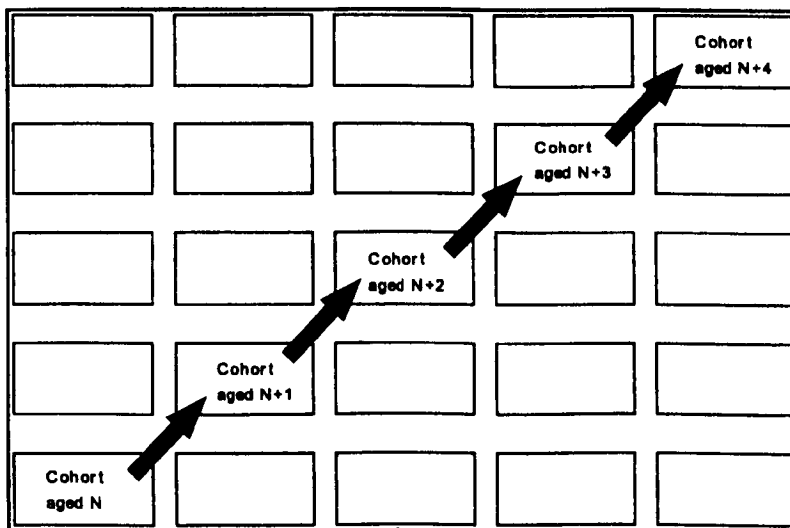

Figure 6.2 – Ageing of a birth cohort.

For instance, taking the birth cohort of age band A in year $Y(0)$ which has a risk factor prevalence $P(A_0)$; after one year it has a prevalence of $P(B_1)$, and after six years it has a prevalence of $P(G_6)$.

The trend is then interpolated for an age group as it ages one year, so $T_1(1)$ is the trend for age group A to E as it ages to age groups B to F from year $Y(0)$ to $Y(1)$. Consequently, from:

$$T_1(1) = (P(B_1) - P(A_0)) / P(A_0)$$

therefore:

$$P(B_1) = P(A_0) (1 + T_1(1))$$

Also:

$$P_1(1) = [P(A_1) + P(B_1) + P(C_1) + P(D_1) + P(E_1)] / 5$$

therefore:

$$P_1(1) = [P(A_1) + P(A_0) (1 + T_1(1)) + P(B_0) (1 + T_1(1)) + P(C_0) (1 + T_1(1)) + P(D_0) (1 + T_1(1))] / 5$$

And so:

$$T_1(1) = [(5 * P_1(1) - P(A_1)) / (P(A_0) + P(B_0) + P(C_0) + P(D_0))] - 1$$

In Prevent one can set the prevalence of a risk factor for the in-growing cohort, and unless data are available it is assumed that the youngest cohort $P(A_1)$ in year $Y(1)$ has the same prevalence as the youngest cohort $P(A_0)$ in year $Y(0)$, i.e. that the risk factor behaviour is the same and that there has been no change in the behaviour between the two youngest cohorts in the model in one year. So using:

$$P(A_1) = P(A_0)$$

Therefore:

$$T_1(1) = [(5 * P_1(1) - P(A_0)) / (P(A_0) + P(B_0) + P(C_0) + P(D_0))] - 1$$

While for age groups other than the youngest, such as age group F to J, the following applies:

$$P_2(1) = [P(F_1) + P(G_1) + P(H_1) + P(I_1) + P(J_1)] / 5$$

$$P_2(1) = [P(E_0) (1 + T_1(1)) + P(F_0) (1 + T_2(1)) + P(G_0) (1 + T_2(1)) + P(H_0) (1 + T_2(1)) + P(I_0) (1 + T_2(1))] / 5$$

$$T_2(1) = [5 * P_2(1) - P(E_0) (1 + T_1(1)) / P(F_0) + P(G_0) + P(H_0) + P(I_0)] - 1$$

For the oldest age group, 65 to 95 years olds, the risk factor prevalence for the whole age group is weighted to give a higher prevalence in the 65 to 77 year olds, as follows:

$$P_{65-95}(1) = \{ 2 [P(65_1) + P(66_1) + P(67_1) + P(68_1) + P(69_1) + P(70_1) + P(71_1) + (72_1) + P(73_1) + P(74_1) + P(75_1) + P(76_1) + P(77_1)] + [P(78_1) + P(79_1) + P(80_1) + P(81_1) + P(82_1) + P(83_1) + P(84_1) + P(85_1) + P(86_1) + P(87_1) + P(88_1) + P(89_1) + P(90_1) + P(91_1) + P(92_1) + P(93_1) + P(94_1) + P(95_1)] \} / 44$$

$$P_{65-95}(1) = \{ 2 [P(64_0) (1 + T_{60-64}(1)) + P(65_0) (1 + T_{65-95}(1)) + P(66_0) (1 + T_{65-95}(1)) + P(67_0) (1 + T_{65-95}(1)) + P(68_0) (1 + T_{65-95}(1)) + P(69_0) (1 + T_{65-95}(1)) + P(70_0) (1 + T_{65-95}(1)) + P(71_0) (1 + T_{65-95}(1)) + P(72_0) (1 + T_{65-95}(1)) + P(73_0) (1 + T_{65-95}(1)) + P(74_0) (1 + T_{65-95}(1)) + P(75_0) (1 + T_{65-95}(1)) + P(76_0) (1 + T_{65-95}(1)) + P(77_0) (1 + T_{65-95}(1))] + [P(78_0) (1 + T_{65-95}(1)) + P(79_0) (1 + T_{65-95}(1)) + P(80_0) (1 + T_{65-95}(1)) + P(81_0) (1 + T_{65-95}(1)) + P(82_0) (1 + T_{65-95}(1)) + P(83_0) (1 + T_{65-95}(1)) + P(84_0) (1 + T_{65-95}(1)) + P(85_0) (1 + T_{65-95}(1)) + P(86_0) (1 + T_{65-95}(1)) + P(87_0) (1 + T_{65-95}(1)) + P(88_0) (1 + T_{65-95}(1)) + P(89_0) (1 + T_{65-95}(1)) + P(90_0) (1 + T_{65-95}(1)) + P(91_0) (1 + T_{65-95}(1)) + P(92_0) (1 + T_{65-95}(1)) + P(93_0) (1 + T_{65-95}(1)) + P(94_0) (1 + T_{65-95}(1))] \} / 44$$

$$T_{65-95}(1) = \{ 44 * P_{65-95}(1) - 2 * P(64_0) (1 + T_{60-64}(1)) / [2 * P(65_0) + 2 * P(66_0) + 2 * P(67_0) + 2 * P(68_0) + 2 * P(69_0) + 2 * P(70_0) + 2 * P(71_0) + 2 * P(72_0) + 2 * P(73_0) + 2 * P(74_0) + 2 * P(75_0) + 2 * P(76_0) + 2 * P(77_0) + P(78_0) + P(79_0) + P(80_0) + P(81_0) + P(82_0) + P(83_0) + P(84_0) + P(85_0) + P(86_0) + P(87_0) + P(88_0) + P(89_0) + P(90_0) + P(91_0) + P(92_0) + P(93_0) + P(94_0)] \} - 1$$

These values for the trend are input to Prevdata. The whole process is repeated for the following years, until the latest date that data are available for, always using the same initial age groups as they age by one year. Consequently the trend for the youngest age group as it ages from year Y(1) to year Y(2) will be:

$$T_2(2) = [(5 * X_1(2) - P(A_1)) / (P(A_1) + P(B_1) + P(C_1) + P(D_1))] - 1$$

or

$$T_2(2) = [(5 * P_1(2) - P(A_1)) / (P(A_1) + P(B_1) + P(C_1) + P(D_1))] - 1$$

and so on.

6.3.2 An Alternative Method of Calculation

The technique described in section 6.3.1 can only be used if the data on prevalence have used the same age groups over the years, and these are the same age groups as used in the model's base year. This was not the case for the England & Wales data on smoking used with a 1991 model. Therefore, an alternative method had to be devised.

Age Bands	Risk Factor Category Prevalence							
	P(H ₀)	X(H ₁)	X(H ₂)	P(H ₃)	X(H ₄)	X(H ₅)	P(H ₆)	P(H ₇)
H	P(H ₀)	X(H ₁)	X(H ₂)	P(H ₃)	X(H ₄)	X(H ₅)	P(H ₆)	P(H ₇)
G	P(G ₀)	X(G ₁)	X(G ₂)	P(G ₃)	X(G ₄)	X(G ₅)	P(G ₆)	P(G ₇)
F	P(F ₀)	X(F ₁)	X(F ₂)	P(F ₃)	X(F ₄)	X(F ₅)	P(F ₆)	P(F ₇)
F to J	P ₂ (0)	X ₂ (1)	X ₂ (2)	X ₂ (3)	X ₂ (4)	X ₂ (5)	P ₂ (6)	X ₂ (7)
Trend		T ₂ (1)	T ₂ (2)	T ₂ (3)	T ₂ (4)	T ₂ (5)	T ₂ (6)	T ₂ (7)
E	P(E ₀)	X(E ₁)	X(E ₂)	P(E ₃)	X(E ₄)	X(E ₅)	P(E ₆)	P(E ₇)
D	P(D ₀)	X(D ₁)	X(D ₂)	P(D ₃)	X(D ₄)	X(D ₅)	P(D ₆)	P(D ₇)
C	P(C ₀)	X(C ₁)	X(C ₂)	X(C ₃)	X(C ₄)	X(C ₅)	P(C ₆)	X(C ₇)
B	P(B ₀)	X(B ₁)	X(B ₂)	X(B ₃)	X(B ₄)	X(B ₅)	P(B ₆)	X(B ₇)
A	P(A ₀)	X(A ₁)	X(A ₂)	X(A ₃)	X(A ₄)	X(A ₅)	P(A ₆)	X(A ₇)
A to E	P ₁ (0)	X ₁ (1)	X ₁ (2)	X ₁ (3)	X ₁ (4)	X ₁ (5)	P ₁ (6)	X ₁ (7)
Trend		T ₁ (1)	T ₁ (2)	T ₁ (3)	T ₁ (4)	T ₁ (5)	T ₁ (6)	T ₁ (7)
Year	Y(0)	Y(1)	Y(2)	Y(3)	Y(4)	Y(5)	Y(6)	Y(7)

Table 6.2 – Risk factor prevalence and trends over time by age and age group, with differing age groups.

In this case years Y(0) and Y(6) are the only years with prevalence data for the age groups that match the model's base year (A to E, F to J and so on), while years Y(3) and Y(7) have prevalence data relating to different age groups (D to H, I to R and so on), and years Y(1), Y(2), Y(4) and Y(5) have no prevalence data, (see Table 6.2).

As before, starting with year Y(0) one assumes that the prevalence of a risk factor category for an age group is distributed evenly across each one year age band.

Using:

$$P_1(0) = (P(A_0) + P(B_0) + P(C_0) + P(D_0) + P(E_0)) / 5$$

therefore:

$$P_1(0) = P(A_0) = P(B_0) = P(C_0) = P(D_0) = P(E_0)$$

This assumption is also applied to the other age groups for which prevalence data is available in years Y(3), Y(6) and Y(7). Therefore:

$$P_{D \text{ to } H}(3) = (P(D_3) + P(E_3) + P(F_3) + P(G_3) + P(H_3)) / 5$$

$$P_{D \text{ to } H}(3) = P(D_3) = P(E_3) = P(F_3) = P(G_3) = P(H_3)$$

and

$$P_1(6) = (P(A_6) + P(B_6) + P(C_6) + P(D_6) + P(E_6)) / 5$$

$$P_1(6) = P(A_6) = P(B_6) = P(C_6) = P(D_6) = P(E_6)$$

and so on.

Then one assumes that the prevalence of the youngest cohort X(A₁) in year Y(1) has the same prevalence as the youngest cohort P(A₀) in the previous year Y(0), and so on for the next years. Therefore:

$$X(A_1) = X(A_2) = X(A_3) = X(A_4) = X(A_5) = P(A_0)$$

and

$$X(A_7) = P(A_6)$$

Next the missing one year age banding prevalence can be calculated by interpolating diagonally across the cells, assuming a linear relationship between the prevalences of a single age band as it ages. Therefore:

$$X(B_1) = P(A_0) + [P(A_0) - P(D_3)] / 3$$

$$X(C_2) = P(A_0) + 2*[(P(A_0) - P(D_3)) / 3]$$

and so on.

6.3.3 Age Group Specific Risk Factor Trends

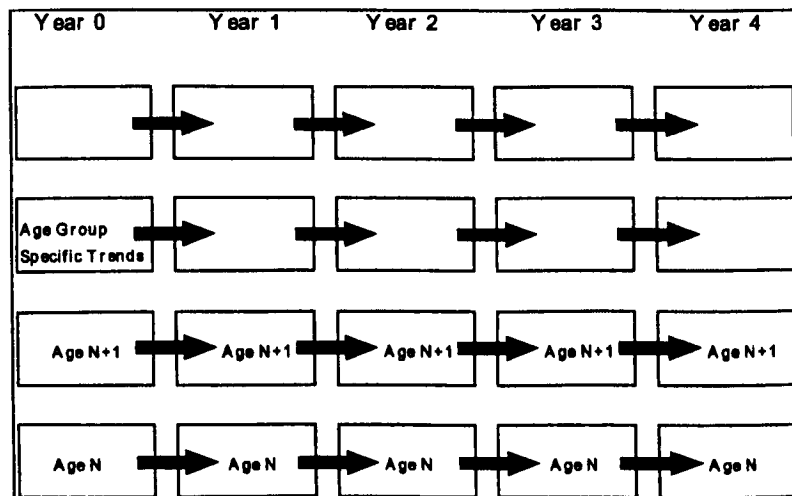

Figure 6.3 – Ageing of a cohort with age groups specific risk factor trends

If the risk factor is age group specific rather than cohort specific the missing one year age banding prevalences should be calculated by interpolating horizontally across the cells, again assuming a linear relationship between the prevalences of a single age band as it ages, see Figure 6.3. Therefore:

$$X(A_1) = P(A_0) + [P(A_0) - P(A_6)] / 6$$

$$X(D_1) = P(D_0) + [P(D_0) - P(D_3)] / 3$$

$$X(D_2) = P(D_0) + 2*([P(D_0) - P(D_3)] / 3)$$

and so on.

Consequently, having interpolated the prevalences for the one year age band, the prevalence for the age groups can be calculated:

$$X_1(1) = X(A_1) + X(B_1) + X(C_1) + X(D_1) + X(E_1)$$

Finally the age group trend for each year can be calculated:

$$T_1(1) = [(X(B_1) + X(C_1) + X(D_1) + X(E_1) + X(F_1)) - P(0_1)] / P(0_1)$$

$$T_1(2) = [(X(B_2) + X(C_2) + X(D_2) + X(E_2) + X(F_2)) - X_1(1)] / X_1(1), \text{ and so on.}$$

6.3.4 Future Trends

Only default future trends need to be input to Prevent to begin with since future trends can be specified during each run. However, the method for calculating these trends for input to Prevdata is the same. Future trends are required for at least the time period the simulation will be run for (the maximum being 50 years).

The techniques described for calculating past trends can be used for their calculation. One only needs to make an assumption of what the prevalences will be in the year Base Year + Simulation Period, and to then interpolate from the last year in which prevalence data are available. This interpolation will be carried out diagonally or horizontally depending on whether the risk factor is cohort or age group specific.

Ideally one would set up a number of trend files for each risk factor, with each file pertaining to a different assumption concerning future trend development.

6.4 Spreadsheet Implementation

As a result of this work I produced a test set of spreadsheets using the first method described, which allowed the user to enter the age group risk factor prevalence for one exposure category and then calculated the trends for input into Prevent. This was then

expanded by Dr van de Mheen to calculate smoking trends using three exposure categories, which I subsequently adapted to allow for the input of the future trends.

6.5 Discussion of Trends

During the development of these trend calculations it was suggested by Prof. Gunning-Schepers and Dr Barendregt, to avoid confusion, that Prevent should only be used in the cohort mode, and that any age groups trends should be specified by translating its effect to the birth cohorts.

This work on trends succeeded in clarifying the methods for defining and calculating the trends input data file for Prevent, as well as giving the developers an opportunity to fully explain the mechanisms by which they are used within the model. Also documenting this work has meant that the principles of calculated trends can be understood and implemented by others, as demonstrated by Dr van de Mheen.

The main draw back with using trends as required by Prevent concerns the availability of risk factor prevalence data. Prevent requires risk factor prevalence data for LAT+LAG years before the base year, which in the case of cigarette smoking linked to lung cancer and COLD is 20 years, and 30 years in the updated version of Prevent (see Chapter 10). Fortunately I had access to the raw General Household Survey (ONS 1998) data sets from 1973 onwards (see Chapter 4), which allowed me to extract the data in the appropriate form. Even so data were not available for all years, and I had to interpolate between years with data to estimate prevalences in missing years. However, had I had to rely on published data I would have found that over time different age group and exposure categories had been used, and this has been the case for other researchers (Biomed II 1999). In addition, as the time periods that data are require for increase, one finds such data are not available. Blood pressure and cholesterol data are only available at a population level for England since the Health Survey for England 1991 (White 1993). This means that researchers will increasingly have to interpolate from available data, rather than using actual data, which is not ideal. Other methods need to be explored for calculating mortality based on available data, such as the

method of Peto et al (Peto 1992) for estimating national mortality from tobacco from disease mortality statistics.

PART II

6.6 PREVENT Limitations

In the course of using the Prevent model I became aware of several limitations of the model. These have particular consequences in that the model is not able to simulate certain types of interventions that policymakers may be interested in. These limitations were not made explicit in the literature on Prevent.

6.6.1 Shifting Risk Factor Exposure

One of most serious limitations of Prevent is that it was not designed to model the effect of interventions which move members of one risk factor exposure group into a number of different exposure groups. For example, it was designed for modelling movement from an exposed to a ex-exposed category, such as heavy or moderate smokers becoming ex-smokers, and not for modelling heavy smokers becoming moderate or light smokers. This means that it is impossible to shift the risk factor distribution, to simulate a population intervention, such as the result of a national campaign to reduce individuals' cholesterol.

This limitation of Prevent is important since preventive strategies may have only small effects on the risk experienced by an average individual, but may have large benefits at a community or population level. For instance, one person who loses some excess weight may only experience a small impact on their personal risk of disease, but if many people in a population lose a little excess weight; this may have a substantial impact on the population's experience of obesity related disease. This is the so-called prevention paradox, where if a large number of people each reduce their risk slightly, the entire population may experience a substantial reduction in disease burden (Rose 1992).

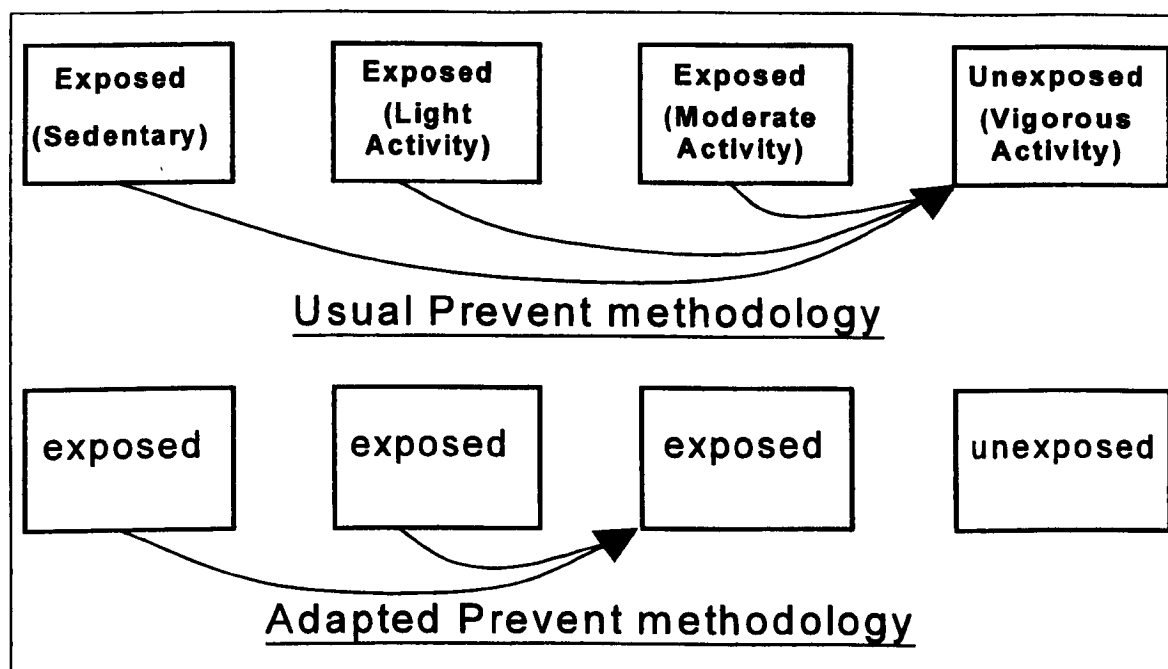

Figure 6.4 – Movement between exposure categories under Prevent's original and adapted methodologies

I partially solved the problem of not being able to move individuals to another lower risk factor exposure by setting up the model so that one of the exposure categories, for example moderate physical activity, was treated as the non-exposure category, with the remnant risk of the this new non-exposed category set to the value for the actual exposed category, and by giving all the individuals already in this category, before the intervention, this same remnant relative risk rather than giving them a relative risk equal 1.0 of the true non-exposed category, see Figure 6.4.

The work I did with Prevent modelling physical activity targets entailed either increasing the prevalence of those people taking moderate physical activity, or increasing the prevalence of those people taking vigorous physical activity. Since each intervention only involved moving individuals from one exposure group to another exposure group; the interventions could be modelled by treating the exposure group that individuals move to as an ex-exposure group, although it meant setting up separate models for each scenario. A detailed description of this work is given in Chapter 7 - Modelling the Effects of Increased Physical Activity Using The PREVENT Model.

However, this method can only be used when the intervention entails moving individuals to one category, be it an exposed or non-exposed category, since this conforms to Prevent's methodology. It is impossible shift exposure levels, for example

with a physical activity intervention it would not be possible to move individuals who are sedentary to being lightly active, individuals who are lightly active to being moderately active, and individuals who are moderately active to being vigorously active; it is only possible to move people who are sedentary, lightly active, or moderately active to being vigorously active.

6.6.2 Relative Risks Less Than One

Prevent was originally designed in terms of modelling the effect of risk factors which have a dose response relationship between level of exposure and risk of disease specific death. Using this reasoning the non-exposed group was always used as the reference group with a relative risk of 1.0, hence the exposed groups would have relative risks greater than 1.0. However, this is not true for all variables which might be of interest to health policymakers. For example, moderate alcohol has been argued to be protective of CHD (Marmot 1981 and Klatsky 1981), while for the other alcohol related disease such as cirrhosis, accidental falls and traffic accidents (Corrao 1999), which are within Prevent, a dose-response relationship between alcohol intake and disease has been described.

Alcohol Exposure Categories	Relative Risk of Disease Mortality			
	CHD	Cirrhosis	Accidental Falls	Traffic Accidents
Abstainers/Light Drinkers	2.0	1.0	1.0	1.0
Moderate Drinkers	1.0	1.0	1.0	1.0
Heavy Drinkers	2.0	9.0	2.0	2.0

Table 6.3 – Relative risks of disease mortality for alcohol as used by Prevent (Gunning-Schepers 1989).

Due to the methodology of Prevent and the U-shaped risk relationship between CHD mortality and alcohol intake the model was originally set up with moderate alcohol intake being the non-exposed category with a relative risk of 1.0 for CHD mortality, and this meant that the relative risks for cirrhosis, accidental falls and traffic accident mortality for moderate alcohol intake were also set to 1.0, which is an underestimation of the true relative risks. It would be more realistic to set the relative risks for all diseases for abstainers/light drinkers to 1.0, and having increased relative risks for cirrhosis, accidental falls and traffic accident mortality for moderate alcohol intake,

while for CHD mortality the relative risk for moderate alcohol intake is set to a value less than 1.0.

Unfortunately the Prevddata data input programme was designed by the developer not to allow the user to input relative risks less than 1.0 into the model. I discussed this matter several times with Dr Barendregt. Initially he was reluctant to say whether Prevent could accommodate relative risks less than 1.0 since he had never tried it and was unsure what the model would do. However, he finally decided that it would be possible to input relative risks less than 1.0 into Prevent, although it would have to be done by editing the relative data files directly rather than using Prevddata. Dr Barendregt felt that Prevent should be able to cope with such relative risks as long as they were not close to zero, since Prevent uses a linear reduction in relative risks to the remnant relative risk, but close to zero the reduction is mostly likely as in Figure 6.5.

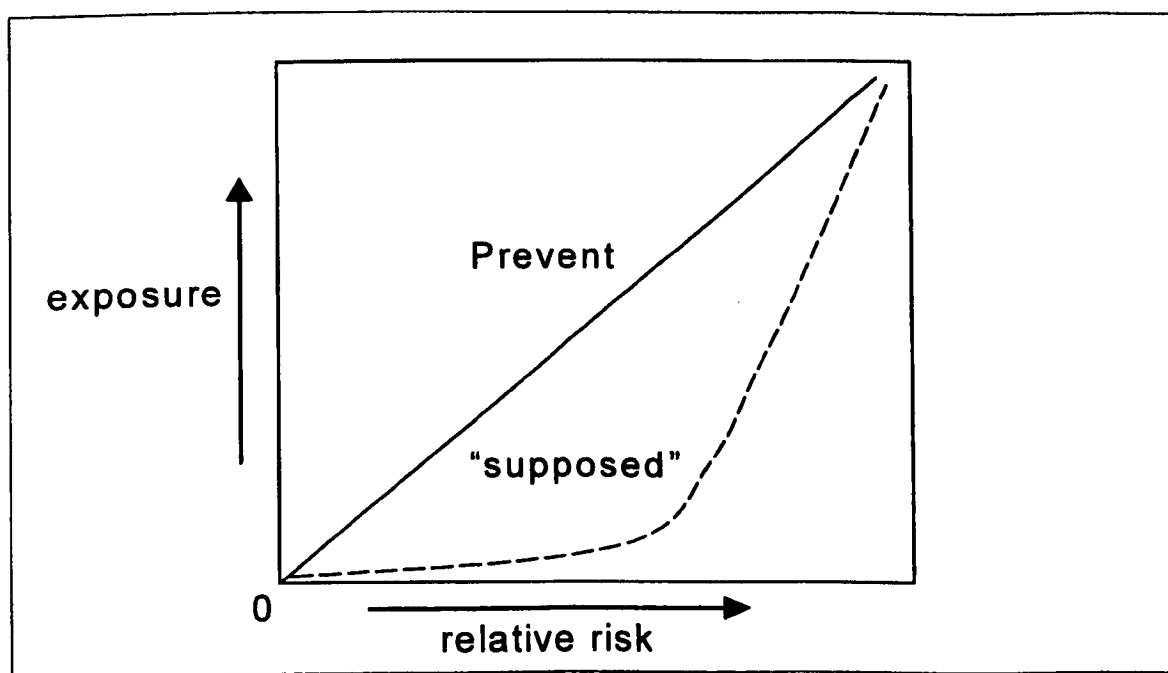

Figure 6.5 – Relative risk close to zero

The time it took to solve these problems was considerable, and highlights how, when using a model developed by others, it can be quite hard to solve methodological problem or adapt the model if your policy question does not match, or are not perceived as important by the developers. This type of problem could not have been foreseen until real policy questions were discussed. When different groups have different policy

agendas they are trying to address, which do not match the developers' interests they may be given a lower priority, and this may slow the modelling process.

6.6.3 Univariate Risk Factor Distributions

Prevent uses independent risk factor distributions, where, within the model, the prevalence of risk factors are input and used separately. While it can hold prevalence data for smoking, hypertension and hypercholesterolaemia individually, it does not hold the data for the prevalence of these risk factors in combination. That is, no allowance can be made for the clustering of risk factors in individuals when simulating interventions. This limitation is of particular concern since it has been shown that clustering of cardiovascular risk factors is strongest in those individuals with the highest level of these risk factors (Criqui 1980).

A paper by van de Mheen et al (van de Mheen 1997) attempted to estimate the maximum extent of bias in outcome measures of Prevent if an independent risk factor prevalence was wrongly assumed. The mortality experiences of a cohort of Dutch men aged from 0 to 95 years of age were compared based on the assumptions of independent and completely dependent risk factor prevalences, for the risk factors hypertension, hypercholesterolaemia and smoking. The researchers concluded that assuming independence of risk factor prevalence within Prevent did not greatly affect its estimates of life expectancy and potential years of life gained. However, this paper did not address the problem that one is unable to identify those sections of the population with combinations of risks factors when using Prevent, and hence one is unable to model the effect of targeting interventions at these sections specifically.

This is another important limitation with regard to using Prevent to inform policy, since questions are often asked regarding whether health resources should be targeted to those at most risk and who might benefit the most from an intervention, rather than using a population approach in which health resources are not targeted, but are used to change the overall population distributions of risk.

6.7 Discussion of Limitations

The limitations of the Prevent model are serious in terms of restricting its use as a policy tool, and will heavily influence one's decision as to whether or not to use the model, since there are a range of interventions that the model cannot simulate. I only became aware of these limitations after I had used the model for some time, and had tried to simulate interventions suggested by policymakers and other researchers. This highlights how it is only by using a model to simulate real interventions that one can fully understand its capabilities, since the model's documentation may only outline interventions that can be simulated with it, which may not be relevant to current policy. This also emphasises the importance of developing such models in conjunction with policymakers, since they may have more insight than researchers as to what are the important policy issues that need to be addressed.

In the following chapters I discuss how I have used the Prevent model with policymakers, and how I have managed to overcome some of the limitations of the model, as well as how these limitations restrict Prevent's use as a policy tool.

6.8 Summary

The first part of this chapter describes my early work on the Prevent risk factor trends model, since this was considered a problematic area, partly due to a lack of documentation concerning what data needed to be input into Prevdta, and partly due to it being unclear how these data are input. My work involved calculating the trend inflow and outflow values, and producing spreadsheets to aid with the creation and input of the Prevent trend files.

The second part of this chapter details how, through my work with Prevent, I identified some of the limitations of the model when trying to simulate risk factor interventions for policymakers. It outlines how I was able to overcome some of these problems, and explains why some problems could not be solved due to the methodology of the model and due to the developers resistance to adapting the model. In addition, I discuss how these limitation restrict Prevent's use as a policy tool.

Chapter 7 - Modelling the Effects of Increased Physical Activity Using The PREVENT Model

7.1 Introduction

I began to work on modelling physical activity when there was a great deal of discussion going on about the setting of targets for physical activity (HEA 1994), as well as being a time when the number of Prescription for Exercise Schemes, in which general practice patients are given free or reduced entrance to exercise facilities, were growing rapidly.

The previous Government's White Paper "*The Health of the Nation*" (HMSO 1992) introduced targets for the reduction in the death rates for coronary heart disease, taking their lead from WHO's "*Health For All by the Year 2000*" (WHO 1985), see Chapter 3 – Health Policy for more details. In keeping with this enthusiasm for targets the HEA proposed a set of physical activity targets, however it was not clear how the promotion of physical activity could most effectively contribute to the Health of the Nation targets. To contribute to the debate I modelled the effects of increasing activity in the population, looking at the effects of targeting different exercise levels, age and gender groups. This work was undertaken at the request of, and in collaboration with, the Health Education Authority.

7.2 Health Benefits of Physical Activity

Physical activity, as defined in the report of the Surgeon General on physical activity and health (US Department of Health And Human Services 1996), is "*bodily movement produced by the contraction of skeletal muscle that increases energy expenditure above the basal level*". The report concluded that physical activity was beneficial in terms of the following health outcomes:

- Overall Mortality - Higher levels of regular physical activity are associated with lower mortality rates for all adults, with even those who are moderately active on a regular basis having lower mortality rates than those who are sedentary.

- **Cardiovascular Diseases** - Regular physical activity decreases the risk of cardiovascular disease mortality in general and of coronary heart disease (CHD) mortality in particular. However, existing data are not conclusive regarding a relationship between physical activity and stroke.
- **Blood Pressure** - Regular physical activity prevents or delays the development of high blood pressure, and exercise reduces blood pressure in people with hypertension.
- **Non-Insulin-Dependent Diabetes Mellitus** - Regular physical activity lowers the risk of developing non-insulin-dependent diabetes mellitus.
- **Obesity** - Low levels of activity, resulting in fewer kilo-calories used than consumed, contribute to the high prevalence of obesity in the United States. Also physical activity may favourably affect body fat distribution.

In addition, the report concluded that physical activity was associated with reduced levels of colon cancer, osteoarthritis, osteoporosis, falling and depression, as well as improving health related quality of life. However, this chapter will concentrate on the effect of physical activity on CHD with respect to its inclusion as a risk factor within the Prevent model.

Lack of physical activity has been shown to be a strong independent risk factor for death from CHD (Powell 1987). In a meta-analysis, Berlin and Colditz (Berlin 1990) calculated a 1.9 fold increased relative risk for CHD mortality associated with a sedentary, as compared with a vigorously active, lifestyle. This meta-analysis is discussed in more detail in section 7.6.1. Population surveys have shown that a small percentage of the British population take enough exercise to protect against CHD (Sports Council 1992). Inactivity, then, may be an important cause of CHD mortality.

7.2.1 Measurement of Physical Activity

Physical activity is a complex and difficult to accurately measure set of behaviours, with studies using numerous approaches such as self-reported surveys, job classification, behavioural observation, motion sensors and physiologic markers to quantify physical activity levels of individuals. Since physical activity is a continuous variable, and across several dimensions such as intensity, frequency, or type (Powell 1994); studies may define and report levels of activity differently. This is an important issue to consider since the strength of the relationship between physical activity and CHD will be highly dependent on the effectiveness, in terms of accuracy and reliability, of the measurements used in studies (Haskell 1995). Physical activity is thought to be a blunt proxy for physical fitness; a more effective measure for demonstrating the relationship with CHD (Morris 1996). However, physical fitness was only measured in 31% of our population surveys (Fentem 1994), and so would not be representative if applied to the whole population.

7.3 Current Activity Levels in the Population

Before I could develop a model of change in physical activity I first had to determine the current level of physical activity in the population. There were very few sources of data available. The principle source of information on physical activity in the England & Wales population were the Allied Dunbar National Fitness Survey (ADNFS) (Sports Council and Health Education Authority 1992) and the HEA's National Survey of Activity and Health (HEANSAH), which have been amalgamated by the HEA to increase the power of the analysis.

Unfortunately the levels of physical activity, for which the relative risk were given by Berlin and Colditz, were only defined as vigorous, moderate, light and sedentary, and did not correspond to those of the ADNFS, which divided physical activity into 6 levels. Therefore the ADNFS levels had to be re-analysed by the HEA to conform with the levels of vigorous, moderate, light and sedentary exercise.

Activity levels in the ADNFS were based on 20 minute periods of physical activity in a

four week period, and were re-analysed with the following definitions:

Vigorous - twelve or more occasions of activities at 7.5 kcal/minute and above, such as squash, running, football, swimming, tennis, aerobics and cycling, if out of breath or sweaty.

Moderate - twelve or more occasions of activities between 5 and 7.5 kcal/minute, such as football, swimming, tennis, aerobics and cycling, if not out of breath or sweaty, and table tennis, golf, social dancing and exercises, if out of breath or sweaty.

Light - one to eleven occasions of activities at 5 kcal/minute and above, such as table tennis, golf, social dancing and exercises, if not out of breath or sweaty, bowls, and fishing, darts and snooker.

Sedentary - no occasions of activities above 5 kcal/minute.

This was done for both 20 minute exercise periods at least three times a week and 30 minute exercise periods at least five times a week. Tables 7.1 and 7.2 show the aggregated ADNFS and HEANSAH prevalences of physical activity, which have been taken as those for the population, and the readjusted exercise levels.

MEN		Age Groups (%)					
Exercise Level	16-24	25-34	35-44	45-54	55-64	65+	
Vigorous	28.9	20.4	12.8	8.4	4.1	1.4	
Moderate	37.7	41.6	40.8	38.9	29.8	19.6	
Light	27.8	30.1	36.5	38.1	36.5	35.9	
Sedentary	5.6	7.9	9.9	14.6	29.6	43.1	
WOMEN		Age Groups (%)					
Exercise Level	16-24	25-34	35-44	45-54	55-64	65+	
Vigorous	9.7	7.6	4.1	2.9	1.8	0.2	
Moderate	37.1	46.5	46.0	37.3	31.8	19.5	
Light	44.5	39.4	40.0	46.3	45.3	40.3	
Sedentary	8.7	6.5	9.9	13.5	21.1	40.0	

Table 7.1 - Prevalence of physical activity (20 minutes at least 3 times a week) for England and Wales by sex and age group (Combined ADNFS and HEANSAH data re-analysed by the HEA)

MEN		Age Groups (%)				
Exercise Level	16-24	25-34	35-44	45-54	55-64	65+
Vigorous	10.6	6.5	4.2	1.4	0.4	0.0
Moderate	53.5	52.6	45.8	44.6	30.5	20.1
Light	28.9	32.0	39.0	38.0	37.1	35.9
Sedentary	7.0	8.9	11.0	16.0	32.0	44.0
WOMEN		Age Groups (%)				
Exercise Level	16-24	25-34	35-44	45-54	55-64	65+
Vigorous	2.9	2.8	0.5	0.4	0.4	0.0
Moderate	40.2	48.2	46.6	36.9	31.4	18.0
Light	46.0	41.0	42.0	47.8	45.1	39.9
Sedentary	10.9	8.0	10.9	14.9	23.1	42.1

Table 7.2 - Prevalence of physical activity (30 minutes at least 5 times a week) for England and Wales by sex and age group (Combined ADNFS and HEANSAH data re-analysed by the HEA)

Care needs to be taken in calculating the prevalence due to the different ways of measuring physical activity within and between studies, as mentioned in section 7.2.1.

7.4 Initial Physical Activity Targets

This work adopted, as its guidelines, the targets for physical activity proposed by the HEA in 1994, which were to be considered by the Task Force on Physical Activity in terms of their health effects and the policies needed to achieve them. These targets aimed to increase both the frequency and the intensity of people's physical activity. The targets were:

Target 1: 'To reduce by at least 50% the proportion of men and women aged 16 to 74 taking no occasion of moderate physical activity of at least 30 minutes, in the preceding four weeks, by 2005.'

Target 2: 'To increase the percentages of men and women aged 16 to 74 taking a minimum of 30 minutes of at least moderate physical activity on five days a week by at least 15% by 2005.'

Target 3: 'To increase the percentages of men and women aged 16 to 64 taking on average three periods of vigorous activity of 20 minutes duration a week by at least 9% by 2005.'

7.4.1 Threshold or Graded Effect of Physical Activity

In modelling the targets I tested two alternative hypotheses concerning the relationship between CHD risk and level of physical activity, since there was some debate as to which theory truly reflected the relationship:

- Graded effect - that there is an inverse relationship between CHD mortality risk and physical activity (Shaper 1991);
- Threshold effect - that only vigorous physical activity decreases CHD mortality risk (Morris 1990).

Many studies (Kannel 1986, Powell 1987 and Shaper 1991), including Berlin and Colditz’s meta-analysis, have shown a dose-response relationship between CHD mortality risk and level of physical activity, while the work of others (Morris 1990) seemed to show that only vigorous activity was beneficial in terms of reducing CHD mortality risk, so I decided to investigate the effect of the physical activity interventions under each hypothesis.

The relationships are illustrated in terms of the independent relative risks of CHD mortality by physical activity level in Table 7.3.

Hypothesis A		Hypothesis B	
Physical Activity Levels	Relative Risk	Physical Activity Levels	Relative Risk
Vigorous	1.0	Vigorous	1.0
Moderate	1.4	Moderate	1.5
Light	1.7*	Light	1.5
Sedentary	1.9	Sedentary	1.5

* from interpolation

Table 7.3 – Independent relative risks of CHD mortality using a threshold and a graded hypothesis.

7.5 Initial Exercise Interventions

The initial interventions that were modelled had been derived from the targets set by the Physical Activity Task Force. All the interventions were simulated using the graded effect

hypothesis, while those interventions that shift people into the vigorous exercise group were also simulated using the threshold hypothesis.

7.5.1 Initial Scenarios

Four initial scenarios were modelled:

- A. The three targets described in the section 7.4 would be applied evenly throughout the population.
- B. Achieving the targets by concentrating the changes only in the youngest age groups: Target 1 - 16 to 54, Target 2 - 16 to 34 and Target 3 - 16 to 34.
- C. Achieving the targets by concentrating the changes only in those people aged over 35.
- D. Achieving the targets by concentrating the changes only in the oldest age groups: Target 1 - 45 to 64, Target 2 - 45 to 64 and Target 3 - 55 to 64.

The age inconsistencies of interventions B and D are due to the structure of the population, since there were not enough people in some of the age groups to achieve the percentage changes that were defined in the targets set for the total population.

In simulating the Target 1 scenario the intervention increased the level of physical activity of the sedentary group to the level of the moderate group. The Target 2 scenario was first simulated with an intervention which increased the physical activity of the least active, i.e. the sedentary exercisers, and was next simulated with an intervention which increased the physical activity of the most active, but were not vigorously active, i.e. the moderate exercisers. These two separate model runs were used to provide lower and upper limits for the effectiveness of the intervention. The Target 3 scenario was first simulated with an intervention which increased the physical activity of the least active, i.e. the sedentary and light exercisers, and was then simulated with an intervention which increased the physical

activity of the moderately active, i.e. the moderate and light exercisers, again modelled separately to provide lower and upper limits for the effectiveness of the intervention.

7.6 Adapting PREVENT

I used my 1991 English & Wales version of Prevent model to simulate the proposed changes in physical activity levels for the population, modelling the outcomes using the two hypotheses and the strategies described previously. Prevent does not normally include lack of physical activity as a risk factor, therefore the following data were input for the England and Wales population:

- physical activity level categories: sedentary, light, moderate and vigorous;
- prevalence of physical activity by sex, age groups and activity level, using the data from the combined ADNFS and HEANSAH data re-analysed by the HEA as described above;
- relative risk of CHD death due to lack of physical activity by sex, age groups and activity level adapting the relative risk estimates of Berlin and Colditz and Morris described above,
- two time intervals, the first, LAT, giving the time between taking up physical activity and a person's relative risk begins to decrease, and the second, LAG, giving the time between a person's relative risk beginning to decrease and when it reaches its lowest value for the new level of physical activity,
- the remnant relative risk, which is the lowest possible relative risk that an ex-exposed person has after LAT+LAG time has elapsed on taking up a new increased level of physical activity.

LAT and LAG were set to zero and one, the minimum values possible, respectively, since

I decided after discussions with Professor Jerry Morris that an individual would experience the benefits of increased physical activity within a year. Also as a result of my discussions I decided that there would be no excess remnant risk LAT+LAG years after taking up a new increased level of physical activity, and that the remnant risk would be the same as the actual relative risk for the level of physical activity.

The main limitation was that Prevent was not designed to calculate the effect of members of one risk factor exposure group moving into a number of different exposure groups; it was designed solely for modelling movement from an exposed to a non-exposed category. For instance, with Prevent changing heavy or light smokers to ex-smokers is possible, but changing heavy smokers to light smokers is not. This means that it is impossible to shift the risk factor distribution, as would be the effect of a population intervention, such as a result of a national campaign to reduce individuals' blood cholesterol or increase exercise levels.

I solved the problem of not being able to move individuals to another lower risk factor exposures by first creating two versions of the England and Wales Prevent. The first version conformed to the methodology of Prevent with individuals moving from any exposure category to the non-exposure category, vigorous physical activity. The second version was set up with individuals being able to move from any risk factor category to the category of moderate physical activity. I achieved this by setting up the model as if the category of moderate physical activity was the non-exposure category, with the remnant risk of the category set to the actual value for moderate physical activity, and by giving all the individuals already in that category, before the intervention, the same remnant relative risk rather than having a relative risk of one. I also consulted the developers of Prevent, Professor Gunning-Schepers and Dr Jan Barendregt, to check that this would not interfere with the model's other processes, and they thought that this could be achieved without any problems. Fuller details of this adaptation are given in Chapter 6.

7.6.1 Adapting the Relative Risks Estimates

The relative risks for CHD mortality due to lack of physical activity were taken from a

comprehensive meta-analysis (Berlin 1990). The meta-analysis reviewed 27 studies, with respect to the quality of the study as measured by Powell et al (Powell 1987), in terms of independent relative risk by activity level of the following outcomes:

- CHD;
- CHD death;
- Myocardial infarction (MI);
- MI plus sudden death;
- Angina pectoris.

Relative risks were produced separately for these events from the studies identified by Powell et al of occupational and non-occupational activity, then they were recalculated including recent non-occupational studies not included in the original review by Powell et al. In addition, the relative risks for occupational studies by quality of study were produced, using Powell et al's scoring system based on the quality of the measurement of activity, the measurement of disease status and the epidemiological method. The relative risks were calculated in terms of the following comparisons:

- I. High activity compared with moderate activity groups from studies that reported both moderate and sedentary comparison groups;
- II. High activity compared with low activity groups from studies that did not separate moderate and sedentary comparison groups;
- III. High activity compared with sedentary groups from studies that reported both moderate and sedentary comparison groups.

In terms of representing the dose response relationship between physical activity within the Prevent model the relative risks of interest are those of comparisons I and III, with some interpolation needed to derive the relative risk for high activity compared with light activity.

On closer inspection of the relative risk by occupational and non-occupational studies, as reviewed by Powell et al, one finds few studies that calculate the relative risks for MI, MI plus sudden death or angina pectoris, see Table 7.4. For CHD and CHD death there were more occupational activity studies than non-occupational activity studies reporting the associated relative risks. When those studies not originally reviewed by Powell et al are included the number of studies of non-occupational activity increases slightly to one study reporting CHD and 4 studies reporting CHD death relative risks. For occupational studies that were scored according to Powell et al's method for quality; CHD and CHD death relative risks were derived from only 2 studies for each of the outcomes that were considered satisfactory.

Outcome	Type of Study	
	Occupational Activity	Non-Occupational Activity
CHD	4	0
CHD death	5	1
Myocardial infarction	1	2
MI plus sudden death	1	0
Angina pectoris	1	0

Table 7.4 – Number of studies reporting CHD outcomes by type of activity, as reported by Powell et al.

Table 7.5 summarises the relative risks produced by Berlin and Colditz for CHD and CHD death for sedentary and moderate activity compared to high activity by their four divisions of type of study.

Type of Study	Sedentary		Moderate Activity	
	CHD	CHD death	CHD	CHD death
Non-occupational	-	1.6 (1.2-2.2)	-	1.3 (1.0-1.7)
All Non-occupational	0.7 (0.3-1.9)	1.7 (1.2-2.3)	0.9 (0.4-2.0)	1.1 (1.0-1.3)
Occupational	1.4 (1.0-1.8)	1.9 (1.6-2.2)	1.1 (0.9-1.3)	1.4 (1.2-1.8)
Satisfactory Occupational	1.9 (1.0-3.6)	1.8 (1.5-2.3)	1.3 (0.7-1.3)	1.6 (1.2-2.1)

Table 7.5 – Summary of relative risks with 95% CI by type of study and level of activity compared to high activity for CHD and CHD death.

In terms of CHD the relative risks do not show clear evidence of a reduction in risk due to increased physical activity, whereas there is a stronger association for CHD death with a relative risk of around 1.8 associated with a sedentary lifestyle compared to a vigorously active lifestyle, with this risk increasing or decreasing depending on the type of studies used.

There were several problems in using the relative risks of Berlin and Colditz. One problem is that there is no mention of how their different levels of physical activity are defined, which is a multifaceted issue since it is dependent on intensity, duration and frequency of activity. Therefore I had to assume that these levels were similar to those used in the ADNFS data, which was not ideal. The only alternative would have been to have used the relative risks from just one study, such as the Harvard alumni study (Paffenbarger 1984), which is a large well designed study, but limited in that the relative risk are for a population of white American college educated men, which may not be appropriate for applying to the whole England & Wales population. The Berlin and Colditz relative risks used were similar to those produced by Powell et al, see Table 7.6, so I had some confidence in using them.

Exposure Groups	Relative Risk
Sedentary	2.0
Irregular	1.5
Regular	1.1
Vigorous	1.0

Table 7.6 – Relative risk of CHD mortality from Powell et al(1987).

No relative risk for light activity was produced in the meta-analysis, so I derived a hypothetical relative risk by linear interpolation. As the Task Force had not specified whether the physical activity targets set by were to be achieved through increases in occupational or non-occupational physical activity; I chose to use the relative risks from occupational studies due to their being based on the largest number of studies. The relative risks used are shown in Table 7.3.

In addition, these relative risks, as well as those used for the threshold effect hypothesis, were not calculated separately by age or sex. There are differences in relative risks by age and sex for the other risk factors in Prevent (Gunning-Schepers 1989) and it seems probable that relative risks associated with physical activity would also vary by age and sex. This emphasises how one can only do modelling based on current knowledge, and how one important aspect of modelling is that it highlights areas where research is lacking.

7.7 Limitations Of PREVENT

The problems of "fitting" available prevalence and relative risk data to the England & Wales population, and then tailoring these for input into Prevent were considerable and entailed making compromises.

The main limitation was that Prevent was not designed to calculate the effect of members of one risk factor exposure group moving into a number of different exposure groups; it was designed solely for modelling movement from exposed categories to a non-exposed category.

This is an important issue since preventive strategies at a community or population level which involve harm minimisation, i.e. moving the population to a lower level of risk behaviour rather than the "ideal" least risk behaviour. So in the case of physical activity it would be more realistic to expect individuals in the population to increase their levels of activity by varying amounts, such as sedentary to moderate, light to moderate, or light to vigorous, rather than the whole population becoming vigorously active.

As Prevent uses the independent risk factor distributions, rather than a multi-variate risk distribution, one cannot reduce the prevalence levels of other risk factors that may be affected by increased physical activity for the sections of the population that have increased their physical activity levels. Only by using a multi-variate risk factor distributions would it be possible to identify these sections of the population.

An additional problem was that only age group divisions beginning with multiples of five are permitted, so the youngest age to be intervened upon had to be aged 15, rather than 16 years. However, this should not have made much of an impact on the effect of the interventions since the CHD death rates are very low at these younger ages, and so changes in physical activity will have little effect in terms of CHD mortality in comparison with older ages groups, as demonstrated later with the modelling.

7.8 Model Assumptions

In setting up Prevent the modeller must set certain calculation options and variables, and these translate into a number of assumptions about the way in which an intervention would affect physical activity in the population, and the process by which physical activity influences CHD mortality.

The assumption was made that the intervention started in 1994 and continued for the next eleven years, with the target prevalences of the strategies being achieved in 2005, a target year for *The Health of the Nation* (HMSO 1992). The population was simulated for a further fourteen years after the end of the intervention, during which time it was assumed that the prevalence of physical activity amongst age groups remained at their new increased levels.

The mechanism by which physical activity affects CHD mortality is described by the time periods over which a person's risk decreases, the LAT and LAG times, and the level of risk it declines to, the remnant relative risk. Within the model it was assumed that, on increasing their level of physical activity, a person's relative risk begins to decrease immediately, and that one year after taking up a new level of physical activity a person's relative risk decreases to that of people exercising at that level. Some sensitivity analyses were performed by increasing these time periods when running the model, but the effect of this was only to delay the health gain of the interventions by the increased time period.

In terms of the remnant risk it was assumed that a person's previously less active lifestyle will not continue to have a detrimental effect on their health, and that they will take on the relative risk attributed to their current physical activity level.

As the main interest was to investigate how changing a population's physical activity levels might affect its CHD mortality it was decided to assume that physical activity only decreased the risk of CHD death and that it did not affect the other diseases mentioned in the introduction. In addition, I assumed that physical activity did not affect the other risk factors that Prevent includes, such as hypertension, cholesterol and obesity, since the

independent risk factor distributions within Prevent mean that one cannot reduce the prevalence levels of these risk factors for the sections of the population that have increased their physical activity levels. These assumptions that limited the influence of physical activity on health meant that the results of the model would have underestimated the true effect of the intervention, and needs to be considered when interpreting the results.

Care needs to be taken in choosing either the age group or the cohort option for the calculations in Prevent, since the two options can give markedly different results. The age group option should be used when considering a risk factor that is predominately age dependent, such as hypertension. An intervention that causes a behavioural change, such as cigarette smoking cessation, is more likely to affect a birth cohort which retains the change as it ages. I chose to model physical activity as having an age group effect, although I also tested the model with the cohort option to see how this affected the results.

Under the age group option it was assumed that the proposed intervention would change the prevalence of physical activity for specific age groups for the entire simulation period of 25 years, so that as cohorts aged over time they would take on the prevalence of the corresponding age groups when they entered them. For instance, taking the 28.9% prevalence of vigorous physical activity for 16 to 24 year old men from Table 7.1, after ten years using the cohort option, when these men are 24 to 34, their prevalence of vigorous activity would still be 28.9%, that is, the cohort would retain its prevalence from the previous age group. Under the age group option after ten years this initial cohort will have a prevalence of vigorous activity of 20.4%, as it will acquire the prevalence of the previous cohort in the 25 to 34 year age group.

It was assumed that any changes in the prevalence of physical activity within the population would be solely as a result of the interventions, and that there would be no background risk factor trends in the population, that is, without an intervention there would be no change over time in rates of physical activity.

7.9 Initial Intervention Outputs

I produced the output of the model in terms of the effect of the simulated interventions on CHD mortality rate per 1000 per year, total mortality reduction and actual years of life gained.

7.10 Initial Results

7.10.1 Threshold Versus Graded Effect

Under the graded effect hypothesis all three targets achieved reductions in mortality. Under the threshold effect hypothesis only Target 3, increasing the proportion taking vigorous exercise, had any effect.

A review of physical activity and fitness studies (Blair 1996) investigated the question of whether there was a threshold or a graded effect of physical activity on reducing the risk of morbidity and mortality, and concluded that the weight of available evidence showed an inverse gradient of risk of clinical disease across strata of physical activity. In addition, having talked with Professor Morris and Dr Melvyn Hillsdon, at the London School of Hygiene and Tropical Medicine, it became apparent that the different findings of a threshold or graded effect may have been due to different definitions of physical activity levels, with some of Morris et al's vigorous activities being classed as moderate by other studies, such as brisk walking, stair climbing, regular cycling and swimming (Morris 1996). The majority of studies demonstrated a graded effect and I decided to proceed with the modelling using this hypothesis. The remainder of these results are based on the assumption that the graded effect hypothesis holds.

7.10.2 Reduction in CHD Death Rate

There was a small reduction in the death rate from coronary heart disease associated with the achievement of each of the three targets in men and women. This represented a fall of between 0.1% and 0.4% in men, and 0.04% and 0.13% in women. Assuming that all three

targets were achieved there might be a reduction of a little less than 1% in the CHD death rate in men, and a smaller reduction in women. Targets 1 and 2, which affected many more people, but involved lower levels of exercise, showed a much greater potential for reductions in CHD mortality.

In the case of Targets 2 and 3, which involved increasing activity to moderate or vigorous levels, the size of the reduction achieved was influenced by whether the people who achieved the increased exercise level were drawn from those already taking some exercise, lightly or moderately active, or from those who were sedentary, least active. The greatest effect would be achieved by moving the sedentary people into the moderate or vigorous categories, but, in reality, it is more likely that those already taking some exercise would move into the next highest exercise category. This was therefore the assumption used in the rest of this initial modelling.

7.10.3 Reduction in Total Mortality and Life Years Gained

While the proportional reduction in the death rate appeared disappointing, the actual number of deaths under age 65 postponed each year was not insubstantial. The variations in the numbers of deaths postponed were a reflection of the expected variation in the size and age structure of the population. In general, achieving Target 1 could be expected to postpone the deaths of around 1700 people a year, achieving Target 2 would result in a slightly smaller number of deaths postponed, while achieving Target 3 would be expected to postpone only around 600 or less deaths a year. Overall achieving the targets in men would result in a much greater saving in life years than for women.

7.10.4 Age Groups

To examine the differing effect of targeting exercise interventions at differing age groups, the life years gained were modelled for each of the three targets making the assumptions that the target would be achieved by concentrating on the oldest group, over 45, the older half of the population, age 35-64, and the youngest group, under 44. It was very clear from this work that, for men, the greatest gain could be achieved by concentrating on the oldest

men. There was less gain achievable in women, and there appeared to be less difference between the effects of targeting different age groups.

The full results of this initial modelling work are detailed in *Moving on - International perspectives on promoting physical activity* (Health Education Authority 1994) in Appendix C.

7.11 Discussion of Initial Results

These initial results are far from perfect predictions, given the number of assumptions, discussed above, that have had to be made when developing the model. Maybe the most important limitation of the data as they stand is the omission of the effects on the population aged over 65 year, where the majority of the CHD deaths can be expected to occur as the mortality rates at these ages are much higher than 65 years and below. This highlights a weakness in the setting of the targets that exclude the age groups where most deaths occur, and so underestimate their effect on a population. However, it appears from these data that the most effective strategy would involve concentrating on men in older age groups, and in particular those men who currently take no physical exercise.

The Task Force on Physical Activity were surprised at the lack of effect the interventions had in the younger age groups with respect to the reduction in CHD mortality, while the effect in the older age groups was larger. However, due to the number of targets and strategies modelled, I had not really explored the reason why this should be, and so with the second phase of modelling I hoped to investigate if some of my initial assumptions were responsible for this difference.

The Task Force's targets were never implemented, as the Government of the time decided to have less emphasis on targets since some of its Health of the Nation targets were not being met (Prentice 1995 and Troop 1997). Consequently, in 1996 a more general strategy statement, rather than specific targets, on physical activity (DoH 1996) was presented, with the following objectives:

- to promote the value of moderate activity on a regular basis for sedentary people;
- to inform people of the value of maintaining 30 minutes of moderate activity on at least 5 days a week for those who already take some moderate activity;
- to advocate, for those already taking some vigorous activity, the maintenance of a total of three periods of vigorous activity of 20 minutes a week.

These objectives made no mention of the proportion of the population to change their behaviour, the age groups being addressed, or the time in which the change should occur, and were designed to avoid criteria that can be evaluated in terms the achievement of policy goals.

7.12 Final Exercise Interventions

After this initial physical activity modelling it was decided to refine the strategies to be simulated, just concentrating on the one criterion for frequency of three periods of physical activity of 20 minutes duration a week, rather than the previous two criteria. This would allow for clearer comparisons between interventions. In the previous modelling I was not comparing like with like, and this made interpretation of the most effective strategy difficult. In addition, by limiting the number of strategies to be modelled it meant that I was able to expand the scope of modelling by investigating the effects of targeting by current level of physical activity, by more consistent age groupings than before, as well as allowing for some sensitivity analysis. In particular I wanted to explore some of the possible explanations for the difference in the effect of achieving the physical activity targets amongst the younger and older age groups.

7.12.1 Revised Strategies

To evaluate the potential effect of different strategies for physical activity promotion I explored two options representing interventions targeted at sedentary, lightly active and

moderately active people. These strategies were:

Strategy 1 - To encourage those who are either sedentary or lightly active to undertake moderate activity, thus increasing by 25% the proportion of the population aged between 15 and 64 which is moderately active.

Strategy 2 - To encourage those who are either sedentary, lightly active or moderately active to undertake vigorous activity, thus increasing by 25% the proportion of the population aged between 15 and 64 which is vigorously active.

The effect of these strategies in men and in women, and in different age groups were investigated separately.

Two scenarios were used to model each strategy to provide lower and upper limits of estimated outcomes. For Strategy 1, which aimed to increase the percentage of the population with a moderate level of physical activity, I simulated two scenarios that targeted either the sedentary group, or those already undertaking light activity. Strategy 2, which aimed to increase the number of people undertaking vigorous activity, was simulated using two scenarios which assumed that sedentary people would increase their activity to this level, or that those already taking moderate exercise would increase their level.

7.13 Final Intervention Outputs

I produced the outputs from the simulated interventions in terms of:

- Percentage reduction in coronary heart disease mortality rate, compared to 1994;
- Actual years of life gained.

These output were adapted from the outputs of the initial modelling on feedback from the Task Force when the initial results were presented. It was felt that the percentage reduction

in CHD mortality rate could be more readily interpreted than CHD mortality rate. Also since physical activity only had an effect on CHD mortality within the model; it was felt it was not necessary to produce results in terms of total mortality.

7.14 Final Results

There would be a very small reduction in the death rate from coronary heart disease associated with achievement of each of the two strategies in men and women under 95 years of age, see Table 7.7. This represents a fall of between 0.03% and 0.15% in men, and between 0.01% and 0.06% in women, across all age groups combined.

	Year	Strategy 1		Strategy 2	
		Lower	Upper	Lower	Upper
Males	1994	1382.5	1382.5	1382.5	1382.5
	2019	1381.3	1380.5	1382.1	1381.6
Females	1994	915.0	915.0	915.0	915.0
	2019	914.7	915.4	914.9	914.8

Table 7.7 – CHD mortality per 100,000 for males and females aged under 95 years achieving each strategy.

While the proportional reduction in the death rate appears disappointing, the actual years of life gained by the year 2019 was not insubstantial due to the size of the population (Figure 7.1). There was a roughly linear increase in actual years of life gained over time from 1994, illustrating that the interventions would be delaying deaths, although not enough to affect the mortality rate greatly. There were similar trends for both men and women, although the number of deaths postponed for men was about four times greater than for women. For both the upper and lower estimates Strategy 1 was the most effective in achieving life years gained. See Appendix D for the tables of the figures.

To examine the differing effect of targeting exercise interventions at various age groups, I modelled the life years gained for each of the two strategies making the assumptions that the strategy would concentrate on the older age groups, 45 to 64 years of age, or on the younger age groups, 15 to 44 years of age. Figure 7.2 shows this comparison in men and women in terms of actual years of life gained, using the mean of the two scenarios simulated. For both men and women, the greatest gain can be achieved by concentrating

on the older group. Again Strategy 1 was the most effective and, as before, there is less gain achievable in women than in men.

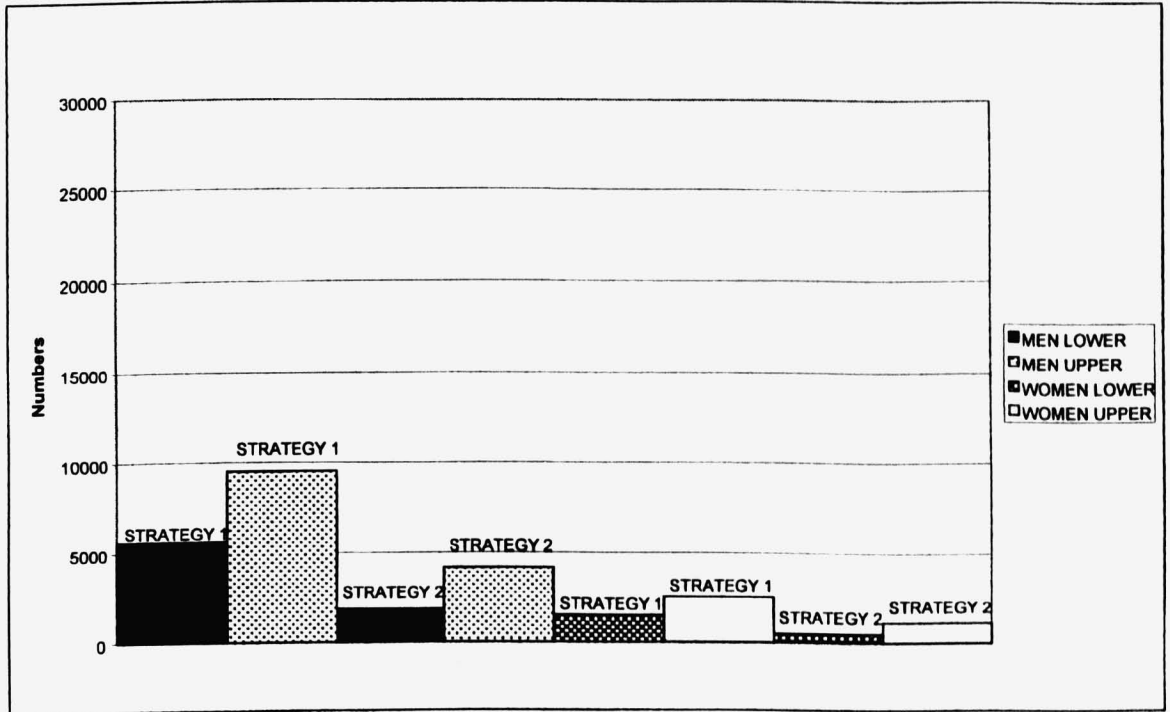

Figure 7.1 – Actual years of life gained for men and for women aged under 95 achieving each strategy by 2019.

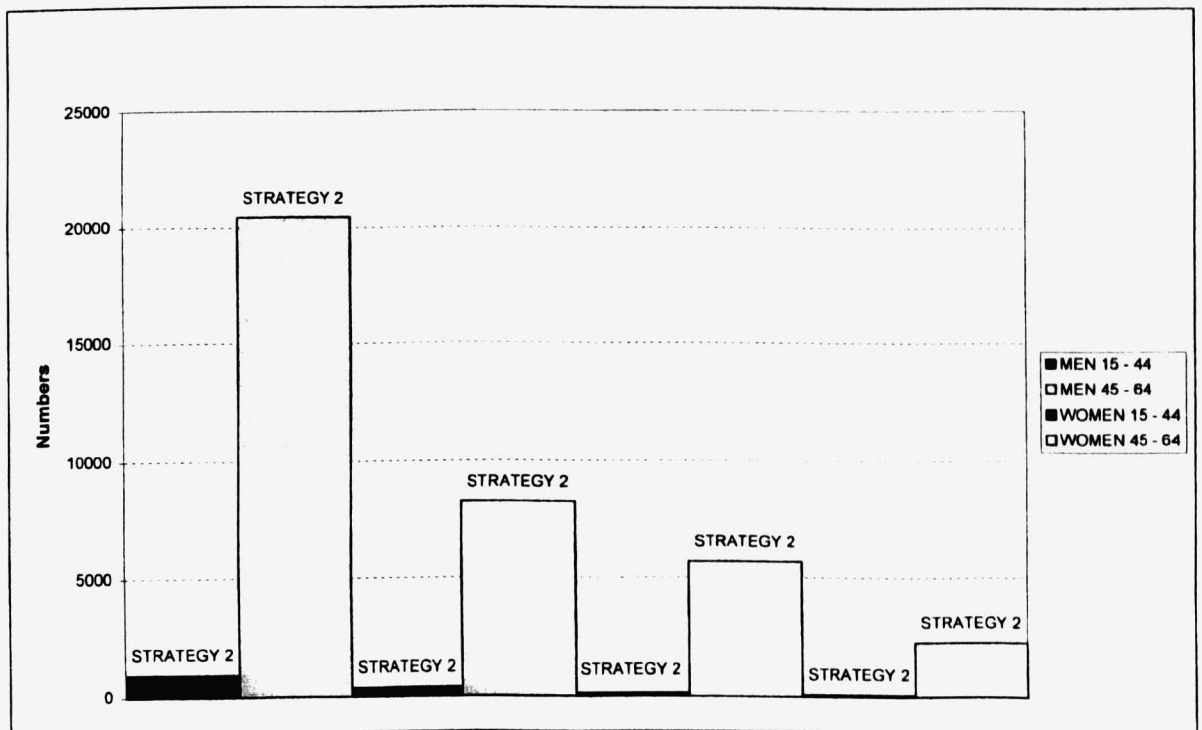

Figure 7.2 – Actual years of life gained for men and for women aged under 95 achieving each strategy by 2019, targeting by age group.

7.14.1 Sensitivity Analysis

It is possible that the increased relative risk associated with inactivity is attenuated in older people, since this was what Professor Gunning-Schepers found for the other risk factors within Prevent (Gunning-Schepers 1989). If this is true then the model will overestimate the effect of interventions in the elderly. I therefore carried out some sensitivity analysis for the simulations targeting those people 45 to 64 years of age, in which they were given lower relative risks for each level of physical activity. The relative risks are shown by age group in Table 7.8, they were estimated in consultation with Professor Gunning-Schepers by decreasing the relative risk by the same magnitude that she had for the other risk factors. This change made only a small difference to the number of deaths postponed, and targeting the older age groups still produced the greatest benefit (Figures 7.3 and 7.4). Modifying the remnant relative risks did not affect the results for those aged 15 to 44 years old.

Exercise Level	Age Groups			
	15-44	45-54	55-64	65+
Vigorous	1.0	1.0	1.0	1.0
Moderate	1.4	1.3	1.3	1.3
Light	1.7	1.6	1.5	1.4
Sedentary	1.9	1.8	1.7	1.6

Table 7.8 – Modified relative risks of CHD mortality in relation to physical activity level and age group.

The interventions were also simulated using the cohort option, as well as the modified relative risks, to check if this improved the results for those aged 15 to 44 years old. Under this option the intervention would be responsible for changing people's behaviour for the entire simulation period, in that those people that take up a new physical activity level will continue with this level of activity for 25 years, and not acquire the level of physical activity of each age group that the cohorts pass through as they age. Figures 7.3 and 7.4 shows that this increased the actual years of life gained when targeting the younger age group, but concentrating on people 45 to 64 years old still achieved the most health gain.

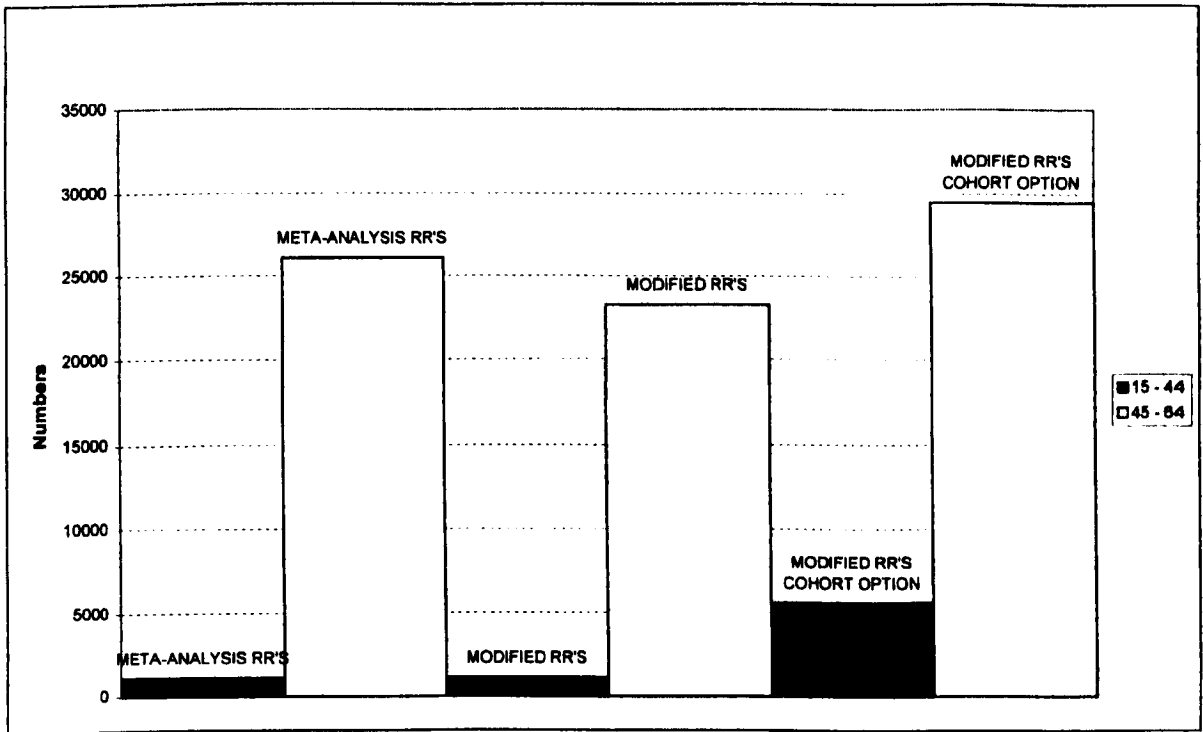

Figure 7.3 – Actual years of life gained for men and for women aged under 95 achieving Strategy 1 by 2019, targeting by age group, using modified relative risk and using the cohort option.

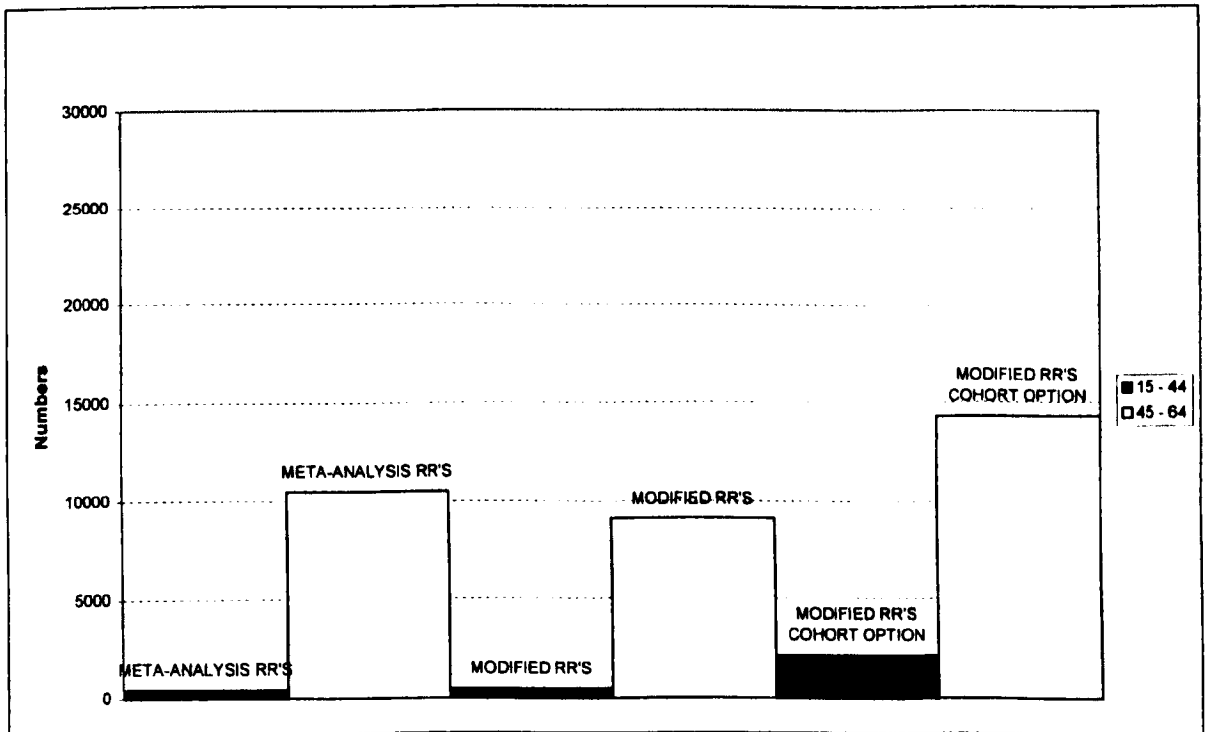

Figure 7.4 – Actual years of life gained for men and for women aged under 95 achieving Strategy 2 by 2019, targeting by age group, using modified relative risk and using the cohort option.

7.15 Discussion

There are a number of problems with using Prevent, most of which have been discussed when describing the assumptions I have had to make in order to fit physical activity data into the model. Prevent was initially designed for shifting exposure groups to non-exposure groups, rather than shifting exposure distribution. In addition, there were constraints on the stratification of the population, such as having to use multiples of five for the age group divisions, and risk factor exposure. One of the major drawbacks has been the lack of any estimate of changes in morbidity, especially if physical activity has much bigger effects on the prevalence of non-fatal disease. Work is currently underway to develop a new model (Barendregt 1994 and 1997, and Bonneux 1999) which takes into account morbidity, and this will greatly increase the applicability of the model.

The Prevent model may have underestimated the gain in mortality reduction from increasing physical activity since it is difficult to quantify the extent to which the relative risk of physical activity already accounts for the changes in the other established CHD risk factors such as hypertension, hyperlipidaemia, and obesity, as well as quantifying how the levels of these risk factors will change due to increased physical activity. I have assumed that physical activity will not affect the prevalence of these risk factors. I have also assumed that increased physical activity will not affect mortality from any other cause of death included in the Prevent model. However, of the causes of death modelled in Prevent, the only other cause that is likely to be affected is death from accidental falls (US Department of Health And Human Services 1996). This would nevertheless result in some underestimation of the effect of physical activity on mortality.

Prevent has been used to explore the effect of different strategies which might be undertaken to increase physical activity in the population. None of the strategies modelled appeared to have much effect on reducing predicted CHD mortality, although the most effective strategy appeared to be to encourage sedentary people to undertake moderate activity. If the proportion of the population undertaking moderate activity was increased by 25% as a result of this strategy, then approximately 12,100 years of life would be gained over 25 years. This is very similar to the health gain that could be achieved by a reduction

of 2% in the proportion of smokers in the population. The latter might, arguably, be easier to achieve (Silagy 1994).

The reason for the interventions having little effect on the CHD mortality rate for the population up to the age of 95 is that the majority of deaths from CHD in the population occur in those over the age of 65, while these interventions concentrate on those under 65. The most effective strategy would achieve a 2.6% reduction for men and a 2% reduction for women in the CHD mortality rate up to age 65 years.

The greater effect of Strategy 1 as compared with Strategy 2 could be because more people receive the intervention, 39.3% of the population aged between 15 and 64 are moderately active, while only 10.7% are vigorously active. Increasing each category by 25% results in 49.1% of the population in this age group undertaking moderate activity and 13.4% undertaking vigorous activity.

The proportion of the population at risk of CHD in the older age group has a significant impact on the relative effectiveness of the interventions by age group. This is emphasised when using attenuated relative risks for the older age group in the simulation, since the actual years of life gained for this age group still outweighs that for the younger age group, even though sedentary people in the younger age group have higher relative risks.

The use of the cohort option in the simulation showed that the targeting of older age groups was still more effective, in terms of the actual years of life gained over 25 years, than targeting younger cohorts who would retain their new physical activity levels over time. Again, this is probably because of the higher CHD mortality rates amongst the older age groups in the England & Wales population. A proportionally smaller reduction in a large risk may be more beneficial at a population level than a large reduction in a small risk.

The marked difference between the results for men and women reflects the fact that women have a much lower mortality rate for CHD than men, particularly between the ages of 25 and 64 where the difference in the CHD mortality rate ranges from three to six and a half times lower for women.

The published account of this modelling work is detailed in *Modelling the effects of increased physical activity on coronary heart disease in England and Wales* (Naidoo 1997) in Appendix E.

7.16 Reflections

This work was invaluable in terms of my realising the complexity and difficulties, that are not apparent in the model's user manual, involved in adding a new risk factor to the Prevent. The manual outlines the process as being quite simple. It is not just a matter of adding the appropriate prevalences of the new risk factor to the model, and then applying the disease specific relative risks to each risk factor exposure category. When adding a risk factor questions concerning the accuracy and appropriateness of the risk factor prevalences are raised. There is also the problem of finding suitable relative risks which match the risk factor exposure categories. The user must consider whether the risk factor is cohort or age group specific, what movement between risk factor exposure categories are likely to occur, and what is the time period over which an individual's risk will change after moving to a new risk factor exposure category.

The most surprising aspect of the work was my realisation that Prevent could only be used for modelling the movement of individuals from risk factor exposure categories to a non-exposure category, since this point is never explicitly made in the literature. Fortunately I was able to adapt the model in order to simulate the proposed targets, but I would not have been able to model any interventions that shifted a population's risk factor distribution, as opposed to moving individuals to just one lower risk factor exposure category.

I found it interesting how the modelling could raise questions concerning the relationship between the risk factor and the linked disease which could then be explored more fully by adapting the model. For example, investigating reasons why the interventions were more effective in the older age groups, allowed me to test a number of alternative hypotheses, but also made me think more about feasible explanations for the results.

It was disappointing that, although the work was intended to inform the debate on the setting of physical activity targets, the fact that health targets became a political hot potato had more effect on the targets not being adopted than did the weight of research. This shows how difficult it can be for research to keep up with the policy agenda. This can be problematic for modelling, since the policy agenda could change markedly in the time it takes to develop a model that will address the original agenda.

The weakest aspect of this modelling exercise in my opinion is the use of the meta-analysis by Berlin and Colditz, which was not ideal in terms of its definitions of physical activity levels. In addition, the meta-analysis was published 9 years ago, and since then the results of several large physical activity trials have been published (Morris 1990, Shaper 1991, and Manson 1999) which should be included in an updated meta-analysis. However, it may still be difficult to find appropriate relative risks by age and sex; since it is difficult to find trials that are applicable to a whole population. This highlights that, sometimes, the best obtainable data for modelling must be used to address policy questions when the ideal data do not exist. The modellers, and those who are using the results of the model, should always be aware of the weaknesses of the data on which the model is based.

7.17 Conclusions

Even if Prevent has underestimated the total gain possible from increasing physical activity, the relative gain of different strategies carries an important message. My work with Prevent indicates that the greatest health gain can be achieved by concentrating on sedentary people, on older people and on men. This may seem a contradiction of Rose's argument that preventive strategies which concentrate on a minority at high risk produce less health gain than strategies which intervene across the whole population, since the minority at high risk contribute a small proportion of adverse events (Rose 1992). However, the majority of older men, 45 plus, do not undertake even moderate exercise, and older men account for about 67% of coronary death under the age of 75. In this case, then, the most effective strategy is the one which concentrates on that section of the population which is contributing the majority of the deaths.

The modelling process was very instructive in terms of gaining a better understanding of the works of the model, as well as the difficulties and complexities of updating a model. It showed how although Prevent could be used to model these targets; it could not model interventions which would shift the risk factor distribution of a population, such as would possibly be the effect of a national campaign to increase physical activity overall. Before modelling any interventions it is important to decide what is the appropriate model to simulate such an intervention.

7.18 Summary

This chapter details my work for the Health Education Authority in adapting the Prevent model to include lack of physical activity as a risk factor for CHD in the England & Wales population. It details how the model has been used to simulate various strategies to achieve physical activity targets being considered by the Task Force on Physical Activity, targeting by age, sex and current level of physical activity in order to contribute to the policy debate in setting such target.

Prevent was a useful tool in comparing the effect of different strategies to achieving physical activity targets in the populations. It demonstrated its ability to make these comparisons using various targeting strategies, as well as various hypothesis concerning how physical activity affects CHD mortality when current knowledge is open to debate. This exercise also highlighted the lack of data for inputting to the model. Modellers sometimes have to use the best available data to answer policy questions, while being aware of their limitations.

The chapter illustrates how Prevent could be used to simulate proposed targets or strategies in order to inform debate on policy. The chapter also highlights how the politics behind the policy of target setting can be a more powerful force than the research results in setting the policy agenda, with the proposed targets being turned into a more general strategy statement at a time when attention was being drawn to other unmet health targets.

Chapter 8 - Birmingham Interventions Modelled With PREVENT

8.1 Introduction

As a result of my earlier work with Prevent in modelling physical activity targets for the Health Education Authority I was approached by Dr Jackie Chambers, Director of Public Health, and her colleagues at Birmingham Regional Health Authority who wanted the Prevent model adapted to the Birmingham population. They were interested in making comparisons between risk factor intervention strategies targeting by age, sex and risk factor as a possible aid to policy decision making. In particular they were interested in simulating short term risk factor interventions in the Birmingham, Small Heath and Sutton Coldfield populations, and assessing their effectiveness in terms of actual years of life gained over time (25 years). We decided that this would be best achieved as a two stage process, with an initial set of interventions simulated, which would give the policymakers at Birmingham Regional Health Authority a better understanding of the workings and capabilities the Prevent model, and then to refine the set of health interventions modelled to be more specific to the public health issues that they wanted to address.

8.2 Choosing a Version of PREVENT to Adapt

Having adapted the Prevent model to the 1991 England & Wales population for my work on physical activity; I chose to use this model, using the same set of risk factors, risk factor exposure categories and diseases, as the basis for the Birmingham models. The version of Prevent included the following risk factors:

- cigarette smoking,
- hypertension,
- cholesterol,
- alcohol,
- lack of physical activity,

and the following diseases:

- coronary heart disease,
- cerebrovascular accident,
- chronic obstructive lung disease,
- lung cancer,
- cirrhosis of the liver,
- breast cancer,
- traffic accidents,
- accidental falls.

8.3 Adaptation of PREVENT

I adapted my existing 1991 England and Wales model to create three separate models for the Birmingham, Small Heath and Sutton Coldfield populations. This entailed the input of data for each population on:

- population structure,
- total mortality probability,
- birth projections,
- disease specific mortality probabilities,
- risk factor exposure prevalences.

There was no problem with the availability of Birmingham population, birth projection and mortality data down to a constituency level, which was supplied to me by Birmingham Health Authority. The Authority also supplied risk factor prevalence data, from the Pulse Survey, a health survey of the Birmingham region. Most of the risk factors related closely to the existing Prevent exposure levels, except for blood pressure and cholesterol which were recorded in terms of a yes/no treatment response.

Unfortunately these data were problematic at the regional level, particularly in terms of smoking data, since the Pulse Survey only had a 35% response rate at region level.

As a consequence of the lack of blood pressure and cholesterol information by exposure level; other data sources needed to be identified to provide this information, otherwise national or regional prevalence levels would have had to be used, which may not have been appropriate for the Birmingham population. I considered the possibility of using different data sources including the data archive for the Health Survey, VAMP data and the GP morbidity data, as well as possibly using data on Wolverhampton, which had had its own health survey and which was thought to have a similar population to Birmingham by those at Birmingham Health Authority.

In the end I chose to extract data on risk factor prevalences for the risk factors that were unavailable, or that were thought to be unreliable, from the 1993 Health Survey for England, supplied by the ESRC Data Archive, for the West Midlands and Trent regions, and used them as the best approximation available. Data on prevalences were extracted for the following risk factors from the 1993 Health Survey:

- smoking (for Birmingham only, with the constituency data taken from the Pulse Survey),
- hypertension,
- cholesterol,
- untreated hypertensives.

Those at Birmingham Health Authority thought that the smoking data from the Pulse Survey was more representative for the constituencies, since there was a better response rate at that level, than at the regional level. While for hypertension and cholesterol there was a similar poor response rate at both constituency and regional level, possible due to these risk factors requiring a medical examination which individuals would be more likely to refuse than the questionnaire response required for the measurement of smoking, as was witnessed with the Health Survey for England (Bennett 1995).

Untreated hypertensives were classed as those individuals with a diastolic blood pressure above 95 mmHg who also answered no to the question “*Are you currently taking any medicines, tablets or pills for high blood pressure?*” in the Health Survey For England 1993.

Prevalence data on physical activity levels for Birmingham and the two constituencies were taken from the Pulse Survey. Physical activity levels were classified as none, light, moderate and vigorous, and these were assumed to match the levels for the relative risks used in my previous work on physical activity, which were taken from the meta-analysis by Berlin and Colditz (Berlin 1990), see Chapter 7.

The tables in Appendix F shows this background population data for each of the three populations by sex and age groups.

8.3.1 Importance of Ethnic Mix

Ideally the ethnic mix of Birmingham should have been taken into consideration, since 1 in 4 members of the population come from an ethnic minority. This is important in terms of the prevalence of diabetes amongst the Asian communities and hypertension in the Afro-Caribbean community. In theory ethnicity could have been modelled within Prevent in two ways:

1. by stratifying the risk factor prevalences by ethnic group as well as age, sex and exposure category, with different relative risks of disease mortality for each cell of stratification;
2. by stratifying the population by ethnic group as well as sex and age, which would have involved the input of population data (all cause and disease specific mortality probabilities, population structure, birth projections and risk factor prevalences) for each ethnic group to be included in the model.

I investigated the possibility of implementing these two methods, but due to the methodology of Prevent only allowing a limited number of risk factor exposure categories, as outlined in Chapter 3, and due to there being no regional risk factor prevalence or mortality data by ethnic group, it was not possible to include ethnicity as part of the model.

STAGE ONE

8.4 Initial Meeting

The first step was to have an initial meeting at Birmingham Regional Health Authority with Dr Jackie Chambers and her colleague Mr Stuart Harris to discuss what they wanted modelled. Dr Chambers was already familiar with my work with Prevent for the HEA on physical activity, but in order to give a broader view of the capabilities of Prevent I gave a presentation on the data requirements of the Prevent model, and on the type of simulations that could be run, the range of risk factors that could be intervened on, and the targeting within populations that could be employed.

They identified three areas that they were interested in:

- Reducing smoking, which they were currently spend £0.3 million per year on, and so were interested in estimating the increased health gain due to reducing the prevalence of smoking;
- Increasing physical activity, since they were interested in extrapolating the work I had done on the England & Wales population to the Birmingham population;
- Screening and treating hypertension, since it was an area originally highlighted by the Health Survey for England 1991 for fuller coverage, with 13% of men and 11% of women being hypertensive and not currently taking any drugs that could affect blood pressure.

In addition, Dr Chambers was interested in modelling the effects of the same interventions at constituency level, and in particular comparing the effects of these interventions in Sutton Coldfield, the most affluent constituency in Birmingham, with Small Heath, the most deprived constituency in Birmingham. Both constituencies have roughly the same size population (Small Heath has a population of 84727 people and Sutton Coldfield has a population of 92283 people), but have different age and sex structure, birth and death rates, and risk factor profiles, and so it would be of interest to investigate how these differences affected the outcome of exactly the same interventions in each population. Consequently it was decided to build separate models for the Sutton Coldfield and Small Heath populations, as well as a model for the whole of the Birmingham population.

8.5 Choosing the Interventions

The interventions chosen involved simulating the reduction in the prevalence of risk factors over time. However, the changes in prevalence of these first set of interventions were not chosen on the basis of any policy targets of the Birmingham Health Authority, or on what could realistically be achieved by a public health intervention, but what Dr Chambers and Mr Harris felt were reasonably achievable reductions in risk factor prevalence.

The first set of interventions decided upon were:

Smoking:

- 1.0% reduction in the overall prevalence of cigarette smoking,
- 2.0% reduction in the overall prevalence of cigarette smoking,
- 3.0% reduction in the overall prevalence of cigarette smoking.

Physical activity:

- 5.0% increase in the prevalence of moderate physical activity,
- 10.0% increase in the prevalence of moderate physical activity,
- 15.0% increase in the prevalence of moderate physical activity.

These interventions were simulated targeting those people who were sedentary, and those who were lightly active as a means of calculating the bounds for what could be achieved by such interventions. In a best case scenario all the people who became moderately active would have been sedentary before the intervention, and so increasing their physical activity level by two categories, which in terms of relative risk of CHD mortality translates to moving from a relative risk of 1.9 to a relative risk of 1.4 within the model. While in the worst case scenario all those who became moderately active would have been lightly active before the intervention, and so only increasing their physical activity level by one category, which in terms of relative risk of CHD mortality translates to moving from a relative risk of 1.7 to a relative risk of 1.4.

Hypertension:

- 20.0% screening and successfully treating of untreated hypertensives in the population,
- 30.0% screening and successfully treating of untreated hypertensives in the population,
- 40.0% screening and successfully treating of untreated hypertensives in the population.

These interventions were simulated by first assuming that untreated hypertensives who were screened and then successfully treated, so that they became normo-tensive, were all severe hypertensives (diastolic blood pressure above 95 mmHg), and then assuming

that all were mild hypertensives (diastolic blood pressure between 90 and 94 mmHg). Again this was done as a means of calculating the bounds for what could be achieved by such interventions, with the best case scenario being that all the people who became normo-tensive after screening and treatment would have been severely hypertensive before the intervention. In terms of relative risk of mortality within the model this translates, for example, to moving from a relative risk for CHD mortality of 2.3 to a relative risk of 1.6, and a relative risk for CVA mortality of 5.0 to a relative risk of 1.5 for men aged under 45 years. In the worst case scenario all those who became normo-tensive after screening and treatment would have been mildly hypertensive before the intervention. In terms of relative risk of mortality, again as an example for men aged under 45 years, this translates to moving from a relative risk for CHD mortality of 1.9 to a relative risk of 1.6, and a relative risk for CVA mortality of 3.5 to a relative risk of 1.5.

For the 40% screening and treating intervention both mild and severe hypertensives were screened and successfully treated since the percentage decreases in prevalence were larger than each hypertension category prevalence alone.

Within the model cigarette smoking is a risk factor for lung cancer, chronic obstructive lung disease, CHD and cerebrovascular accident (CVA), lack of physical activity is a risk factor for CHD, and hypertension is a risk factor for CHD and CVA.

The same interventions were simulated for the Small Heath and the Sutton Coldfield populations as for the Birmingham population.

8.6 Running the Model

The simulations were run for 34 years from 1991 (the base year), with the interventions beginning in 1996 and the target risk factor prevalences being achieved in 2005 (a target year for the Health of the Nation). The simulations then ran for a further 20 years, with risk factor prevalences at their new level, until 2025.

The effect of the interventions was measured in terms of actual years of life gained and disease specific mortality.

8.7 Results of the Modelling

8.7.1 Birmingham Simulations

Smoking interventions resulted in a greater number of actual years of life gained for males than for females, with the interventions having approximately twice the effect in males as in females (see Figures 8.1 and 8.2). For both males and females each increase in the percentage reduction in the prevalence of smoking led to a stepwise increase in the actual years of life gained.

Physical activity interventions resulted in a greater number of actual years of life gained for males than for females due to the higher CHD mortality rate in men at all ages, and targeting the sedentary rather than the lightly active resulted in a greater number of actual years of life gained (Figures 8.3, 8.4 and 8.5). The intervention on lightly active males was equivalent to the intervention on sedentary females. In addition, the actual years of life gained continued to increase for males, while for females they increase less markedly after 12 years, due to there being more females than males in the population only after 62 years of age, and these females still having a lower mortality rate than males of the same age. Again each increase in the percentage of those people undertaking moderate activity saw a stepwise increase in the number of actual years of life gained.

Hypertension screening interventions, targeting the severe hypertensives, resulted in a greater number of actual years of life gained for females, nearly twice that for males, while targeting the mild hypertensives had a negligible effect, particularly amongst females. Increasing the percentage of treated hypertensives resulted in a stepwise increase in the actual years of life gained (Figures 8.6, 8.7 and 8.8).

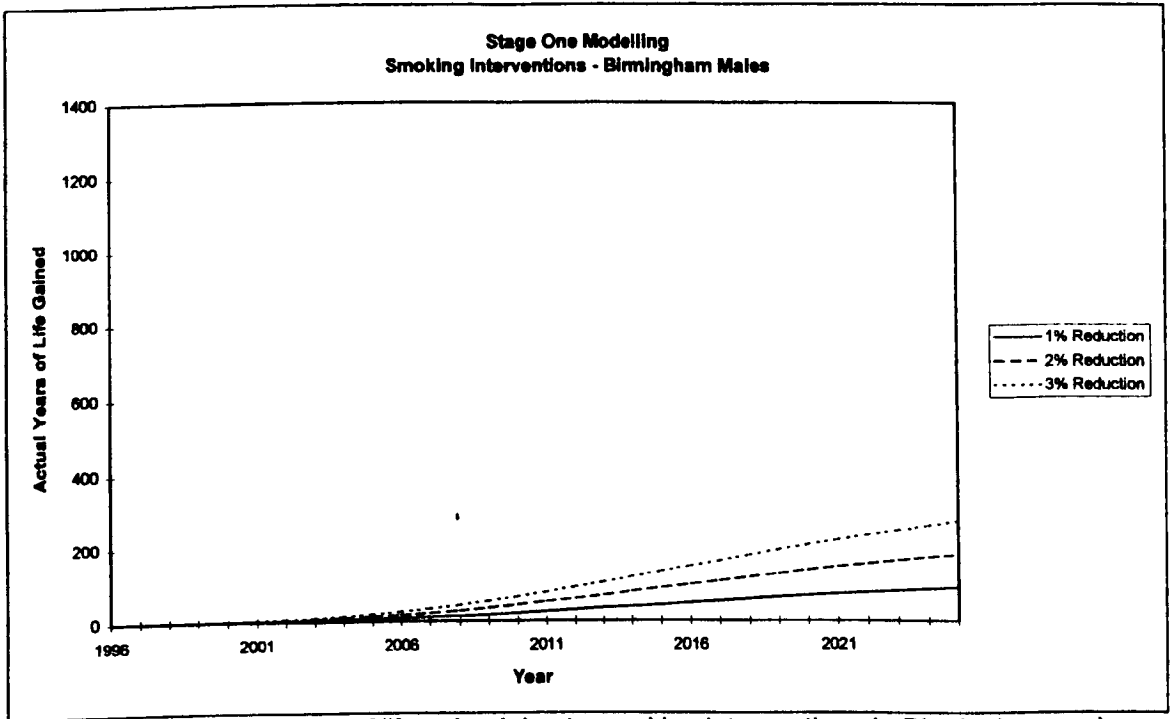

Figure 8.1 – Actual years of life gained due to smoking interventions in Birmingham males

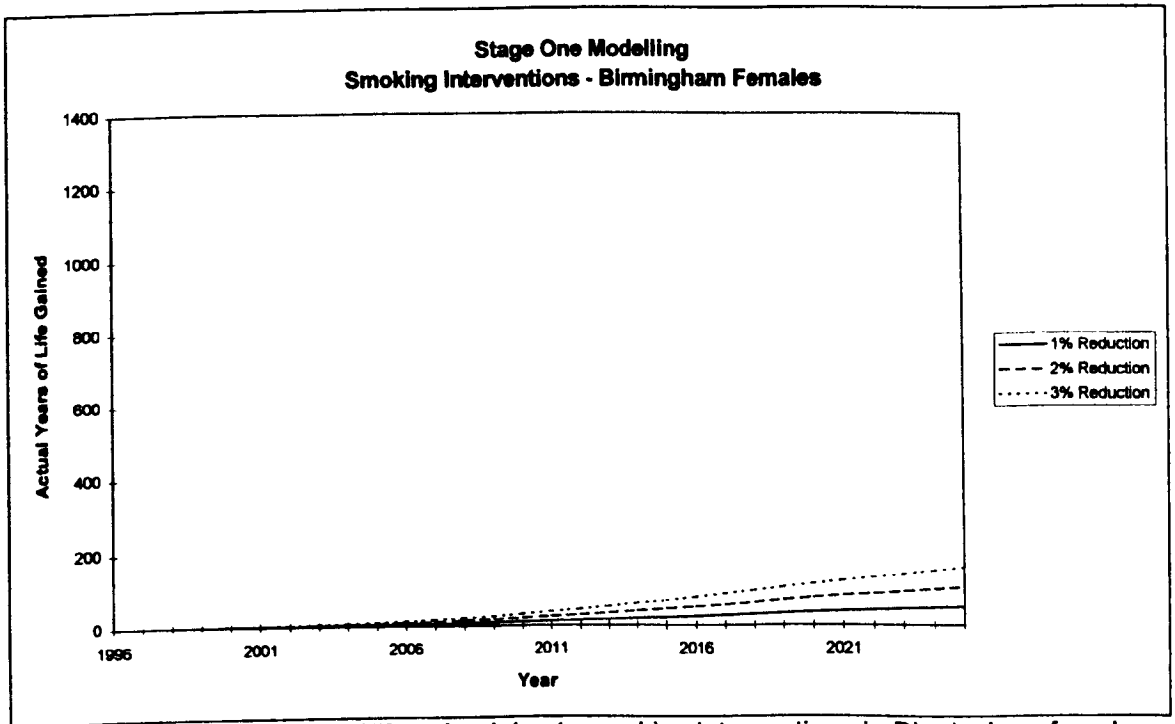

Figure 8.2 - Actual years of life gained due to smoking interventions in Birmingham females

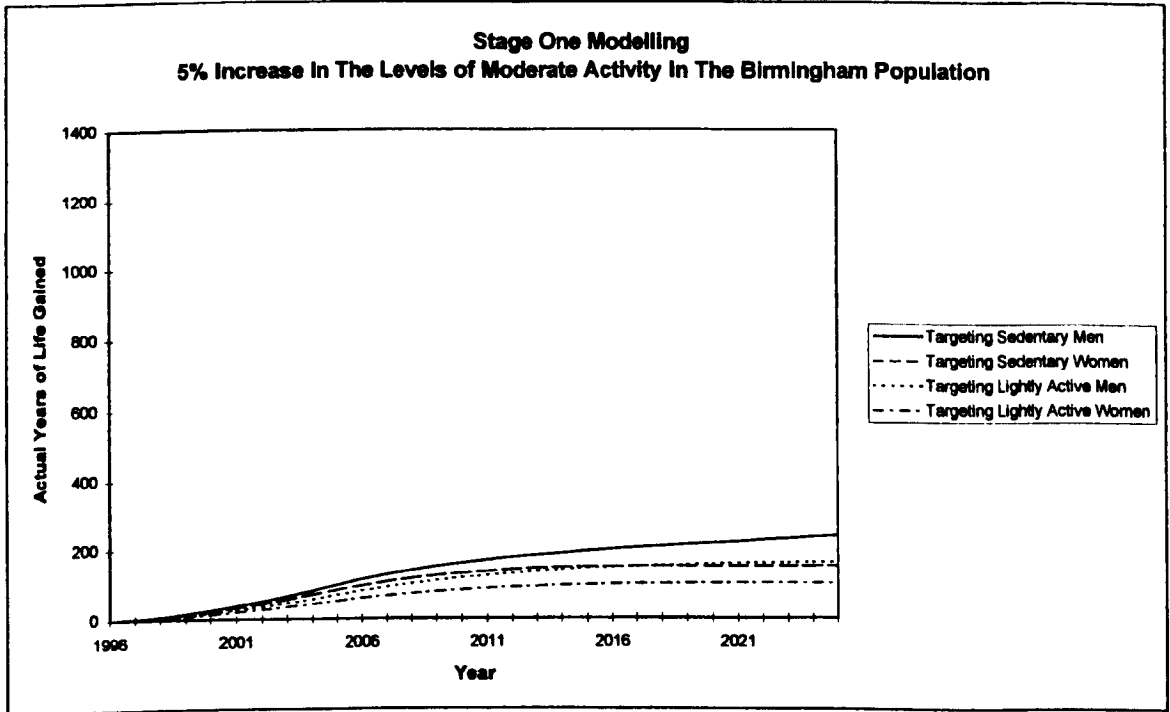

Figure 8.3 - Actual years of life gained due to a 5% increase in the levels of moderate activity in the Birmingham population

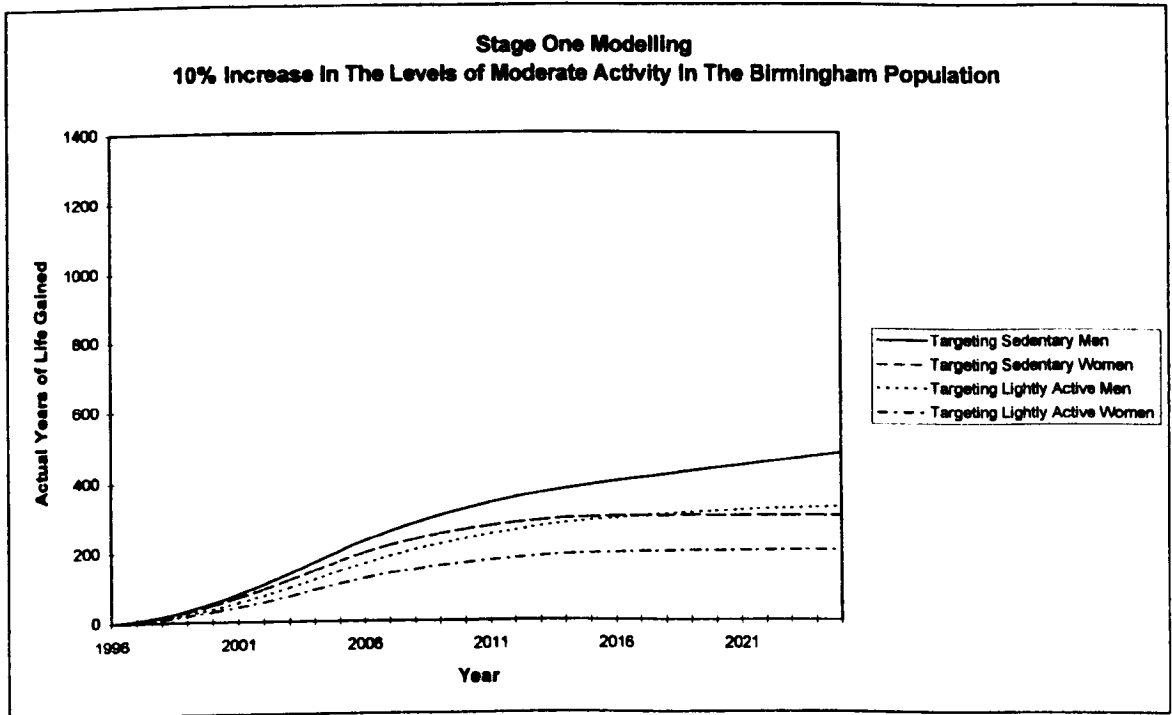

Figure 8.4 - Actual years of life gained due to a 10% increase in the levels of moderate activity in the Birmingham population

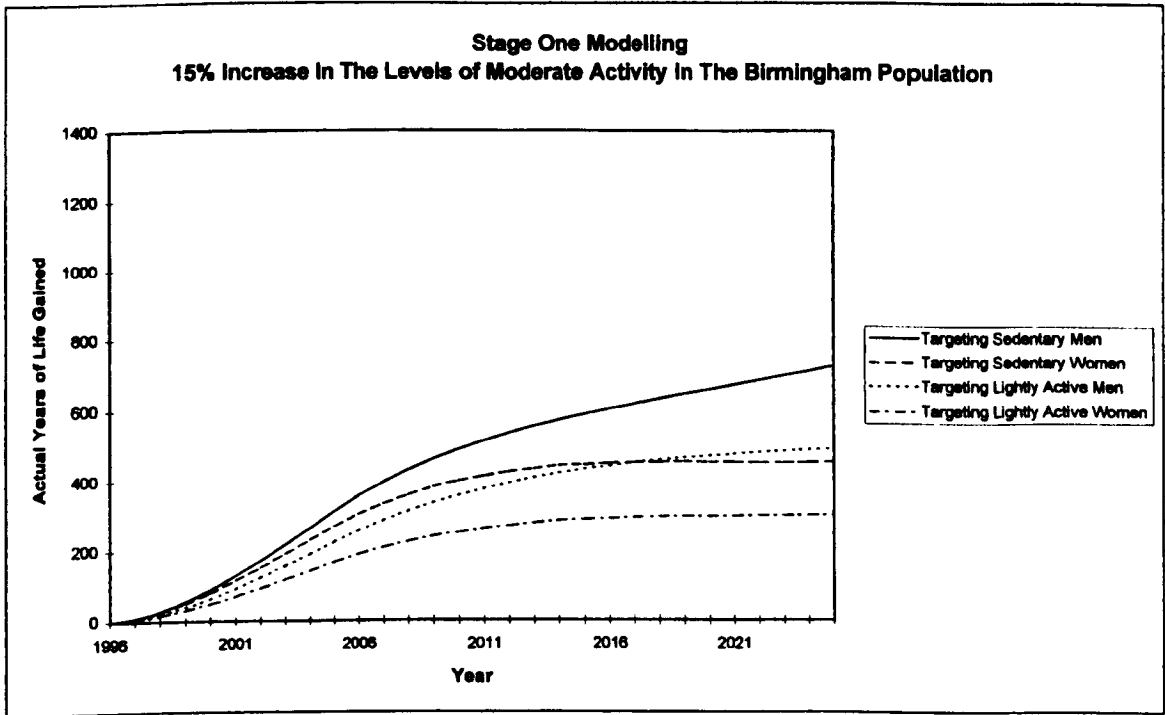

Figure 8.5 - Actual years of life gained due to a 15% increase in the levels of moderate activity in the Birmingham population

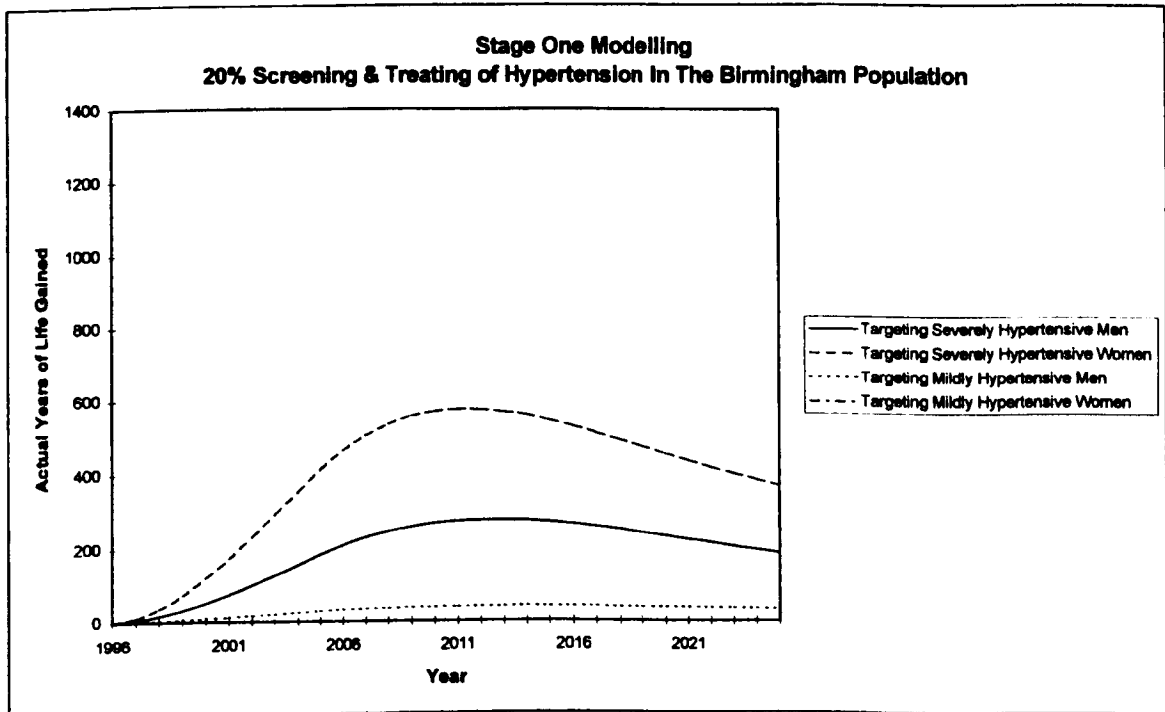

Figure 8.6 - Actual years of life gained due to a 20% screening and treating of hypertension in the Birmingham population

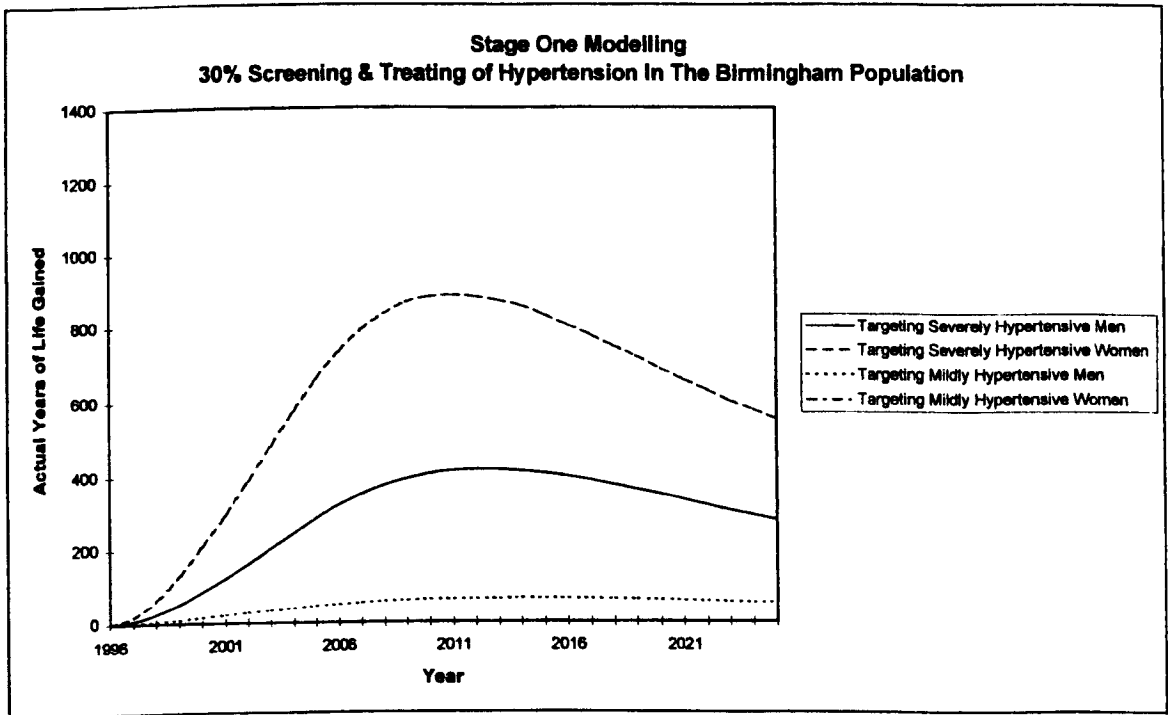

Figure 8.7 - Actual years of life gained due to a 30% screening and treating of hypertension in the Birmingham population

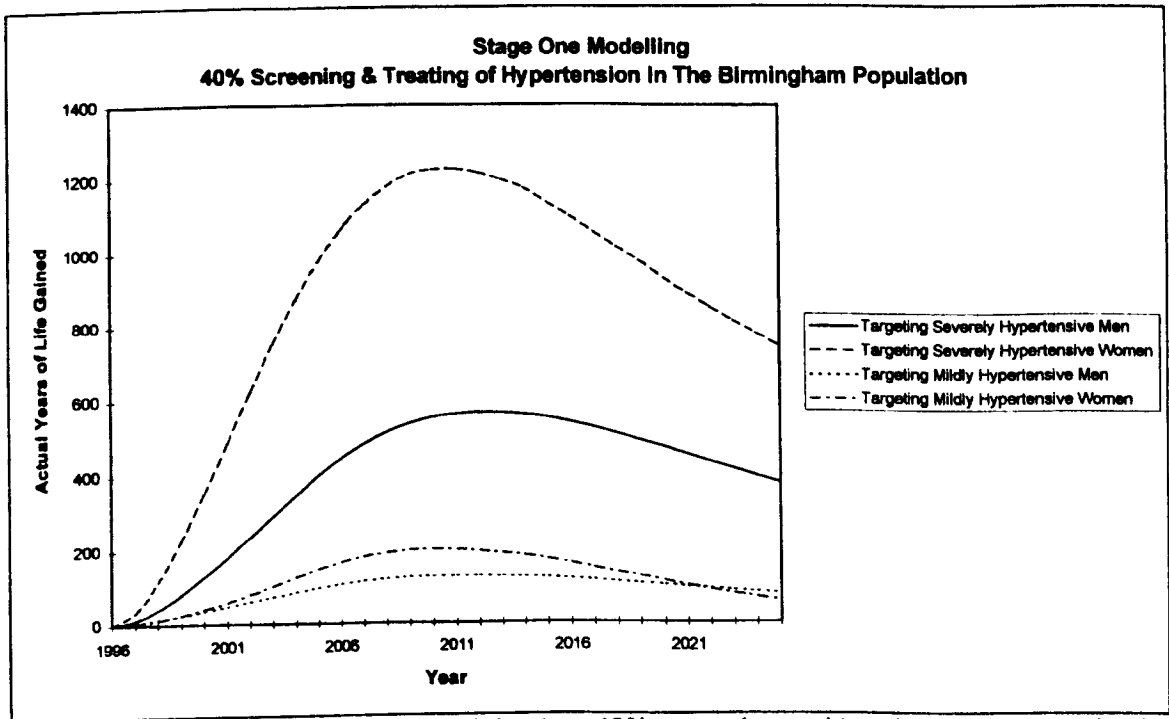

Figure 8.8 - Actual years of life gained due to a 40% screening and treating of hypertension in the Birmingham population

8.7.2 *Small Heath and Sutton Coldfield Simulations*

Smoking interventions resulted in a greater number of actual years of life gained for males than for females, and were responsible for more actual years of life gained in the Small Heath population compared to that of Sutton Coldfield (see Figures 8.9, 8.10 and 8.11). However, the number of actual years of life gained was very small for both populations, and for all the interventions due to the populations being small, although the number of actual years of life did increase with each increase in the percentage reduction.

Physical activity interventions resulted in a greater number of actual years of life gained for males than for females, and targeting the sedentary rather than the lightly active resulted in a greater number of actual years of life gained (Figures 8.12 to 8.17). When targeting the sedentary the interventions were responsible for more actual years of life gained in Sutton Coldfield males than compared to that of Small Heath, while for females there were a greater number of actual years of life gained amongst those in Small Heath compared to those in Sutton Coldfield, although before 2012 the females of Sutton Coldfield achieve more actual years of life gained. The interventions aimed at the lightly active produced similar results, except that the Small Heath females achieved more actual years of life gained for the whole of the simulation period, and in the 10% and 15% interventions for the males the actual years of life gained for Sutton Coldfield peaks in 2020 then begins to fall, while that for Small Heath continues to rise.

Hypertension screening interventions, targeting the severe hypertensives, resulted in a greater number of actual years of life gained for females than for males (Figures 8.18 to 8.23). While targeting the mild hypertensives had a very small effect, particularly amongst females. Again the interventions were responsible for more actual years of life gained in Sutton Coldfield males than compared to that of Small Heath, while for females there were a greater number of actual years of life gained amongst those in Small Heath, which began to level off in 2016, compared to those in Sutton Coldfield, which peaked in 2011 and then began to fall.

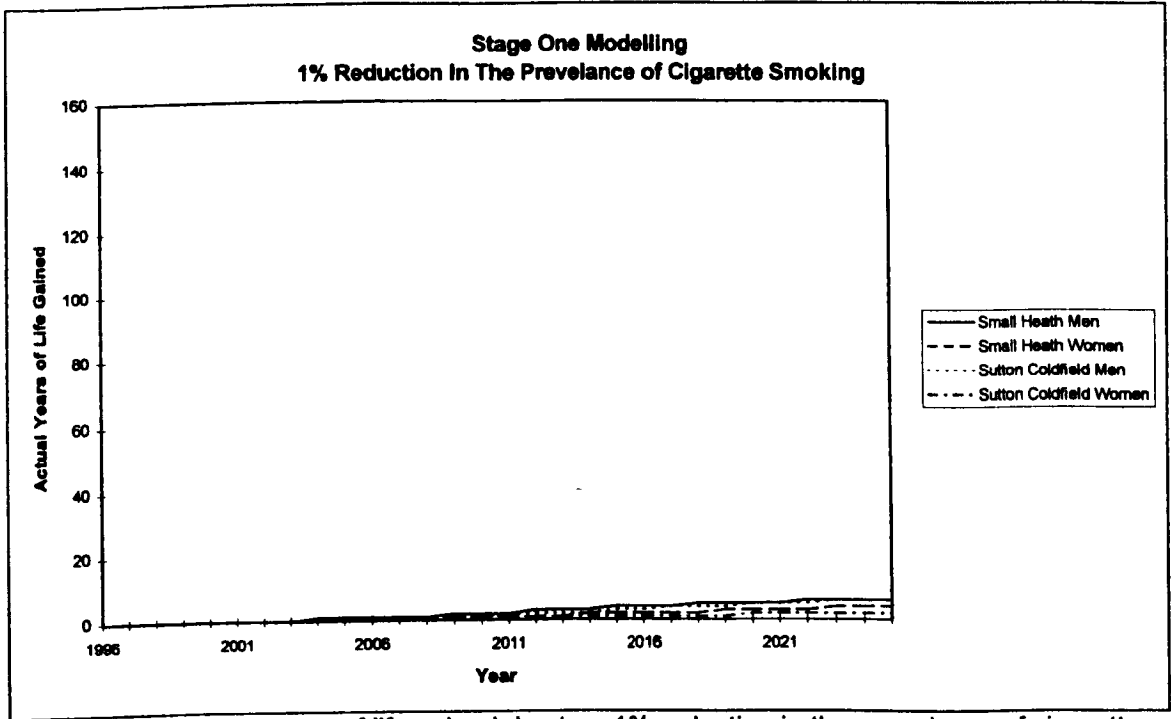

Figure 8.9 - Actual years of life gained due to a 1% reduction in the prevalence of cigarette smoking in the Small Heath and Sutton Coldfield populations

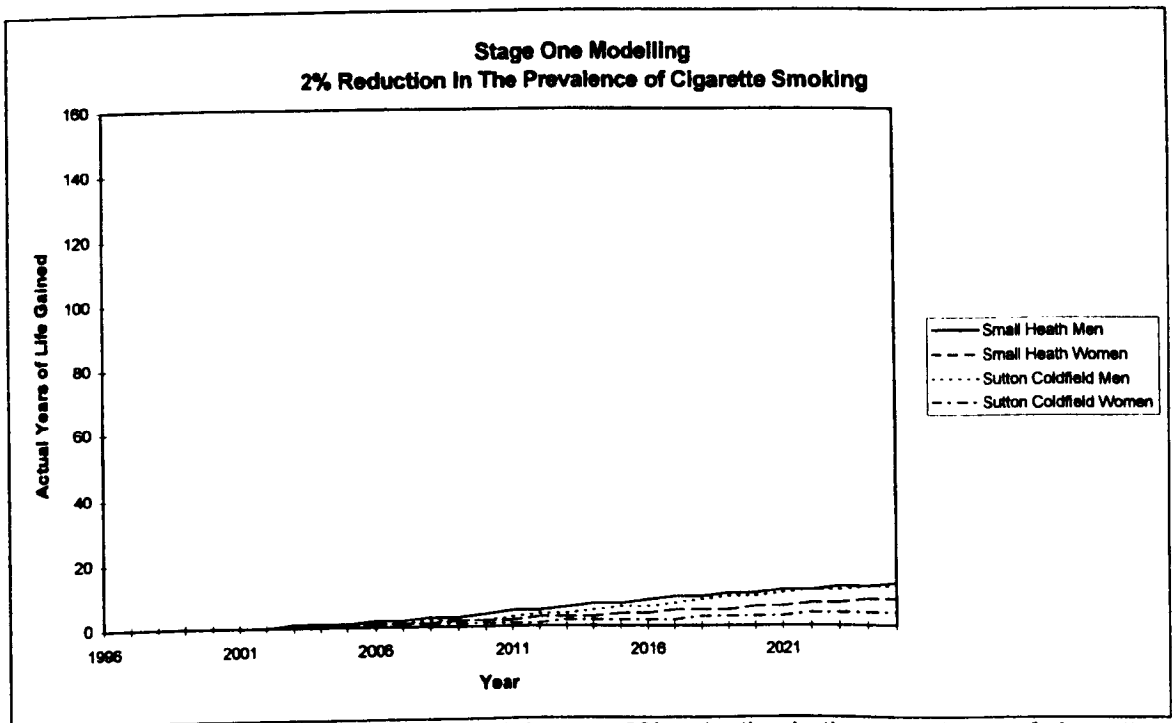

Figure 8.10 - Actual years of life gained due to a 2% reduction in the prevalence of cigarette smoking in the Small Heath and Sutton Coldfield populations

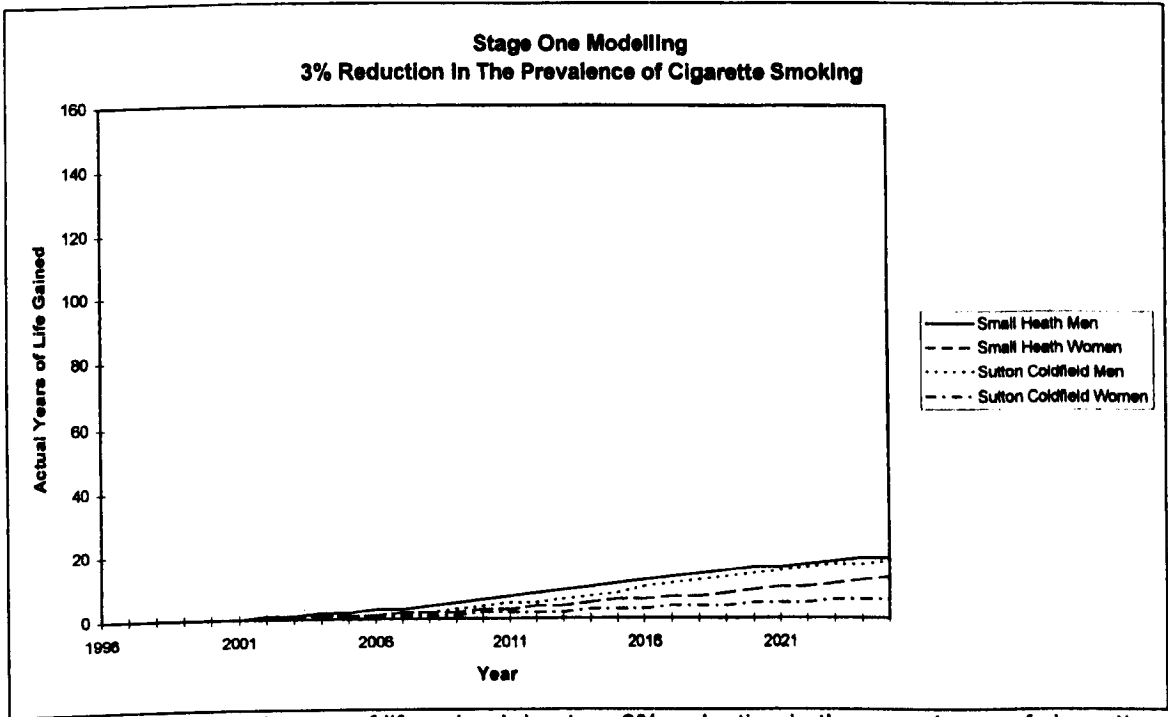

Figure 8.11 - Actual years of life gained due to a 3% reduction in the prevalence of cigarette smoking in the Small Heath and Sutton Coldfield populations

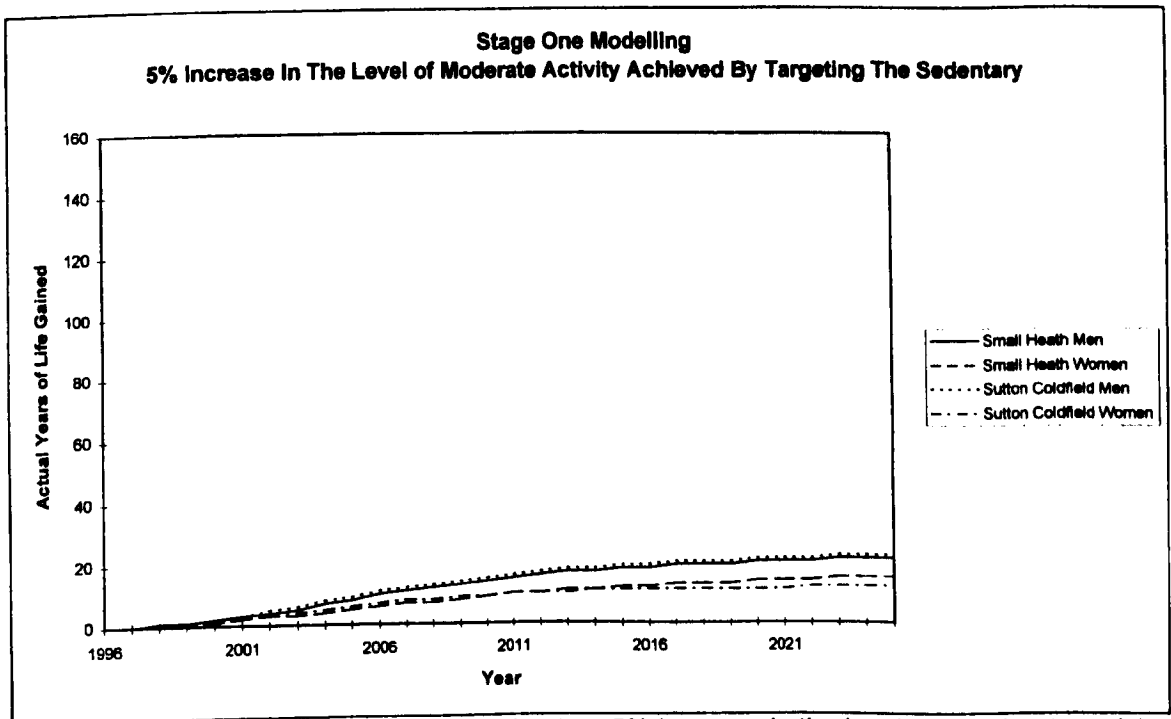

Figure 8.12 - Actual years of life gained due to a 5% increase in the levels of moderate activity achieved by targeting the sedentary in the Small Heath and Sutton Coldfield populations

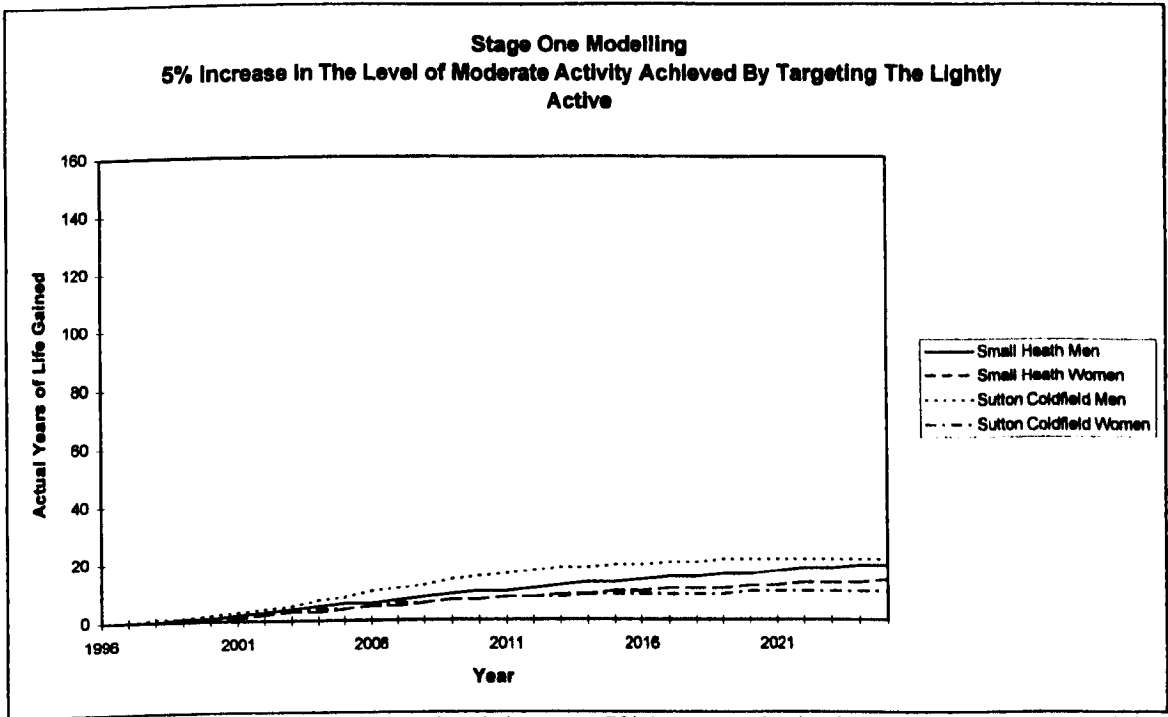

Figure 8.13 - Actual years of life gained due to a 5% increase in the levels of moderate activity achieved by targeting the lightly active in the Small Heath and Sutton Coldfield populations

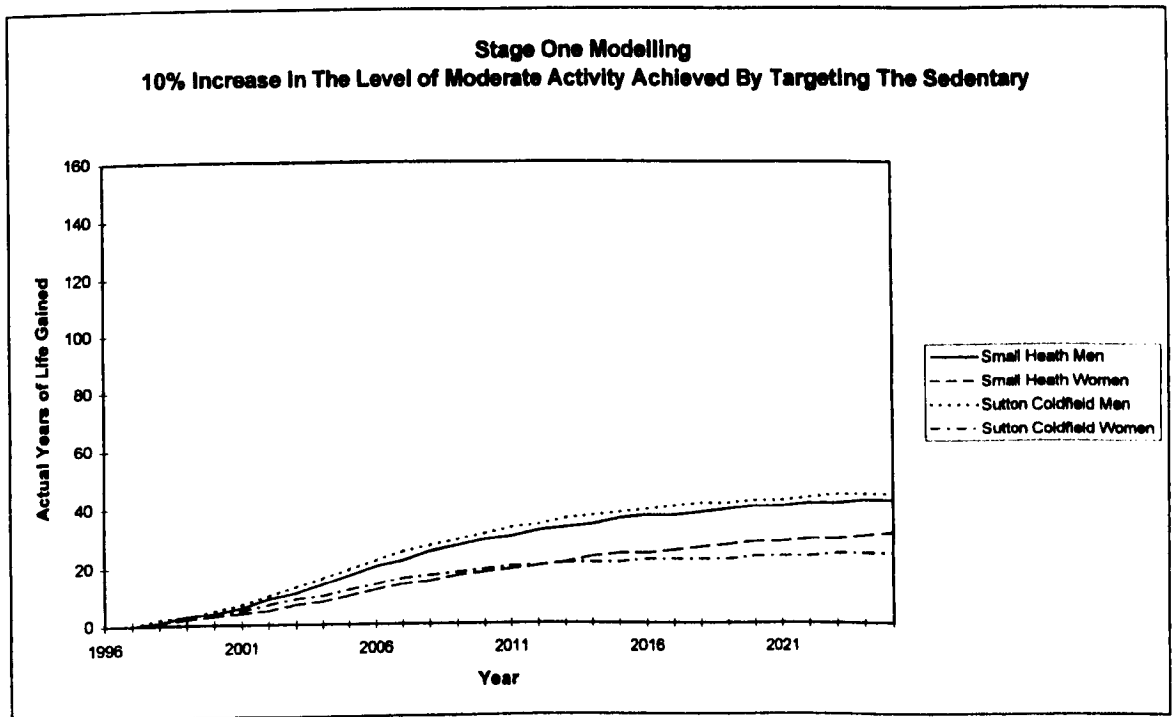

Figure 8.14 - Actual years of life gained due to a 10% increase in the levels of moderate activity achieved by targeting the sedentary in the Small Heath and Sutton Coldfield populations

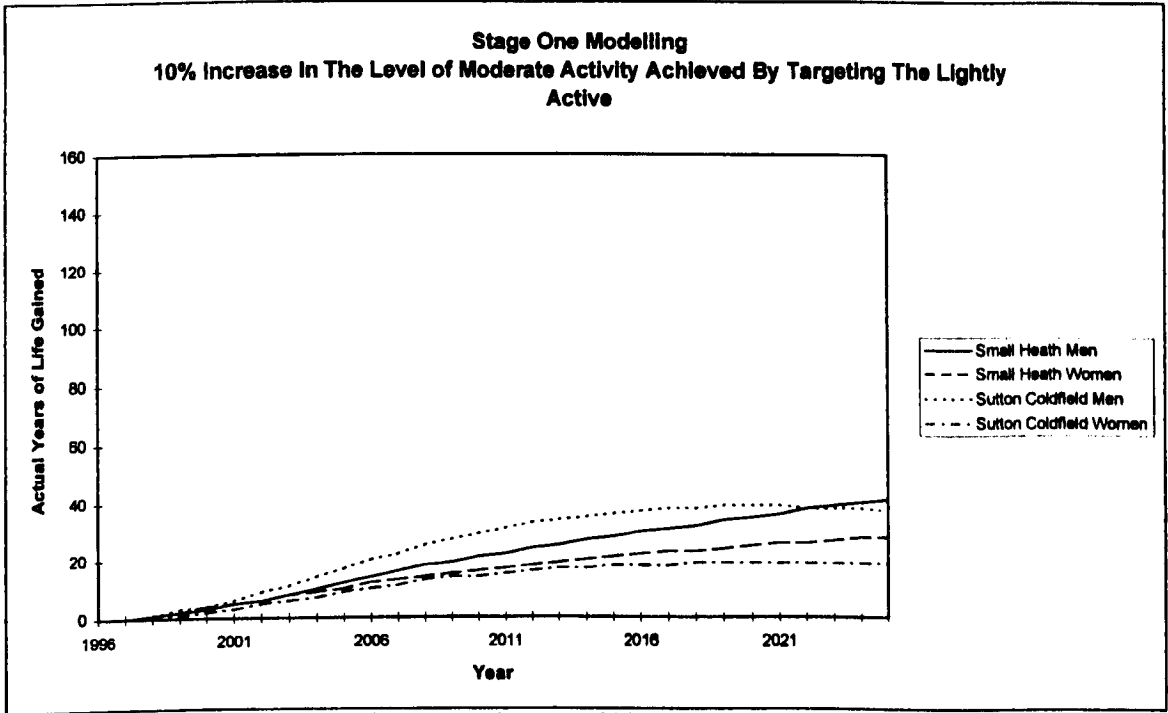

Figure 8.15 - Actual years of life gained due to a 10% increase in the levels of moderate activity achieved by targeting the lightly active in the Small Heath and Sutton Coldfield populations

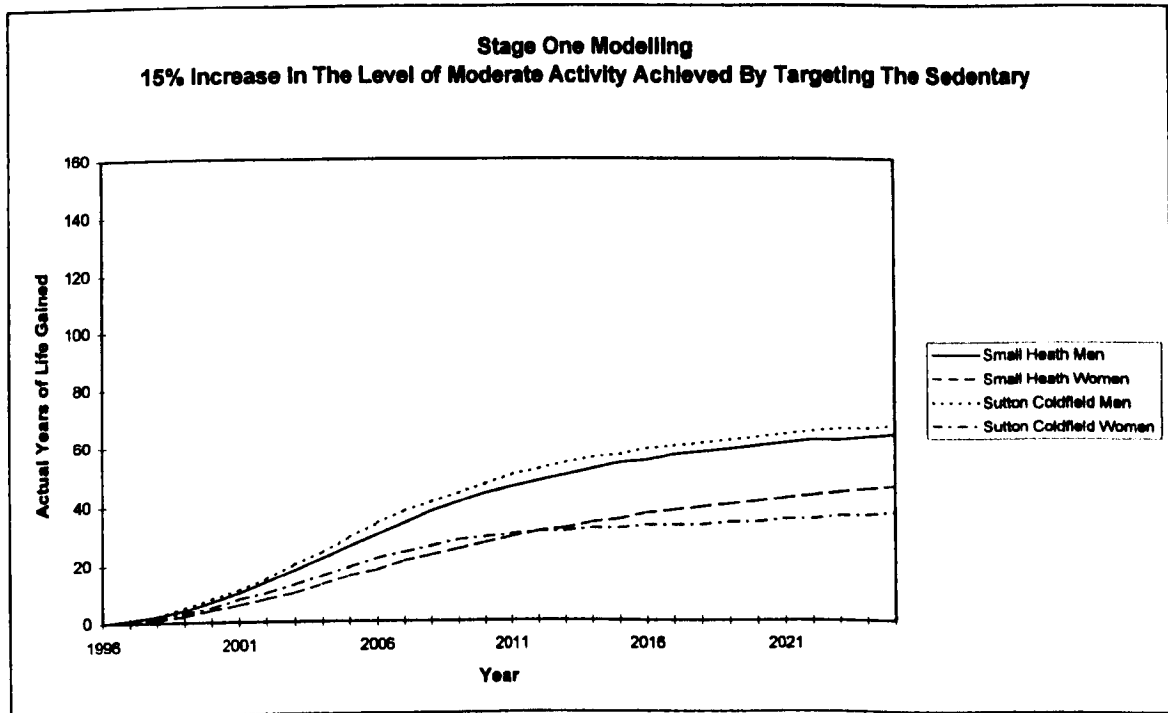

Figure 8.16 - Actual years of life gained due to a 15% increase in the levels of moderate activity achieved by targeting the sedentary in the Small Heath and Sutton Coldfield populations

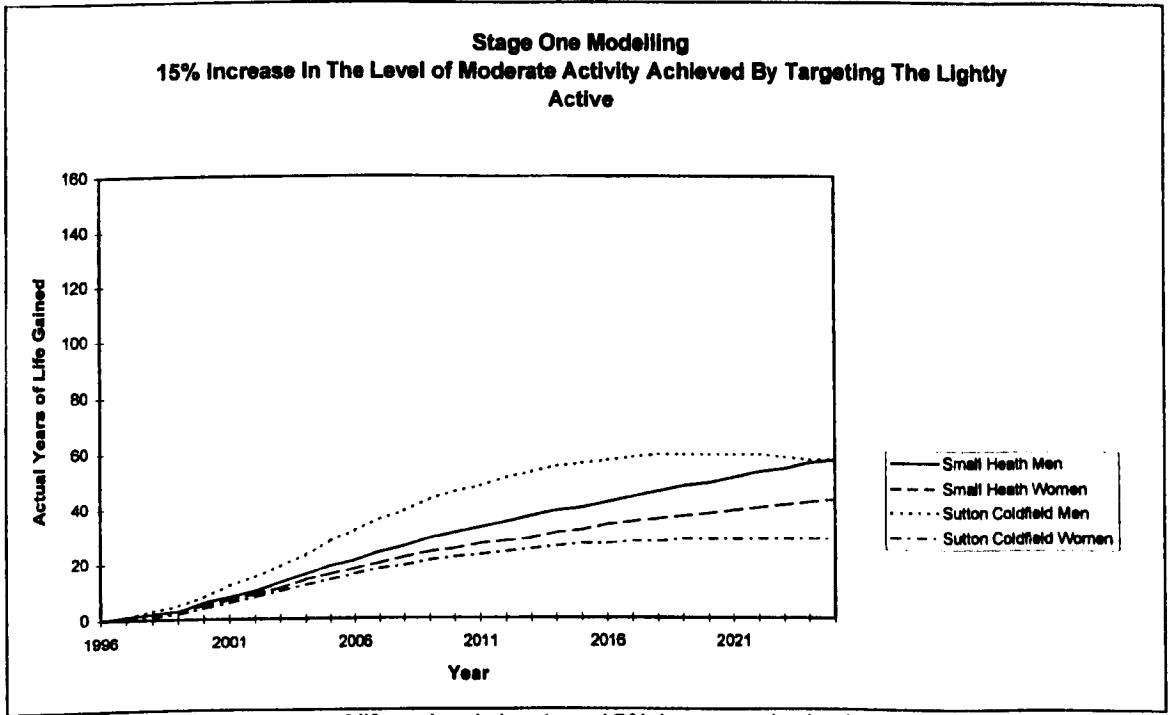

Figure 8.17 - Actual years of life gained due to a 15% increase in the levels of moderate activity achieved by targeting the lightly active in the Small Heath and Sutton Coldfield populations

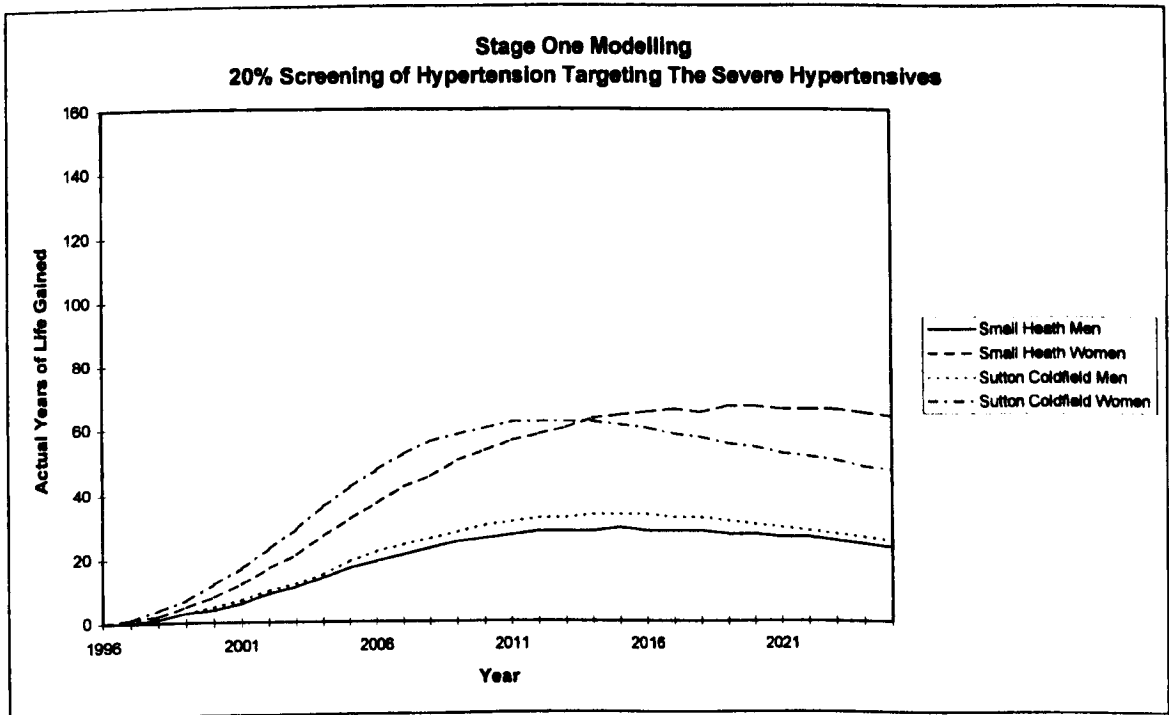

Figure 8.18 - Actual years of life gained due to a 20% screening and treating of hypertension targeting the severe hypertensives in the Small Heath and Sutton Coldfield populations

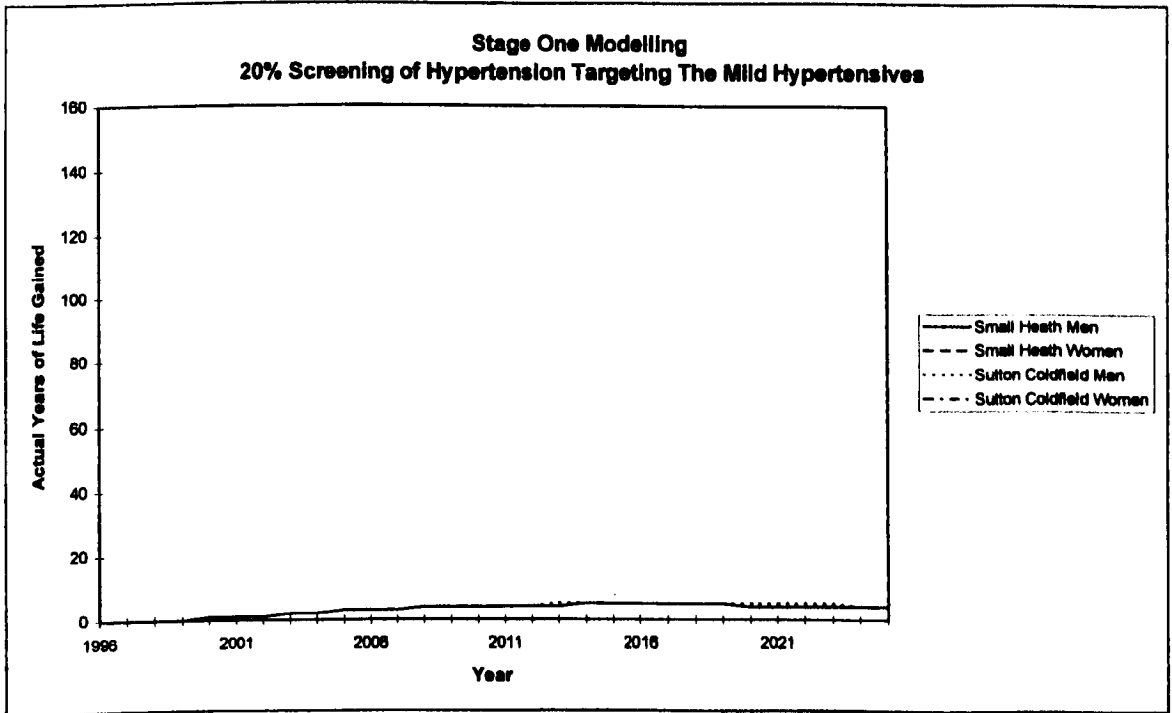

Figure 8.19 - Actual years of life gained due to a 20% screening and treating of hypertension targeting the mild hypertensives in the Small Heath and Sutton Coldfield populations

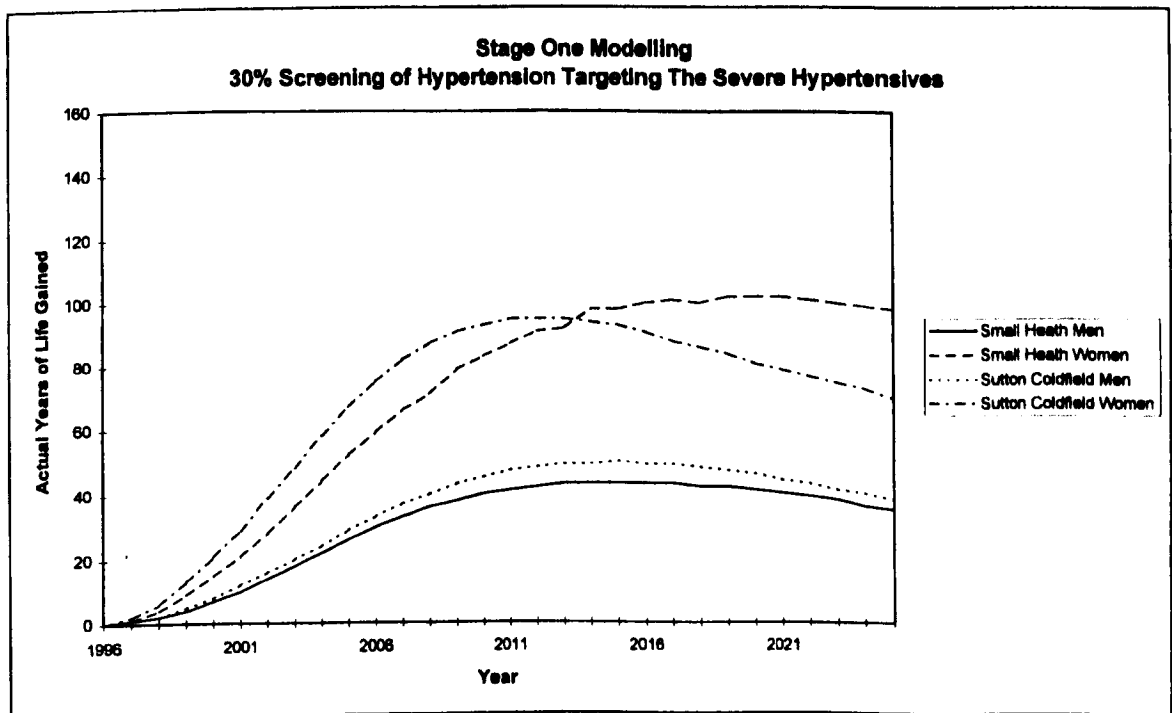

Figure 8.20 - Actual years of life gained due to a 30% screening and treating of hypertension targeting the severe hypertensives in the Small Heath and Sutton Coldfield populations

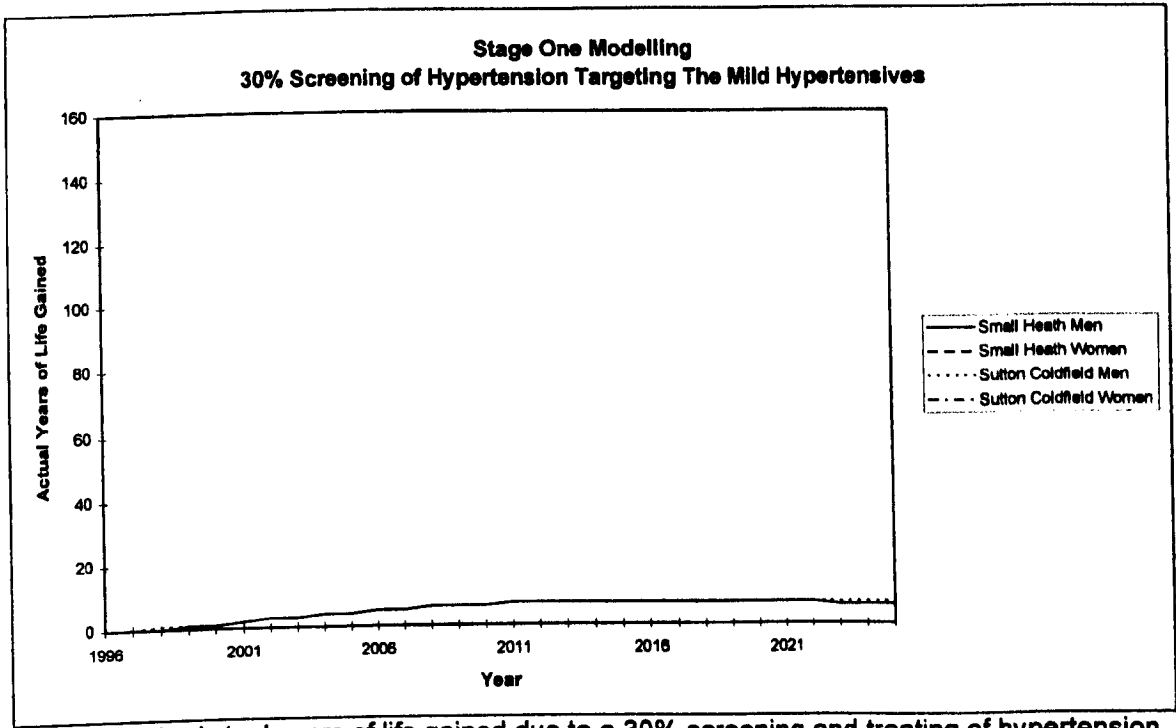

Figure 8.21 - Actual years of life gained due to a 30% screening and treating of hypertension targeting the mild hypertensives in the Small Heath and Sutton Coldfield populations

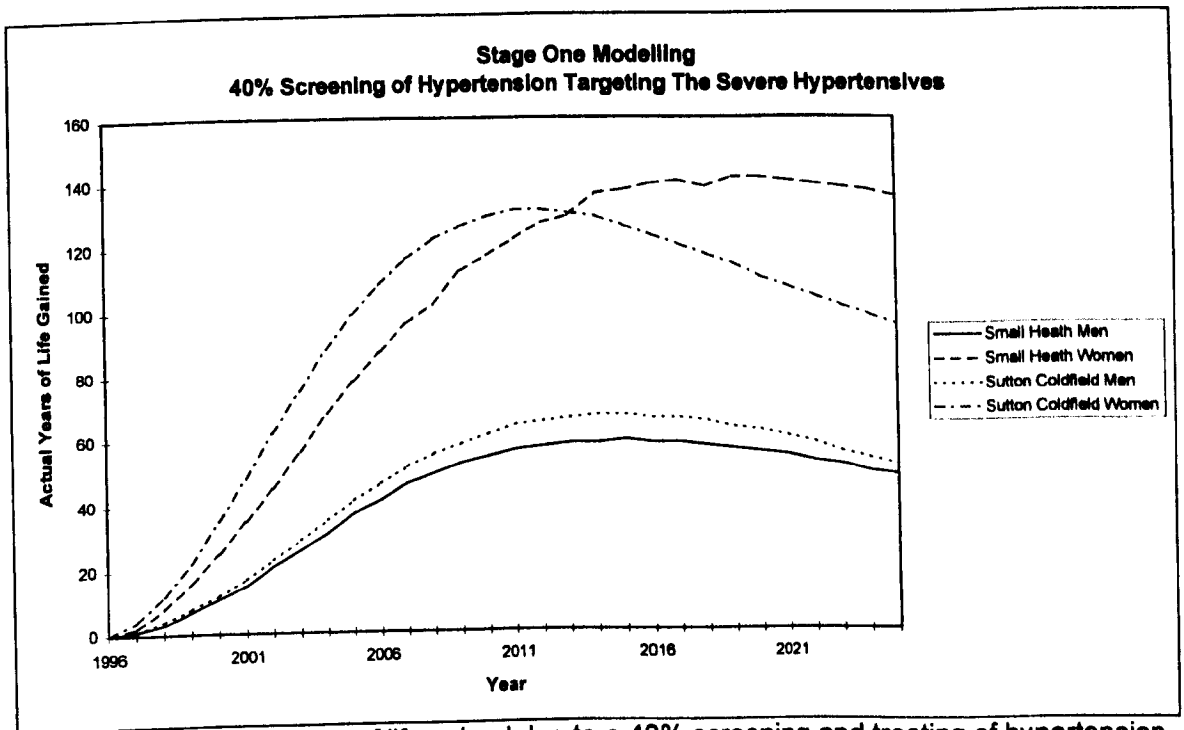

Figure 8.22 - Actual years of life gained due to a 40% screening and treating of hypertension targeting the severe hypertensives in the Small Heath and Sutton Coldfield populations

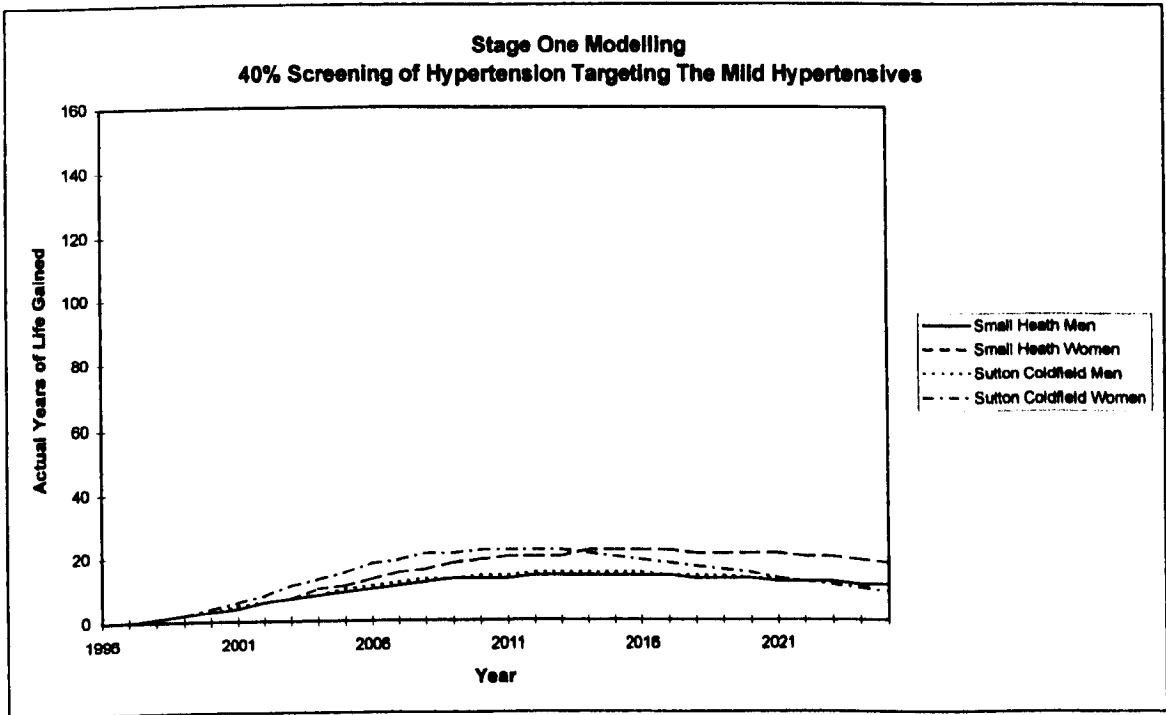

Figure 8.23 - Actual years of life gained due to a 40% screening and treating of hypertension targeting the mild hypertensives in the Small Heath and Sutton Coldfield populations

8.8 Discussion

Although the various interventions target differing percentage of the population; in terms of the ones that results in the most actual years of life gained for all three populations targeting sedentary males and severely hypertensive females appear to be the most effective interventions.

Targeting sedentary males, with a 15% increase in the prevalence of moderate physical activity, resulted in 724 actual years of life gained for the Birmingham population, 64 for the Small Heath population and 67 for the Sutton Coldfield population. These would be equivalent to the actual years of life gained achieved by 8%, 10% and 11% reductions in the prevalence of cigarette smoking in each population respectively.

Targeting severely hypertensive females, using the 40% screening strategy, resulted in 1226 actual years of life gained for the Birmingham population, 141 for the Small Heath population and 131 for the Sutton Coldfield population, and these would be equivalent to the actual years of life gained achieved by 23%, 35% and 63% reductions in the prevalence of cigarette smoking in each population respectively.

In terms of the comparison of the effect of the interventions between the Sutton Coldfield and Small Heath populations the numbers of actual years of life gained by each intervention were very similar due to both populations being of a roughly similar size. The Small Heath population gained more actual years of life due to the smoking interventions since there was a higher prevalence of smoking in this population than the Sutton Coldfield population. While for the physical activity interventions the Sutton Coldfield men gained more years of life than the Small Heath men due to the larger number of older men (over 30 years of age) in the Sutton Coldfield population, but the Small Heath women gained more years of life than the Sutton Coldfield women due to higher prevalence of sedentary women in the Small Heath population. As for the hypertension screening and treating interventions, Sutton Coldfield men achieved slightly more actual years of life gained than Small Heath men again due to the larger number of older men in the Sutton Coldfield population, while Small Heath women achieved more actual years of life gained than Sutton Coldfield women and this was achieved after a longer period of time due to the difference in population structure with more younger women (under 31 years of age) in the Small Heath population, and hence the effects are seen later.

8.9 Presentation of Results to Birmingham Health Regional Authority

These results were presented by me to Dr Chambers and Mr Harris, along with their General Practitioner group at the Birmingham Regional Health Authority.

Overall the GPs found the information fascinating, and were interested in seeing how interventions and targeting strategies within specific populations could be compared using a computer model. In particular they felt that the results of such models would be an incentive for GPs in that it gave them an idea of the magnitude of the effect of their interventions on individuals when aggregated to the population, and hence gave them a sense of their interventions being worthwhile. They were quite surprised by there being a small number of actual years of life gained over 35 years when the interventions were applied at the constituency level, but I explained that this was a result of the populations

being so much smaller than that of the whole of Birmingham. In addition, they thought that modelling could be used for risk factor management guidelines that could be developed for the city.

The GPs main concerns were that ethnicity was not included, particularly with 25% of the Birmingham population belonging to a ethnic minority group, and that there were no measures of morbidity, such as for non-fatal disease since they felt that just measuring mortality underestimated the effect of the interventions. They also thought that some quality of life measure would have been appreciated. I explained to them about the methodological and data problems connected with fitting ethnicity into the Prevent model, which made them aware of the lack of health data by ethnic group. I explained that Prevent was only designed for output in terms of mortality, and that the resulting simulation runs will always underestimate the possible health gain achievable because they do not take account of the effects of interventions on morbidity.

In terms of the interventions that I modelled the GPs raised concerns about whether the smoking interventions were smaller than the observed trend in the population, however they had no idea what the observed trend was in the Birmingham population, or if this trend had been measured, which it had not. So I explained that for the next stage of the modelling we would have to make some assumptions on the likely size of the trend.

During the discussions it became apparent that different definitions for hypertension are being used by GPs in the Birmingham area. They were using the 1993 WHO guidelines (Subcommittee of WHO/ISM Mild Hypertension Liaison Committee 1993) of mild hypertension being classified as having a diastolic blood pressure between 90 and 105 mm Hg, and moderate and severe hypertension being classified as having a diastolic blood pressure above 105 mm Hg, while the Prevent hypertension categories and relative risks were based on 1983 WHO guidelines (WHO 1983). However, Dr Chambers and Mr Harris wanted to keep the original categories since they conformed more closely to the definitions in the Health Survey for England of hypertension being classified as having a diastolic blood pressure above 94 mmHg, and so were, in their

view, more relevant for addressing the issue of screening and treating existing untreated hypertension, thus allowing them to compare Birmingham with the national figures. Amongst the group, questions were raised about compliance in any intervention, and whether this should be taken account of before applying reductions in risk factor prevalences. I explained that in modelling the interventions I had assumed that the reductions achieved were due to complete compliance, but that one should consider what percentage of a population needs to be intervened on to produce the desired change in risk factor prevalence.

With respect to forming policy, they were most interested in terms of Birmingham hypertensive screening, envisaging that such modelling could be used to decided who is it most appropriate to refer and who should be referred back to primary care. They were also interested in investigating whether they should treat the “diagnosed but not treated hypertensives” rather than screening. With regard to these goals they became aware that data not currently available needed to be collected.

The GPs were also interested in the cost consequences of the interventions, and would have liked to have had some economic output to the model so they could investigate such areas as what would be the best buy for hypertensives, or what would be the effect of an intervention in terms of the avoidable cost to health care.

Having seen what types of interventions could be modelled with Prevent the group discussed other scenarios that they would like modelled. Concern was raised about the growing prevalence of teenage smoking in Birmingham, and an interest was expressed in simulating what would happen if young people did not give up smoking like the older people. There was also interest in modelling reductions in cholesterol in a similar fashion to the hypertension interventions.

The GPs also expressed interest in modelling interventions concentrated on secondary disease, in particular for coronary artery disease and interventions on cholesterol,

smoking and blood pressure, as well as using aspirin, and so they were disappointed that Prevent could only model primary prevention.

In addition, I raised my concerns about the data on physical activity for Birmingham and its constituencies since they showed a marked difference from those for England & Wales, with particularly high levels of moderate and vigorous physical activity at older age groups (see Appendix F). It was agreed that these data were probably not that reliable. Consequently it was decided not to include physical activity in the next stage of the modelling.

At the end of the meeting Dr Chambers and Mr Harris had revised the areas they were interested in simulating to:

- the impact of smoking cessation in adults – simulating a stronger effect on smoking cessation with a year on year decrease in the prevalence, as well as taking into account the effect of background trends,
- teenage recruitment to smoking – since this was perceived as major health problem in Birmingham, and so they were interested in investigating the long term health consequences,
- interventions directed at hypertension.

STAGE TWO

8.10 Revised Specifications for the Modelling

Following further discussions between myself, Dr Chambers and Mr Harris; we decided to adjust the modelling scenarios to the following:

The impact of smoking cessation in adults:

- 0% background trend with -2%, -3% and -4% yearly reductions in smoking prevalence over 5 years from 1997;
- -3% background trend with -2%, -3% and -4% yearly reductions in smoking prevalence over 5 years from 1997.

Recruitment to smoking:

- 0% background trend with 1%, 2% and 3% yearly increases in the trend amongst the 15 to 24 age group from 1991 onwards.

Interventions directed at hypertension:

- 20% screening for untreated hypertension targeting treatment to the severe and then the mild hypertensives over 5 years from 1997;
- 40% screening of untreated hypertension targeting treatment to the severe and then the mild hypertensives over 5 years from 1997.

8.11 Simulations

As before the simulations were run for 34 years from 1991, but with the interventions beginning in 1997 and the target risk factor prevalences being achieved in 2005. The simulations then ran for a further 20 years, with risk factor prevalences at their new level, until 2025.

8.12 Results of the Modelling

8.12.1 Birmingham Simulations

As with the first model runs smoking interventions resulted in a greater number of actual years of life gained for males than for females, and as before the interventions had approximately twice the effect in males as in females (see Figures 8.24 and 8.25). Again for both males and females with each increase in the percentage reduction in the prevalence of smoking there was a stepwise increase in the actual years of life gained. With a background trend of minus 3% reducing the prevalence of smoking the interventions only produced approximately half the actual years of life gained as the scenario with no background trend, due to the background trend reducing the number of people who would be intervened on. This was the case for both males and females.

For the scenarios simulating the increase in smoking amongst 15 to 24 year olds there was no increase in disease specific mortality within the timeframe of the simulation for either males or females (Figures 8.26 to 8.29).

For the hypertension screening interventions, targeting the severe hypertensives resulted in a greater number of actual years of life gained for females than for males, over twice the number (Figures 8.30). As with the previous modelling targeting the mild hypertensives produced a much smaller effect, especially for females. Increasing the percentage of treated hypertensives resulted in a stepwise increase in the actual years of life gained.

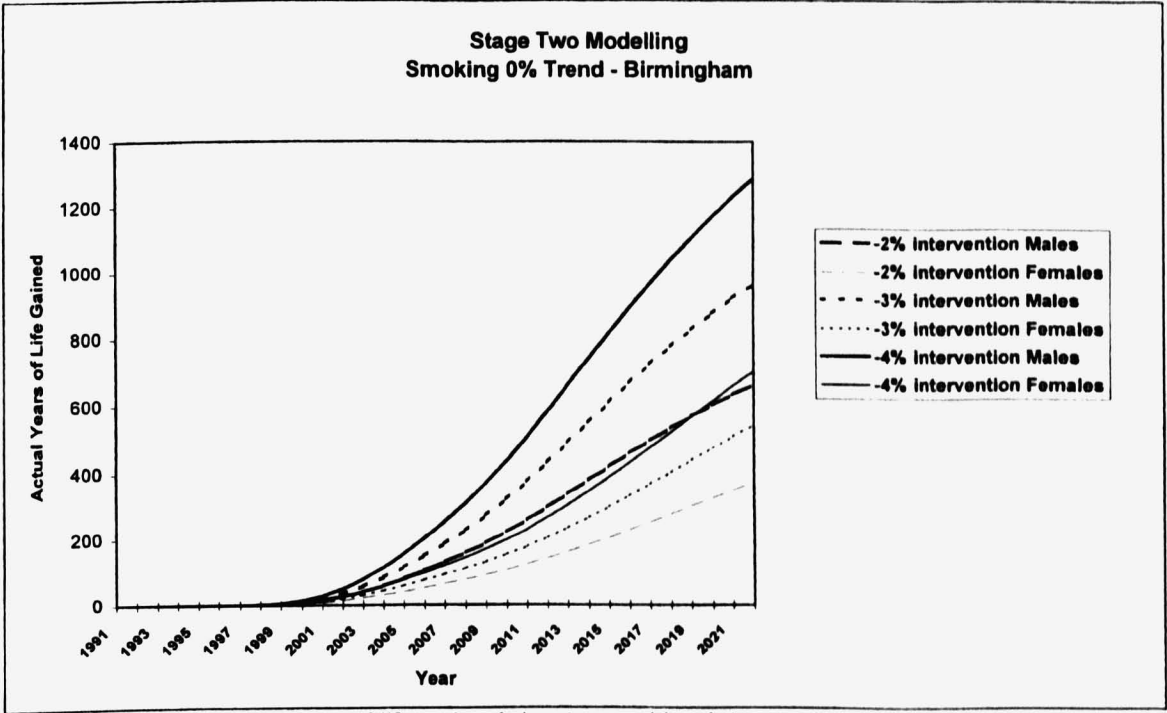

Figure 8.24 - Actual years of life gained due to smoking interventions with a 0% trend in the Birmingham population

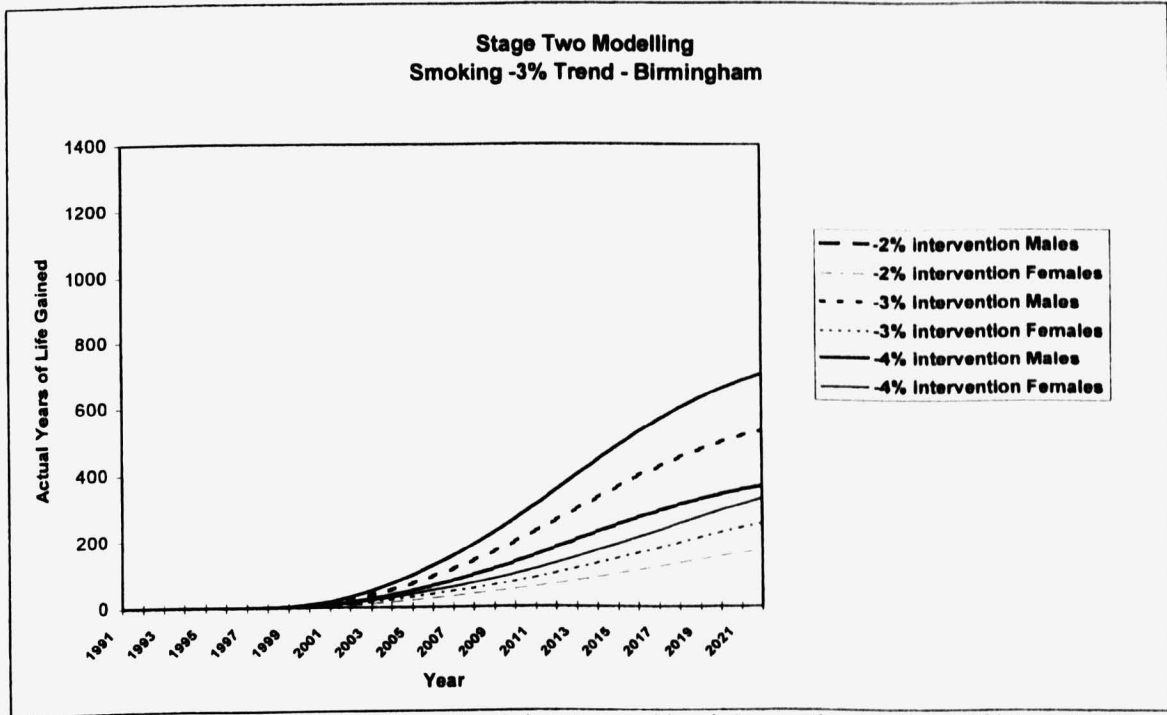

Figure 8.25 - Actual years of life gained due to smoking interventions with a -3% trend in the Birmingham population

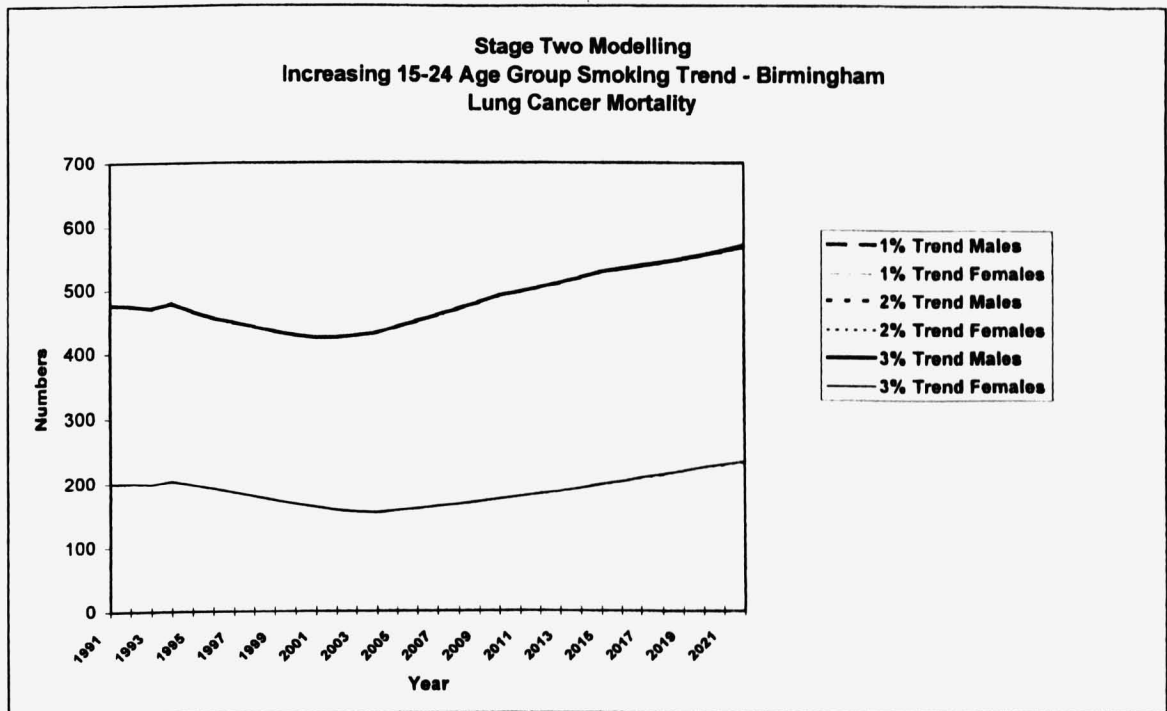

Figure 8.26 – Lung cancer mortality due to an increasing 15-24 age group smoking trend in the Birmingham population

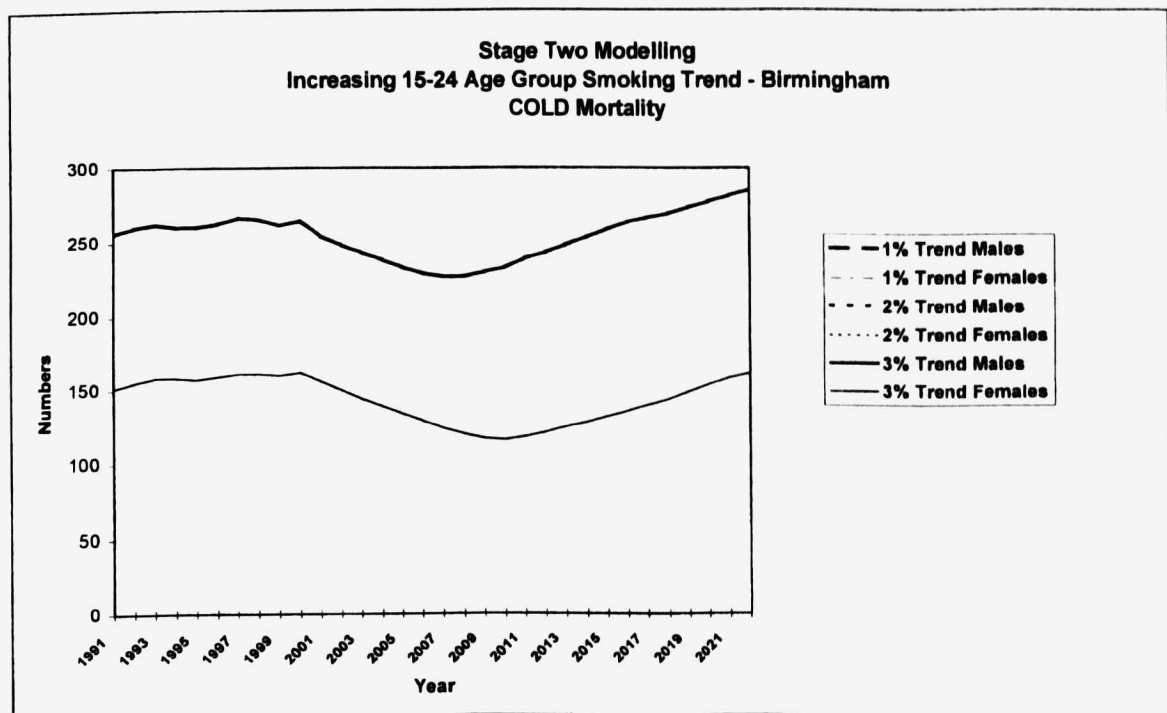

Figure 8.27 – COLD mortality due to an increasing 15-24 age group smoking trend in the Birmingham population

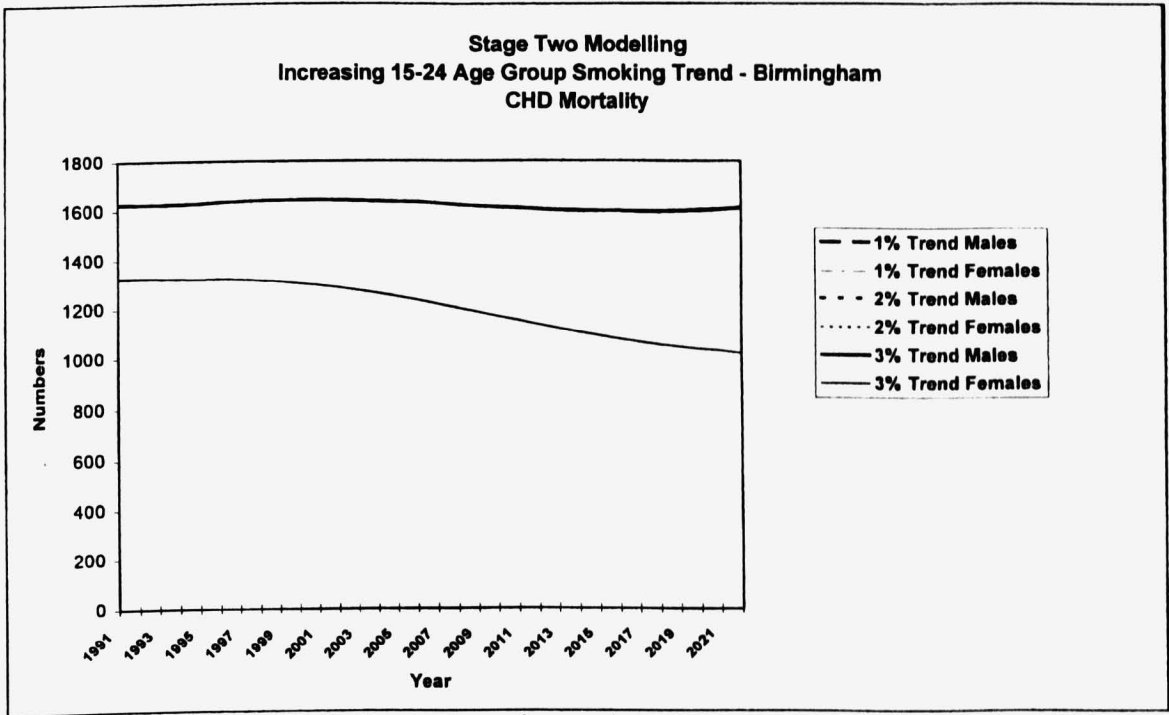

Figure 8.28 – CHD mortality due to an increasing 15-24 age group smoking trend in the Birmingham population

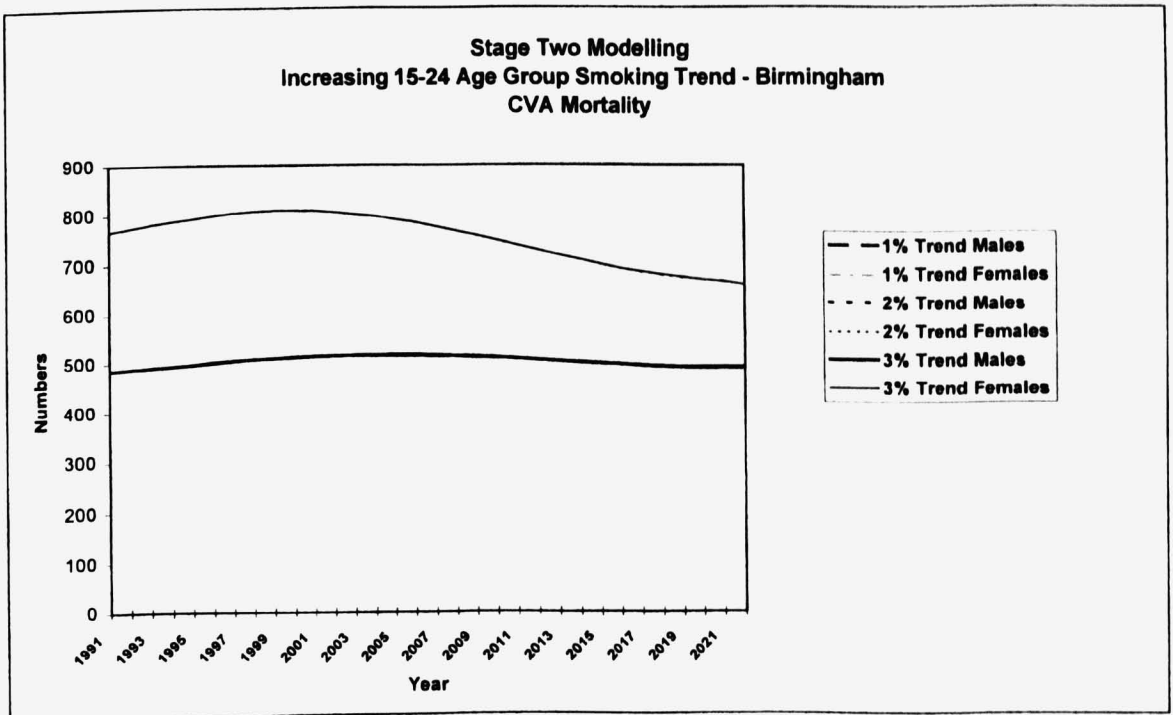

Figure 8.29 – CVA mortality due to an increasing 15-24 age group smoking trend in the Birmingham population

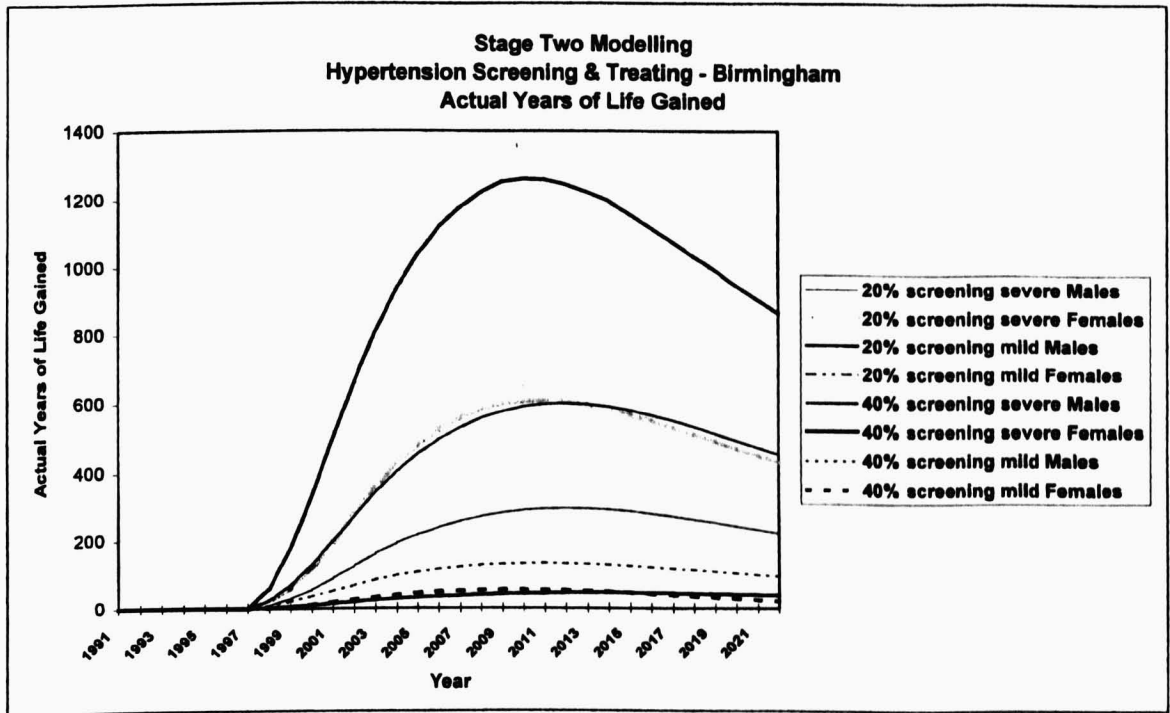

Figure 8.30 - Actual years of life gained due to screening and treating of hypertension in the Birmingham population

8.12.2 Small Heath and Sutton Coldfield Simulations

Again smoking interventions resulted in a greater number of actual years of life gained for males than for females, and were responsible for more actual years of life gained in the Small Heath population than the Sutton Coldfield population (see Figures 8.31 to 8.36). For all the interventions the number of actual years of life increased with each increase in the percentage reduction in the prevalence of smoking due to the interventions, and decreased with each increasing reduction in background trend in the prevalence of smoking. Although, as before, the number of actual years of life gained was very small for both populations.

Just as with the simulations for the Birmingham population there was no change in disease specific mortality due to increased smoking amongst 15 to 24 year olds of both sexes within the simulation period (Figures 8.37 to 8.40).

As with the Stage One modelling, hypertension screening interventions targeting the severe hypertensives resulted in a greater number of actual years of life gained for females than for males (Figures 8.41 and 8.42). While targeting the mild hypertensives

again had little effect, particularly amongst females. Similarly amongst males the interventions were responsible for more actual years of life gained in Sutton Coldfield than in Small Heath, while for females there were a greater number of actual years of life gained amongst those in Small Heath, reaching about 140 years of life gained by 2016, for 40% screening, and then levelled off, compared to those in Sutton Coldfield, which peaked in 2011 and then began to fall.

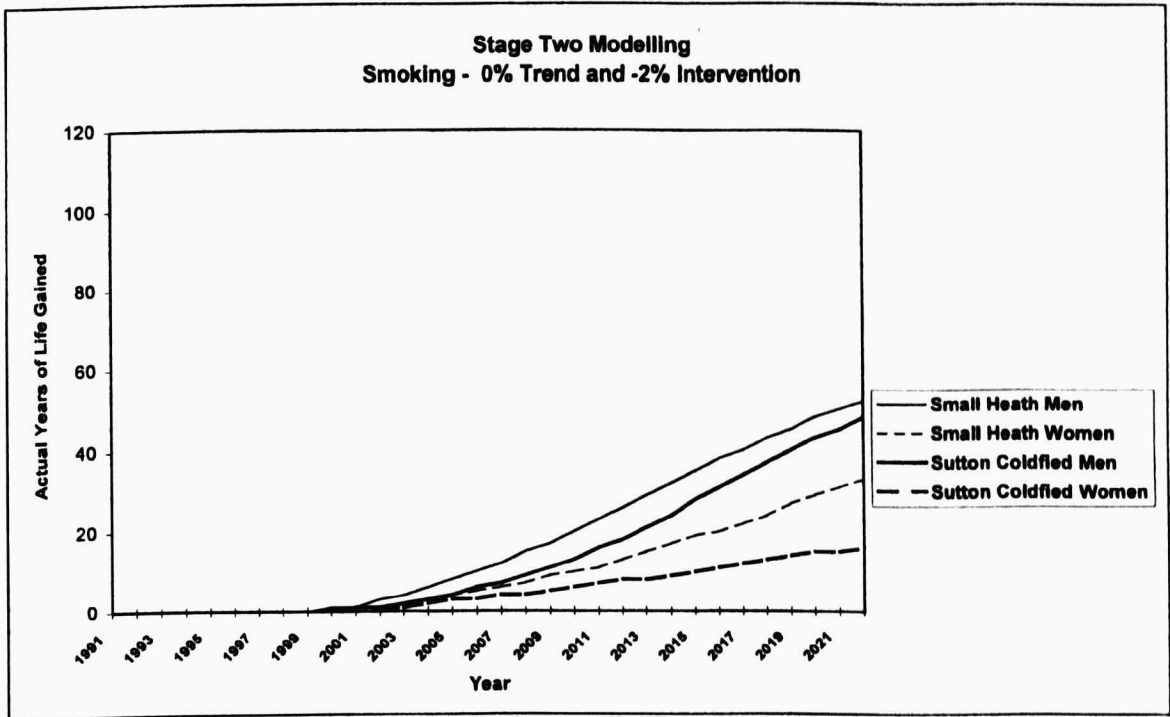

Figure 8.31 - Actual years of life gained due to a -2% reduction in smoking with a 0% trend in the Small Heath and Sutton Coldfield populations

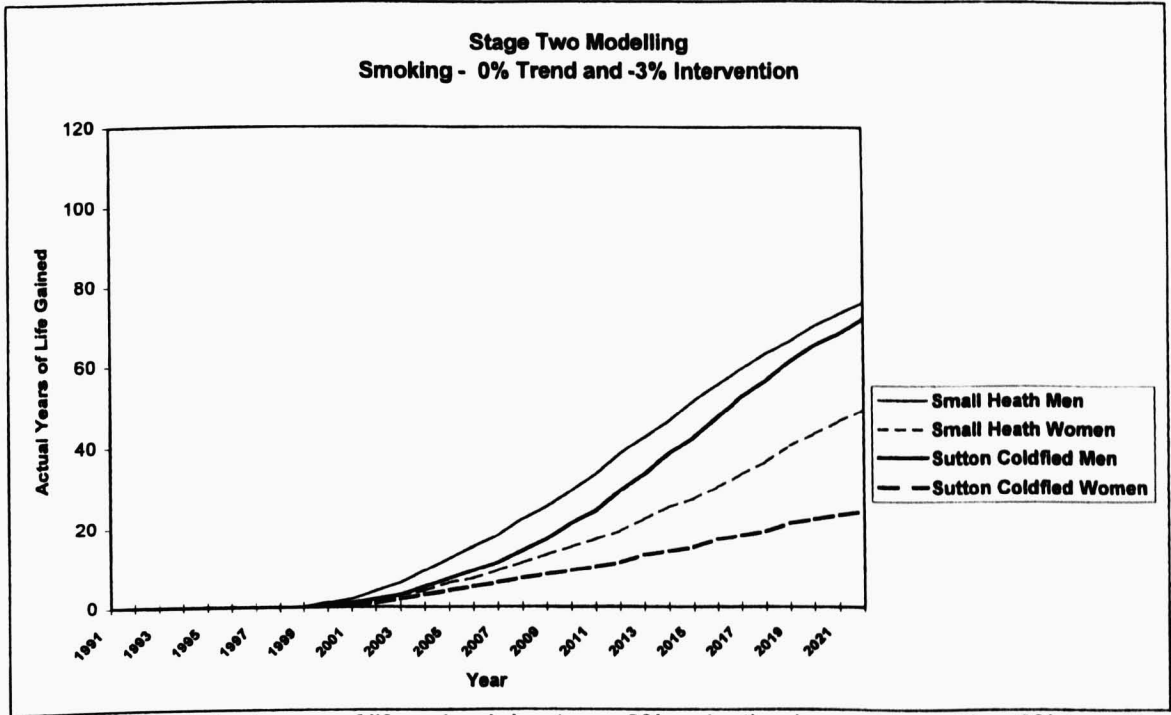

Figure 8.32 - Actual years of life gained due to a -3% reduction in smoking with a 0% trend in the Small Heath and Sutton Coldfield populations

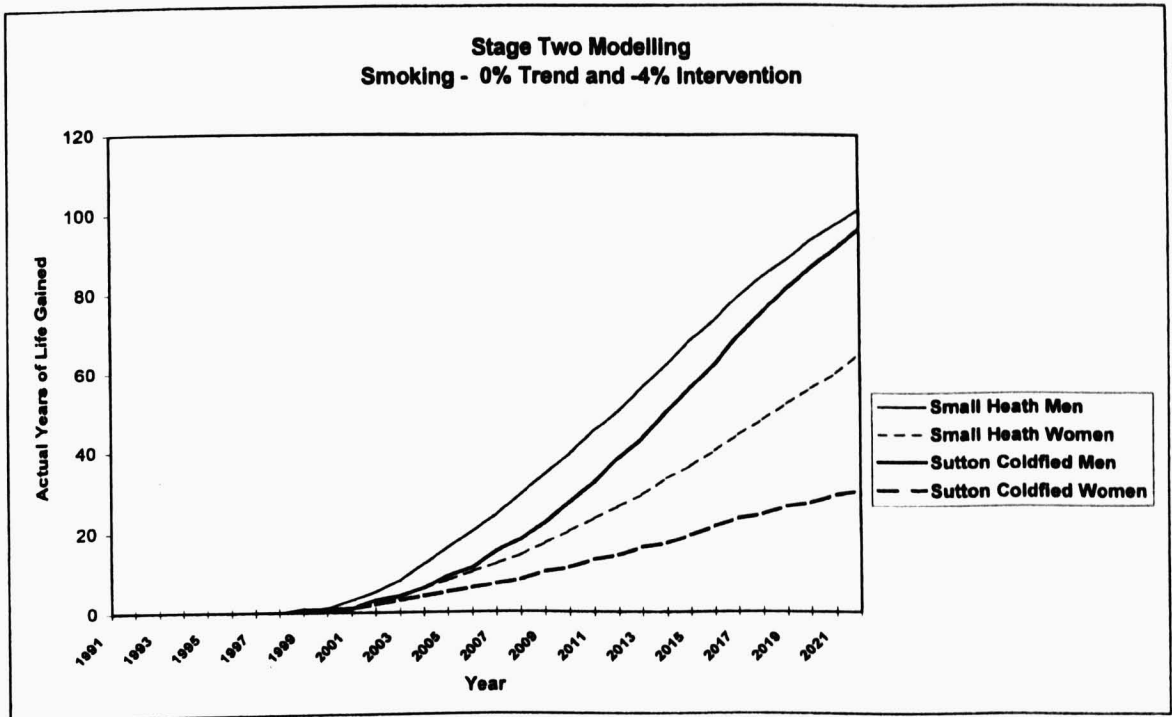

Figure 8.33 - Actual years of life gained due to a -4% reduction in smoking with a 0% trend in the Small Heath and Sutton Coldfield populations

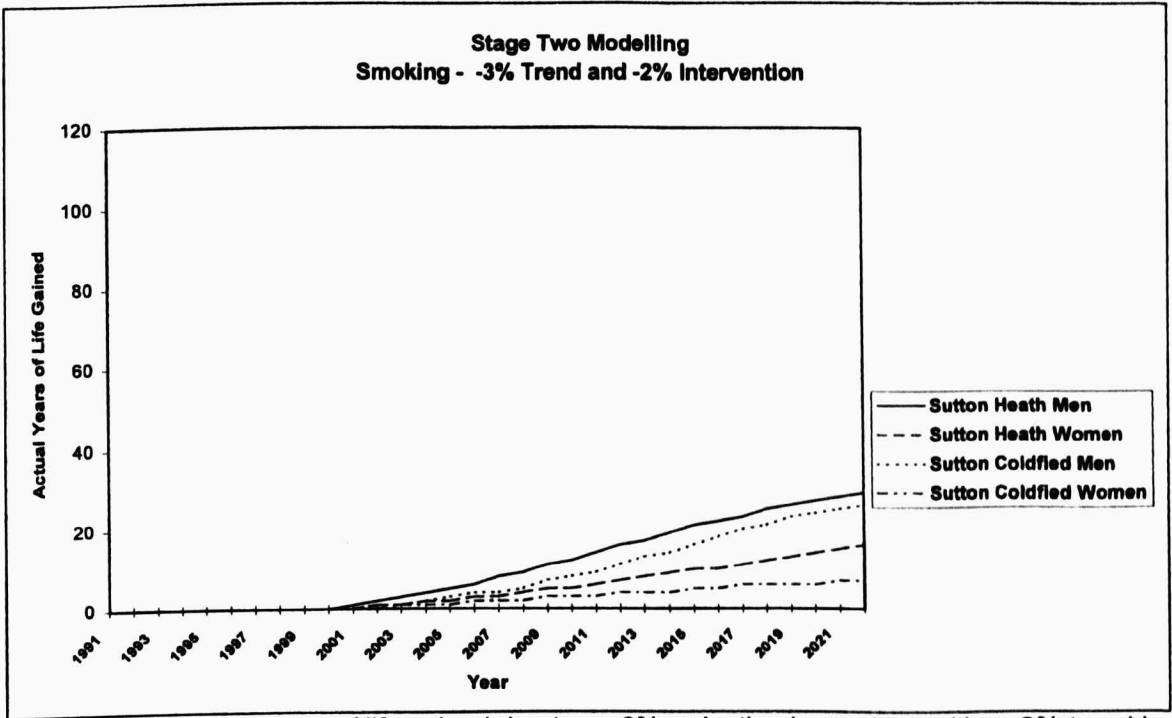

Figure 8.34 - Actual years of life gained due to a -3% reduction in smoking with a -2% trend in the Small Heath and Sutton Coldfield populations

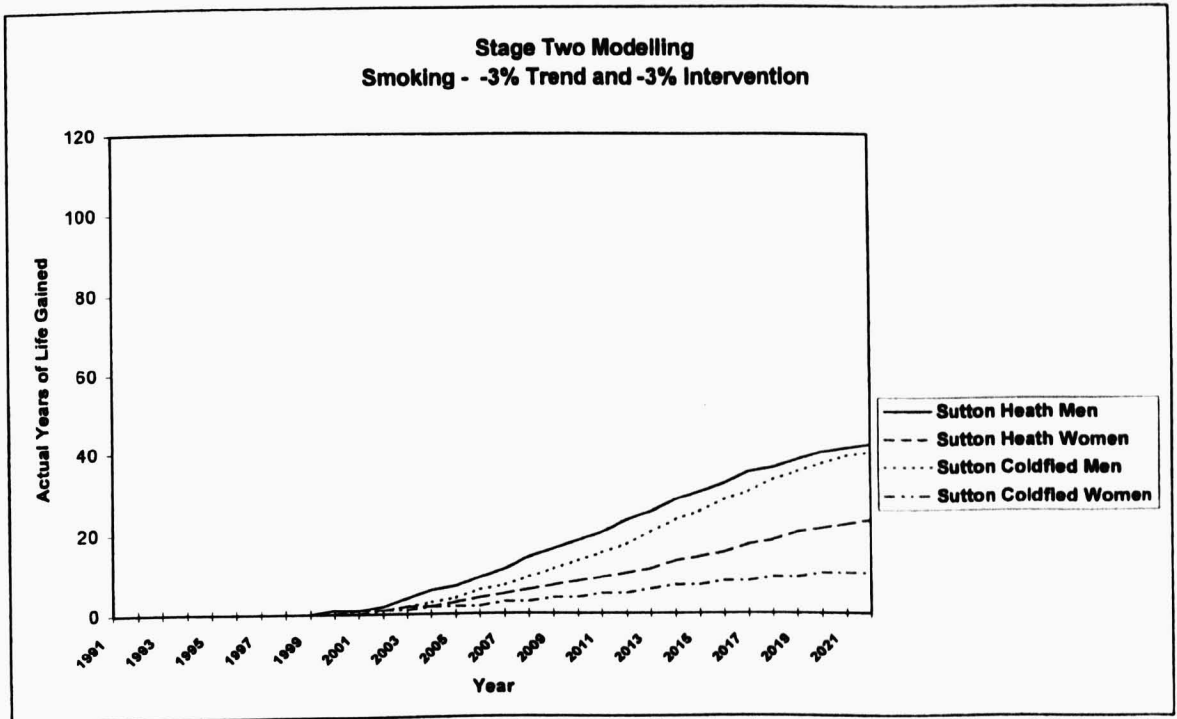

Figure 8.35 - Actual years of life gained due to a -3% reduction in smoking with a -3% trend in the Small Heath and Sutton Coldfield populations

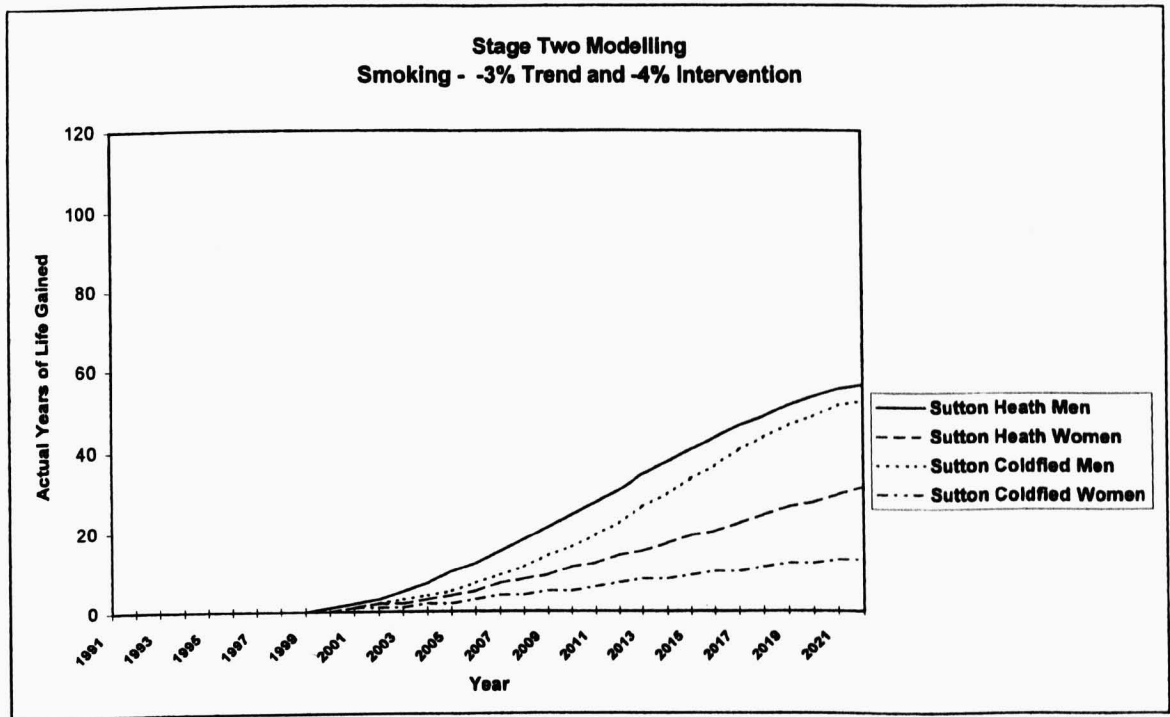

Figure 8.36 - Actual years of life gained due to a -4% reduction in smoking with a -3% trend in the Small Heath and Sutton Coldfield populations

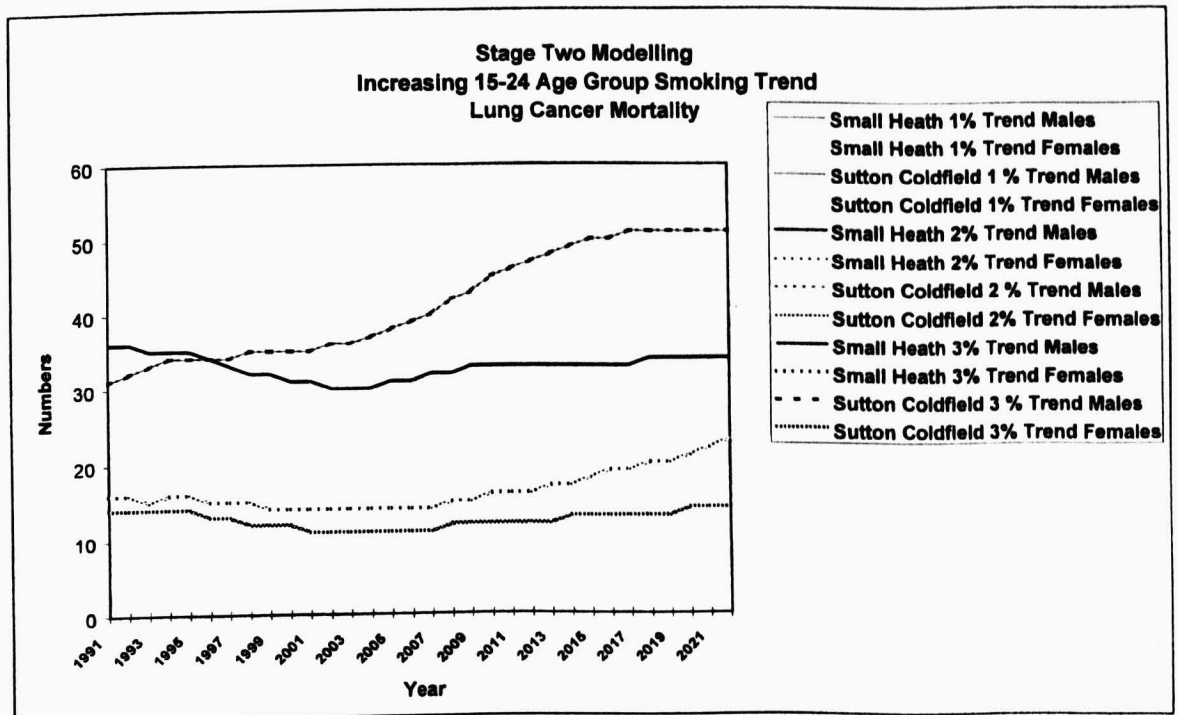

Figure 8.37 - Lung cancer mortality due to an increasing 15-24 age group smoking trend in the Small Heath and Sutton Coldfield populations

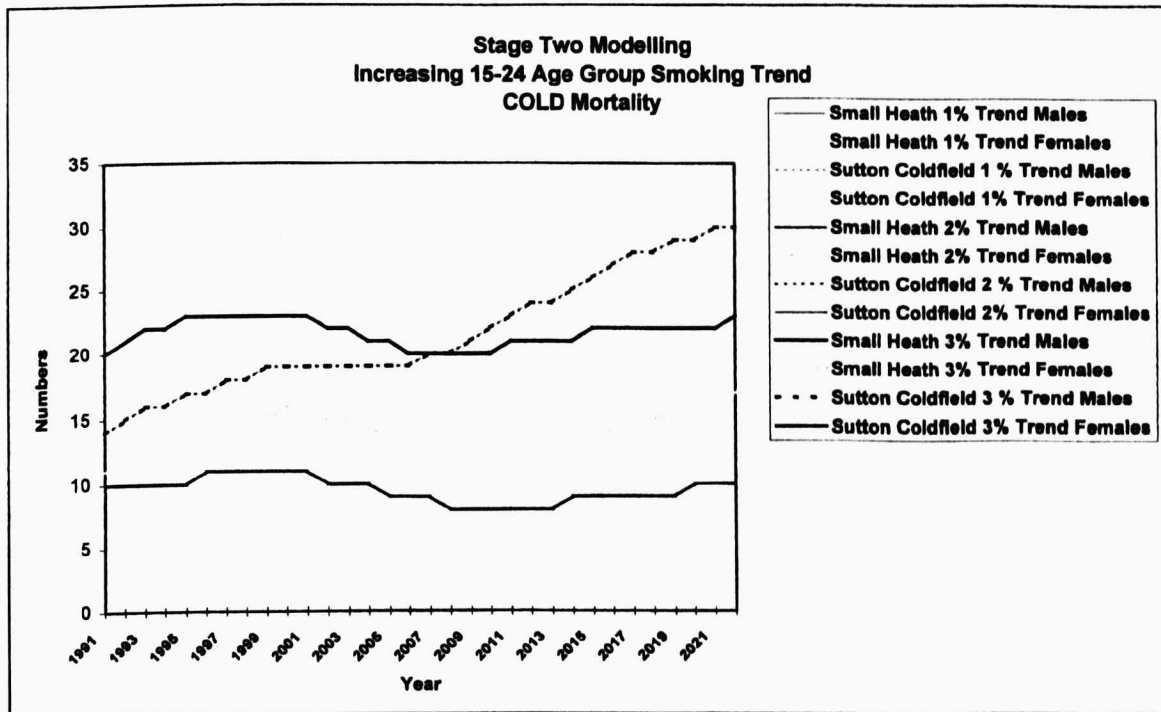

Figure 8.38 - COLD mortality due to an increasing 15-24 age group smoking trend in the Small Heath and Sutton Coldfield populations

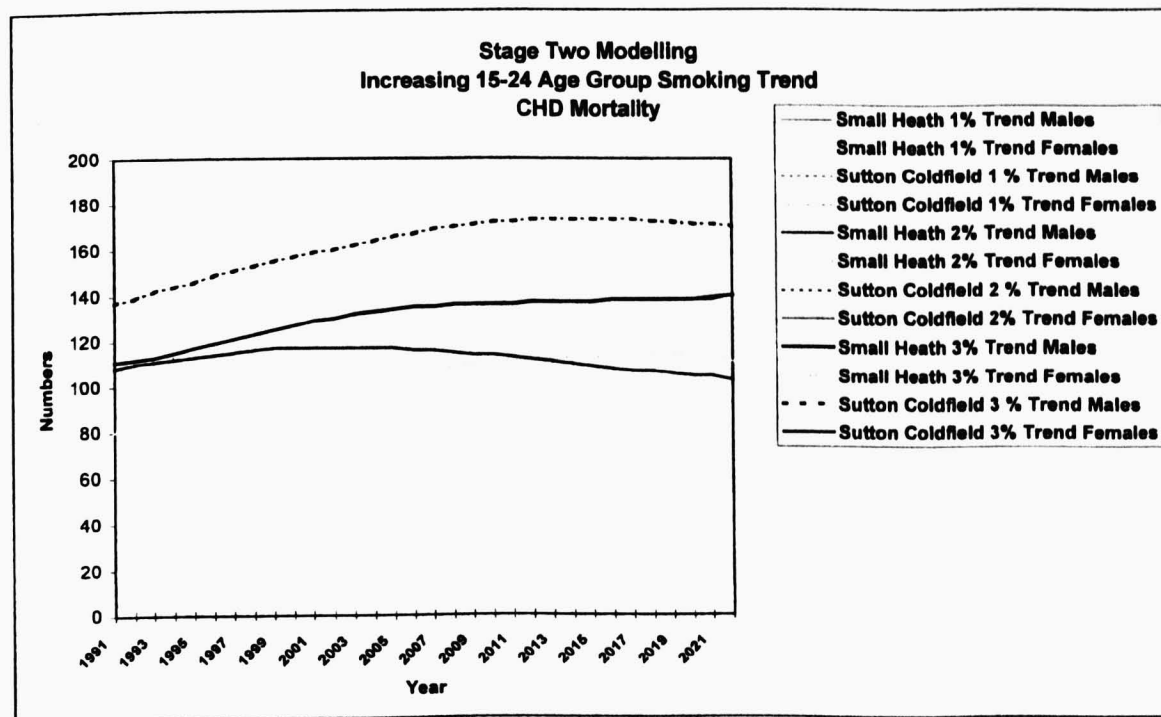

Figure 8.39 - CHD mortality due to an increasing 15-24 age group smoking trend in the Small Heath and Sutton Coldfield populations

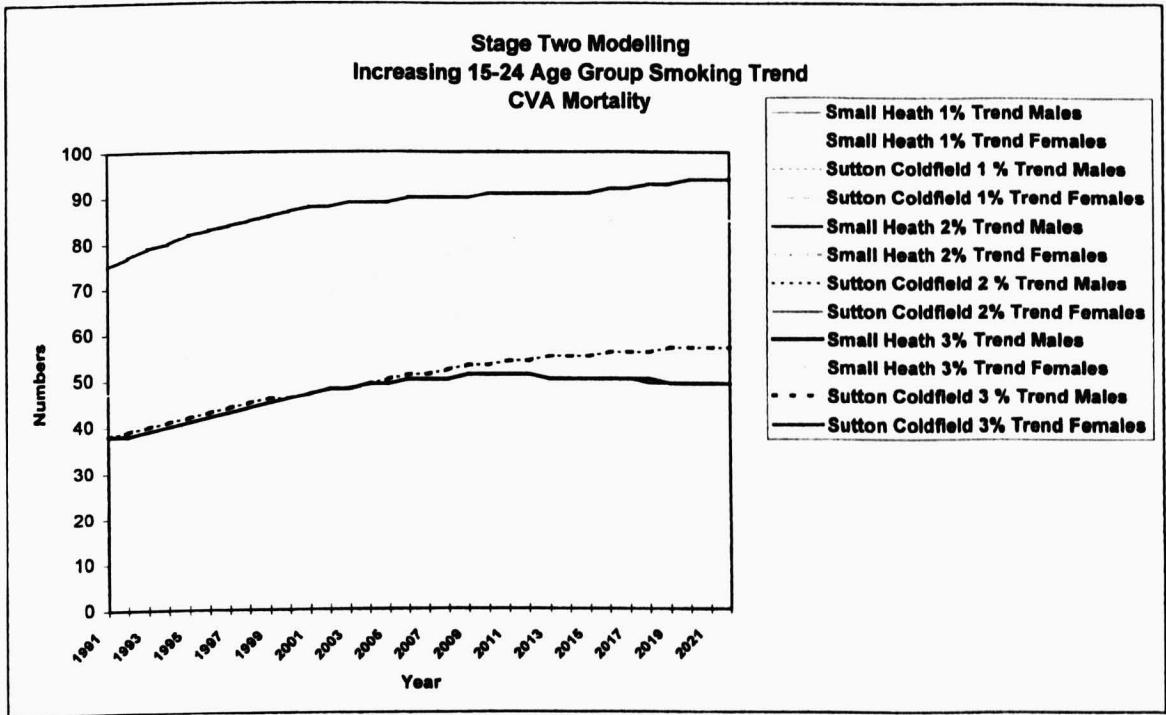

Figure 8.40 - CVA mortality due to an increasing 15-24 age group smoking trend in the Small Heath and Sutton Coldfield populations

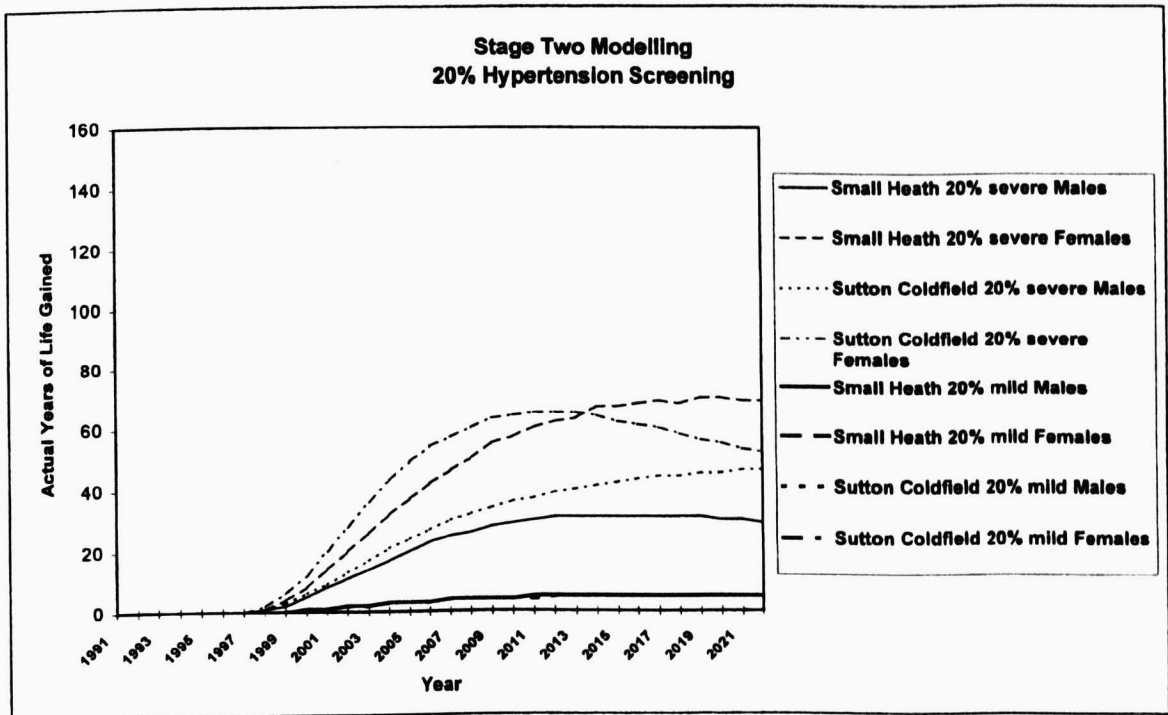

Figure 8.41 - Actual years of life gained due to a 20% screening and treating of hypertension in the Small Heath and Sutton Coldfield populations

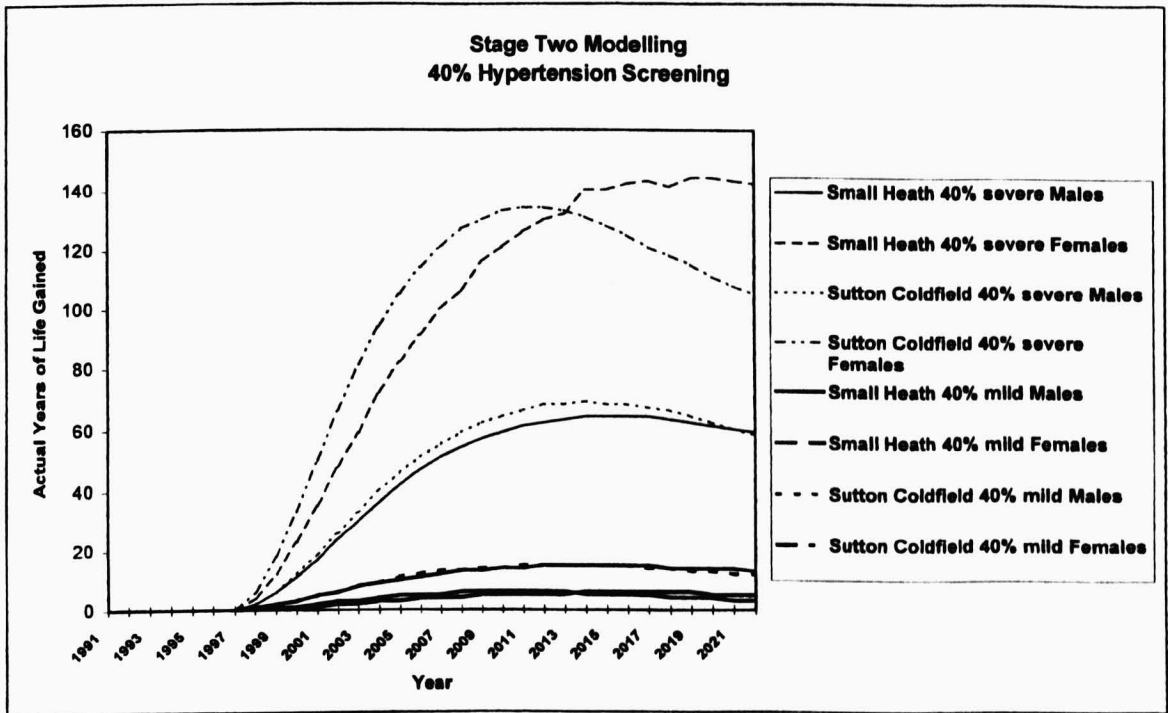

Figure 8.42 - Actual years of life gained due to a 40% screening and treating of hypertension in the Small Heath and Sutton Coldfield populations

8.13 Discussion

In terms of the interventions that results in the most actual years of life gained for all the populations targeting smoking males, and screening and treatment of severely hypertensive females appear to be the most effective interventions.

Dr Jackie Chambers' views were that she thought modelling risk factor interventions in the Birmingham population was a useful exercise, particularly with regard to the population focus of the model rather than targeting individuals, and the way that models translate health promotion strategies into deaths avoided.

She was concerned with the model's inability to take into account aspects of the local population structure other than age and sex, particularly my not being able to include ethnicity in the model. However, the discussions around the problem of trying to include ethnicity in the model highlighted the absence of data on risk factor prevalence and mortality by ethnic group within the Birmingham area.

She also felt that the lack of any morbidity measures was a weakness of the model, since just concentrating on the effect of interventions in terms of mortality greatly underestimated the possible health gain achievable.

In addition, Dr Chambers would have wanted the model to be able to simulate the delivery of secondary prevention strategies in primary care, particularly with regard to interventions on cholesterol, smoking, blood pressure, and using aspirin for individuals with CHD, thus taking into account of the ability of GPs to deliver the such intervention.

What she found the results of the modelling most useful for was arguing for resources at a Health Authority level. She had used the estimation that treating hypercholesterolaemia with statins at the 3% risk level would cost Birmingham Regional Health Authority £18 million and save 176 lives per year, compared to her interpretation of the modelling results of reducing smoking by 2% per year would save 170 lives per year in the medium term (actually it resulted in 194 years of life gained by 2007), and they were currently spend £0.3 million per year on that. So the results were used to justify the continued spending on their smoking reduction programme, rather than channelling spending elsewhere.

In terms of the future development of the model Dr Chambers thought that the model needed to include data on the effectiveness of health promotion, with regard to what proportion of a population needs to be targeted to achieve the modelled changes in risk factor prevalence, as well as data that gives the impact (uptake x efficacy) of the interventions.

8.14 Reflections

Overall I felt that the modelling work was an interesting and worthwhile exercise, since I feel that models such as Prevent are often developed and used by a modeller in isolation from actual policymakers, with the modellers and public health researchers

building models and simulating intervention that they think policymakers are interested in rather than what they actually want. This exercise gave me an invaluable opportunity to present modelling to policymakers, and to find out what issues were important to them. It was a means of getting them to develop the interventions to be simulated, which in turn makes the results of the modelling more policy relevant.

I was surprised that the result of the modelling were viewed by the GPs in terms of being an incentive to continue with their current practices, or introduce new practices, because they saw the effect of translating interventions at an individual level to that of a population, I had previously just considered the results in terms of comparing interventions.

My main frustration with the work was the lack of data, particularly with regard to risk factor and mortality data by ethnic group, since this was an area of utmost importance to Birmingham Regional Health Authority. Even though there were practical difficulties with including ethnicity in Prevent, the fact that no relevant data existed meant that I could not even consider alternative approaches, as I had applied with the physical activity modelling at the national level, to overcome Prevent's limitations. I found it interesting that in spite of an issue being seen as so important to policymakers; no data had been collected on the baseline health characteristics of the Birmingham population by ethnic group. Data on the characteristics of the population as whole were also limited, with only a 35% response for the Pulse Survey. This lack of baseline data has wider implications with regard to the evaluation of health policies within the Birmingham population. It is not possible to properly evaluate the effect of an intervention without being able to measure the changes that have occurred. One of the unforeseen outcomes of this work was that those at Birmingham Regional Health Authority became more aware of the need for such data.

Policymakers can sometimes be unrealistic about the interventions requested to be modelled, as in the case of the smoking interventions, where I was asked to increase the change in prevalence due to the intervention since there was a perception that the

background trends in the population were greater than the intervention in my Stage One modelling. The background trends were increased to at least a 2% yearly reduction. On reflection this now seems overoptimistic since in California with very strict tobacco control policies and massive investment only a 1% yearly reduction was achieved (Glantz 1993). This has led me to realise the need for modellers to review the literature on the effectiveness of interventions, particularly with regard to the changes in risk factor prevalence due to an intervention that would realistically be achievable in a population. Modellers can advise policymakers rather than relying on those commissioning the modelling to dictate the changes in prevalence. In future before undertaking modelling such as this I would investigate through the literature what changes would be achievable by the intended interventions. However, this problem of overestimating the effectiveness of public health, or health promotion, interventions may be difficult to overcome due to the scarcity of experimental evidence (Winkelstein 1981) and the lack of evaluation of health promotion studies (Nutbeam 1998), as well as the problems of generalising results from studies conducted on different populations to one's own (Speller 1997).

It is important that modellers have information about the current practice of the people for whom they are modelling. In this work it would have been useful to model the 1993 WHO hypertension guidelines, as well as the Health Survey for England hypertension categories, since although the latter were relevant to the policymakers at Birmingham Regional Health Authority in terms of achieving targets; they were not relevant to the GPs in terms of their current practice. Modellers need to be aware that the seemingly same intervention in a population can be put into operation using different criteria by different groups, and that modellers may need to address the needs of each group separately.

In terms of choosing Prevent as the model to simulate the interventions I think that it was very suitable for simulating the interventions derived by Stage Two of the work. However, it is possible that if a different model had been used, different interventions would have been chosen, and that knowledge of the constraints on the model resulted in

our limiting the interventions to those that were possible with the model. The more flexible the model, the more varied the interventions simulated would have been. The main shortcoming in using Prevent was the lack of any morbidity output, since just reporting the effect of primary care interventions in terms of mortality is disappointing to policymakers with respect to the size of the health gain achieved, as well as the insights that can be gained.

8.15 Conclusions

Although Prevent has been used successfully in simulating risk factor interventions for relatively small populations such as that of the Netherlands (15 million); it had never been used for populations as small as Birmingham, Sutton Coldfield and Small Heath. My modelling has shown that even when using such small populations it is still possible to compare interventions, although the health gained achieved is small.

The modelling work has also illustrated how targeting the same risk factor intervention at populations which have the same risk factor prevalence, as with hypertension, will still produce differing outcomes in terms of health gain due to their differences in age/sex structure and mortality patterns.

One interesting aspect of this work has been how presenting results of “what if” interventions scenarios stimulated discussion about other aspects of health interventions that policymakers and practitioners were concerned with, and about how these interventions would be achieved, as well as highlighting the current lack of, and need for, accurate baseline data.

I was particularly interested in how Birmingham Regional Health Authority used the model for policy making. The output on smoking was used to back up an existing decision to allocate resources to smoking interventions in Birmingham, but the output on screening for untreated hypertension which showed potential for large gains was not acted on, since it was not on their policy agenda. This is a good example of one the

difficulties of turning research into policy, that in spite of the research showing a beneficial intervention; policymakers will only pick out the bits of the research that support the areas that they already see as important, rather than highlighting new areas for the policy agenda as would ideally be the aim of such modelling exercises. It shows that policy does not always follow the Rational Model (Walt 1994), as outlined in Chapter 3, in which the knowledge gained from research should drive the development of policy in a rational and linear process. Instead policymakers will pursue their own agenda, which may differ from that of researchers, or may only encompass a portion of their research. Ultimately policymakers may only use research that will help sustain their current policy agenda, and may not be receptive to research that will require a change in policy.

8.16 Summary

This chapter describes my work with Birmingham Regional Health Authority in adapting the Prevent model to produce versions for the Birmingham, Small Heath and Sutton Coldfield populations. It describes how these models have been used to make comparisons between risk factor intervention strategies targeting by age, sex and risk factor as a possible aid to policy decision making. In addition, the chapter outlines the process of how the interventions modelled were developed in conjunction with Birmingham Regional Health Authority, and details their feedback on the work.

Prevent proved to be a useful tool in comparing the effect of different interventions in the Birmingham populations, and in comparing the effect of the same interventions in different populations. It demonstrated its ability to make these comparisons even when simulating relatively small populations, although the health gain achieved may be modest.

In terms of using the model with policymakers the chapter details how important data are to the modelling process, particularly how, in the case of ethnicity, the lack of appropriate data meant that important policy issues could not be addressed. It also

illustrates how policymakers need to be informed on the effectiveness of interventions, otherwise they may ask for overoptimistic and unrealistic interventions to be simulated. In addition, the chapter highlights how modelling can be used in translating research into policy, showing that results of modelling can be used by policymakers to justify current policy decisions, while other modelling results may receive less attention.

Chapter 9 – PREVENT European Collaborative Project

9.1 Introduction

In the early 1990s a number of countries in Europe had developed, or had begun to use public health models. Epidemiologists in the Netherlands, the U.K., Denmark and Sweden had been using Prevent. However, this research had been carried out separately in each country, so common problems were being solved independently, causing a duplication of work, and was perceived as a barrier to progress. With the development of Prevent, and the emergence of other models such as NIMPH and POHEM, there was a growing need for an international forum to provide mutual support for modellers and for model users with various experiences, which would enhance the development and the use of modelling within Europe.

Discussions about the desirability of collaboration in modelling came to the fore at the 1994 Conference of the European Public Health Association in Copenhagen at a workshop on “*Prevent Models and Other Models.*” As a result of these initial discussions Professor Gunning-Schepers submitted a proposal, for which I wrote the technical section on existing public health models, to the European Unions’(E.U.) Biomed II concerted action programme entitled “*Public Health Models,*” which was accepted for three years of funding by the E.U., and work on the collaborative project began in 1996.

The four objectives of the collaboration which was funded were:

1. to validate the models in the context of different E.U. countries,
2. to compare the implementation, the utilisation and the results of Prevent in different E.U. countries,
3. the exchange of data, notably on risk factors, relative risks, new treatments and treatment outcomes, for inclusion in such models,

4. to explore some methodological issues, such as the comparison of various modelling techniques like cell-based modelling as opposed to micro-simulation modelling.

The project participants were members of the London School of Hygiene & Tropical Medicine, the University of Amsterdam, the University of Rotterdam, the Centre for Epidemiology – Sweden, the Centre For Studies in Health and Health Services – Denmark and Statistics Canada.

In this chapter I outline the Prevent related work of the project, concentrating on my own work with the Prevent model, as well as summarising the cross-country comparison modelling work carried out as a result of constructing the four comparable Prevent models. I discuss my work on the POHEM phase of the Biomed II project in Chapters 13 and 15.

9.2 Four E.U. Versions of PREVENT

The collaborative European project entailed producing versions of Prevent for the 4 E.U. countries involved (England & Wales, The Netherlands, Denmark and Sweden). Having set up these versions for Prevent, they were to be used for simulating identical risk factor interventions in each country to compare how the differing demographics and risk factor prevalences would affect the outcomes.

As described in Chapter 4 - Data Sources, the validity of computer simulation models' output depends not only on the methodology and the structure of the model, but also on the quality of the input data, and much of the work for this part of the project involved resolving issues of using the "best" available data for the model. The aim of this phase of the Biomed project was to construct four different country-specific Prevent models, but each with comparable data sets and the same relative risks applied. We made joint efforts to decide which risk factors to use and that involved searching the literature, with each country looking individually for the data that was available. This did not usually involve searching the literature, but rather consulting experts.

There were substantial cross-country differences in the data that were being used for Prevent and in available empirical data. Different ICD codes were being used in the definitions of disease, for example we had to decide whether our definition of CHD would include “ill defined descriptions and complications of heart disease” (ICD9:429). In addition, risk factor prevalence data did not have the same amount of detail or cut-off points. For instance, in Sweden smoking was recorded at a national level as a dichotomous (yes/no) variable from 1989 onwards. Much of the effort of this phase of the project was spent trying to find the best compromise between uniformity in structure of the four countries’ data sets and the maximum use of the available data from each country.

Full details of all the input data are given in the final report of the Biomed project (Biomed II 1999).

9.3 Population Data

9.3.1 Base Year

This phase of the project began in 1996. Ideally, the base year should have been the most recent year for which population data were available, but it also had to be the same for each country. 1993 was chosen as the base year, since it was the most recent year that population data were available for the Netherlands, Sweden and Denmark, while for England & Wales it was the most recent year of the Health Survey for England, from which risk factor prevalence data would be extracted, that included the measurement of cholesterol.

9.3.2 General Mortality

There were cross-country differences in total mortality in the 0-1 year age group due to differences in the definition of total mortality, which included or excluded neonatal mortality. To keep the definition consistent across the four countries we decided to include neonatal mortality in the definition of total mortality. We chose to enter mortality data as probabilities of death within 1 year (1993), which had always been the case with older

versions of Prevent, but was now made more explicit since the groups from Denmark and Sweden were not aware of this definition.

9.3.3 Disease Specific Mortality

Specific mortality was defined using the ICD version 9. The risk factors that were to be put in the model were smoking, hypertension, and hypercholesterolaemia (see section 9.4.1). These risk factors impact largely on cardiovascular and respiratory disease, and we therefore decided to include the following diseases in the model:

- Lung cancer (ICD 9:162);
- COLD (ICD 9:491, 492, 496);
- CHD (ICD 9:410 to 414);
- CVA (ICD 9:430 to 438).

As indicated by its ICD code, the 'COLD' definition included chronic bronchitis, emphysema and COLD 'not otherwise specified', as most reported relative risks are calculated for these death causes. Asthma (ICD 9: 493) was excluded since it is a clinically distinct disease, especially at younger ages. Mortality from CHD was restricted to the 410 to 414 code, since the studies used to derive the relative risk values utilised this definition. Data were specified as 5 year age-group probabilities for base year 1993.

9.4 Risk Factors

9.4.1 Choice of Risk Factors

For public health policymakers, risk factors which contribute substantially to highly prevalent, serious diseases or accidents are the most interesting targets for intervention. For this phase it was decided to concentrate on those risk factors for which valid quantitative data could be obtained relatively easily in all four countries. These risk factors were smoking, hypertension and hypercholesterolaemia. Risk factors such as physical inactivity and alcohol consumption have been monitored less intensively, implying a wider gap between epidemiological data and model input, and so were not included in the model. In

addition, physical activity could not be included since prevalence data were only available for England & Wales, and did not exist for the other three countries. It was also decided to leave out obesity, as the evidence is still unclear as to what extent body mass index has an independent association with disease.

9.4.2 Risk Factor Classification

Smoking behaviour has been monitored extensively for many years in most countries. In contrast, there are fewer detailed empirical data on blood pressure or blood cholesterol levels in the general population. For instance, the Netherlands did not have blood pressure data at the population level. Not all countries had data on hypertension based on the same number of measurements, with the Danish and Swedish data based on one measurement, while those for England & Wales were based on three measurements. There were only hypertension treatment status data available for the England & Wales population, while historical blood pressure trend data were incomplete, in that they were not available, or had not been recorded, for long before 1993. Consequently hypertension had to be modelled in a rather simple way as a dichotomous variable. Cholesterol was modelled with two exposure categories. In addition, it was assumed that treated hypertensives had a relative risk associated with their actual blood pressure, irrespective of their treatment status. Historical trends in age-specific blood pressure were assumed to be zero due to the lack of valid empirical data, and to account for the age dependency of blood pressure and blood cholesterol level; age-specific trends were defined.

The amount of detail entered for the risk factor prevalence by exposure category for smoking, hypertension and hypercholesterolaemia was mostly dictated by whether the equivalent data on relative risks were available and on the detail to which risk factor prevalence was recorded in each country. For instance, to obtain the Netherlands hypertension data pooled analysis of various Dutch studies was used to estimate the probability of hypertension in the general adult Dutch population, and hence to estimate the prevalence of hypertension by age and sex. While for hypercholesterolaemia in the Dutch population only the lower cholesterol level cut-off to be used was recorded, and so the prevalence at the higher cholesterol level cut-off had to be estimated assuming a normal distribution. For Sweden the number of cigarettes smoked per day was only available for

1980 to 1989, and so the figures for 1990 to 1993 were estimated by multiplying the proportion of daily smokers in the population, which was available, with the relative distribution of smokers across the smoking exposure categories in 1989. Having access to the raw data of the Health Survey for England 1993 allowed me to analysis the risk factor exposure categories in any way that was required, and so I was able to adapt the risk factor exposure categories to conform with those of the other three countries.

We decided to define the risk factor exposure categories as follows:

- Cigarette smoking - 3 exposure categories: 1 to 12 cigarettes, 13 to 22 cigarettes, 23 or more cigarettes;
- Hypertension - 1 exposure categories: hypertension based on systolic blood pressure (160 mm Hg or more);
- Cholesterol - 2 exposure categories: hypercholesterolemia based on total cholesterol level (6.5 to 7.9 mmol/l, 8.0 mmol/l or more).

9.5 Relative Risks, Remnant Relative Risks, LAT and LAG Times

Prevalence and relative risk data from four different countries will never fit together perfectly. Every choice that was made while constructing the models implied a compromise between different considerations.

9.5.1 Smoking

The relative risks used in PREVENT 2.1 were the same for men and women, and as there are interesting differences in number of women smoking between the four countries; a search of the literature was made for gender-specific relative risk data associated with lung cancer, COLD, CHD and CVA, in addition to being age-specific. As a result of this it was decided to use the Framingham risk equation (Anderson 1990) to derive the relative risks of CHD and CVA mortality, with the relative risks for lung cancer and COLD taken from a systematic review (van de Mheen 1996). The remnant relative risks, and the LAT and

LAG times for lung cancer and COLD were determined from the American Cancer Society CPS-II prospective study data provided on request by Professor Michael Thun. Where these data deviated substantially from what has been reported in previously reviewed studies slight adaptations were made. Remnant relative risks for CHD and CVA were estimated from a function by Lightwood et al (Lightwood 1997) derived from a number of other studies.

9.5.2 Hypertension

Hypertension was to be modelled as a risk factor for CHD and CVA. After a search of the literature it was decided to derive the relative risks and remnant relative risks from the Framingham risk equation, since within the Framingham study hypertension was defined using data from several measurements, the relative risks could be estimated for different age groups and both sexes, and the blood pressure cut-off points were in line with WHO recommendations. The LAT and LAG times for both causes of death were derived from a review by Collins et al (Collins 1990).

9.5.3 Hypercholesterolaemia

Hypercholesterolaemia was to be modelled as a risk factor for CHD, and based on similar arguments to those for hypertension, it was decided to use the Framingham risk function to obtain the age-specific relative risks for CHD mortality. After reviewing the literature it was decided that the remnant relative risk of formerly having hypercholesterolaemia for CHD mortality would be one, if cholesterol was back to a normal level, and this would occur after 3 years of LAG time for both causes of death.

The relative risks, remnant risks and corresponding time lags that were finally decided upon were the same in all four models.

One of the advantages in using the Prevent model is the possibility of repeating calculations with different input data. For example, the lower and upper boundary of the relative risks as reported in the epidemiological literature can subsequently be entered into the model, enabling one to explore how sensitive the results are to these differences in

relative risks. However, if these upper and lower boundary for relative risks were included automatically in Prevent, the user could get a sense of the sensitivity of the model without having to reconstruct and re-run the model.

9.6 Country Specific Data for the England & Wales Version of PREVENT

My main task on this phase of the project was to update the England and Wales Prevent model. Since I had previously constructed a 1993 model this entailed my checking for the most up to date data sources and re-inputting data to conform with the chosen Biomed categories.

9.6.1 Population Data

All population data for 1993 was obtained from the Office of National Statistics (ONS), formerly the Office of Population Census & Surveys (OPCS). These included:

- Population structure in one year age bands by sex was estimated from the 1991 Census,
- General mortality in one year age bands by sex,
- Disease specific mortality in five year age bands by sex,
- Life expectancy by sex were based on life table data from the 1992-1994 period,
- Birth projections in period 1993-2043 were taken from population projections for the period 1991 to 2061, with estimates given in ten year periods. Using actual births in 1993 figures until 2043 were calculated by interpolation, and as these data were not gender-specific the proportion of boys and girls was calculated using the proportions for 1993 (0.512 for boys and 0.488 for girls).

9.6.2 Risk Factor Data

For the base year 1993 risk factor prevalence data on cigarette smoking, hypertension and hypercholesterolaemia were taken from the Health Survey for England 1993, and extrapolated to the England & Wales population. I had to extract the prevalence data in a form that conformed to the risk factor exposure categories and by the age groups that we had decided on in discussions as a group.

Within the Survey current cigarette smokers were only classified as such if they were also regular smokers, therefore there may be an over-estimation of never smokers, since they are actually those who have never regularly smoked.

For blood pressure, three readings were taken on one occasion, with the individual in a sitting position. The first reading was ignored, and all analysis was based on the average of the two subsequent readings. Valid blood pressure measurement were obtained from 13,565 adults.

Total serum cholesterol was measured in millimoles per litre (mmol/l) for the Survey, and for 11,840 adults whose blood samples had been taken and were usable.

For the trends in smoking prevalence since 1973 data were extracted from the General Household Surveys (GHS), again the data was obtained from the ESRC Data Archive. Smoking was not recorded in 1977, 1979, 1981, 1983, 1985, 1987 and 1989 by the GHS, and the tables in the Health Survey for England in 1991 and 1992 did not yield the required age groups, and so the figures were estimated by linear interpolation between years with data.

9.7 Modelling Smoking Interventions Across Four E.U. Countries

Having set up versions for Prevent for at least 4 E.U. countries, they can be used for simulating similar risk factor interventions in each country, and, from the results, cross European comparisons can be made. In this case, since data on cigarette smoking were

the most complete for all four countries it was decided that the cross-country comparison modelling should investigate the differential effect of various anti-tobacco measures. The running of the simulations were carried out by Dr Joke Mooy, with input from the rest of the Biomed group.

The group spent some time discussing the type of smoking interventions to be modelled, with members providing background information on each country's smoking policies and tobacco pricing. The types of interventions discussed centred around pricing and advertising policies, although there was some mention of health education and legislative interventions, such as the protection of non-smokers and sales restriction for youngsters, but these were thought to be difficult to quantify or too specific to each population. In addition, the limited time scale of this project and the fact that the modelling was being carried out by one person meant that Dr Mooy largely dictated what was to be simulated. The following policies were finally decided on as the ones to be simulated:

- an absolute price increase of tobacco products by one Euro;
- a proportional price increase of tobacco products by 10%;
- a hypothetical measure to set prices in all four countries to the same level as in Norway in 1995 (4.84 Euro's);
- a complete ban on tobacco advertising in all four countries.

The paper (Baan 1999) giving the full account of this modelling work is to be found in Appendix G.

Overall the effect of each of the interventions was small in terms of the percentage of premature deaths avoided, although the figures are more substantial when expressed as numbers of deaths postponed. However, this is just a reflection of the size of population, since a greater number of premature deaths are postponed in a larger population.

The modelling did highlight how the different policies would have different effects in each of the four countries. In terms of the percentage of premature deaths avoided by the year 2035 for the Netherlands the most effective policy would be the Norwegian pricing policy with about 4.5% and 2.5% decreases for men and women respectively. For England & Wales and Sweden the one Euro price increase and the Norwegian pricing policies would be equally effective, with 2% and 1.5% decreases for men and women in England & Wales, and a 0.5% decrease for men and women respectively in Sweden. While for Denmark the one Euro price increase policy would be the most effective resulting in approximately a 1% and 1.5% decrease in premature deaths avoided for men and women.

As with the physical activity modelling in Chapter 7, and the Birmingham model in Chapter 8, producing results of risk factor interventions just in terms of mortality is disappointing due to the small number of deaths avoided. This could make such work unappealing to policymakers since it seems as though drastic policy interventions will only make a small impact on health. In reality these interventions will have a greater impact due to their reducing morbidity, but this is not captured by Prevent and hence not translated in terms of the numbers of events avoided when reporting to policymakers.

Unfortunately I do not think anything new was learnt as a result of these interventions. The pricing scenario that would be most effective for each country was the one resulting in the largest proportional price increase, while the advertising ban scenario would be most effective in the country with the highest prevalence of smoking. These findings were simply illustrated by the modelling. The interventions need to be more sophisticated, with the pricing scenarios taking into account the relative price of cigarettes in each country, since the effect of any price increase will be dependent on the cost of living, and will be different for each country. The advertising ban scenario needs to take into account its effect on the uptake of smoking, since the modelling assumed that the effect of the advertising ban would only be to decrease the prevalence of smoking, and not decrease the prevalence of new smokers in the in-growing youngest cohorts. Both types of scenarios may also have had a different effect by sex and age groups, such as price increases having more effect on younger age groups due to their lower income. In addition, whether people

will reduce their consumption by the number of cigarettes smoked, or by switching to cigarettes with lower tar content, or whether people will quit due to the interventions needs to be considered.

9.8 Discussion

Seven years after Prevent's initial development it was important to update the model in terms of data concerning the core disease processes, such as the relative risks, remnant relative risk, LAT and LAG times, as well as updating the programme's operating system which in turn made the model more powerful and flexible with respect to the amount of detail the input data could be described in, see Chapter 10.

Creating the four E.U. versions of the model gave me an insight into the problems of finding appropriate and common population and risk factor data for these different countries, and demonstrated how, with such a comparison, one was forced to limit the detail of one's model due to limitations in other countries' data. For instance, no matter how much detail one's own population data described hypertension, with actual diastolic and systolic blood pressure values for each individual in a survey, which would allow one to define mild and severe hypertension; if another country's data could only describe normo-tensives and hypertensives, then one would have to limit one's own model to just normo-tensives and hypertensives to make valid comparisons.

Reviewing the objectives of the Biomed project:

1. to validate the models in the context of different E.U. countries:

The project provided a forum for clarifying how the input data for Prevent are defined, such as the definition of general mortality as a probability rather than a rate. The project also allowed the developers to explain some of the unclear methodological issues, such as understanding how the risk factor trends were calculated and applied. It also provided an opportunity to confirm that the variables used in Prevent, such as age groups, diseases, risk factors, disease/risk factor relationships, LAT and LAG time were consistent across the four country models.

As detailed in Chapter 5 it is impossible to validate Prevent in terms of using historical data to simulate current disease mortality, the traditional way of validating a model, since the model does not account for factors other than the included risk factors that would have affected mortality over time, such as other risk factors, or new medical interventions which increase survival. However, it was possible to validate the models in terms of “face-validity”, where we have tried to validate the data which are used in the model.

2. to compare the implementation, the utilisation and the results of Prevent in different E.U. countries:

The collaboration did give the members an insight into the each country’s data, in terms of which were available at a national, or regional level, and which needed to be taken from country specific studies, as well as the time periods these data cover. Unfortunately, as a working version of the updated Prevent was not available for use until the last few months of the project; this meant that the utilisation and the results of Prevent were not fully explored, aside from the modelling of smoking cessation policies. Since we did not talk to policymakers directly we did not get a sense of what were the key health policies relating to risk factor reductions in the four collaborating countries, which we should have tried to address in our modelling work.

3. the exchange of data, notably on risk factors, relative risks, new treatments and treatment outcomes, for inclusion in such models:

This was one of the most interesting aspects of the collaboration, giving us the opportunity to present and discuss the merits of using data from various studies. In addition, it meant that we were not all duplicating the same work in updating our versions of Prevent, which we had been doing previously, when working in isolation. Unfortunately, although these issues were discussed with all the members of the collaboration; it was often one of the developers who made the final decision on which data to use, as in the case of the decision to use relative risks derived from the Framingham equation rather than from the American Cancer Society CPS-II study, which the group had discussed.

The modelling of cross-country comparison of smoking interventions, the main deliverable of this project, was very disappointing. Simple interventions were simulated, and little additional knowledge was gained from the modelling experience, aside from illustrating the rather obvious results of the interventions. Unfortunately the interventions chosen to be modelled were decided upon without the input of policymakers; largely being dictated by the person responsible for carrying out the simulations. Ultimately they were not relevant to the current policy debate. This was clear from the lack of discussion by invited policymakers at the Biomed conference where the results were presented. To them the interventions would have seemed to have been devised in a policy vacuum, since they would not have understood why we had chosen these interventions. This again highlights how important it is for modeller not to be divorced from policymakers, and the need for policymakers to be involved in the process of deciding on what interventions are to be modelled.

Another aspect of modelling that this project did highlight was the importance of the availability of data for use within such models, particularly at a population level. Whether or not certain risk factor, or population characteristics, such as exposure categories and age group division, can be included depends on whether such attributes have been recorded in a population. Fortunately for the England & Wales model the raw data from the Health Survey for England were available to me, which included all the risk factors in Prevent, and gave me enormous flexibility in how I extracted my data for the model. Consequently we did not encounter many of the data obstacles that the members of the other countries came across, such as having only fixed risk factor cut-off measures, or age groupings.

9.10 Summary

This chapter describes my work on the BIOMED II project on Public Health Models in the period from 1996 until 1999. It outlines the Prevent related work of the project, in particular concentrating on my own work with the Prevent model, which involved producing a version of the model for England & Wales that was comparable with respect to population and risk factor data to models for the Netherlands, Denmark and Sweden. The chapter also summarises the cross-country comparison of different

smoking interventions modelled across the four countries, which was the aim of constructing these four comparable Prevent models.

Chapter 10 - The Development of PREVENT Version 2.8

10.1 Introduction

Prevent was originally produced in 1989, and since then the programme had not been developed to keep pace with the advances in computer technology, such as the increasing use of the Windows operating systems. The Biomed project gave Prevent's developer Dr Jan Barendregt the opportunity to update the Prevent model. The most notable change was that it was ported to Microsoft Windows NT from DOS, which meant that the programme could access more computer memory, and hence meant that many of the restrictions that were imposed under DOS on limiting the number of risk factors, diseases, diseases to be influenced by one risk factor, risk factors to influence one disease risk factor, age groups exposure categories and years of simulation were now lifted, see Chapter 1. Unfortunately the limited time-scale of the project, coupled to the fact that updating the model was not an objective of the project, and that work on updating the model was started late in the project, meant that Prevent Version 2.8 has not been completed or fully documented, and so is limited in its usability.

10.2 PREVENT Version 2.8

Prevent's port to Window's NT has resulted in the model being given a new interface, although very similar in structure to the DOS based version. The user now uses "drop-down" menus to first select the population data set using the File menu, then using the Options menu the user can select the diseases, the risks factors, the risk factor interventions, population options and the length of simulation runs for the modelling.

Under the Disease Options the user can now set disease specific mortality trends as well as risk factor trends, although the current version of Prevent does not have the risk factor trends implemented yet.

Using the risk factor intervention option the user can specify the change in risk factor prevalence to result from the interventions, now applied to 5 year age grouping, the year the intervention will start, and the year the target prevalences will be achieved.

The population option allows the user to set total mortality trends, and use a real population, or a stationary population. Although it is not explicit what the difference between these populations types are since no documentation has been produced on using the model and the Help facility has not been implemented yet. Unfortunately, neither have the risk factor options been implemented. The user can also access these options using the Specifications button.

Next, on the Options menu, the user selects the Output options which allow one to produce result as chart or tables, as rates, population numbers or use a standardised population, set the age of life expectancy results, synchronise dynamic charts and save output to a file, although this option has not been fully completed making it difficult to extract results.

The user is now set to run the simulation, which is achieved by pressing the Run button. After the simulation is completed the results window appears which allows the user to view the results by morality, disease specific mortality, population demographic, life tables and risk factors. Unfortunately only outputs that were available in the earlier versions of Prevent have been implemented. However, it is now possible to view the charts dynamically since a slider allows the user to animate the yearly changes over time.

All the input data is now entered into one Microsoft Excel spreadsheet file for each data set instead of using the Prevdata programme, which used to create a number of data files. This Excel file is then used by the Prevent programme, which means the user must have Excel installed on their computer to use the model. Since the data input is now straight into a spreadsheet it means that there are no constraints to what can be input, so relative risks less than 1.0 can be input. However, this does mean that the user must be particularly careful when entering data as there are no processes that check for valid data, as was the case with Prevdata.

10.3 PREVENT Plus

Prevent, known as Prevent Plus, was also updated to include morbidity, disability and cost for the Netherlands; requiring the following data:

- Disease specific incidence rates by 5 year age groups and sex;
- Disease specific prevalence rates by 5 year age groups and sex;
- Disease specific disability weights by 5 year age groups and sex;
- Disease specific costs per prevalent case by 5 year age groups and sex.

Some of these data did not exist at a population level for the Netherlands, so they had to be derived from limited data in combination with informed "guesstimates" by Dr Luc Bonneux and Dr Barendgret. They had originally made these guesstimates for their work on the NIMPH model. Much of these required data did not exist for the whole of the England & Wales population either. However, I was able to obtain the following data:

- Lung and breast cancer incidence and survival data from the Thames Cancer Registry for South East England;
- Lung and breast cancer registration (incidence) data from ONS for England & Wales (ONS 1997);
- MI and stroke hospital admission and re-admission data for England from the Hospital Episode Statistics (DoH 1995);
- MI and coronary death incidence and case fatality for the Scottish MONICA population of Glasgow (Tunstall-Pedoe 1996);
- Stroke incidence and survival rates from the Oxford Community Stroke Project (Bamford 1988) data set.

Unfortunately, the developers have not documented the process of deriving the

appropriate input based on these limited data, and the limited time-scale for the project meant that the developers only had time to input the data for Denmark and Sweden, which were in the correct form and needed no further manipulation. I was therefore unable to implement these features.

It was frustrating to be so reliant on the developers, in that they were the only people who could construct a model and who knew about the assumptions underlining their derived data, which may not apply to another country's population. Unless the developers have a similar understanding of the health of that other population; it is debatable whether the same assumptions can be applied to the new population, and this certainly limits the model's usability by others for other populations. I think that a model based on data that is unlikely to be available at a population level, as in the case of incidence, prevalence and disability is of limited value. This is particularly the case when the developers of the model cannot easily convey their assumptions for deriving the data.

This raises the "chicken and the egg" argument about which should come first, the model or the data to drive the model. As described in Chapter 1, a model allows one to conceptualise a process into its component parts, and so allows one to highlight the data needed to simulate that process. This was evident in my modelling work for Birmingham Health Authority, which highlighted the lack of risk factor and mortality data by ethnic group, and the need for these data if the Authority wanted to simulate interventions directed at these groups. At a population level, such data could be extracted from the Health Survey for England. In general terms, some of the data required by the Prevent model are available from regional and national health surveys. At the other extreme is a model like Prevent Plus, which requires morbidity data that are not readily available in a form that is representative of the whole population. This demonstrates how models can highlight the lack for these data and the need for their collection. Due to the lack of these data even in the country for which the model was initially developed, assumptions need to be applied to what data are available, but these assumptions are undocumented, and possibly rely, to some extent, on the developers' subjective judgements. These aspects make the derivation of these data for other

situations difficult, and so limit the models transferability and usability as a policy tool by others.

10.4 Discussion

The updating of the Prevent model was an opportunity to address some of the limitations of the model, such as not being able to shift risk factor exposure distributions, not being able to move individuals to a number of risk factor exposure categories rather than just the non-exposed category, and not having univariate risk factor prevalences which would allow one to identify high risk sections of the population. Unfortunately these limitations were not addressed because different priorities were set, and because some of these problems were difficult to solve.

The morbidity and cost version of Prevent seems very difficult to translate to other populations due to the lack of appropriate data and the assumptions used to derive the appropriate data. I spent a considerable amount of time identifying, obtaining and extracting morbidity data for this part of the project; only to be unable to input the data myself due to lack of documentation. The developers did not have the time or the incentive to input the data, and so an England & Wales version of Prevent Plus was not constructed.

The work has illustrated how models should be developed on the basing of using available data, even though they can highlight areas where data are lacking. In the case of Prevent Plus this scarcity of data and the lack of clear methods for deriving these required data has made the model untransferable, and so unusable by others in different situations.

The main problem with the new version of Prevent is that it is not complete and is undocumented to the extent that it is unusable by anyone who has not had considerable experience of using the previous version of Prevent and was not party to its recent development. The model is less user-friendly due to the lack of documentation and the fact that it has not been completed. Three years is too short a time period for even updating an existing model, let alone developing a new model, when the developers are only able to carry out the work on a part-time basis.

The most frustrating aspect of the project was the failure to address some of, what I feel are, the fundamental limitations of the Prevent model in terms of being able to use the model to simulate policy relevant interventions. Model developers may not be aware of the importance of certain issues because they have been working in isolation from policymakers.

10.5 Summary

The chapter describes the development of the Prevent model which took place during the course of the Biomed project, with regard to its move to a Windows NT platform, and the problems associated with its update. In addition, the development of Prevent Plus, the morbidity and cost version of Prevent, is described, and the reasons why we were unable to produce a version for England & Wales are discussed.

Chapter 11 – Discussion of the PREVENT Model

11.1 Introduction

In the last six chapters I have described my work with the Prevent model, using it a tool with policymakers. The model was originally designed by Professor Gunning-Schepers and implemented by Dr Barendregt. The original aim in producing the model was that it would be used as an aid for policymakers who, having been show how to use the model, would use it themselves for simulating risk factor interventions. Policymakers would then be able to test alternative strategies to achieve their policy goals, or to calculate the magnitude of effect of various interventions.

As a public health model for policymaking Prevent has some positive and negative aspects which affect how it can be used and what it can be used for. Within this chapter I discuss these aspects with regard to how important I feel they are in affecting the model's usability.

11.2 Positive Aspects of PREVENT

On first impressions Prevent is an attractive package, with the Prevdata programme guiding the users through the data input process, while the simulations model's user-friendly menu-driven interface makes the running of interventions a simple process to follow. These are important aspects in making the model useable for an individual with a non-technical background, such as policymakers may be. The data input process also gives the user the opportunity to study and organise their population's demographic and risk factor data, which in turns will give them a better understanding of these data that underpin the model. This is an important understanding to gain since it is required in order to fully interpret the model's output.

One of the key strengths of Prevent is its ability to link the demographic changes within a population over time to risk factor prevalences, since the effect of any risk factor interventions will be heavily influenced by the risk factor's distribution by age group and sex in a population. This leads on to another of the model's strengths, which is its

ability to allow the user to simulate interventions while targeting by age group, sex and risk factor exposure level. Such targeting allows a comparison of the effect the same interventions in different sections of the population to investigate which will produce the most health gain. This is illustrated with the interventions modelled in the Birmingham population in Chapter 8.

I have stated earlier, in Chapter 6, that Prevent's methodology limits one, even using the modifications I made when modelling the physical activity targets, to simulate interventions that move individuals from exposure categories to the non-exposed category, or just one exposure category. However, in spite of this limitation the model is effective in modelling certain interventions, such as smoking interventions where the aim is to get individuals to stop smoking rather than to cut down their consumption. I have shown with the work on physical activity and the work in Birmingham that these are some of the types of interventions that policymakers would like to know the effects of, and so it means that the model is able to address certain relevant policy issues.

The model has also been shown to be a useful tool for hypothesis testing when current knowledge is incomplete, as in the case of my simulating the attenuation of risk with inactivity at older age groups. Prevent allows the user to investigate how changing various assumptions concerning the risk factor and disease relationship, which may be under debate in the research arena, will affect the outcomes of an intervention.

Another positive aspect of the model is the way in which it can demonstrate what may be achieved if target risk factor prevalences, or screening strategies are met. This was the case with the modelling for Birmingham Regional Health Authority where the local GP group found the results from Prevent could be an incentive to their work, since they only witness the effect on individual patients, while the model showed the overall effect on the whole population or constituency.

11.3 Limitations of PREVENT

A major limitation of the model is that it is not possible to move individuals to a number of lower risk factor categories, nor is it possible to shift risk factor distributions.

Although with, say, a smoking intervention, policymakers would want smokers to stop smoking; in reality smokers may cut down their consumption by smoking fewer cigarettes, or cigarettes with a lower nicotine content. It is not possible to model such scenarios with Prevent. Health promotion policies at a population level, such as those aimed at lowering the population's cholesterol level will cause a shift in the distribution of cholesterol level across the whole population to a lower level, rather than all the individuals achieving the cholesterol level with the least risk, and Prevent cannot model this type of scenario either.

Another aspect of the model which limits its use for health promotion and public health interventions is Prevent's use of univariate risk factor distributions, rather than a multivariate distribution, which means that it is not possible to target high risk groups who have a clustering of risk factors, since only the independent risk factor distributions are input and used by Prevent.

Limitations to the number of demographic and risk factor categories that are allowed with Prevent means that it is not possible to construct populations in such a way that would enable policymakers to address interventions aimed at particular sub-groups of the population, as was the case with the Birmingham modelling when it was not possible to sub-divide the population by ethnic group. The latest version of Prevent overcomes this problem, so when it is completed, the only barrier to such sub-dividing of the population will be whether data are available.

Although it is possible to run Prevent a number of times using upper and lower relative risks of mortality estimates from the literature; it would be more helpful to be able to input these bounds for the relative risk into the model at the initial data input stage. Then the model could calculate the confidence interval for the output in one run. This would make Prevent more useful as a policy tool, since having to constantly update relative risks, then re-run the model using the bounds of the relative risks, and finally amalgamating the results of these runs is a laborious task.

Lack of morbidity outcomes is another major limitation of the model, particularly since for many risk factor interventions the effects are very small in terms of the number of

deaths avoided, while changes in disease incidence and prevalence may be substantial. Without morbidity in the model it is not possible to present policymakers with the whole effect of an intervention, and they may feel that an intervention is not worth pursuing since they will only see that it prevents a relatively small number of deaths. A methodology for calculating morbidity measures that can easily be transferable to other populations needs to be devised, since the new version of Prevent uses a method for calculating morbidity outcomes which relies on informed "guesstimates" which only the developers fully understand, and which are specific to the Dutch population. I feel that this is not an ideal situation if others are to adapt, use and understand the model. If assumptions are used in fitting data into the model, then the user must be able to explain these assumptions to translate the model's output to policymakers.

One of the problems of trying to address some of these limitations is the lack of documentation for the model. It is easy to see how this has arisen since Prevent was developed by others, who initially only looked at the model in terms of being part of a PhD thesis, and who expected that it would be used by others in only a limited fashion. Due to the lack of documentation it is impossible for others to adapt Prevent in terms of reprogramming the model.

There was never a commitment on the part of the developers to working on the model past its initial development. This meant that further development was not a priority and as their research agenda moved on; changes to Prevent had a low priority. Fortunately the Biomed II project provided an opportunity to develop the model, although in the end only the aspects that the developers thought important to update, or that could be achieved in the limited time of the project were addressed. Possibly the most disappointing aspect is that new version of Prevent is unfinished, and not usable because of its lack of documentation, and the need for undocumented information on how to use the model and interpret its output.

11.4 Conclusions

Over time both Professor Gunning-Schepers and Dr Barendregt have come to the conclusion that the model is too complex to be used by policymakers on their own.

They feel that instead Prevent should be used by modellers who understand its workings and its input data. From my experience with the model, I would agree with this method for using the model in policymaking, since it is only by using the model extensively that I have gained a full understanding of Prevent, and this has taken several years to achieve. Although I feel that policymakers should specify the interventions to be simulated rather than the modeller.

Unfortunately Prevent still has a number of limitations as a model for simulating risk factor interventions for policymaking, and these I believe are rooted in the fact that Prevent was developed, to a certain extent, in isolation from the policy arena. All interventions have to be couched in terms of changing an individual's risk factor exposure from an exposed category to the non-exposed category. Since the policy agenda changes over time, and it is usually dictated by political priorities rather than research priorities, policymakers need to be part of the development of models such as Prevent. Such models must be able to simulate the interventions that policymakers feels are important, rather than those that researcher feel are important. The output of modelling will be ignored if it is not relevant to the policy agenda.

Overall, Prevent is a usable tool for policymaking, although the type of interventions that it can simulate are limited. Users need to be aware of these limitations when deciding whether or not Prevent is the right model to use for modelling their interventions.

Users of Prevent must also be aware that although it seems a relatively simple model to use they need to fully understand the model's input data and its methodology to interpret the model's output.

Section 3: POHEM

Chapter 12 - POPULATION HEALTH MODEL (POHEM)

12.1 Introduction

The Population Health Model (POHEM) (Wolfson 1991 and 1992²) uses the micro-simulation technique to model the dynamics of multiple risk factors and major diseases, including CHD, lung cancer and breast cancer, under various demographic and health-related processes for a heterogeneous population.

The micro-simulation technique depends upon a monte-carlo process. Each individual in a cohort is generated separately using a random process, and over the simulation period these individuals can be subjected to certain events; the probabilities of these events being drawn randomly from distributions. These models have the capacity to absorb all the required risk factors and interdependencies. Consequently they require more processing power than their cell-based counterparts. Statistics Canada run POHEM on a dual Pentium II 266Mhz with 132Mb DRAM where a simulation of 100,000 individuals would take about fifteen minutes.

The monte-carlo process generates random life tables, where, within each year, an individual is randomly simulated to either die, become ill, or stay well. The probabilities of changing states are randomly drawn from age specific uniform distributions. This process is repeated a considerable number of times, following each individual from birth to death, and so producing a large synthetic cohort.

Since POHEM avoids having to stratify the population by age, sex and risk factor levels, as with cell-based models, it does not start off computationally too memory hungry. The model does not have to run calculations for the whole population at the same time during the simulation period, but only has to keep track of one individual and their risk factor levels at a time. However, micro-simulations do take longer for a simulation run, and require more data storage space, because they have to generate and record the lifetime of each individual of the cohort separately.

As well as the monte-carlo process, POHEM uses a number of dynamic algorithms to simulate socio-economic status, risks factors, diseases, health care utilisation and summary health status, as mentioned in Chapter 3.

Within the Disease process is the CHD model, which uses Weinstein's Coronary Heart Disease Policy Model (Weinstein 1987) transformed to be consistent with the POHEM architecture, and uses Canadian risk factor distributions and treatment protocols. The CHD module allows the user to simulate the effects of intervention, both preventive, by risk factor modification, and therapeutic, by changing case fatality rates, on mortality, morbidity and costs over time. The CHD module is made up of three consecutive parts, see Figure 12.1:

- A demographic portion, which generates disease free individuals, who are then aged. It uses a logistic risk function based on the Framingham equation to calculate the annual incidence rates of CHD events for each individual.
- A bridging portion, which simulates the initial 30 days after the incidence of the first CHD event, with individuals having been passed on from the demographic model. First it determines the type of CHD event by age range and sex, then applies probabilities of death during the first 30 days following the event by age, sex and type of event. A survivor then moves into the next sub-model.
- A disease history portion, which classifies the individual with a previous CHD event into twelve CHD states. In each simulation year the patient is subjected to eight CHD event probabilities, which they may or may not experience, and each event and state have associated case fatality rate for CHD and non-CHD death, depending on disease history, age and sex. These case fatality rates are applied to the individual to calculate those who survive to the next year of simulation and those who die.

Overall the methodology of POHEM gives it great flexibility, with its ability to include external factors such as social status and environmental exposure, as well as the traditional risk factors. In addition, the model can produce more detailed information on

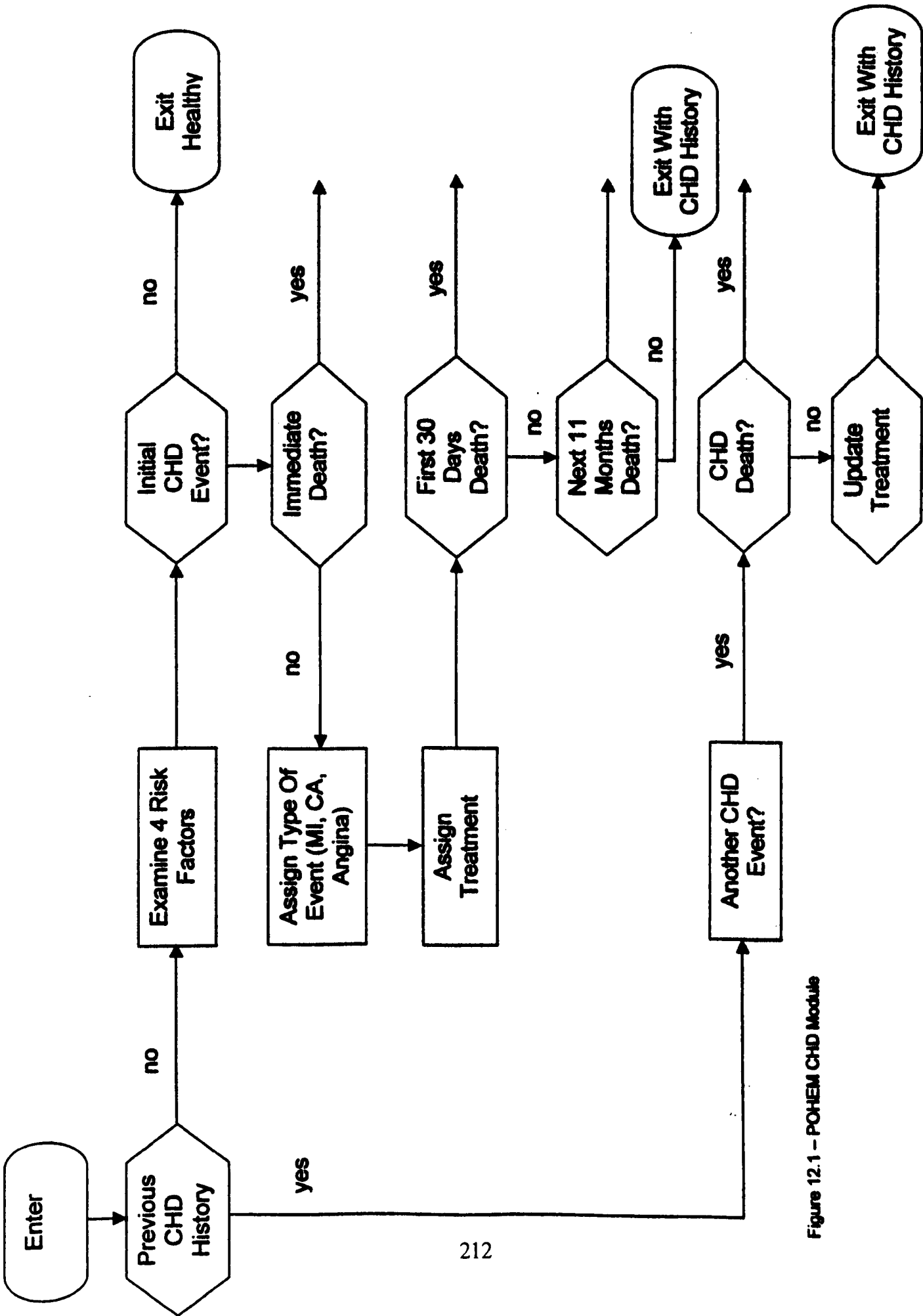

Figure 12.1 - POHEM CHD Module

morbidity, in terms of functional and health status, and costs, in terms of health care utilisation.

12.2 Development of POHEM

POHEM evolved from what was originally an actuarial model called DEMOGEN, the objectives of which were demographic and social policy analysis. DEMOGEN modelled the following processes explicitly:

- educational attainment,
- union formation,
- fertility
- labour force participation / earnings,
- union dissolution,
- remarriage,
- child separation,
- mortality.

As a result of this history POHEM also incorporates these mechanisms, and has the ability to generate families by first creating an individual who will age, be educated and go to work, then marry if the appropriate partner is generated and who is also aged. Then, depending on fertility parameters, this couple may have children, which are also generated and aged. In addition, the couple may get divorced, or the initial individual's partner may die, and the initial individual may remarry, while the children may be separated from this individual due to the divorce or death.

POHEM was originally written in APL with interventions being modelled by editing the source code of the programme, then compiling the source code to produce an executable programme, which was then executed to run the simulation. In 1994, with a view to making POHEM more accessible to other users and to allow more widespread development of the programme, Statistics Canada converted it into the Modgen programming language, which is a superset of the C++ programming language, running in the Windows NT environment. Modgen is modular in form and uses object orientated

programming techniques, where each programme is a collection of individual objects that interact with each other, and each object has its own programme code and data.

The Modgen language was developed by the Health Analysis And Modelling Group at Statistics Canada specifically for the development of dynamic longitudinal micro-simulation models, and has become the language used for all their micro-simulation modelling work, not just POHEM. The language is designed to allow application developers to simulate the lifetimes of linked individuals and related family members, known as actors. In addition, Modgen provides a number of methods for reporting the output of simulations, such as cross-tabulated results in ASCII or Microsoft Excel spreadsheet formats, or as a relational database of actor information in Microsoft Access format.

As with the APL version, the initial Modgen version of POHEM did not have a user interface, as used by Prevent. The user edited the source code to initialise the model and to produce results. The ease with which the user can modify the code results from Modgen being an object orientated programming language with a modular structure, and this means that the user does not have to modify large sections of code, but just the appropriate modules to modify the programme for different simulation runs. In addition, unlike the Prevent source code, POHEM's is well documented, with comments throughout the code to explain the program's workings.

In order to set up a simulation the user edits MPP files, the Modgen source code files, which are processed by the Modgen pre-compiler, and this produces CPP files, which are the C++ source code files, and H files, which are the C++ library files, that are then compiled with the MODLIB library file by the Visual C++ compiler to produce the POHEM.EXE file. This file, when run, reads the input data files (parameter DAT files), runs the micro-simulation and finally produces reports of the output, see Figure 12.2.

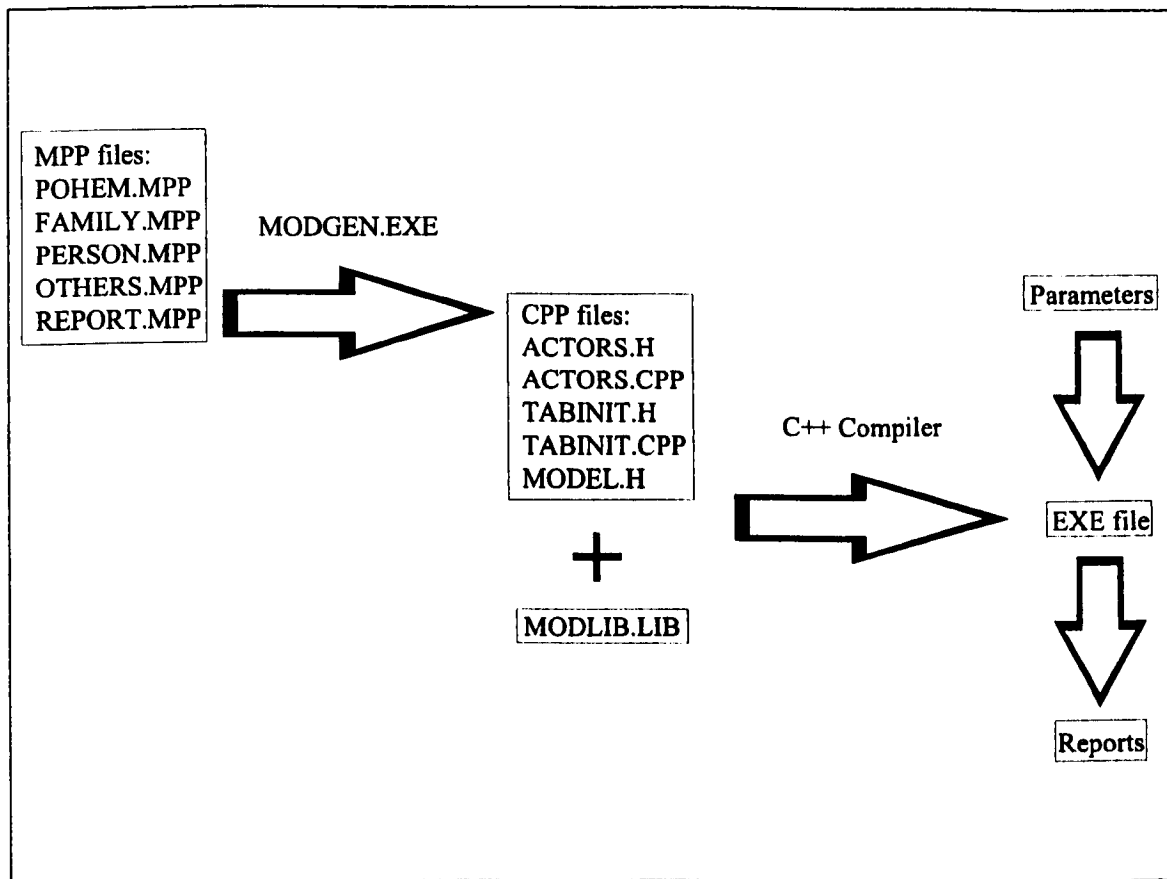

Figure 12.2 – POHEM diagrammatic: pre-compilation, compilation and running

The MPP files are where one enters the definitions of special programming objects in the simulation code. There are five such source files, as described in the Statistics Canada documentation (Statistics Canada 1998):

- POHEM.MPP is the main model file, which contains the definitions of general purpose classifications, ranges and parameters, such as the type of union, sex classifications and the range for the duration of a life. In addition, it contains the more complex parts of the actor definitions, such as initialising households and creating or removing children from the household.
- FAMILY.MPP contains the definitions of Household-related classifications, ranges and parameters, such as the number of individuals, adults and children in the household. It also contains the definition of the Household actor, the code of CaseSimulation function and the code of the Household class member function, which are used for creating households, and for applying demographic and health events to all household members.

- **PERSON.MPP** contains the definitions of Person-related classifications, ranges and parameters, such as risk factor exposure levels and value ranges. As well as containing the definition of the Person actor and the code for the Person class member function, such as creating partners, unions and children.
- **OTHERS.MPP** contains the definitions of Child-related and Ancillary-related classifications, ranges and parameters, such as the sex and age of children and partners. It also contains the definitions of the Child and the Ancillary actors, and the code of the Child and the Ancillary class member functions, such as applying demographic and health events to partners and children.
- **REPORTS.MPP** contains the definitions of required reports, which will produce cross-tabulation tables by age and sex of key variables, such as disease events, marriage and risk factor levels, as well as the average age of key events.

12.3 Using POHEM

The initial version POHEM.EXE ran as a DOS programme, and did not allow any user interaction with the programme. It just read the parameter files, ran the simulation and produced the output reports. In the next incarnation of POHEM the user used a scenario file (SCE extension file) to set up the programme, which is a DOS command line for the POHEM.EXE programme. The command line allowed the user to set various aspects of the simulation run, such as:

- the number of cases to be simulated,
- number of individual cases to be tracked during the simulation to an Access database,
- the time to the end of the simulation (simulation period),
- the random number generator seed value,
- the output options, such as to Access database, Excel spreadsheet or text files.

In addition, the scenario file could be loaded into a visual viewer which was used to set the model's inputs data files, as well as viewing and editing the list tables to be output and some of the modelling settings.

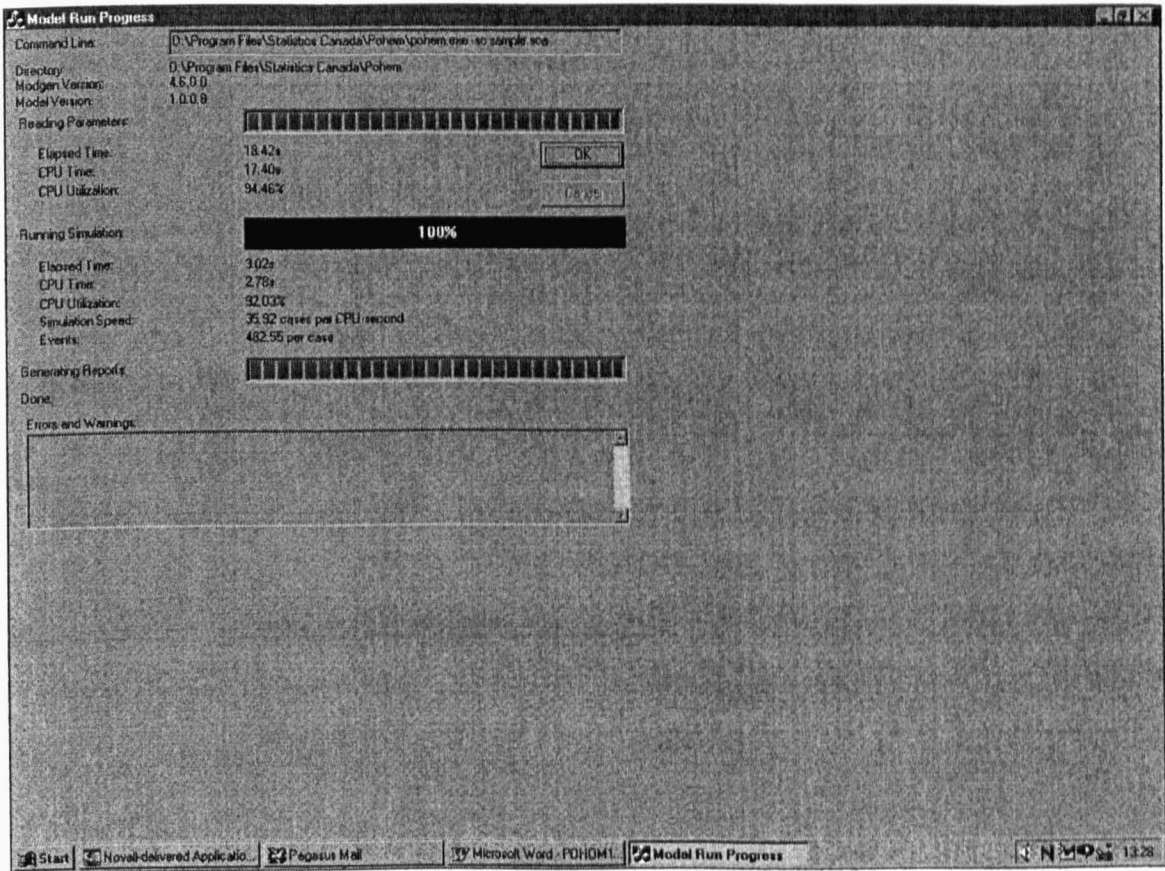

Figure 12.3 – POHEM.EXE window

The POHEM.EXE ran as a Windows NT programme that still did not allow the user any interaction with the programme, but it did produce an on screen window that enabled the user to monitor the progress of the programme in terms of reading the parameter files, running the simulation and producing reports, see Figure 12.3.

The current version of POHEM.EXE has incorporated the file viewing and the monitoring programmes into a single programme. Again the user must specify a scenario file which will load the appropriate data files to be used by the programme, or the user can create a new scenario file by choosing the data files to be used for the simulation. The loaded data files are displayed in the viewing window, see Figure 12.4.

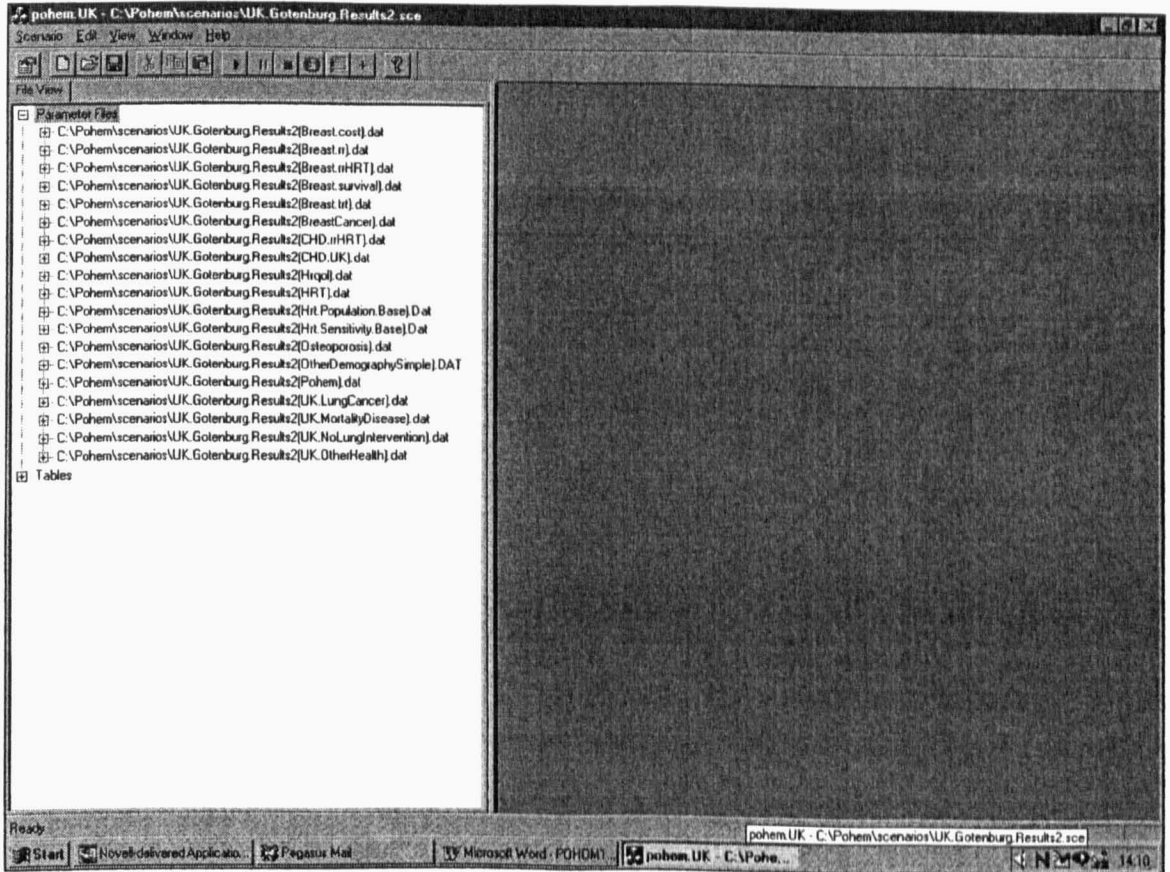

Figure 12.4 – POHEM.EXE with scenario file loaded

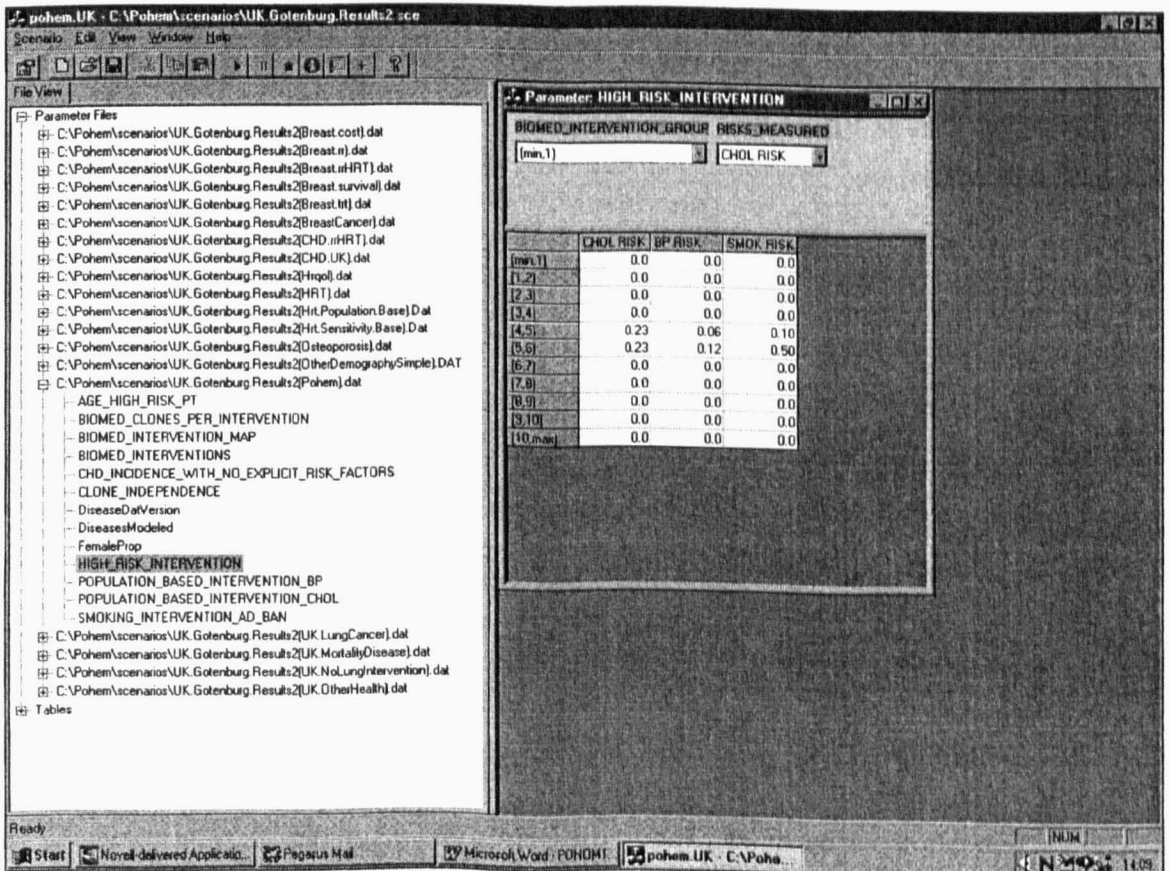

Figure 12.5 – POHEM.EXE: an example of modifiable variables in a data file

Although the types of interventions to be simulated are specified in the MODGEN code; the latest version of POHEM.EXE does allow the user to change certain variables within the data files. By clicking with the mouse on a data file path the user can display the variables that can be modified by the user, which will depend on the initial MODGEN coding, and clicking on one of this will display the variable. An example is shown in Figure 12.5.

In addition to viewing the data files and modifying certain variables the programme allows the user to specify a number of settings for the simulation run. These settings are categorised as General, Inputs, Output options, Output parameters and Output tables.

Each category can be accessed by clicking on the appropriate tab in the Execution Control window.

I. General - within this section the user can adjust such settings as:

- The number of cases to be simulated,
- The number of threads by which a number of different individual can be generated and simulated concurrently, depending on the number of processors the computer has,
- The number of sub-samples,
- The starting seed for the random number generator,
- Scaling the numbers in the cohort to that of an actual population .

II. Input - this section allows the user to add, remove and replace the data files that are associated with the scenario file, and that are used by POHEM.

III. Output Options - the output options that are available to the user are:

- Standard error values,
- Coefficient of variation values (%),
- MS Access tracking and number of cases tracked,
- MS Excel tables,
- Documentation database,
- Text tables,
- Text tracking.

IV. Output Parameters - this section allows the user to select pre-coded variables to be output. The variables are chosen from a list and include such variables as the mean and standard deviation of risk factor exposure levels, disease incidences and event probabilities.

V. Output Tables - this section allows the user to select pre-coded tables to be output, which are also chosen from a list and includes variable such as the number of deaths, cause of death, age of disease onset and disease incidence.

12.4 Running POHEM

The model produces standard errors on the outcomes. It does this by randomly assigning each case to one of sixteen sub-samples and calculating standard errors on the sub-samples for the selected outcomes. Since all interventions are done in a single run, it is possible to generate the differences between the interventions and reference case as an outcome with the standard errors. Consequently, it can be determined whether the reported differences were statistically significant using a 95% confidence interval.

12.5 Overview of POHEM

Although POHEM has not been developed as a user friendly executable programme; the ability of the user to programme the model and the modular form of its coding gives the model great flexibility, and so means it has the capacity to include numerous factors and

processes, since they can be programmed in. More importantly the model's ability to produce information on morbidity, as well as mortality, makes it an invaluable tool for assessing the effectiveness of health interventions where the effect on mortality may be small, but the gains in terms of morbidity will be significant.

In the following chapters I will present how I have used POHEM to model various risk factor interventions in the England & Wales populations, and how POHEM compares with Prevent, in terms of their different methodology and how that influences the types of interventions they can model.

12.6 Summary

This chapter describes the POHEM model, in terms of the adaptation of Weinstein's Coronary Heart Disease Policy Model for use in its CHD model, and its development from an existing actuarial model written in APL to the current Windows NT C++ version. In addition, details of how to build and run the model are discussed.

Chapter 13 - Developing The England & Wales POHEM

13.1 Introduction

POHEM was originally designed for use with data from the Canadian population, and was built to address Canadian health policy issues. And so the initial part of the work with POHEM involved discussions with Mr Jean-Marie Berthelot and Mr Bill Flanagan at Statistics Canada about the type of model I wanted to produce for England & Wales. The Canadian version of POHEM has a complex multiple disease/risk factor environment with a myriad array of factors which can influence an individual's health in a simulation, as previously described in Chapter 12, and which would be difficult to replicate for another population within a limited timeframe. This work was carried out in conjunction with a European Union Biomed project on public health models, one of the aims of which was to compare POHEM with Prevent. It was decided that we should try to match the risk factors and the diseases required for duplicating interventions between the two models, and in particular the smoking interventions which had been modelled as part of the Biomed project, detailed in Chapter 9. Consequently Mr Berthelot, Mr Flanagan and I decided on a primary prevention model, which would simulate the effects on morbidity and mortality as a result of risk factor interventions. We decided not to include secondary care interventions or costs for this initial work.

The Framingham CHD risk equation is at the core of the CHD module of POHEM, and this dictated that we would require data on the risk factors included in the equation; which are obesity, cholesterol, blood pressure and cigarette smoking. Chapter 14 details the justification for using the Framingham equation with the England & Wales population. The Biomed project's interest in simulating smoking interventions meant we would also need to model in POHEM the other diseases associated with smoking in Prevent, which are CVA, COLD and lung cancer.

This chapter discusses the building of the England & Wales version of POHEM in terms of its data requirements, running the model, and the output to be produced by the model. These aspects were to some extent dictated by the interventions that POHEM was to simulate, as described in Chapter 15.

13.2 Data Requirements

The minimum data requirements, as specified by Statistic Canada, to build the POHEM model outlined in section 13.1 were:

- I. Life tables by sex,
- II. Mortality rates by 5 year age groups and sex for CHD, CVA, COLD, lung cancer and all other causes,
- III. Multivariate discrete risk factor distribution by age and sex for smoking, blood pressure, cholesterol and obesity, using the following categories:
 - smoking: 1-12, 13-22, 23+ cigarettes ex-smoker and never smoked,
 - diastolic blood pressure: <95, 95-104, >=105 mm Hg,
 - cholesterol: <250.9, 250.9-308.7, >=308.8 mg/dl,
 - obesity: BMI <25, 25-30, 30>=.
- IV. Univariate mean and standard deviation for each risk factor distribution by age and sex,
- V. Lung cancer incidence and survival by stage, sex and age group.

13.2.1 Data Sources

For the England & Wales version of POHEM the only new data that had to be collected were the lung cancer data, while producing the multivariate risk factor distribution entailed re-analysing the data set from which the Prevent independent distributions had been derived. Mortality data were re-analysed to conform with the POHEM age groupings.

For the cancer data no one source was able to supply incidence and survival by stage and disease. Incidence data were available for England & Wales from the Office of

National Statistics, but not by stage of diagnosis. These data were supplied by the Thames Cancer Registry, along with survival data, for South East England, however the survival data could not be supplied by age group.

As detailed in section 12.2, POHEM has the ability to simulated mechanism which affect individuals such as educational attainment, union formation, fertility, labour force participation, earnings, union dissolution, remarriage, and child separation. However, the version of POHEM I have been using has these mechanisms “switched off”, since the simulations I have undertaken were not dependent on families needing to be generated, or on whether the individual was employed. The model was simplified with only separate individuals created, aged and followed until death.

13.2.2 Data Input

The multivariate risk factor distribution by age group and sex for cholesterol, blood pressure and smoking were used to smooth transitions of risk states between age groups. This was achieved by treating the transitions as a transport flow problem from one age group to the next, constrained by the risk factor distribution and other restrictions inherent to the data, and were produced using a programme developed by Statistics Canada. The result was a set of transitional probabilities applied to the individuals over the course of their synthetic lifetime. The initial risk states were determined directly from the initial age group of the risk factor distribution.

The univariate risk factor mean and standard deviation by age and sex were used to assign a specific risk value in POHEM, assuming the risk factors were normally distributed within risk states.

Incidence data for heart disease were derived by inverting the Weinstein model with the country specific mortality data provided, by sex and age group. Incidence data were provided for lung cancer by sex and age group. Incidence data were not available for CVA nor COLD, so the mortality numbers were used as incidence data with progression from incidence to mortality being immediate. This assumption does not reflect reality, and hence will lead to an underestimation of the effect of CVA and

COLD on morbidity, since there will be no period of morbidity. In addition, the assumption will cause an overestimation of mortality for these diseases, since an individual will die immediately from the initial development of CVA or COLD, while it may take some time for them to die from CHD or lung cancer in the model.

For each disease, “background” incidence rates, the incidence amongst those not exposed to the risk factors, were derived by removing the portion of the incidence attributable to the explicitly modelled risk factors obtained from the Framingham equation. The model applied the relative risks, as used by Prevent for CVA, COLD and lung cancer and derived from the Framingham equation for CHD, to the background incidence rates to determine an individual’s probability of getting a disease at a given age.

13.3 Output

POHEM allows the user numerous output options, which would result in an overwhelming amount of data if all were recorded. Accordingly, some decisions about which measures to choose had to be made. Prevent only produces results in terms of mortality, so for the POHEM interventions I chose some mortality output to make a comparison, as well as some morbidity measures to highlight that aspect of POHEM’s methodology. The output measures I finally decided on to assess the effect of the interventions were:

13.3.1 Mortality Output:

- I. Changes in life expectancy,
- II. Age and disease specific mortality rates,
- III. Changes in disease free life expectancy,
- IV. Number of people reaching 70 and 85.

13.3.2 Morbidity Output:

- I. Number of cases of disease,
- II. Average age of disease onset,
- III. Average number of years lived with disease.

These outputs can be expressed as yearly totals, or can be aggregated as totals for the whole cohort over its entire life-span. These are the outputs used in the risk factor intervention simulations described in Chapter 15.

13.4 Summary

POHEM was originally produced for a Canadian population, and so had to be adapted for use with the England & Wales population. This chapter discuss the building of the England & Wales version of POHEM in terms of its data requirements, running the model, and the output to be produced by the model. The model produced was used for simulating the risk factor interventions described in Chapter 15.

Chapter 14 - Using The Framingham Equation With The Population of England & Wales

14.1 Introduction

14.1.1 The Framingham Study

Between the 1930s and the 1950s cardiovascular disease (CVD) became the leading cause of death in the USA, with coronary artery disease (CAD) being the most common cause for this high mortality. At that time, since there were no known treatments capable of prolonging the life of those with CAD, it was felt that only a preventive approach could substantially reduce the burden of this disease (Kannel 1988).

At the time the contribution epidemiology had made to the control of infections and nutritional diseases led some public health workers to consider applying the approach to the investigation of CVD (Kannel 1988). As a result the Public Health Service through the National Heart Institute established a prospective investigation of factors possibly related to the development of coronary heart disease and hypertension (Dawber 1966). The study was established in 1949 in Framingham, Massachusetts, with an initial followed up period of 20 years, but this was changed and the study is still continuing. The Framingham Study involved selecting a representative sample of the town's adults to be followed up for the development of initial cardiovascular events in relation to biennially measured attributes and living habits suspected of contributing to the occurrence of CAD (Kannel 1988). Initially 5209 people aged 30 to 62 years were examined (Feinleib 1975).

In the original cohort there were 1644 spouse pairs, the children of whom formed the basis of a second study called the Framingham Offspring Study. Over a period of 4 years, from 1971, these offspring, aged 12 to 60 years, were invited for physical examination at the Framingham Heart Study Facilities (Kannel 1979). The aims of the Framingham Offspring Study were to determine whether there had been any secular changes in risk factors between the two generations of the cohorts, and to examine the

presence of familial and genetic effects in determining the level of these risk factors (Feinleib 1975). By 1975 5135 offspring were enrolled in the study (Kannel 1979).

14.1.2 The Framingham Equation

The Framingham equation is a logistic regression model which provides predicted probabilities for several CVD endpoints. The equation is based on the measurement of several known risk factors taken from 5,579 members of the Framingham Heart Study and Framingham Offspring Study cohorts, with an age range of 30 to 74 years, and who were initially free of cardiovascular disease and cancer (Anderson 1990).

The equation includes the following CVD risk factors:

- Age;
- Sex;
- Systolic blood pressure;
- Smoking;
- Total cholesterol;
- High density lipoprotein (HDL) cholesterol;
- ECG-left ventricular hypertrophy.

The equation has been used to calculate the risk of the following outcomes:

- Myocardial infarction (MI) (MI, including silent and unrecognised MI);
- Death from coronary heart disease (CHD) (sudden or non-sudden);
- CHD (consisting of MI and CHD death plus angina pectoris and coronary insufficiency);
- Stroke (including transient ischaemia);
- CVD (including all the above plus congestive heart failure and peripheral vascular disease);
- Death from CVD.

14.2 Generalisability

The Framingham equation has been used as the basis of several other public health models aside from POHEM, including the Coronary Heart Disease Policy Model (Weinstein 1987) and the Netherlands Integrated Model of Public Health (NIMPH) (Bonneux 1994), as a means of generating CVD events for simulated populations. The cited reasons for its widespread use are its excellent methodology, the long term follow-up, and that it allows the estimation of risk in women, unlike many other risk equations (Haq 1999).

However, the issue of the generalisability from a single community population to a larger or a different setting is not clear, and the participants in the Framingham studies are not necessarily representative of the total US population, with various geographic, socio-economic and ethnic groups being underrepresented (Grundy 1998). In addition, the baseline measurements for the Framingham studies were in the period from 1968 to 1975 (Anderson 1991). In the last 30 years CHD mortality rates have declined substantially, and the extent to which this decline can be attributed to the major risk factors is uncertain (Marmot 1992). Other issues of concern that can make the use of such logistic risk functions problematic when applied to new populations are variations in the definition of events, the duration of follow up and the definition of the risk variables used (Chambless 1990).

Many of the above models assume that the observations in a specific cohort are generalisable to their population of interest, even when the population is that of another country, as in the case of NIMPH and POHEM. Nevertheless, how generalisable the Framingham equation is to other populations has been an issue of much debate.

14.3 Problem of Validation

The main difficulty in being able to justify the use of the Framingham equation is validating the event rates generated by the equation for a new population by comparing them with the actual event rates for that population. This is problematic due to the lack of available data on actual event rates. Although CVD is recognised as contributing to

the major burden of disease in developed countries (WHO 1982); there are very few registers of CVD events (Marmot 1992), particularly in terms of morbidity measures such as incidence, prevalence, recurrence and survival, especially not at national levels. As a result the only population comparison that can be made are in terms of mortality and of rank ordering of risk, although it is possible to apply the equation to other study cohorts for which CHD event data are available.

14.4 Review of the Literature

14.4.1 Leaverton *et al* (Leaverton 1987)

The Framingham equation was applied to the first cohort of the National Health and Nutrition Examination Survey (NHANES I) Epidemiological Follow-up Study (NHEFS), which was a national cohort study based on a comprehensive medical examination of a probability sample of the United States adults. The Framingham equation was compared to a similar regression equation for the NHEFS with respect to predicting death from CHD.

	Males		Females	
	Framingham	NHEFS	Framingham	NHEFS
Age	0.0781	0.0619	0.1034	0.1059
Systolic blood pressure	0.0168	0.0133	0.0237	0.0215
Serum cholesterol	0.0040	0.0049	0.0065	0.0099
Cigarette smoking	0.4700	0.7815	0.6979	0.8985

Table 14.1 – Multiple logistic function coefficients by sex and study

It was concluded that the Framingham equation was generalisable to the white United States population, since the coefficients of the equation were very similar to that of the NHEFS cohort, see Table 14.1. In addition, both equations produced similar distributions when they were applied to the Framingham population, and individuals in the population were then ranked in terms of quintiles of multivariate risk.

14.4.2 Chambless *et al* (Chambless 1990)

Fifteen logistics risk functions, including the Framingham equation, were compared in terms of their odds ratios for given changes in risk factor levels for cholesterol, systolic blood pressure and smoking. In addition, the ratio of the odds ratios for CHD events of cholesterol, systolic blood pressure and smoking were compared as a means of showing how much the relative size of the three coefficients differed among populations, e.g. OR_{SBP}/OR_{CHOL} , OR_{SMK}/OR_{CHOL} , OR_{SMK}/OR_{SBP} .

The review concluded that there was sufficient variation between risk equation in the value of the coefficients, the odds ratios for risk factors and the ratios of odds ratios to suggest that extrapolating these risk equations to new populations was not justified.

14.4.3 Assman *et al* (Assman 1990)

Data from the Prospective Cardiovascular Munster (PROCAM) study was used to derive a multiple logistic function including total cholesterol, HDL cholesterol, age, systolic blood pressure, smoking, diabetes, angina and family history of MI to predict CHD events. Data from the Helsinki Heart Study (HHS) population were applied to this model and a version of the Framingham equation which did not include HDL cholesterol, and were then compared in terms of their estimates of the number of CHD events in a gemfibrozil, which is a lipid lowering therapy, treatment group and a placebo treatment group.

In comparison to the PROCAM equation, which was thought to accurately estimate coronary events in the Helsinki Heart Study population, it was found that the Framingham equation overestimated the number of events in the treatment group and underestimated them in the placebo group, see Table 14.2. However, it was noted that this difference probably reflected the fact that the PROCAM equation included HDL cholesterol and that the version of the Framingham equation used did not.

	Number of CHD events		
	Estimated		Observed
	PROCAM	Framingham	HHS
Gemfibrozil treatment group	61	67	58
Placebo treatment group	82	76	84

Table 14.2 – Estimated number of CHD events in the Helsinki Heart Study using equations from the Framingham and PROCAM studies, compared to the observed number of events

14.4.4 Laurier et al (Laurier 1994)

A multi-factorial CHD prediction model based on the Paris Prospective Study, for males aged 43 to 53 years, was compared to the Framingham equation by applying data from the Prévention Cardio-Vasculaire en Médecine Travail (PCV-METRA) study in terms of predicted CHD risk estimates. The PCV-METRA is a prospective study of cardiovascular risk factors in workers from several firms in the Ile-de-France region of Paris, and was made up of 4131 males and 1635 females aged 30 to 65 years.

It was found that the Framingham equation's estimated risks were higher than that of the PCV-METRA model, showing that the equation tends to overestimate CHD morbidity when applied to populations with low CHD mortality rates, such as the French. However, it was found that modification of the sole constant term increased agreement from 29% to 80%, with the modification reflecting the adjustment in the basal CHD risk.

14.4.5 Grover et al (Grover 1995)

Using the CHD Prevention Model, which is based on the Framingham equation, each individual in the Lipid Research Clinic (LRC) Prevalence and Follow-up Studies cohort was assigned a 12 year CHD mortality risk, and ranked according to their risk, and this was compared to the screening guidelines proposed by the National Cholesterol Education Program (NCEP I and NCEP II) and the Canadian Consensus Conference on Cholesterol (CCCC).

It was concluded that the equation could be incorporated into CHD prediction charts for use by clinicians since it was able to discriminate high-risk and low-risk subgroups among whom the incidence of future events will vary substantially (Grover 1999).

14.4.6 Liao *et al* (Liao 1998)

The Framingham equation was compared to two regression models based on systolic blood pressure, serum total cholesterol and smoking derived from the NHANES I and NHANES II studies in terms of their multivariate regression coefficients for CHD death. In addition, the Framingham equation was used to predict the absolute survival rate of CHD in the two NHANES studies.

For the prediction of CHD mortality rate the Framingham equation was thought to provide a reasonable rank ordering of risk for individuals in the white US population, but it was felt that its prediction of absolute risk was less accurate. The authors noted that the equations should be used with caution when generalising to a different population, and that it may be inappropriate for use with populations of countries or ethnic groups that have much lower or higher CHD incidence and mortality rates than the Framingham sample population.

14.4.7 Wilson *et al* (Wilson 1998)

A coronary prediction algorithm was developed using data from the Framingham and Framingham Offspring cohorts, using categorical blood pressure measures from the Joint National Committee and cholesterol measures from the National Cholesterol Education Program, and then comparing the results with that of the Framingham equation with its continuous categories. In addition, the generalisability of using data derived from the Framingham Study was discussed.

It was felt that the categorical model could predict CHD risk in a middle-aged white population sample. Caution was recommended in generalising to other populations, and that the model was most appropriate for individuals who resembled the sample population.

14.4.8 Grundy *et al* (Grundy 1998)

This paper discussed the use of the Framingham risk score in developing national guidelines for risk factor management, as well as its appropriate use.

It was concluded that charts based on the Framingham equation provided a realistic picture of a given individual's true absolute and relative risks. Even though one must be aware of potential differences among various populations when applying the equation; quantitative differences in risk predictions are likely to be small amongst most populations. In addition, the authors noted that users should remember that the Framingham equation does not take into account all risk factors for CHD.

14.4.9 Hingorani *et al* (Hingorani 1999)

The cardiovascular risk predicted by a computer program based on the Framingham equation was compared with actual risk derived from randomised control trials of cholesterol reduction. The trials in the comparison were the West of Scotland Coronary Prevention Study (WOSCOPS), the Scandinavian Simvastatin Survival Study (4S) and the Cholesterol And Recurrent Event trial (CARE).

The Framingham equation successfully predicted the event rate in the placebo arm of the WOSCOPS study, although not for the 4S and CARE studies. This was thought to be due to the fact that both the 4S and CARE include individuals with pre-existing cardiovascular disease, whereas the WOSCOPS study only included disease-free individuals, as did the Framingham studies. It was concluded that the equation was applicable to a UK population without clinically evident atherosclerotic disease, and that it was clearly appropriate for predicting the effect of primary prevention, but is less valid in the setting of secondary prevention, see Tables 14.3 and 14.4.

End point	Predicted risk reduction (%)				Observed risk reduction (%)	
	Absolute risk		Relative risk		Absolute risk	Relative risk (95% CI)
	Non-smoker	Smoker	Non-smoker	Smoker		
CHD	2.3	3.3	31	28	2.5	29 (15 - 40)
MI	1.4	2.7	40	31	2.0	27 (12 - 40)
CHD death	0.5	0.9	46	40	0.2	33 (1 - 55)
Stroke	0.0	0.0	0	0	0.16	11 (-33 - 40)

Table 14.3 – Effects of cholesterol lowering in primary prevention of cardiovascular disease in 55 year old men with hypercholesterolaemia: predictions by the Framingham computer program compared with observed risk reductions in WOSCOPS

End point	Predicted reduction in relative risk (%)				Observed reduction (95% CI) in relative risk (%)
	Males		Females		
	Non-smoker	Smoker	Non-smoker	Smoker	
<i>4S</i>					
CHD	50	39	58	47	33 non-fatal 48 fatal
CHD death	55	49	62	58	42 (27 - 54)
<i>CARE</i>					
MI	41	32	49	39	23 (4 - 39) non-fatal 37 (-5 - 39) fatal
Stroke	46	40	56	49	20 (-5 - 39)

Table 14.4 - Effects of cholesterol lowering in secondary prevention of cardiovascular disease: predictions by the Framingham computer program compared with observed risk reductions in the 4S and CARE trials

14.4.10 Durrington *et al* (Durrington 1999)

For a series of 570 Manchester patients without pre-existing clinical evidence of atherosclerosis referred to a lipid clinic the algorithms, charts and tables used by the US National Cholesterol Education Program (NCEP), the joint guidelines of the European Society of Cardiology, the European Atherosclerosis Society, and the European Society of Hypertension, and the report of the UK Standing Medical Advisory Committee were compared with the Framingham risk equation in terms of CHD risk.

It was found that the Framingham equation broadly agreed with the European charts when applied to the same patients.

14.4.11 Haq et al (Haq 1999)

The individual CHD event risk estimates for 206 consecutive Sheffield men, aged 35 to 75 years without pre-existing vascular disease, as predicted by the Framingham equation were compared with the PROCAM, Dundee and British Regional Heart Study (BRHS) risk functions.

There was found to be close agreement between the Framingham, PROCAM and Dundee risk functions in terms of average CHD risk, and moderate agreement for estimates within individuals. The authors felt that there was already ample evidence to suggest that the Framingham equation predicts relative risk of CHD with reasonable accuracy in diverse populations, while their study suggested that the Framingham equation was acceptably accurate for predicting absolute risk in British hypertensive men, and this could probably be extended to all British men.

14.4.12 Statistics Canada (personal communications)

Dr Michael Wolfson and Mr Jean-Marie Berthelot, who have used the Framingham equation to generate events within the CHD module of POHEM, feel that the equation can be generalised to the Canadian population. They have used the technique described by Assmann et al of modifying the constant term in the equation in order to obtain agreement between the observed and predicted mortality in the Canadian population. However, they do stress that since there are no national CHD event incidence registers to validate the adapted Framingham equation output; one must be aware that the predictions could be wrong. There is no way of accurately checking.

14.5 Discussion of the Framingham Equation

Table 14.5 summaries the methods for investigating the generalisability of the Framingham equation used in the papers reviewed, either by comparing the events generated by applying the data from study populations to the equation or, by comparing the equation to other risk scores.

Paper	Comparison	
	Study Events	Risk Scores
Leaverton et al	✓	✓
Chambless et al		✓
Assman et al	✓	✓
Laurier et al	✓	✓
Grover et al	✓	
Liao et al	✓	✓
Wilson et al		✓
Grundy et al	✓	
Hingorani et al	✓	
Durrington et al	✓	✓
Haq et al	✓	✓

Table 14.5 – Summary of the methods used to investigate the generalisability of the Framingham equation

Overall the papers concluded that the Framingham equations were applicable to populations that were similar to the Framingham cohorts, particular predominately white populations with high cardiovascular mortality.

Only one paper, Chambless et al, expressed a view that it was not justifiable to apply risk equations to new populations. However, the paper did not specifically investigate the generalisability of the Framingham equation, but was a comparison of the coefficients of different risk equations. The authors reached their conclusion based on the fact that these coefficients were different, and did not apply the equations to different populations. The only other paper which expressed some doubt was that of Liao et al, which concluded that relative risk derived from the Framingham equation could be applied to a US white population, but felt that it was not justifiable to apply the absolute risks generated by the equation. This was in keeping with the views expressed by Laurier et al and those at Statistics Canada who suggested modifying the constant term in the Framingham equation to overcome this problem.

One concern with reviewing these papers was that the majority of them were only able to investigate the generalisability of the Framingham equation to male populations, due to the lack of data on women. Consequently the issue of whether the equation is applicable to women as well has not been explored as thoroughly as it has for men.

Ideally one would like to validate the equation by comparing its predicted risks with those of the population of interest, but since no data are available at a national level this cannot be done. Some of the papers reviewed have tried to validate the equation by applying it to other cohorts, but this can only be seen as a partial solution since one can also question how similar these cohorts are to other populations, particularly the British.

Nevertheless, of the 11 papers and one personal communication reviewed the majority expressed the opinion that the Framingham equation could justifiably be generalised for use with other populations with some modification, including the British, or England & Wales population.

14.6 Summary

This chapter begins by describing the Framingham Heart Study and the Framingham Offspring Studies. The chapter then outline how data from these studies were used to derive the Framingham Equation, and describes the equation in terms of the CVD risk factors it incorporates and the CVD event probabilities it generates.

The chapter also discusses how the Framingham Equation has been used as the basis for generating CVD events by several health policy models, as well as discussing its generalisability to other populations and the difficulty in validating the equation's output when applied to other populations.

The chapter includes a literature review of applications of the Framingham Equation to other populations, where the output from the equation has been compared to the results from trial and other risk equations. After discussing the review I conclude that the equation can justifiably be used with the England & Wales populations within POHEM.

Chapter 15 – A Comparison of the POHEM and PREVENT Models

15.1 Introduction

In this chapter I outline the POHEM related work of phase three of the Biomed II project, as originally outlined in Chapter 9. The objectives of this phase of the project were to compare the performance and output of a micro-simulation model (POHEM) to a cell-based macro-simulation (PREVENT) model. The comparison was to concentrate on the following aspects:

- Data needs – comparing the volume and complexity of the data required,
- Generalising and adapting the models for different populations,
- Flexibility in addressing additional questions,
- Interpretation – can the results from simulations be easily understood for policy making.

15.2 Differences Between Prevent and POHEM

In addition to the different approaches to simulation, there are a number of other differences between the two models that must be considered in a comparison.

15.2.1 Cohort Versus Population Model

The most important of these differences is that POHEM generates a synthetic cohort whereas Prevent uses a whole population. With Prevent there is a dynamic population made up of all ages, which during a simulation period has individuals dying and being born. Although POHEM follows individuals from birth to death through all ages; all the individuals simulated are “born” in the same year and so one can only follow this cohort over time. It is not possible to simulate the effect of an intervention targeted at the whole, or part of the population other than one birth cohort with POHEM. This makes it

difficult to compare like interventions with like outcomes for Prevent and POHEM, since one can only compare the effects of an intervention on the same cohort in the two models.

15.2.2 Shifting Risk Factor Exposure

Prevent only allows simulations to move people from risk factor exposure categories to an ex-exposed category, which has a remnant relative risk, as a result of an intervention. For instance, with Prevent changing heavy or light smokers to ex-smokers is possible, but changing heavy smokers to light smokers is not. This means that it is impossible to shift the risk factor distribution, as would be the effect of a population intervention, such as would be the result of a national campaign to reduce individuals' cholesterol, but this is possible with POHEM, although only in terms of the effect on a cohort.

This is an important issue to address since preventive strategies may have only small effects on the risk experienced by an average individual, but may have large benefits at a community or population level. This is the so-called prevention paradox, where if a large number of people each reduce their risk slightly, the entire population may show a large reduction in adverse events.

15.2.3 Univariate Versus Multivariate Risk Factor Distributions

Prevent uses independent risk factor distributions, where within the model the prevalence of risk factors are input and used separately. Although there may be prevalence data for smoking, hypertension and hypercholesterolaemia individually; there are no data for the prevalence of these risk factors in combination. That is, no allowance can be made for the clustering of risk factors in individuals. POHEM, by contrast, does use this type of multivariate distribution, and so allows the user to simulate high risk intervention strategies that target those individuals who have a clustering of risk factors. This helps to address important policy questions regarding whether health resources should be targeted to those at most risk and who might benefit the most from an intervention, rather than using a population approach in which health resources are not targeted, but used to change population distributions of risk.

15.2.4 Relative Risks Versus the Framingham Equation

For each risk factor/disease combination Prevent uses the independent relative risk of disease specific mortality, whereas POHEM was designed to use a logistic regression equation, the Framingham equation, to calculate the probability of CHD morbidity and mortality events, and incidence and survival rates to calculate the probability of cancer morbidity and mortality.

In the version of POHEM used in this work country-specific mortality figures were used as a proxy of incidence for CVA and COLD, with progression to death following immediately.

Since there would obviously be differences between the output of the two models due to their using different methods to calculate risk, POHEM also was adapted for use with the Prevent relative risks to calculate mortality, so allowing me to make a closer comparison.

15.2.5 Past and Future Trends Versus Present Trends

For certain risk factors, such as smoking, on cessation of exposure an individual's risk will not immediately reduce to the lowest possible risk level (the remnant relative risk), but will take a number of years to reach this level. In addition, this reduction in risk may not start instantaneously on cessation of exposure. It may take a number of years before the elevated risk due to the individual's previous risk factor exposure begins to decline. Within Prevent these time dimensions are known as LAG and LAT respectively.

This concept of LAG and LAT times implies that there will be a slow reduction in risk over time, and means that not only will the effect of interventions be seen in the future, but also that the prevalence of risk factors in the past will determine the incidence of disease in the present. As a result past risk factor trends need to be input for Prevent. In the case of smoking and COLD this means that risk factor trends as long as 20 years ago are required. Such trends may be difficult to calculate due to the limited availability and reliability of data. In addition, future trends need to be input to simulate how risk factor

levels will change during the course of the simulation period due to factors other than the interventions being modelled. These trends can only be guessed.

The original version of POHEM does not take these LAG and LAT times into account. It generates individuals and follows them for their whole life-span, and so generates a life-time's risk factor history. POHEM uses the multivariate risk factor transition matrices, that is the probability of moving from one category of risk factor exposures between age groups, to calculate how risk factor levels change over time. These matrices are calculated using the multi-variate risk factor distribution from existing cross-sectional data. This means that POHEM assumes that changes in risk factor level over time will match the current changes between age groups.

These differences between the two models were taken into consideration when I chose the interventions to be simulated, and the interventions chosen include both population and high risk strategies.

15.3 Interventions

Since Prevent only simulates the effect of risk factor interventions on mortality and POHEM is a cohort model, the only interventions that could be used to compare the two models would be risk factor interventions aimed at one birth cohort.

The interventions to be modelled were chosen after discussion and a search of the literature for achievable risk factor changes. The first intervention is a direct comparison with one of the Prevent smoking interventions modelled for the Biomed project as described in Chapter 9, while interventions II and III highlight POHEM's ability to simulate high risk and population strategies.

I. Ban on cigarette advertising

- Advertising ban scenario: A total ban on cigarette advertising in England & Wales would result in a 6 % reduction in the prevalence of cigarette smoking (Baan 1999).

The effect of such a scenario aimed at those aged 20 to 24 was simulated, and modelled in terms of the lifetime impact for the cohort.

II. High risk approach

The high risk approach targets individuals who are at high risk of CHD due to a combination of risk factors, and attempts to reduce these risk factors at the same time. Individuals with a clustering of high levels of smoking, blood pressure and cholesterol at age 50 were chosen, using the Prevent cut-offs for the high risk factor levels:

- 10% reduction amongst those individuals who smoke so that they become ex-smokers at age 50,
- 23% reduction in cholesterol levels amongst those individuals with a level greater than 260 mg/dl at age 50,
- 6% reduction in diastolic blood pressure levels amongst those individuals with a level greater than 95 mm Hg at age 50.

The percentage reductions in risk factor levels were taken from the literature, and were attributed to the effects of nicotine replacement therapy (Foulds 1996), statin therapy (4S Group 1994 and Shepard 1995), and antihypertensive drug therapy (Collins 1990).

III. Population based interventions, which reduce the risk factor distributions of all age groups the cohort will pass through.

Shifting the risk factor distribution:

- 2% reduction in cholesterol levels.
- 2 mm Hg reduction in diastolic blood pressure.
- 6% reduction in the number of smokers.

The reductions in risk factor levels were taken from the literature, and were attributed to the effects of dietary changes on cholesterol (Brunner 1997), lifestyle changes on blood pressure (BMJ 2000), and a cigarette advertising ban on smoking (Baan 1999).

It was assumed that the changes in risk factor prevalence due to the interventions would persist for the rest of the cohort's lifetime, which probably will lead to an over-estimation of the true effect of the interventions, since in reality some individuals may revert to an increased risk over time. The alternative would have been to have made some assumptions about what percentage of the cohort that would revert to an increased risk state over time, but these assumptions may also be unrealistic.

15.4 Output

POHEM allows the user numerous output options, which would result in an overwhelming amount of data if all were recorded. Accordingly, some decisions about which measures to choose had to be made. Prevent only produces results in terms of mortality, so for the POHEM interventions I chose some mortality output to make a comparison, as well as some morbidity measures to highlight that aspect of POHEM's methodology. The output measures I finally decided on to assess the effect of the interventions were:

15.4.1 Mortality Output

- I. Changes in life expectancy,
- II. Age and disease specific mortality rates,
- III. Changes in disease free life expectancy,
- IV. Number of people reaching 70 and 85.

15.4.2 Morbidity Output

- I. Number of cases of disease,
- II. Average age of disease onset,
- III. Average number of years lived with disease.

15.5 Initial Adaptation of POHEM

In order to make the two models as comparable as possible, POHEM was adapted to use the relative risk approach used in PREVENT. It was necessary to reassign the risk states in POHEM to match those in PREVENT. The risk state determined the relative risk to be used, but in POHEM it was applied to the incidence data whereas in PREVENT it was applied directly to mortality. Disease progression for CHD used the Canadian model, however, the country-specific mortality rates were reproduced. Survival time from incidence of lung cancer from country-specific data was used to reproduce the overall mortality.

The LAT and LAG effects modelled in PREVENT for the impact of smoking on disease were adapted for use in POHEM. In particular, they were applied to the incidence rather than mortality. In PREVENT, the LAT and LAG are applied when an individual moves from a risk factor exposure category to the non-exposed category. In POHEM, it is possible to move more smoothly between risk categories and increase or decrease the level of risk. Consequently, the LAT and LAG effect was applied whenever there was a decrease in risk state and the relative risk of the lower risk state was used where remnant risks were not applicable. An increase in risk state immediately negated any LAT and LAG currently in effect.

In addition, the interventions described previously were implemented into POHEM's architecture.

15.6 Results from the Initial Adaptation

The smoking intervention was run with both Prevent and POHEM, then the results from each simulation were combined in an Excel spreadsheet, and the figures for each disease modelled were produced showing the number of deaths postponed during the simulation period, see Figures 15.1, 15.2, 15.3 and 15.4.

Having produced the figures, I noticed that for the reductions in lung cancer and COLD deaths, as shown in Figure 15.1 and 15.2, the output from Prevent peaked much later than that produced by POHEM. The results from Prevent showed that the greatest benefits from the smoking intervention would be seen when the cohort was 90 to 94 years old for lung cancer and 100 to 105 years old for COLD. This seemed far too late considering the current burden of mortality for these disease in the population of England & Wales, with the number of deaths peaking for lung cancer at 70 to 74 years and for COLD at 80 to 84 years (OPCS 1995²). One would expect the intervention to have a greater effect 20 years earlier, which is reflected in the results from POHEM. In addition, the Prevent output showed a much greater number of CVA and CHD deaths postponed for females than for males, which was also at odds with current CVA and CHD mortality patterns.

Although POHEM was producing the more plausible results, it was using a new methodology that had been transferred to its architecture. I checked with POHEM's developers that they had implemented the current Prevent LAT and LAG times, as well as relative risks and remnant relative risks, in the model. Mr Flanagan checked POHEM and confirmed that he was using the same values for these variables. Therefore I concluded that they may be a problem with the updated version of Prevent, and so contacted Dr Barendregt to ask if there could be a problem with Prevent. He ran the same intervention and confirmed that there was something wrong with the results produced by the new version of Prevent when intervening on a single cohort rather than the whole population. Unfortunately he has not yet been able to correct this problem, so some other method for comparing these models had to be considered.

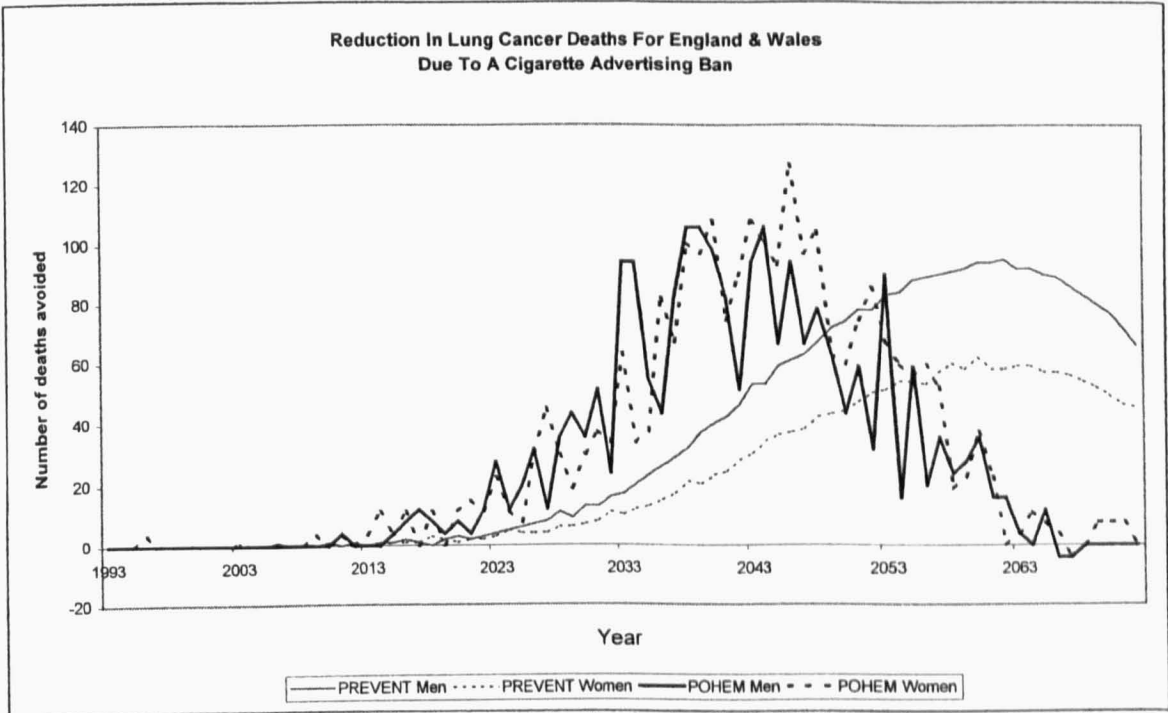

Figure 15.1 - Reduction in lung cancer deaths for England & Wales due to a cigarette advertising ban: Prevent Model versus POHEM

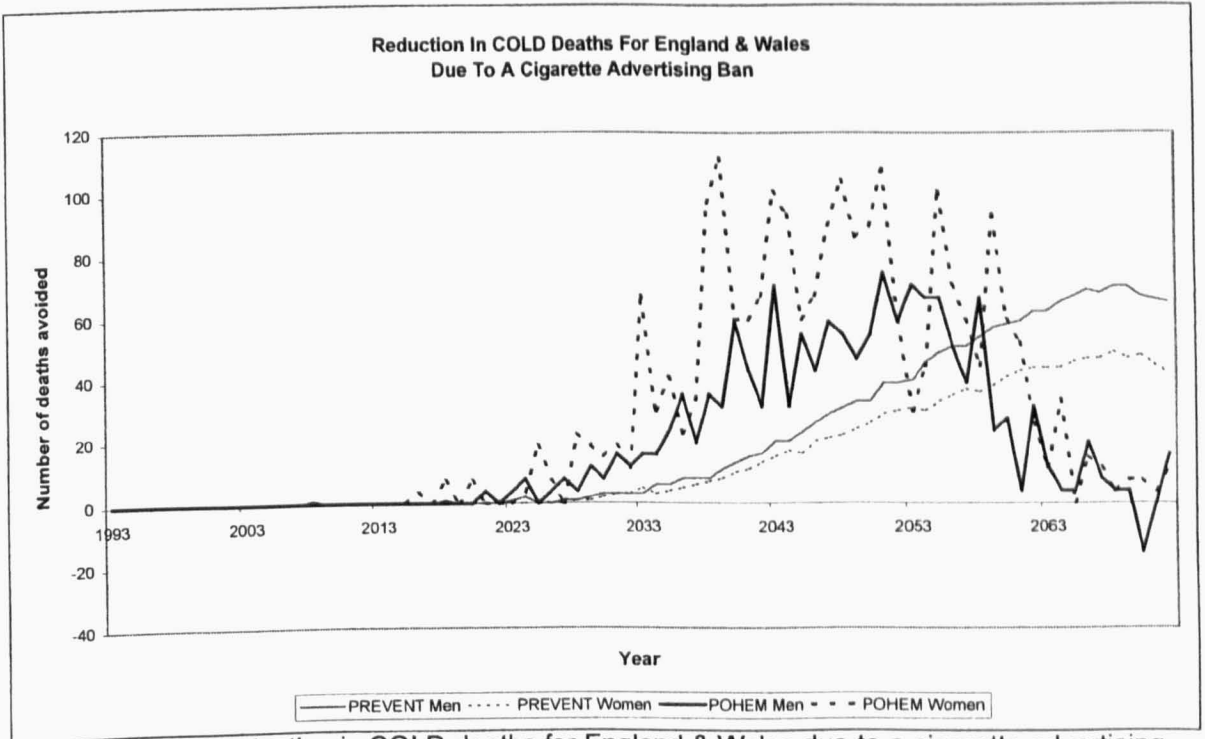

Figure 15.2 - Reduction in COLD deaths for England & Wales due to a cigarette advertising ban: Prevent Model versus POHEM

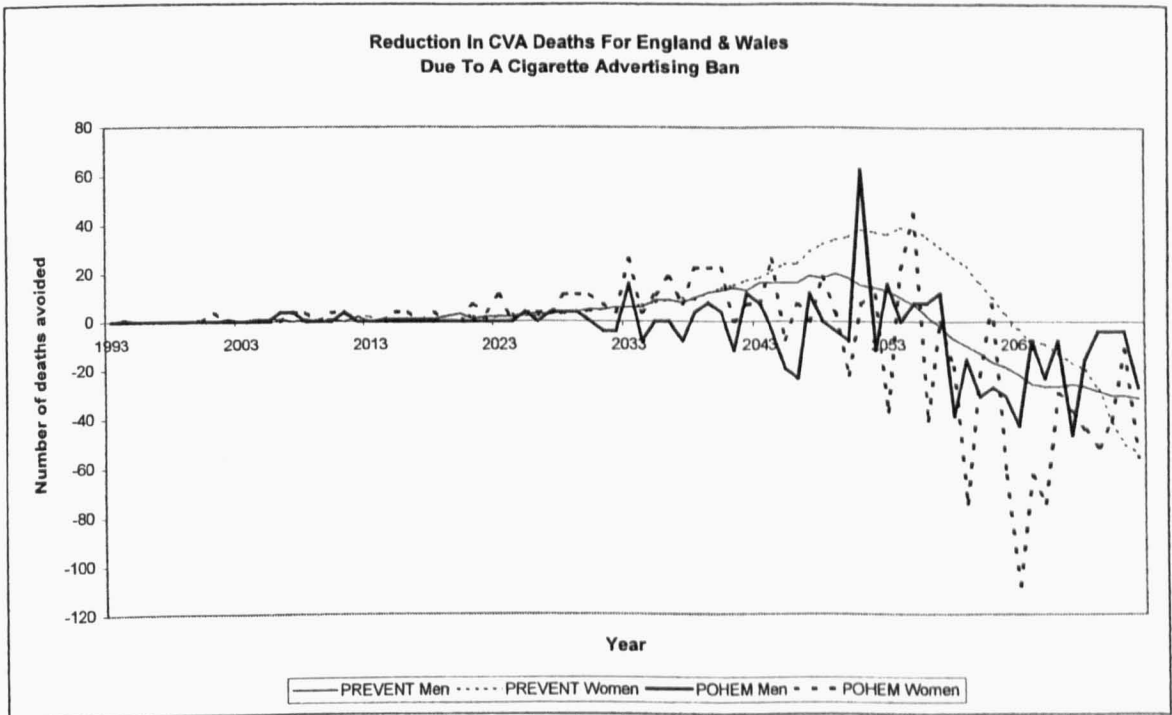

Figure 15.3 - Reduction in CVA deaths for England & Wales due to a cigarette advertising ban: Prevent Model versus POHEM

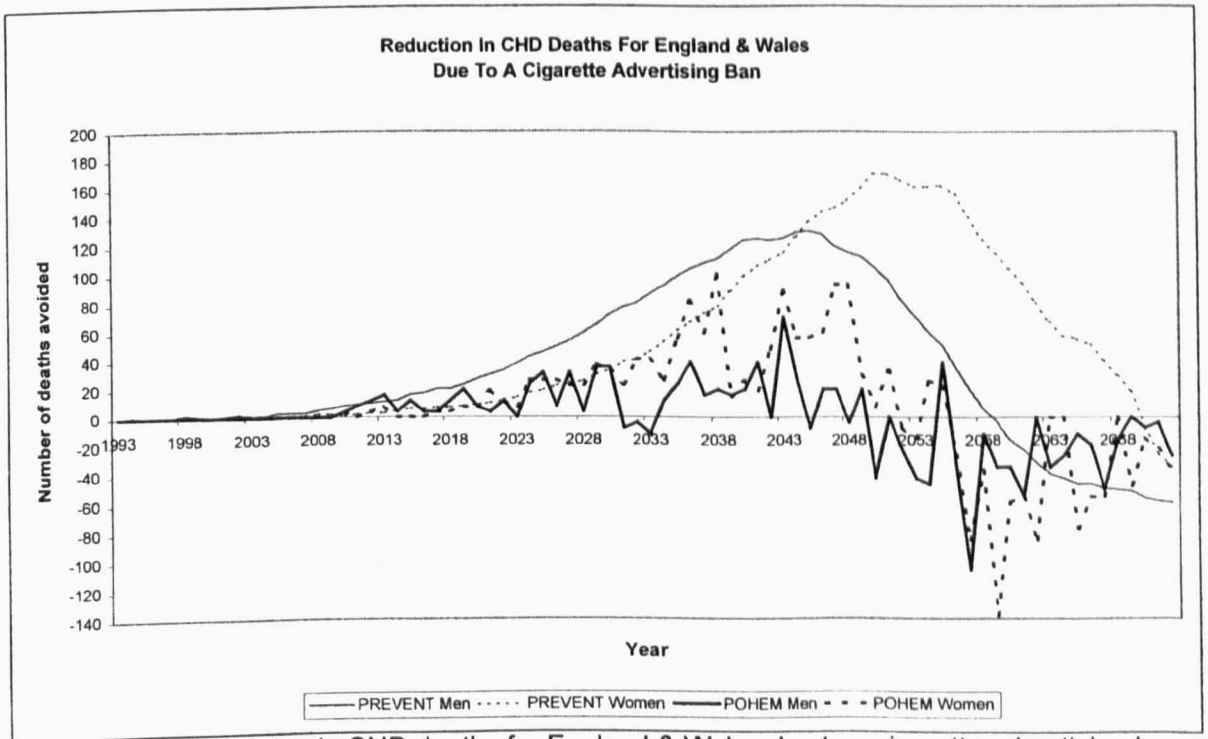

Figure 15.4 - Reduction in CHD deaths for England & Wales due to a cigarette advertising ban: Prevent Model versus POHEM

15.7 Second Adaptation of POHEM

Since the new version of Prevent was unusable for the comparison, I next considered using an older version of the model. However, due to the restrictions of the original Prevent model, with respect to the number of age groups and the maximum LAG time allowed, it would not be possible to implement the updated risk factor information, which now requires 10 age group divisions and a LAG time of 30 years. The next possible solution would have been to convert POHEM to conform with the original version of Prevent, but I felt this would have been a step backwards, especially having spent a considerable amount of time and effort in updating the Prevent input data. In addition, it was felt that it would require a considerable amount of work for Statistics Canada, which may not have been possible in the short time available, to produce a model that would only be used once, and so this solution was decided against.

Finally I decided on comparing the version of POHEM with the Prevent methodology with the a version of POHEM which used the Framingham equation for CHD events, cancer incidence rates for England, and the Prevent methodology for CVA and COLD since these disease were not currently implemented in POHEM. I had also by this stage realised that a comparison of the two epidemiological methodologies was the aspect of most interest to my work, since these would essentially dictate the differences in the number of deaths postponed and the relative importance of each disease modelled between the two models. In addition, comparing the two models' implementation could be achieved without having to compare the same interventions simulated by each model.

In the rest of this chapter I will refer to the version of POHEM that uses the Prevent methodology as the Prevent methodology model, and the version of POHEM that uses the Framingham equation, lung cancer incidence and Prevent relative risks for COLD and CVA as the Framingham methodology model.

15.8 Results from the Second Adaptation

Although for the Biomed Project the comparisons between Prevent and POHEM were run for both the England & Wales and Denmark populations; this chapter will only discuss the comparison using the England & Wales population since I was not involved with preparing the Danish data.

15.8.1 Comparing POHEM and Prevent Methodologies

Figures 15.5, 15.6, 15.7 and 15.8 show the yearly disease specific mortality output resulting from the cigarette advertising ban simulation from the two versions of POHEM by sex. For lung cancer, COLD and CVA both methodologies produced similar shaped curves, with approximately corresponding peaks for yearly deaths postponed by year. While for CHD the Prevent methodology produced a peak in yearly deaths postponed at about 2043, while the Framingham methodology resulted in a slight rise in deaths postponed, with an excess in deaths from about 2043, and then producing a similar pattern of excess deaths to the Prevent methodology for the rest of the simulation period. I discuss the reasons for these differences in section 15.9 Discussion of Results.

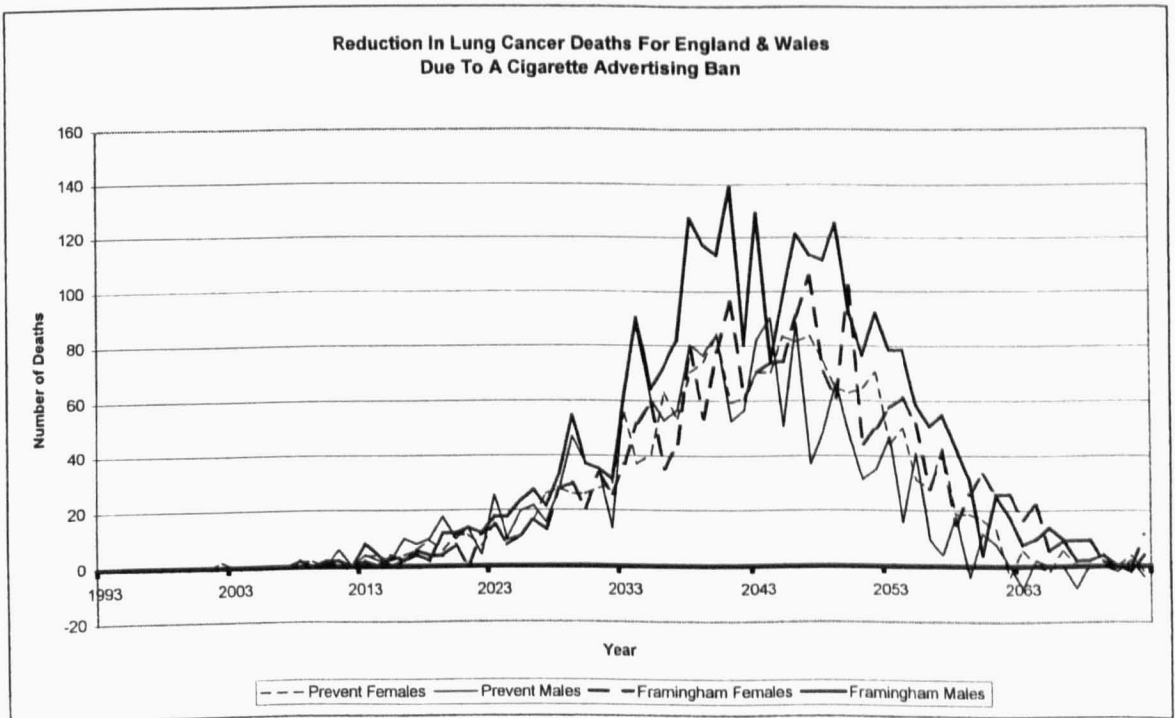

Figure 15.5 - Reduction in lung cancer deaths for England & Wales due to a cigarette advertising ban: Prevent versus POHEM methodology

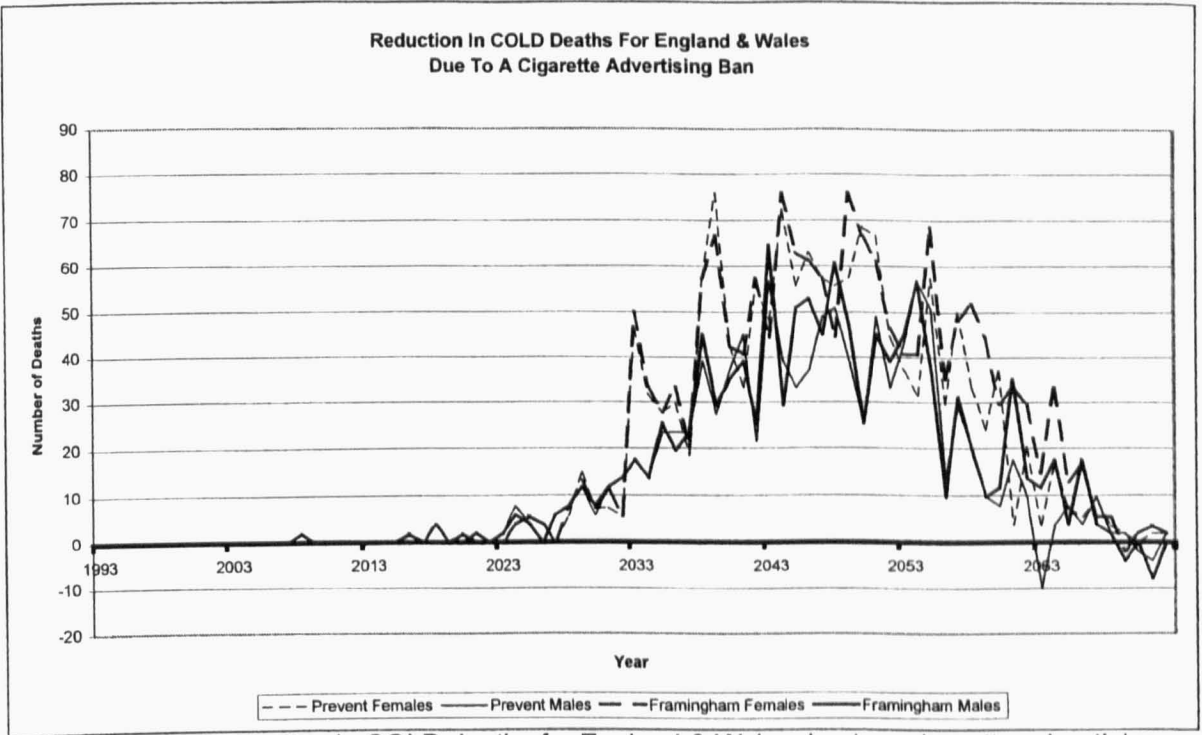

Figure 15.6 - Reduction in COLD deaths for England & Wales due to a cigarette advertising ban: Prevent versus POHEM methodology

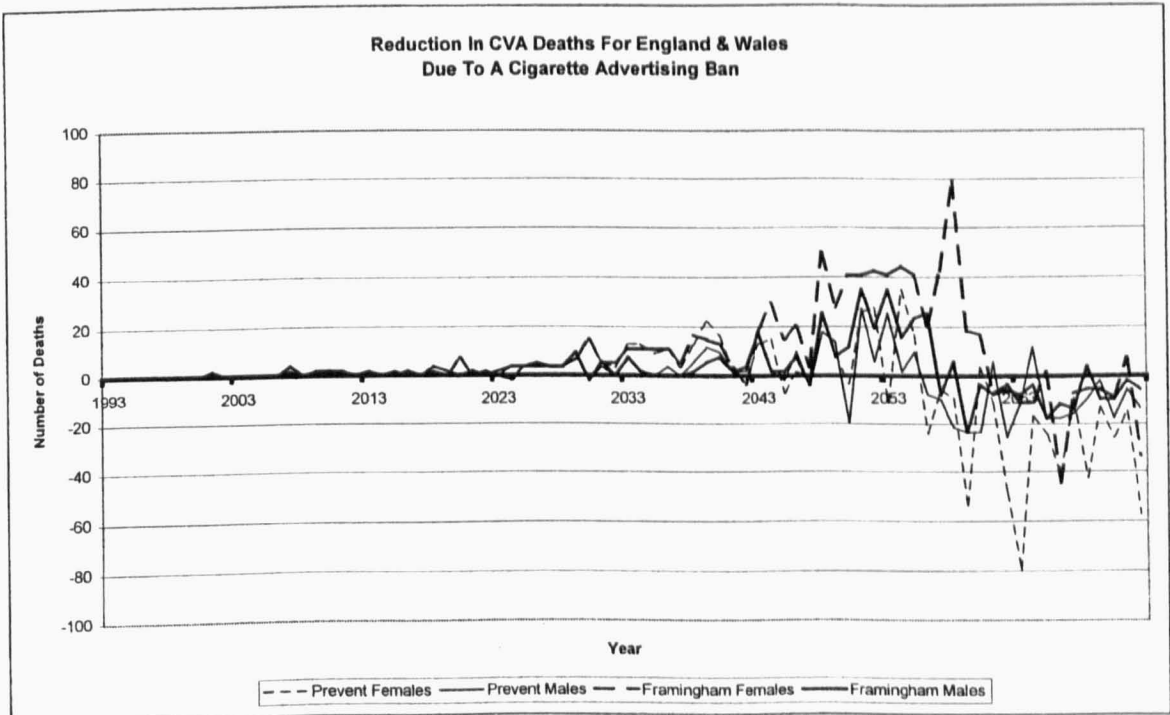

Figure 15.7 - Reduction in CVA deaths for England & Wales due to a cigarette advertising ban: Prevent versus POHEM methodology

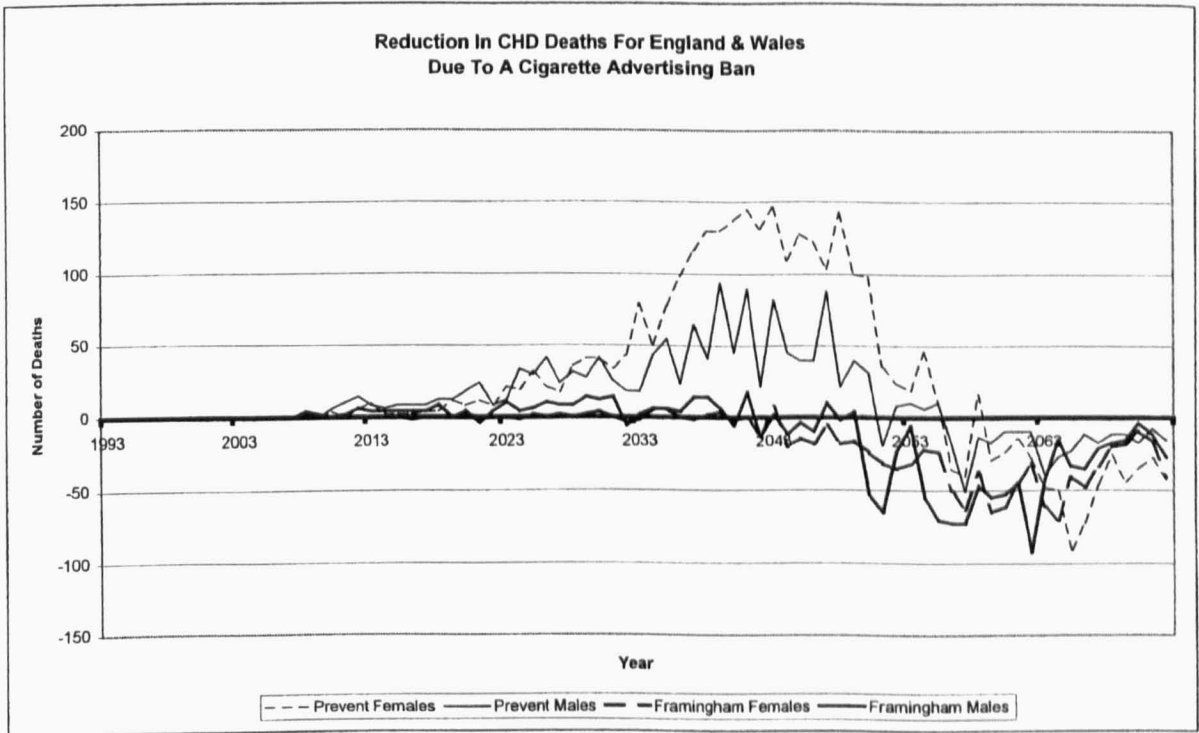

Figure 15.8 - Reduction in CHD deaths for England & Wales due to a cigarette advertising ban: Prevent versus POHEM methodology

The cumulative output for the whole of the simulation period is presented in Table 15.1 for each methodology by sex. Columns 2, 4, 6 and 8 represent the male and female reference cohorts which evolve without intervention, while columns 3, 5, 7 and 9 represent the changes due to the intervention. Negative numbers represent a decrease and positive numbers represent an increase in numbers from the reference cohorts, while the figures in bold signify that the difference from the reference population is statistically significant, using 95% confidence intervals.

For males the Framingham methodology model resulted in 46 more deaths being postponed for CHD than by using the Prevent methodology model. For CVA, the Framingham methodology model resulted in 96 deaths postponed, as opposed to an excess of three deaths with the Prevent methodology model, which was not statistically significant. For both models the intervention resulted in deaths postponed for lung cancer, but the Framingham methodology models produced nearly twice as many deaths postponed (1456) compared to the Prevent methodology model (879). However, for CHD the Prevent methodology model produced 513 deaths postponed, while the Framingham methodology model produced an excess of 396 deaths.

A similar pattern was seen among females. With the Framingham methodology model 88 more deaths were postponed for COLD than with the Prevent methodology model, while for CVA the Framingham methodology model resulted in deaths postponed (340), as opposed to 83 excess deaths using the Prevent methodology model. The Framingham methodology model produced a slightly higher number of lung cancer deaths postponed (81) than the Prevent methodology model, and for CHD the Prevent methodology model produced 1032 deaths postponed, while simulating the intervention with the Framingham methodology model resulted in 521 excess deaths.

15.8.2 POHEM Specific Interventions

The cumulative outputs by sex for the high risk and population interventions are presented in Table 15.2 for the whole simulation period. Columns 2 and 5 represent the male and female reference cohorts which evolve without intervention, while columns 3, 4, 6 and 7 represent the changes due to the interventions. Again negative numbers represent a decrease and positive numbers represent an increase in numbers from the reference cohorts, and the figures in bold signify that the difference from the reference population is statistically significant.

The high risk intervention would result in only 3.5% of males and 1.8% of females being intervened on at age 50. For both males and females the intervention would result in deaths postponed from CHD and CVA, and an excess of deaths from lung cancer and COLD. The greatest number of deaths postponed would be from CHD, with 1431 and 426 deaths postponed for males and females respectively, while a similar number of CVA deaths would be postponed on both sexes, 283 for males and 265 for females. The intervention would result in a smaller number of excess deaths in females than males, with 22 females COLD deaths compared to 142 males deaths, and an excess of 21 female lung cancer deaths compared to 145 for males. For all diseases, and both sexes, there would be an increase in the average age at death.

In terms of the effect on morbidity, disease incidences reflected disease mortality, as would be expected. The decrease in CHD deaths results from a decrease in CHD cases, and the increase in lung cancer deaths results from an increase in lung cancer cases, for

both males and females. For both diseases there would be increases in the average age of onset for both sexes, while for CHD there would be an increase in the average years lived with the disease, again for males and females.

The population intervention would target 100% of the cohort, and would result in deaths postponed from lung cancer, CHD and stroke for both males and females, while there would be a reduction in COLD deaths for females (-576) and an excess in these deaths for males (+530). The greatest number of deaths postponed would be from CHD, with 8714 and 5081 deaths postponed for males and females respectively. The next largest reduction would be from CVA deaths postponed, with more females benefiting than males, 1498 to 708 deaths postponed respectively. This would also be the case for lung cancer deaths postponed, with 941 for females and 665 for males. In addition, there would be an increase in the average age of disease onset for lung cancer, CHD, CVA and COLD.

In terms of the effect on morbidity of the interventions, for both males and females, there would be a decrease in the averaged age of disease onset for lung cancer, while there would be an increase for CHD. For both these diseases there would be an increase in the average number of years lived with the diseases, for both sexes.

POHEM Simulations Output For England & Wales													
Sex	Methodology Models	Males						Females					
		Prevent			Framingham			Prevent			Framingham		
		Reference	Ad Ban (difference)	Reference	Ad Ban (difference)	Reference	Ad Ban (difference)	Reference	Ad Ban (difference)	Reference	Ad Ban (difference)		
	Persons (who live at least to age 15)	989542	0	989542	0	992310	0	992310	0	992305	0		
	Persons alive at 70	697081	1094	696721	908	807909	1541	807930	1541	807930	771		
	Persons alive at 85	213523	1205	211971	1089	391094	2192	388743	2192	388743	1355		
	Smokers at age 20	34.0%	0.0%	34.0%	0.0%	36.0%	0.0%	36.0%	0.0%	36.0%	0.0%		
	Proportion prevented by ad ban	0.00	2.0%	0.00	2.0%	0.0%	2.2%	0.00	2.2%	0.00	2.2%		
	Life expectancy	74.66	0.04	74.62	0.03	79.82	0.06	79.77	0.06	79.77	0.04		
	Lung cancer cases	82383	-979	79889	-1608	39639	-1126	38547	-1126	38547	-1211		
	Average age lung cancer onset	71.56	0.06	71.24	0.02	70.97	0.05	70.82	0.05	70.82	-0.02		
	Average years lived with lung cancer	1.32	0.00	1.33	0.00	1.52	0.00	1.59	0.00	1.59	0.00		
	LUNG CANCER deaths	73307	-879	71351	-1456	35856	-1015	34849	-1015	34849	-1096		
	Average age LUNG CANCER death	71.81	0.06	71.55	0.02	71.34	0.05	71.21	0.05	71.21	-0.02		
	CHD cases	513945	-1305	511041	89	498553	-2637	490741	-2637	490741	872		
	Average age CHD onset	65.85	0.06	65.72	0.03	74.51	0.18	74.31	0.18	74.31	0.02		
	Average years lived with CHD	11.04	-0.02	11.21	-0.01	9.47	-0.08	9.79	-0.08	9.79	0.00		
	CHD deaths	268515	-513	269532	395	208518	-1032	208483	-1032	208483	521		
	Average age CHD deaths	74.01	0.04	73.99	0.03	80.23	0.10	80.14	0.10	80.14	0.02		
	CVA deaths	91440	3	93213	-96	140216	83	144216	83	144216	-340		
	Average age CVA deaths	78.30	0.03	78.38	0.02	82.58	0.04	82.63	0.04	82.63	0.03		
	COLD deaths	64772	-528	66540	-574	33946	-780	35523	-780	35523	-868		
	Average age COLD deaths	77.76	0.04	77.80	0.04	77.17	0.08	77.36	0.08	77.36	0.07		

Columns 2, 4, 6 and 8 represent the male and female reference cohorts which evolve without intervention, while columns 3, 5, 7 and 9 represent the changes due to the intervention. Negative numbers represent a decrease and positive numbers represent an increase in numbers from the reference cohorts, while the figures in bold signify that the difference from the reference population is statistically significant, using 95% confidence intervals.

Table 15.1: POHEM simulation output of a cigarette advertising ban using the Prevent and Framingham methodology models

POHEM Simulations Output For England & Wales							
Sex	Intervention Modelled	Males			Females		
		Reference	High Risk (difference)	Population (difference)	Reference	High Risk (difference)	Population (difference)
	Persons (who live at least to age 15)	989542	0	0	992305	0	0
	Persons alive at 70	696721	1232	5883	807930	315	2531
	Persons alive at 85	211971	940	6195	388743	638	6147
	Proportion affected by intervention	0.0%	3.5%	100.0%	0.0%	1.8%	100.0%
	Life expectancy	74.62	0.04	0.21	79.77	0.01	0.15
	Lung cancer cases	79889	152	-734	38547	18	-1057
	Average age lung cancer onset	71.24	0.02	0.11	70.82	0.01	0.02
	Average years lived with lung cancer	1.33	0.00	0.00	1.59	0.00	0.00
	LUNG CANCER deaths	71351	145	-665	34849	21	-941
	Average age LUNG CANCER death	71.55	0.02	0.11	71.21	0.01	0.03
	CHD cases	511041	-3202	-17631	490741	-1258	-12342
	Average age CHD onset	65.72	0.09	0.48	74.31	0.03	0.32
	Average years lived with CHD	11.21	-0.03	-0.23	9.79	-0.01	-0.12
	CHD deaths	269532	-1431	-8714	208483	-426	-5081
	Average age CHD deaths	73.99	0.07	0.27	80.14	0.02	0.19
	CVA deaths	93213	-265	-708	144216	-283	-1498
	Average age CVA deaths	78.38	0.05	0.20	82.63	0.03	0.15
	COLD deaths	66540	142	530	35523	22	-576
	Average age COLD deaths	77.80	0.02	0.12	77.36	0.02	0.14

Columns 2 and 5 represent the male and female reference cohorts which evolve without intervention, while columns 3, 4, 6 and 7 represent the changes due to the interventions. Negative numbers represent a decrease and positive numbers represent an increase in numbers from the reference cohorts, and the figures in bold signify that the difference from the reference population is statistically significant.

Table 15.2: POHEM simulation output of high risk and population intervention strategies

15.9 Discussion of Results

15.9.1 Comparing POHEM and Prevent Methodologies

The two models produced similar patterns for the yearly disease specific mortality over time for lung cancer, CVA and COLD, although there are differences in the magnitude of the number of deaths. The pattern for COLD deaths are similar in magnitude across both models since they both used the Prevent methodology for this disease, and smoking was the only risk factor associated with COLD. The Framingham methodology resulted in more lung cancer deaths postponed for males and females than the Prevent methodology model. This is probably due to the Prevent methodology using the Prevent relative risks of lung cancer mortality to generate lung cancer incidence, while the Framingham methodology uses actual lung cancer incidence data. Since the majority of individuals with lung cancer will die from the disease, one can argue use mortality as a proxy for incidence; the Framingham methodology model is probably more realistic.

The most marked difference in deaths between the models were for CHD and CVA. The Framingham methodology model had only a small effect on preventing CHD deaths and a greater effect on CVA deaths, and so showed an excess of CHD deaths. On the other hand, the Prevent methodology model had a greater effect on CHD deaths than CVA, and so resulted in an excess of CVA deaths, but only slightly. In the Prevent methodology model the intervention has more effect on CHD than CVA since the relative risks of CHD mortality due to smoking are higher than for CVA up to the age of 75 years.

This difference in the importance of CHD and CVA with respect to smoking in each model is a result of the interaction between the Framingham equation, used for CHD events, and the Prevent methodology, used for CVA events, in the Framingham methodology model. Since the model uses the assumption that the progression from incidence to mortality was immediate for CVA; it means that the intervention has a greater effect on CVA as there is no morbidity period within which an individual can be at risk from other diseases. The output of the models are presented for the life-spans of

the synthetic cohorts; so a reduction in deaths from one disease will lead to an excess in deaths from other diseases.

15.9.2 POHEM Specific Interventions

In the high risk intervention strategy a much smaller number of individuals were intervened on, only 3.5% of males and 1.8% of females in the cohort. The high risk strategy resulted in deaths postponed from CHD and CVA, with an excess of deaths from lung cancer and COLD. This is due the reductions in hypertension and hypercholesterolaemia, which have an immediate effect on CHD and CVA, while the effect of the reductions in smoking on COLD and lung cancer take longer to produce an effect. This leads to an increase in deaths from these causes among those at high risk. The high risk strategy had a smaller effect than the population strategy, probably because so few people qualified for the intervention.

In contrast the population strategy intervened on 100% of individuals in the cohort, and resulted in an increase in the number of persons alive to age 70 and 80, average age of death, reductions in CHD and lung cancer cases and deaths, CVA deaths for both sexes, as well as a reduction in COLD deaths in females, although there was an increase in these deaths for males.

The difference between males and females in deaths from COLD may be due to the interaction between the Framingham equation used for CHD events and the Prevent methodology for CVA and COLD events using the Framingham methodology model. Males have a high probability of CHD, as derived from the Framingham equation, and so interventions that target all the CHD risk factors in the equation will have a greater effect in the reduction of CHD in males than females. More males will then be at risk from other diseases related to these risk factors. In the model CVA is influenced by blood pressure and smoking, whereas lung cancer and COLD are only influenced by smoking. The Prevent methodology gives CVA a stronger influence on mortality, with the progression from incidence to death being immediate, and so the result is an excess in CVA deaths for males.

Of the two POHEM specific interventions the population based strategy would produce the most health gain, even though the shift in risk factor prevalences were small, since it affected the whole cohort, whereas the other interventions only targeted a very small percentages of the cohorts. This reflects and reinforces Rose's argument that preventive strategies which concentrate on a minority at high risk produce less health gain than strategies which intervene across the whole population, since the minority at high risk contribute a small proportion of adverse events (Rose 1992). The effects of the high risk strategy could be improved by reducing the values of cholesterol and diastolic pressure levels at which individuals would be intervened at, and by reducing the age at which the intervention would begin. These changes to the high risk strategy would increase the number of individuals within the cohort affected by the intervention, and would increase the time those individuals would be affected for. An area of further work would be to investigate the risk factor levels and the age groups that high risk strategies would need be targeted to produce similar effects as population strategies.

15.10 Discussion

Although it was not possible to use the Prevent model for a direct comparison with POHEM; it is still possible to compare the performance and output of the two models in terms of the objectives of the Biomed project from using the models separately, with respect to:

- Data needs,
- Generalising and adapting the models for different populations,
- Flexibility in addressing additional questions,
- Interpretation.

15.10.1 Data Needs

The data needs of Prevent and POHEM are very similar, particular in terms of population and mortality data. The most marked difference between the data sets of the two models is that POHEM requires risk factor data in the multivariate form, while Prevent uses univariate distributions. Univariate distributions of risk factors by age and

sex are usually produced in reports, such as those for the General Household Survey and the Health Survey for England, whereas producing multivariate risk factor distributions by age and sex will require access to the raw data from such surveys, which will then need to be reanalysed. These data must also be reanalysed to calculate the univariate mean and standard deviation for each risk factor distribution by age and sex, which are require for input to POHEM. Other data needs of POHEM that are additional to those of Prevent are lung cancer incidence and survival by stage, sex and age group.

15.10.2 Generalising and Adapting the Models for Different Populations

The generalisability and adaptability of both models are highly dependent on the availability and generalisability of their input data. If the required input data are not available, or possible to derive, for the new population, as for example the use of Prevent Plus as discussed in Chapter 10, then it will not be possible to produce a version of a model. Secondly, the user must decide if the model's methodology and the data used by this methodology, such as the relative risks of mortality in Prevent and the Framingham equation in POHEM, can be applied to the population of interest. With respect to both of these issues my work has involved considering the suitability of applying these to the population of England & Wales, as detailed in Chapters 7, 9 and 14.

15.10.3 Flexibility in Addressing Additional Questions

Of the two models POHEM is the most flexible with respect to addressing additional policy questions. Not only is it possible to simulate high risk and population interventions strategies with POHEM, which are not possible with Prevent, but it also has the ability to include Prevent's methodology into its structure, as detailed in this chapter. This flexibility and adaptability allowed me to compare the face-validity of the outputs of the two models, and so discover an error in Prevent that its developers were unaware of.

15.10.4 Interpretation

Conceptually the results of Prevent may be easier to interpret, since one applies interventions to the whole, or part of a real population, then monitors the development of this population over time. With POHEM one has to understand that interventions are applied just to one cohort, which is monitored over time, and this then requires the user to employ some method for applying the results from the artificial cohort to their real population. However, for both models the user must have a good understanding of their methodologies and input data in order to interpret their results.

The stochastic nature of POHEM's output when producing yearly events results in jagged graphs which may be confusing for policymakers to interpret, particularly if one year there are events postponed and the next there is an excess of events when compared to the reference cohort. On the other hand, Prevent's results can be used to produce smooth curves, which are more intuitive to follow, since there are no sharp changes in the signs of values, as with POHEM. Consequently one needs to consider how best to present POHEM's results clearly. It is clearer to present results from POHEM in the form of tables, such as Tables 15.1 and 15.2. However, it may have been more informative to produce results in terms of premature deaths postponed, possibly concentrating on deaths before 75, since a reduction in deaths from one disease will always lead to an excess in deaths from other diseases if the output are presented for the whole life-span of the synthetic cohort.

15.10.5 General Discussion

Comparing two models that have different methods of implementation and methodologies is a difficult task, even with my work in which I have had the methodology of one model transposed into the structure of another.

There is no gold standard for comparison. Neither methodology can be validated, or classified as producing a "right" answer. This means that in order to interpret the output produced by the two models one needs to have a good understanding of the assumptions and the methodologies used, the data input, the disease epidemiology, the simulation

processes, the translation of the intervention to the modelling environment and the data output processes. In comparing the models it is not possible to say that one model is right and another is wrong, or even that one model is better than another. However, it is important to be able to explain why different models produce different results, and how the factors responsible for these differences affect a model's results. Unfortunately this kind of knowledge is not easy to obtain, and can only be gained with experience of the whole modelling process.

15.11 Reflections

Originally I hoped to be able to produce and run an England & Wales version of POHEM myself, but due to delays in the redevelopment of POHEM it was not in a state that anyone other than the developers at Statistics Canada could input the data, set up the model, or run the simulations. This meant that running POHEM simulations was dependent on staff at Statistics Canada being free from other work commitments. To a certain extent, this limited the scope of the work with POHEM, since it was not possible for me to investigate the effect of targeting different risk factor and age groups, or the impact of different assumptions concern risk factor/disease relationships in the time available, as I have done with Prevent.

In addition, the fault in the Prevent model meant that it was not possible to make a full comparison of the two models; only a comparison of the two models' methodologies within the POHEM framework could be made. Since POHEM had the ability to incorporate the methodology of Prevent, I was able to identify the fault. This could be a use of flexible models such as POHEM, to at least validate the implementation of other models, in the absence of being able to validate their results.

The comparison of the two models' methodologies within the POHEM framework suffered from trying to make the two models as similar as possible. The inclusion of CVA and COLD in the Framingham methodology model using the Prevent methodology led to the increased importance of these diseases when interacting with the model's original methodology. It would have made for a clearer comparison if CVA and COLD had been excluded from POHEM, concentrating on the effect of interventions on

CHD and lung cancer. However, this statement can only be made with hindsight since the other Biomed members who developed Prevent wanted these diseases included in the comparison.

Having gone through the process of trying to compare two models I do not think that much can be learnt from comparing the results of simulating the same intervention with such models. Ultimately users will chose a model that can simulate the interventions that policymakers want simulated. I would not choose Prevent to model a high risk strategy, or POHEM if I wanted to investigate the effect of an interventions with the demographic development of the whole of the England & Wales population, since each models cannot simulate these interventions, but the other can. What this work has highlighted is the need for those who use models to be able to explain why different models may produce different results.

15.12 Conclusions

As mentioned earlier in the chapter POHEM and Prevent are quite different models, aside from the macro/micro-simulation distinction, with regard to how they model interventions and the type of interventions they can simulated. Consequently one cannot say that one model is better than the other, but rather that Prevent is better suited for simulating interventions in conjunction with the demographic evolution of a population in terms of mortality, while POHEM is best suited for modelling interventions that simulate high risk and population strategies in terms of morbidity and mortality. Therefore the type of intervention one wishes to simulate will dictate the type of model one will use, rather than one being able to simulate any intervention using any model. Ultimately the user must be able to explain why different models may produce different results.

15.13 Summary

This chapter describes my work on phase three of the BIOMED II project on Public Health Models, the aim of which was to compare a micro-simulation model, POHEM,

to a cell-based model, Prevent. A number of other differences between the two models, aside from the different approaches to simulation, are also discussed.

Unfortunately, due to a fault in the updated version of Prevent, it was not possible to compare the models directly. Instead the Prevent methodology was transposed to the POHEM framework, and then the two models' methodologies were compared within the POHEM framework. This comparison was made simulating the effects of the cigarette advertising ban detailed in Chapter 9. In addition, the chapter describes how POHEM can be used to simulate risk factor interventions that use high risk and population strategies, involving a shift in risk factor distributions, which are not possible with Prevent.

Chapter 16 – POHEM Discussion

16.1 Introduction

In the last couple of chapters I have described my work with POHEM. Although I have used the model less extensively than the Prevent model my experiences of using it have still given me an insight to its usability as a policy tool. POHEM is a technically, methodologically and computationally complex model, which is reflected in the effort needed to understand and use the model.

As with the Prevent model, POHEM has some positive and negative aspects in terms of its use as a model for public health policymaking, and these aspects will affect how it can be used and what it can be used for. Within this chapter I discuss these aspects with regard to how important I feel they are in affecting the model's usability, as I have with the Prevent model in Chapter 11.

16.2 Positive Aspects of POHEM

Some of the positive aspects of POHEM were highlighted in the last chapter in which it was compared to the Prevent model, particularly with respect to POHEM being able to simulate certain strategies that I consider important to public health policy, which Prevent cannot do. The first of these aspects is POHEM's ability to shift risk factor distributions, and so simulate the effect of population interventions. The example given in Chapter 11 of a health promotion policy aimed at lowering the population's cholesterol level, which would shift the distribution of cholesterol level across the whole population to a lower level, is possible to simulate with POHEM. POHEM's ability to model this type of intervention was demonstrated in Chapter 15 by simulating an intervention that reduced cholesterol levels by 2%, reduced diastolic blood pressure by 2 mm Hg and reduced the number of smokers by 6%.

Secondly, since the model holds risk factor prevalence data as multivariate distributions it allows a user to target individuals who have a cluster of risk factors, and so allows one to simulate high risk intervention strategies, unlike Prevent. This was demonstrated

by a simulation described in Chapter 15 where individuals who smoked, had cholesterol levels greater than 260 mg/dl, and diastolic blood pressure levels greater than 95 mmHg were targeted at 50 years of age.

And thirdly, POHEM's use of the Framingham equation for CHD incident events and of available cancer incidents data allows it to generate morbidity measures, as well as output in terms of mortality. This is a particularly important aspect. I have shown with my modelling with Prevent of physical activity targets and the Birmingham population that for many risk factor interventions the effects are very small in terms of the number of deaths avoided. Therefore, by including morbidity, with POHEM it would be possible to present policymakers with a more complete picture of the effect of an intervention. Although not covered in this thesis, the model has the ability to include costs, and so one would be able to present some measure of the relative cost-effectiveness of various interventions.

Another positive aspect of POHEM is its flexible structure which allows the methodologies of other models, such as Prevent, to be implemented into the POHEM architecture. This enables one to test other models, as detailed in Chapter 15. I was able to compare the face-validity of the outputs of the two models, and to discover an error in Prevent that may otherwise have gone unnoticed for some time by its developers. This also illustrates how POHEM, like Prevent, can be used for hypothesis testing, since the model's flexibility allows the user to investigate how changing various assumptions concerning the risk factor and disease relationship within the model will affect the outcomes of an intervention.

POHEM usability as a policy tool is greatly enhanced by its ability to model up to ten different simulations per run, which allows the user to carry out sensitivity analysis of the input variables. Although this is possible in Prevent, it would require each sensitivity run to be simulated separately. In addition, POHEM generates confidence intervals and tests for statistical significance of its results.

Even though POHEM was originally developed from an actuarial model, written in an out of date language, Statistic Canada's long term interest in modelling has meant that

they have committed resources to its development and usability. This was shown by their conversion of the model's source code from APL to MODGEN, the C++ like language used by all the models in its Health Analysis and Modelling group. This has meant that the model is understood and can be developed by a number of people, and so, unlike Prevent, does not rely on a single individual. This need to make POHEM more accessible has meant that the methodology and coding has had to be well documented. Not only can new people joining Statistics Canada understand and use the model, but it also allows greater accessibility to those outside the institution.

16.3 Limitations of POHEM

Although POHEM has many advantages over the Prevent model; there are some aspects where Prevent uses methodologies more appropriate for policymaking. The most notable of these is that while Prevent can simulate the development of the whole population; POHEM can only simulate the development of one birth cohort over time, although the cohort can be intervened on at any point in its life span. One would have to run POHEM for each birth cohort, each simulated for a different length of time, to build up a population profile.

In addition, the age dependent risk factor prevalence data used by the model is derived from cross-sectional surveys. This means that as the simulated cohort ages it takes the age specific risk profiles of the population the data is derived from. This may be true for age dependent risk factors such as blood pressure or cholesterol, but will not be so for behavioural risk factors such as physical activity or smoking. This has implications if one is trying to build up a population from cohorts. Within POHEM one is using the assumption that changes in risk factor distribution as a cohort ages will be the same for all cohorts as they pass through the same age groups, which may not be true due to cohort or period effects.

POHEM, in comparison to Prevent, is more computationally intensive, with one reference simulation and one intervention simulation each of 4 million individual taking as long as sixteen and a half hours when run on a dual Pentium II 266Mhz with 132Mb DRAM, although simulations of about 100,000 individuals only take about fifteen

minutes. The three scenarios simulated in Chapter 13 would have taken over 66 hours to run had I used a 4 million person cohort. Eventually this will be come less of a problem as the computational power of affordable and readily available computers increases over time, but presently the time taken to run simulations may prove to be a barrier to POHEM's use as a policy tool. This would be a particular problem if one was to try to build a population by generating each cohort.

Unlike Prevent, POHEM is a very technical model without a "user-friendly" interface. In order to run simulations the user must edit the model's MODGEN source code, compile the MODGEN source code to C++ source code, next compile the C++ source code into an executable file, and then run this file. Although, the developers are adding Windows interfaces to make the model more user-friendly it is not seen as a priority for Statistics Canada. As a consequence I have had to rely on staff from Statistics Canada to input the data and run the model for me. Although in the long term I will be able to use the model without relying so heavily on Statistics Canada; the investment in time and effort may be a barrier to using the model as a policy tool, especially when policy questions need to be answered in a shorter time-scale.

Although Statistics Canada are committed to the long term development of POHEM it has taken a long time to reach its current stage of development. The conversion from APL has taken well over three years to complete. At times, Statistics Canada had to halt development of the new version and use the APL version in order to deliver simulations addressing current governmental policies. This longer than expected development time was also one of the factors contributing to the difficulty of its use by others outside Statistics Canada, since each updated version had different features and mechanisms for setting up and running the model, and so one needed to wait for some stability in the methodology used before embarking on learning to use the model.

Another aspect of POHEM which could be seen as a barrier to its use as a policy tool is that care needs to be taken in presenting the output from the model. As seen in Chapter 15, the stochastic nature of the model's output when producing yearly events results in jagged graphs, which may be confusing for policymakers to interpret, particularly if one year there maybe events avoided and the next there is an excess of events when

compared to the reference cohort. Consequently one needs to consider how best to present POHEM's results clearly. This is true for any model, but more so for the stochastic output of micro-simulation models.

16.4 Conclusions

The flexibility and complexity of POHEM can be viewed as both strengths and weaknesses of the model. They give POHEM the ability to simulate interventions that are impossible to model with Prevent, especially the ability to simulate and compare high risk and population strategies, which are important issues in public health policy. In addition, POHEM's ability to incorporate multiple methodologies make it a powerful tool for testing the output of other models, as well as being adaptable to include any process that a modeller may wish to simulate. However, these aspects also make the model highly technical. The user must understand the source code and compilation processes of the model to use the model without the assistance of its developers.

The model is even more complex than Prevent, and so, like Prevent, is too complex be used by policymakers on their own. However, unlike Prevent, the model require a greater commitment, in terms of time and effort, by others modellers who wish to use it. Modellers still need to fully understand its workings and its input data, in order to translate POHEM's results to policymakers. Fortunately the implementation methodology used by POHEM is common to all the models used by the Health Analysis and Modelling group at Statistics Canada, and so it is well supported in terms of its documentation and the number of people who can advise on the model. This makes it easier for those outside Statistics Canada to develop and use the model. However, policymakers may not realise the time and effort needed before one is able to use it, and so may not be prepared to invest the necessary resources to the model.

POHEM still has a number of limitations that cause it to fall short as an ideal model for simulating risk factor interventions for policymaking. Most notably that it can only simulate interventions on a cohort, rather than a population, which I feel is more relevant for policy. The modelling with Prevent in Birmingham (Chapter 8) showed

how the demographics of a population contributed to the effect of an intervention, as well as the risk factor profiles of the cohorts in that population.

This limitation is coupled to the computational demands of the model which currently dictates very long simulation run-times for sizeable cohorts. This may be prohibitive in terms of the practicality of simulating whole populations. As technology improves this will become less of a problem, making the possibilities of a population version of POHEM more feasible.

Overall, POHEM is a usable tool for policymaking, since its flexibility allows the implementation of numerous types of interventions, mechanisms and methodologies, although one is limited to applying the simulations to individual birth cohorts. Most importantly users of POHEM need to be aware of its complexities, and of the time and effort they need to invest before they will be able to use the model.

Section 4: Discussion

Chapter 17 - Discussion

17.1 Introduction

The aim of this thesis was to evaluate the use of public health models in policymaking in terms of the appropriateness and the practicalities of using such models for simulating health interventions, and the application of the results of such modelling exercises to public health policymaking. And through this process one would be able to define the requirements for public health models that are capable of addressing the policy agenda.

To this end I have described the adaptation and use of the Prevent and POHEM public health models for simulating the effects of risk factor interventions on CHD in the England & Wales population, particularly the effect of targeting various sections of the population. The results of these modelling exercises were intended to contribute to the debate of setting priorities for reducing CHD and to enable policymakers to make more informed decisions concerning public health strategies.

I have considered the limitations of the input data, the assumptions underlying the methodology of the models, and problems in translating interventions to the simulation environment. In addition, I have discussed the link between research and policy, with respect to the issues that influence the implementation of research findings to the policy agenda, and the need for modellers to be aware of these issues in developing public health models.

Within this chapter I review my work, and then discuss the future role of public health models in policymaking, in terms of how and by whom they should be utilised, and the requirements for producing models that are able to address policy questions.

17.2 Model Development

17.2.1 Review of Models

When I began this work I reviewed several suitable health policy models, particularly ones that included coronary heart disease. I found that non-communicable disease models have been developed in a number of areas such as screening, medical interventions, resource allocation and risk factor reduction. Many such models have concentrated on various forms of cancer, while new infectious disease models have been developed relating to HIV in terms of transmission, incubation, variable infectiousness, and the cost-effectiveness of prevention targeting. Several models for CHD concentrated on such areas as individual risk factors, cardiovascular treatment, secondary care, familial aggregation of disease, priority rating systems and pathways of coronary care, risk estimation and counselling, estimating GP workload, and cardiological treatment.

In the course of reviewing the literature I concluded that the essential characteristics for models that were to simulate public health policy options, derived from Chigan (Chigan 1992), were:

- a time period during which risk factors may develop, latent periods before risk factors affect morbidity and mortality, and lag times during which risk factor changes translate into mortality reduction,
- multi-factorial risk factor/disease relationships, where one risk factor can influence several diseases, and one disease may be influenced by several risk factors,
- a demographic basis by which population changes within the simulation period can be considered.

However, I discovered that few of the models I had identified conformed to these criteria. The ones that matched these criteria the closest were Prevent, the Coronary

Heart Disease Policy Model, NIMPH/TAM, Prevent Plus, the CRISPERS model, POHEM and the Global Burden of Disease model.

After more appraisal of these models I decided to proceed with the Prevent and POHEM models because they conformed to my criteria for being classed as policy models, included CHD as one of the diseases simulated, could be adapted for use with the England & Wales population, and their developers were willing for others to develop their own country versions of the models. In addition, since Prevent was a cell based model and POHEM was a micro-simulation model I could also compare their methodologies.

17.2.2 Prevent

Initially I had intended to improve the input and output of data for the Prevent model by reprogramming it. However, there was no documentation in terms of comment statements in the programme, flow diagrams or variable glossaries to demonstrate how the programme worked. In addition, the variable names used within the programme were abbreviations of Dutch words, and the source code did not followed a structured programming style. Consequently I decided to make the model more easy to use by other, non-programming, changes such as developing a spreadsheet model to calculate risk factor trends, and allowing the movement of individuals from one risk factor exposure category to another, rather than to the non-exposure category.

My work on trends succeeded in clarifying the methods for defining and calculating the risk factor trends input data files for Prevent, as well as giving the developers an opportunity to fully explain the mechanisms by which the trends were used in the model. Documenting this work meant that the principles of calculated trends could be understood and implemented by others.

In the course of my work with Prevent I became aware of its limitations in being unable to shift risk factor exposure, use relative risks less than one and use univariate risk factor distributions. However, I realised these problems after I had used the model for some time, and had tried to simulate interventions suggested by policymakers and other

researchers. I have outlined how I was able to overcome some of these problems, and explained why some problems could not be solved due to the methodology of the model and due to the developers' reluctance to adapt the model.

I modelled changes in physical activity in collaboration with the Health Education Authority. At the time there was a great deal of discussion about setting targets for physical activity, and my work on modelling the effects of increasing activity in the population, targeting differing exercise levels, age and gender groups, contributed to the debate. This work led to my being asked by Birmingham Regional Health Authority to adapt the Prevent model to the Birmingham population. Their interest was in making comparisons between risk factor intervention strategies as a possible aid to policy decision making. In particular they were interested in simulating short term risk factor interventions in the Birmingham, Small Heath and Sutton Coldfield populations. My modelling showed that the interventions that resulted in the most actual years of life gained for all three populations were targeting male smokers and screening for and treating severe hypertension in females.

The Biomed project stressed the need to update a model, seven years after its initial development. In three years the project achieved its aims of validating the models in the context of different E.U. countries, comparing the implementation, the utilisation and the results of Prevent in different E.U. countries, and exchanging data on risk factors, relative risks, new treatments and treatment outcomes, for inclusion in models.

The implementation of the new version of Prevent was less successful; some limitations of the original model were not addressed, and the scarcity of data and the lack of clear methods for deriving these required data have made the Prevent Plus model difficult to transfer to other populations.

Many of the constraints I experienced in the modelling work carried out with Prevent stemmed from the limitations of the model, as outlined in Chapter 6. It was possible to simulate the HEA's physical activity targets, since they only entailed moving individual from one exposure category to one other, but it would have been more realistic to have simulated shifts in the population's average physical activity levels. The more realistic

the simulation of interventions; the more informative to policymakers are the results. This limitation also affected the choice of interventions modelled for Birmingham Regional Health Authority, since Prevent's inability to simulate shifts in risk factor distributions meant the policymakers were constrained in their policy options.

Since Prevent used only univariate risk factor distributions I was not able to simulate the effects of interventions on those people at high risk due to a combination of risk factors. The interventions modelled may have had more effect if targeted at these high risk individuals, and so resulted in different policy implications. Limited targeting, in terms of age and sex, was possible, and this demonstrated how interventions would have different effects in different groups.

Prevent was only able to produce output in terms of mortality, and this made the results of the interventions modelling seem disappointing, as well as underestimating the true effect of the interventions by excluding reductions in morbidity. Ideally, I would have wanted to produce results in terms of both mortality and morbidity, as this would have given a more complete view to policymakers when comparing interventions.

Lack of data also affected the scope of the modelling carried out with Prevent, and this applied at various stages in the modelling process. One important limitation of the data concerned the risk factor prevalences in Birmingham, Coldfield and Small Heath. There was a poor response rate to the local Pulse Survey, which meant that data for Trent and the West Midlands region had to be used. There were also missing variables such as social class and ethnic groups. If these variables had been available, I could have stratified the population by them and then modelled interventions targeted at these groups, thus addressing key issues on the health policy agenda.

A less obvious, but still important problem was the lack of data on the effectiveness of interventions in changing risk factor levels, such as blood pressure or cholesterol, and in changing the proportion of the population which would take up moderate physical activity or quit smoking. For the interventions modelled with Prevent I relied on the policymakers who commissioned the work to suggest the changes to be achieved by the interventions. However, they were not the best source for such information. In

retrospect it would have been better to have carried out a review of the literature to find out the effectiveness of interventions, and what changes in prevalences would have been realistically achievable. With unrealistic estimates of effectiveness, the output of the model may under or over-estimate the effect of interventions, which in turn will result in policy decisions based on incorrect results.

Gaps in knowledge also exist in terms of the relative risk of disease associated with exposure to risk factors. This is highlighted in my discussion of the Berlin and Colditz meta-analysis (Berlin 1990) in Chapter 7. The meta-analysis seemed to be the best available source for the relative risks of CHD mortality by physical activity level, but it was published 10 years ago and so did not include the results of several large physical activity trials that have been published since its publication (Morris 1990, Shaper 1991, and Manson 1999), which need to be included in a new updated meta-analysis. In reviewing my work I feel that in the future one should also use relative risks from such studies as a means of carrying out sensitivity analysis on one's modelling results. Possibly this procedure should be carried out with any modelling work, since there will always be some uncertainty surrounding the effect of risk factors or interventions on disease.

The smoking interventions simulated as part of the Biomed II project, as described in Chapter 9, highlighted the need for policymakers to be involved in the choice of interventions to be simulated. The facts that Prevent could model smoking interventions and we had the required data on smoking for the four participating countries were not enough justification for modelling the interventions described. Ultimately smoking should have first been identified as an area of interest for policymakers, and then those interventions for reducing the prevalence of smoking that policymakers thought were relevant to their populations needed to be addressed. In future, I would always investigate what the important issues for policymakers were before proceeding with any modelling work, as otherwise the work will not be relevant to the policy agenda.

17.2.3 POHEM

I described the POHEM model, in terms of the adaptation of Weinstein's Coronary Heart Disease Policy Model for use in its CHD module. Then I described the building of the England & Wales version of POHEM in terms of its data requirements, running the model, and the output to be produced by the model, as well as discussing the justification for using the Framingham equation with the England & Wales population.

I outlined my work comparing the performance and output of POHEM, a micro-simulation model, to Prevent, a cell-based macro-simulation model. In making such a comparison one must consider a number of differences aside from their different approaches to simulation. These differences were that of a cohort versus a population model, the ability to shift risk factor distributions, multivariate versus univariate risk factor distributions, using the Framingham equation as opposed to relative risks of mortality to generate events, and using current age group trends as opposed to using actual past and hypothetical future trends.

Due to problems with the updated Prevent model I was forced to compare the Prevent methodology transferred to the POHEM framework with the version of POHEM using the Framingham equation. The outputs of each model's simulation of a ban on cigarette advertising were compared in terms of mortality. I demonstrated how in comparing such models it will not be possible to say that one model is better than another, but that one needs to be able to explain why different models may produce different results, and how the factors responsible for these differences affect a model's results.

In addition, I describe my work using the Framingham methodology model to simulate high risk and population based interventions to demonstrate the model's ability to target individuals with a clustering of risk factors and to shift risk factor distributions, and to produce results in terms of morbidity. The simulation of the population based strategy produced the most health gain, thus reinforcing Rose's argument that preventive strategies which concentrate on a minority at high risk produce less health gain than strategies which intervene across the whole population (Rose 1992).

The main limitation of the work on POHEM was the need to use the modellers at Statistics Canada to input data and run the simulations, and so work progressed when it was possible for them to spend time on the model, rather than when the work was needed. This over-reliance on Statistics Canada was a result of the unexpectedly long time-scale for the conversion of POHEM from APL to MODGEN and the numerous updates of the model once this conversion had been completed. These meant that the features and mechanisms for setting up and running the model have only recently stabilised to an extent that allows others to use the model. Ideally I would have wanted a version of POHEM that I could have updated and run myself; unfortunately there was no way of predicting the time the redevelopment would take, but at least in the near future this will be possible.

In the context of the Biomed II project the interventions modelled with POHEM were chosen to mirror one of the Prevent smoking interventions and to demonstrate some of the limitations of Prevent, for which they proved to be adequate. Although the changes in risk factor prevalence that were simulated were taken from the literature, and so could be assumed to be realistic and achievable; the interventions really should have been developed with policymakers to make them more policy relevant. This lack of consultation with policymakers was partly due to the limited time-scale of the project and to POHEM not being completed early on in the project. This meant that it was not possible to show the model to policymakers. In future a demonstration of the model to policymakers, similar to the one of Prevent to Birmingham Regional Health Authority described in Chapter 8, should be undertaken before embarking on the modelling process.

Having concluded that the type of intervention one wishes to simulate will dictate the type of model one will use, I feel that little can be gained from the straight comparison of models, as attempted in Chapter 15, other than highlighting what each model can or cannot do. However, this work did demonstrate how one can try to reproduce the results of one model with another model such as POHEM, which has the flexibility to incorporate the other model's methodology, and so could be used for validating the mathematical processes within the model.

17.2.4 The Role of Policymakers in Model Development

The most important aspect in the development of public health policy models is that policymakers should be consulted at the inception of the model, and should then participate at all the stages of development. They will have more insight than researchers as to what are the important policy issues that need to be addressed, and hence incorporated into a model. In addition, policymakers will then gain a better understanding of such models, and so will be in a better position to commission modelling work, understanding the assumptions and limitations underlying the models, and to understand the output of these models. My experiences with Prevent and Prevent Plus have shown that model developers may not be aware of the importance of certain issues because they have been working in isolation from policymakers. While policymakers may feel that the results from modelling exercises have no relevance to their policy agenda, as seen on the Biomed II project. These problems would be overcome to some extent by having closer links between modellers and policymakers during the development of models.

17.2.5 Other Important Aspects of Model Development

Another important aspect that should be considered in the development of health policy models is the need for information on morbidity, as well as mortality. My experiences with the HEA and Birmingham Regional Health Authority have shown that policymakers will view small changes in mortality as disappointing, even if one states that by excluding morbidity one is underestimating the true effect of the interventions. Producing results in terms of both mortality and morbidity would give policymakers a more complete view when comparing the effects of interventions.

Good documentation is also important in developing a better understanding of a public health model, by policymakers and by other modellers who wish adapt the model to their own population. By documentation I mean literature explaining the workings and assumptions of the model, explaining the data requirements of the model and the assumptions needed to derive data if the required data are unavailable in the correct format, explaining how to use the model, and explaining the programme source code,

which itself should be commented. My experiences with Prevent and Prevent Plus have shown how the lack of documentation has meant that models cannot be easily adapted by other programmers, or used by other modellers. Further development will be almost impossible without considerable time and effort being spent on rediscovering a model's inner workings.

17.3 The Data Need of Models

One of the perceived strengths of public health computer models is that they use available data on risk factor prevalence and population demographics, rather than requiring new data to be collected specifically for the model (Gunning-Schepers 1989). However, different countries have different available data sets, which means that a model developed in one country may not be readily transferable to another country. Mathematical modelling is very data-demanding, and the validity of a model will depend heavily on the data used by it. Modellers need to know which data are available for their populations, and be aware of the quality and applicability of these data.

This idea of using available data for models relies on there being an absolute data set available for any country. Ideally one would want the collection of yearly data on risk factor prevalences, disease incidence and mortality by age, sex, social class, ethnic group and regional grouping. My modelling work has highlighted the need for the regular collection of such health data at a national level. These data are not only vital for use in public health modelling, but also for the monitoring of the Nation's health and for the evaluation of health interventions.

Data on morbidity is difficult to obtain at the population level, and therefore developers need to be aware that the scarcity of such data, and that the lack of reproducible methods for deriving these data can make models untransferable, as with Prevent Plus. Consequently if model developers are to include morbidity they need to use methodologies that can be translated to other populations, and if data need to be derived, then the methods used and the assumptions involved need to be made explicit.

As well as the availability of data, the form in which the data are available is important. If one is to use public health models to address issues such as the effect of intervening on those individuals at high risk, who have a clustering of risk factors, or those of a certain ethnic or socio-economic group, one must be able to identify the number of such individuals in the population in the data and be able to produce risk factor prevalence data in a multivariate format. Consequently, survey data need to be available to modellers in an electronic form, and so allowing them to extract data for the models in any format needed. If they have to rely on just using published tables they will have less flexibility in setting up the categories within the model, and may not be able to address important policy issues such as the effect of ethnicity and socio-economic level. In addition, demographic data need to be in a format that allow modellers to identify individual groups, and ideally one would need to know the risks associated with risk factors in these different groups.

Ultimately to produce accurate CHD public health models one would want annually collected data on the main risks factors for CHD by age and sex, as well as information relating to ethnicity and social class. This is being realised for England with the 1998 Health Survey for England (TSO 2000), which collected information on alcohol consumption, cigarette smoking, eating habits, body mass, blood pressure and blood analyses, including total and HDL cholesterol. However, there are no plans to set up national register of CHD and stroke, as there are for cancer, or to collect data on incidence, prevalence and survival, which would further the development of morbidity modelling. In addition, the Hospital Episode Statistics (DoH 1995) system needs to be improved to allow the identification of patients during and across years so that first and recurrent episodes can be identified, although this may be difficult to achieve due to problems of patient confidentiality.

I have stated that public health policy modelling is very data-demanding, and that the validity of a model will depend heavily on the data used by it. Due to this importance of data to modelling it is essential for modellers to understand the input data for models. The data input process will give modellers a partial insight to the quality of the data, since one has the opportunity to inspect, then organise and stratify the data into the form required by a model, although this would not be the case for those who use a model set

up by others. Although, ideally a modeller would want information on how the data were collected, the response rates, the measurements used, and how representative the data are of their population. Without a proper understanding of a model's input data the user will never be able to fully or intelligently interpret the results their models produce.

17.4 The Policy Arena

My work on modelling began during the period of *The Health of The Nation* (HMSO 1992). At that time it was felt that public health models could be useful in assessing the relative health gain of alternative routes to the attainment of strategic goals, such as *The Health of The Nation* targets. However, over the course of my work in the UK there was a change of government, and hence a change in health policy. The new policy, outlined in *Our Healthier Nation* (DoH 1999), had different aims, areas of priority and health targets. Modellers need to aware that health policy can change over time, and that models need to have the flexibility and adaptability to incorporate such changes if the outputs of such models are to remain relevant to the health policy agenda.

One of my most important conclusions from my work is that models should be only used by modellers who understand their workings and their input data, and should not be used by policymakers alone. Having spent the last five years working on two different models I think that it would be too difficult to translate the assumptions and the methodologies underlying the data input, the epidemiology, the simulation processes, the translation of intervention to the modelling environment and the data output processes in order for policymakers to use such models appropriately without input from modellers and in a short timeframe.

However, although I feel policymakers should not run the models themselves; they must be an integral part of the modelling process. Policymakers need to be specifying the interventions to be simulated rather than relying on researchers to decide them, particularly since it can be difficult for researchers to keep abreast of the policy agenda. My work with Birmingham Regional Health Authority demonstrated how developing the interventions in partnership with policymakers meant that issues important to them were addressed. This in turn made the results of the modelling more policy relevant. In

addition, since the policy agenda will change over time, and is usually dictated by political priorities rather than research priorities (Walt 1994), policymakers need to be constantly involved, otherwise over time models will not be able to address the new policy agenda which will emerge.

My work also highlighted how it is only by using a model to simulate real interventions, such as the HEA physical activity targets and the risk factor interventions in the Birmingham population which were envisioned by policymakers, that one can fully understand a model's capabilities and limitations, which may not be described fully in the model's documentation. I only became aware of the limitations of the models I used after trying to simulate interventions suggested by policymakers and other researchers.

In the course of my work I realised that those using models should not be overly reliant on policymakers to advise on such areas as the effectiveness of interventions, as with the overly optimistic risk factor interventions modelled in the Birmingham population, since researchers may be the best suited for supplying such information. And so, as well as consulting policymakers, there is a need for a review of the literature concerning what changes would be achievable by the intended interventions to be simulated.

17.5 The Potential Impact of Models on Policy

Public health models use simplified theoretical frameworks which allow the simulation of complex dynamic processes. The construction of these frameworks is dependent on theoretical models that link biological, environmental, social and economic factors to health. I feel that it is necessary for modellers to understand these theoretical frameworks, and how the factors influencing health within these frameworks relate to the health policy agenda, in order to build public health models that can be used as tools for policymaking.

The emphasis of health policy has shifted from the Old Public Health model, which was largely concerned with infectious, toxic and traumatic causes of death, to the New Public Health model, which is influenced by the belief that many of the underlying factors for these diseases could be amenable to prevention through social,

environmental or behavioural change (Lancet 1991). Inequalities, in utero and early life experiences, psychosocial factors, and social capital, are part of the current health policy agenda (Acheson 1998 and DoH 1999). These new areas have implications in terms of the need for aetiological research to explain their biological pathways, epidemiological research to explain their effects on risk, and how policy will address them.

However, even when biological and epidemiological evidence is convincing there are barriers that prevent research evidence informing health policy through a simple, linear and logical process, as described by Walt (Walt 1994 and 1995). These barriers include political factors, where findings conflict with the policy impetus or its ideological basis, conceptual confusion, when research does not provide unambiguous results, differences in risks perception, when there is an imbalance between actual and perceived risk, imbalances in the timeframes, when research takes a long time to produce results and policy demands decisions within a short time scale, and inappropriate communication of research findings to policymakers. Modellers need to be aware that the results of their modelling work may not ultimately inform policy, even if the results are convincing, due to these barriers.

17.6 The Implications for Future Research

The time and effort required to develop a new public health model, or to even convert an existing model to another population can be considerable. Even for an existing model the user must gain an adequate understanding of its methodologies, underlying assumptions, data needs and limitations before being able to run the model, and then to fully interpret its output. These time scales may be problematic for policymakers, not only because the policy agenda could change markedly in the time it takes to develop or convert a model, but also because such work requires a long term commitment from funders. Consequently those commissioning modelling work need to be aware of these issues.

I have argued that it is necessary for model developers to understand theoretical frameworks of health, and how their various determinants of health relate to the health policy agenda, in order to build public health models that can be used as a tool for

policymaking. In addition, I have stated that as new issues appear on the policy agenda, as inequalities, early life course and social capital have; models require the flexibility and the capacity to include these factors into their methodology. However, modellers must be aware that there may be a long time before issues which are already on the research agenda appear on the policy agenda. For example, socio-economic factors had been highlighted in the Black Report (DHHS 1980) in 1980, but have only recently been addressed in *Our Healthier Nation* (DoH 1999), this process was dependent on political factors rather than the weight of knowledge, as described in Chapter 2.

Unfortunately, highly technical models, such as POHEM, which have the flexibility and capacity to evolve with health policy, require investment in time and effort from funders and researchers. The Biomed project and Statistics Canada's experiences have demonstrated how long time periods are required to develop models. But model developers must also be aware that models which are computationally intensive may be difficult to use as a policy tool. For example, some simulations can take days to run, as with the case of POHEM when simulating four million individuals. Eventually the computational burden of modelling will become less of a problem as the power of affordable and readily available computers increases. However, at present this may be seen as a barrier to using particular models as policy tools, and at times it may be more appropriate to use simpler models, such as the smoking cessation model of Lightwood et al (Lightwood 1997), to address policy issues within a shorter time frame.

To be able to bridge the gap between epidemiological research and health policy, public health models need to be used by individuals who understand the modelling, epidemiological and policy environments. Since public health models rely heavily on health data, epidemiological measurement of risk, estimations of the effectiveness of interventions and theoretical frameworks of health, and then the translation of these into a computing environment, I feel that someone with a strong grounding in epidemiology and an understanding of computing would be best suited for the role of developing models. In addition they must be able to liaise with modellers and policymakers, and be able to translate issues from each of these arenas to the other, and so will require good negotiating and presentation skills. However, they need to ensure that the model can address the current policy agenda, since ultimately the output of modelling will be

ignored if it is not relevant to the policy agenda. The most plausible strategy for model development, in my opinion, would be to have a team of individuals, whose skills cover the areas of expertise required, working together, as seen at Statistics Canada. Although each individual within the team needs to be able to effectively communicate their ideas to the others in the team, as well as to policymakers.

Having witnessed the development of two models in two settings, with Prevent developed in an academic environment and POHEM developed in a governmental environment, I feel that future public health models should be developed at a governmental level, for instance by the Department of Health in the UK. The experience of Statistics Canada has show that when modelling is perceived as a key area of policy development there will be a commitment to fund the building of a team with the required expertise to develop models, and over a long time-scale, as well as leading to the development of an institutional methodology for modelling. By this I mean that the institution holds the knowledge of the methodology used rather than individuals, and so when individuals leave the institution knowledge is not lost, and new individuals joining the institution can gain the required knowledge for model development from documentation and from having a group of individuals they can consult. This methodology also benefits those outside the institution who wish to use that institution's models. This is in contrast to the development of Prevent at the Universities of Amsterdam and Rotterdam, where short term funding meant that the model has not continually been developed over time, and where only a few individuals can develop the model, and so without these key individuals no future development of Prevent can take place.

In addition, I feel that the developers of POHEM at Statistics Canada have closer links to policymakers than the developers of Prevent, and so the terms of their modelling work is always dictated by policymakers, whereas much of the work with Prevent at University of Amsterdam has been divorced from policy, reflected in its inability to simulate the targeting of high risk individuals, or shifting population risk factor distributions, which are key policy issues. I still think the input of researchers from academia is vital for the development of public health models; those developing models

need to have closer links with policymakers to ensure that these models can always address the current policy agenda, which will be evolving over time.

There is definitely a role for large complex multi-purpose public health models, such as Prevent and POHEM, that can be used as tools for policy development, but these should be developed at a governmental level and should be able to be used to answer a variety of policy questions. The time and effort required to develop such models are not warranted if they can only be used to answer questions on a single issue relevant at one particular time. In such instances the use of simpler models that are quicker to develop and adapt should be used, such as the smoking cessation model (Lightwood 1997) mentioned earlier, or using the Framingham equation for estimating the cost effectiveness of reducing coronary risk factors in primary care (Field 1995).

17.7 Conclusions

My work has shown that public health models can successfully be used as policy tools, and their use can be regarded as a means for bridging the gap between epidemiological research and health policy. I have shown how these models can be used:

- for estimating the future development of the health of populations,
- to evaluate alternative routes to achieving health goals,
- to demonstrate the effect of targeting health interventions at different sections of a population,
- to investigate the relationship between risk factors and their linked diseases, which may be under debate in the research arena,
- for demonstrating the possible effect of health interventions to health practitioners.

At the same time models allow one to develop a deeper insight into the theoretical frameworks of health, as well as demonstrating the need for the collection of routine health data.

In terms of the requirements for public health models intended for use as policy tools, I think that such models need to fulfil the following criteria:

1. Models should be based on readily available data, or in the absence of such data should use a documented method for deriving these data, since otherwise it will not be possible to transfer the model to other populations.
2. Models should have a multi-factorial risk factor and disease environment, where each risk factor can influence several diseases, and each disease can be influenced by several risk factors, otherwise models will underestimate the effect of risk factor interventions.
3. Models should have the ability to produce output in terms of both morbidity and mortality, since models that exclude morbidity will underestimate the true effect of interventions.
4. Models should include a demographic basis by which population changes within the simulation period can be considered, since the effect of a risk factor intervention in a population will not only be dependent on the prevalence of the risk factor, but also on the prevalence by age group, and that population's age structure, with its associated disease patterns.
5. Models need to be implemented in a flexible and adaptable fashion that allows the inclusion of new risk factors and interventions as they appear on the research and policy agendas, otherwise models will become obsolete if they cannot address changes in the policy agenda over time.

6. Models should have the ability to shift risk factor distributions and to target high risk individuals, since these are key strategies in public health that need to be addressed if the model is to be used for informing policy decisions.
7. Models require a user guide which documents the programme sources code, the methodologies used, the underlying assumptions, the data needs and data derivation, the limitations, the computing requirements and the running of the model. Otherwise it will be difficult, if not impossible, for other modellers to adapt, use, or understand a model.

The validation of such public health models may always be difficult due to the lack of available data to compare their output with, and there will probably never be a “gold standard” for such models. The “face-validity” of the parameters used by the model can be checked to a certain extent, and their methodologies can be verified using other models. This is not an ideal situation, but I feel that one is justified in using unvalidated models as long as one draws attention to the fact that the model is unverified and can only yield results of a hypothetical nature. Such models are probably best used in comparing the effect of various interventions, based on the same data and assumptions, rather than for estimating the effect of individual interventions viewed in isolation. However, if data are available, modellers should always attempt to validate their models by using historical data to simulate current disease patterns (Kotva 1992).

Modellers must understand that modelling will not dictate policy, but will only quantify one step in the policymaking process. My work has shown that barriers other than the lack of evidence may hamper policymaking, and policymakers may only pick out the bits of the research that support the areas that they already see as important, rather than highlighting new areas for the policy. At the same time it is important for modellers not to be divorced from policy. In order to use models as tools for policy, policymakers must be involved in the processes of developing the models and deciding on the interventions to be modelled.

To summarise, the key conclusions from my work are that:

- Public health models can be used as policy tools, although ultimately they may only inform policy, and not drive it, due to other factors which can influence the policy agenda. This was demonstrated by the HEA's dropping of the modelled physical activity targets due to the political sensitivity of the unmet *Health of the Nation* targets at the time, and by Birmingham Region Health Authority's use of only the results from the smoking simulations since smoking was already on their policy agenda.
- Public health models need to be developed and used in conjunction with policymakers, although models need to be developed, adapted and run by researchers who fully understand their workings. This was demonstrated by Prevent's inability to simulate high risk and population risk factor intervention strategies due to its being developed in isolation from policymakers.
- Public health models are complex instruments that require a long term commitment in terms of the funding required to build and retain the modelling expertise of those researchers involved in the development of such models. This is shown by the differences in the development of Prevent and POHEM, with Prevent's lack of development resulting from being dependent on one individual whose research priorities were no longer to work on the model, while POHEM uses methodologies that are consistent across all Statistics Canada's modelling work, and which has been committed to over a long time scale, as well as Statistics Canada investing in the training of a large group of individuals who are able to develop the model.
- Public health models need to be developed by multidisciplinary teams, whose expertise cover the areas of computing, epidemiology and health policy, since an understanding of health data, epidemiological measurement of risk, estimations of the effectiveness of interventions and theoretical frameworks of health, and the translation of these into a computing environment is required. In addition, the members of the team need to be able to communicate their ideas effectively to each other and to policymakers.

- **Public health models may never be validated in terms of a “gold standard”, but they can be used as policy tools as long as one is aware that they are unverified and that they yield results of a hypothetical nature. Although ultimately modellers should always attempt to validate their models by using historical data to simulate current disease patterns, if such data are available.**

Section 5: References

4S Group (1994) Randomised trial of cholesterol lowering in 4444 patients with coronary heart disease: the Scandinavian Simvastatin Survival Study (4S). *Lancet* **344**(8934): 1383-9.

Aalen OO (1991) Modelling the Influence of Risk Factors on Familiar Aggregation of Disease. *Biometrics* **47**: 933-45.

Acherson D [Chairman] (1998) *Independent Inquiry into Inequalities in Health Report*. The Stationary Office, London.

Acheson D (1998) Inequalities in health. Report on inequalities in health did give priority for steps to be tackled [letter]. *British Medical Journal* **317**(7173): 1659.

Ackerman E (1994¹) Simulation of micropopulations in epidemiology: tutorial 1. simulations; an introduction. *International Journal of Bio-Medical Computing* **36**: 229-38.

Ackerman E (1994²) Simulation of micropopulations in epidemiology: tutorial 2. Analytic forms of event probabilities. A series of tutorials illustrated by coronary heart disease models. *International Journal of Bio-Medical Computing* **37**(2): 139-49.

Ackerman E (1994³) Simulation of micropopulations in epidemiology: tutorial. 3. Simulation model evaluation methods. A series of tutorials illustrated by coronary heart disease models. *International Journal of Bio-Medical Computing* **37**(3): 195-204.

Ackerman E (1994⁴) Simulation of micropopulations in epidemiology: tutorial. 4. Evaluations of simulation models. A series of tutorials illustrated by coronary heart disease. *International Journal of Bio-Medical Computing* **39**(2): 219-29.

Adams S and Hagar S (1991) What the government should do. *British Medical Journal* **202**:1120-3.

Anderson KM, Odell PM, Wilson PWF and Kannel WB (1990) Cardiovascular disease risk profiles. *American Heart Journal* **121**: 293-8.

Ashley JSA, Cole SK, and Kilbane MPJ (1997) Health information resources in the United Kingdom. *Oxford Textbook of Public Health – Third Edition*. Detels R, Holland WW, McEwen J and Omenn GS (Editors). Oxford University Press, Oxford.

Ashton J (1991) The health of the nation [editorial]. *British Medical Journal* **302**(6790): 1413-4.

Ashton J (1999) Inequalities in health. Independent inquiry gives detailed recommendations [letter]. *British Medical Journal* **318**(7183): 601.

Assmann G and Schulte H (1990) Modelling the Helsinki Heart Study by means of risk equations obtained from the PROCAM Study and the Framingham Heart Study. *Drugs* **40** (Suppl 1): 13-8.

Audit Commission (1995) *Dear to Our Hears? Commissioning Services for the Treatment and Prevention of Coronary Heart Disease*. HMSO, London.

Baan CA, Mooy JM and Gunning-Schepers LJ (1999) Estimates of several anti-tobacco policies in four European countries. *Public Health Models – Tools For Health Policy Making At National And European Level*. Final Project Report to the E.U.

Bamford J, Sandercock P, Dennis M, Warlow C, Jones L, McPherson K, Vessy M, Fowler G, Molyneux A, Hughes T, Burn J and Wade D (1988) A prospective study of acute cerebrovascular disease in the community: the Oxford Community stroke Project 1981-86 – 1. Methodology, demography and incident cases of first-ever stroke. *Journal of Neurology, Neurosurgery and Psychiatry* **51**: 1373-1380.

Barendregt JJ and Gunning-Schepers LJ (1990) *PREVENT version 2.1 User Manual*.

Barendregt JJ (1994). From Prevent to NIMPH and back: Some methodologic issues in public health modelling. Paper presented to the European Public Health Association Conference, December, Copenhagen. *Unpublished*.

Barendregt JJ, Bonneux L and van der Mass PJ (1997) The health care costs of smoking. *New England Journal of Medicine* 337:1052-7.

Barker DJ and Osmond C (1986) Infant mortality, childhood nutrition, and ischaemic heart disease in England and Wales. *Lancet* 1(8489): 1077-81.

Bennett N, Dodd T, Flatley J, Freeth S and Bolling K (1995) *OPCS Health Survey for England 1993*. HMSO, London.

Ben-Shlomo Y, White IR and Marmot M (1996) Does the variation in the socioeconomic characteristics of an area affect mortality? *British Medical Journal* 312(7037): 1013-4.

Bensley DC, Watson PS and Morrison GW (1995). Pathways of Coronary Care - A Computer Simulation Model of the Potential for Health Gain. *IMA Journal of Mathematics and Applied Medical Biology* 12(3-4): 315-28.

Berlin JA, Colditz GA (1990). A meta-analysis of physical activity in the prevention of coronary heart disease. *American Journal of Epidemiology* 132: 612-27.

Berridge V (2000) Historical and policy approaches to the evaluation of health promotion. *Evaluating Health Promotion: Practice and Methods*. Thorogood M and Coombes Y (Editors) Oxford University Press, Oxford.

Biomed II (1999) *Public Health Models – Tools For Health Policy Making At National And European Level*. Final Project Report to the E.U.

Birch S (1999) The 39 steps: the mystery of health inequalities in the UK [editorial]. *Health Economics* 8(4): 301-8.

Birt C (1996) United Kingdom Country Report. *International Handbook of Public Health*. Hurrelmann K and Laaser U (Editors). Greenwood Press, Westport, Connecticut.

Black D, Morris JN, Smith C and Townsend P (1999) Better benefits for health: plan to implement the central recommendation of the Acheson report. *British Medical Journal* 318(7185): 724-7.

Blair SN and Connelly JC (1996) How Much Physical Activity Should We Do? The Case for Moderate Amounts and Intensities of Physical Activity. *Research Quarterly for Exercise and Sport* 67;2:192-205.

Blower S and Medley G (1992) Epidemiology, HIV and drugs: mathematical models and data. *British Journal of Addiction* 87: 371-9.

BMJ (2000) *Clinical Evidence: a compendium of the best available evidence for effective health care*. BMJ, London.

Bonneux L and Barendregt (1992) Towards a Comprehensive Health Policy Model. *Models of Noncommunicable Diseases - Health Status and Health Service Requirements*. Morgenstern W, Chigan E, Prokhorskas R, Rusnak M and Schettler G (Editors). Springer-Verlag, Berlin.

Bonneux L, Barendregt JJ, Koopmanschap MA, van Oortmarssen GJ, Looman CWN, Bonsel GJ and van der Mass PJ. Colorectal Cancer Morbidity in the Netherlands. *Unpublished*.

Bonneux L, Barendregt JJ, Meeter K, Bonsel GJ and van der Maas PJ (1994) Estimating Clinical Morbidity Due to Ischemic Heart Disease and Congestive Heart Failure: The Future Rise of Heart Failure. *American Journal of Public Health* **84**: 20-8.

Bonneux L, Barendregt JJ, van Oortmarssen GJ, Looman CWN, Bonsel GJ and van der Mass PJ. Model Based Estimates of Current and Future Cancer Morbidity in the Netherlands. *Unpublished*.

Bonneux L, Barendregt JJ and van der Mass PJ (1999) The New Old Epidemic of Coronary Heart Disease. *American Journal of Public Health* **89**:379-382.

Brunner E, White I, Thorogood M, Bristow A, Curle D and Marmot M (1997) Can dietary interventions change diet and cardiovascular risk factors? A meta-analysis of randomized controlled trials. *American Journal Public Health* **87**(9): 1415-22.

Budde T, Haude M, Hopp HW, Kerber S, Caspari G, Fassbender G, Fingerhut M, Novopashenny I, Breithardt G, Erbel R, Erdmann E and Wischnewsky MB (1997) A prognostic computer model to predict individual outcome in interventional cardiology. The INTERVENT Project. *European Heart Journal* **18**(10): 1611-9.

Canada (1974) *A New Perspective on the Health of Canadians (Lalonde Report)*. Department of National Health and Welfare, Ottawa.

Capewell S, Morrison CE and McMurray JJ (1999¹) Contribution of modern cardiovascular treatment and risk factor changes to the decline in coronary heart disease mortality in Scotland between 1975 and 1994. *Heart* **81**(4): 380-6.

Capewell S, Pell JP, Morrison C and McMurray J (1999²) Increasing the impact of cardiological treatments. How best to reduce. *European Heart Journal* **20**(19): 1386-92.

Catford JC (1991) Health targets [editorial]. *British Medical Journal* **302**(6783): 980-1.

Chambless LE, Dobson AJ, Patterson CC and Raines B (1990) On the use of a logistic risk score in predicting risk of coronary heart disease. *Statistics In Medicine* 9: 385-96.

Chang HGH, Lininger LL, Doyle JT, MacCubbin PA and Rothenberg RB (1990) Application of the Cox Model as a predictor of relative risk of coronary heart disease in the Albany Study. *Statistics In Medicine* 9: 287-92.

Charlton J and Murphy M (1997) Monitoring health – data sources and methods. *The Health of adult Britain 1841-1994 Volume 1*. Charlton J and Murphy M (Editors). The Stationary Office, UK.

Chigan EN (1992) Introduction. *Models of Noncommunicable Diseases - Health Status and Health Service Requirements*. Morgenstern W, Chigan E, Prokhorskas R, Rusnak M and Schettler G (Editors). Springer-Verlag, Berlin.

Clayton D and Hills M (1993) *Statistical Models in Epidemiology*. Oxford University Press, Oxford.

Colhoun H, Prescott-Clarke P, Dong W et al (1996) *Health Survey for England 1994*. HMSO, London.

Collins R, Peto R, MacMahon S, Hebert P, Fiebach NH, Eberlein KA, Godwin J, Qizilbash N, Taylor JO and Hennekens CH (1990) Blood pressure, stroke, and coronary heart disease. Part 2, Short-term reductions in blood pressure: overview of randomised drug trials in their epidemiological context. *Lancet* 335(8693): 827-38.

Coombes Y (2000¹) Combining quantitative and qualitative approaches to evaluation. *Evaluating Health Promotion: Practice and Methods*. Thorogood M and Coombes Y (Editors) Oxford University Press, Oxford.

Coombes Y and Thorogood M (2000²) Introduction. *Evaluating Health Promotion: Practice and Methods*. Thorogood M and Coombes Y (Editors) Oxford University Press, Oxford.

Corrao G, Bagnardi V, Zambon A and Arico S (1999) Exploring the dose-response relationship between alcohol consumption and the risk of several alcohol-related conditions: a meta-analysis. *Addiction* **94**(10): 1551-1573.

Coulter A, Brown S and Daniels A (1989) Computer held chronic disease registers in general practice: a validation study. *Journal of Epidemiology and Community Health* **43**(1): 25-8.

Criqui MH, Barrett-Conner E, Holdbrook MJ, Austin M and Turner JD (1980) Clustering of Cardiovascular Disease Risk Factors. *Preventive Medicine* **9**: 525-33.

Davey-Smith G and Morris J (1994) Increasing inequalities in the health of the nation [editorial]. *British Medical Journal* **309**(6967): 1453-4.

Davey-Smith G, Hart C, Hole D, MacKinnon P, Gillis C, Watt G, Blane D and Hawthorne V (1998¹) Education and occupational social class: which is the more important indicator of mortality risk? *Journal of Epidemiology and Community Health* **52**(3): 153-60.

Davey-Smith G, Morris JN and Shaw M (1998²) The independent inquiry into inequalities in health is welcome, but its recommendations are too cautious and vague [editorial]. *British Medical Journal* **317**(7171): 1465-6.

Dawber TR and Kannel WB (1966) The Framingham study. An epidemiological approach to coronary heart disease. *Circulation* **34**(4): 553-5.

Dean M (1992) Health, but not for all [news]. *Lancet* **340**(8812): 166-7.

Department of Health (1988) *Public health in England (the Acheson report)*. HMSO, London.

Department of Health (1995) *Hospital Episode Statistics – Volume 1 Finished consultant episodes by diagnosis, operation and specialty, England: Financial year 1993-94*. DoH, London.

Department of Health (1996) *Strategy Statement On Physical Activity*. HMSO, London.

Department of Health (1999) *Saving Lives: Our Healthier Nation*. The Stationery Office, London.

DHHS (1980) *Inequalities in health. Report of a research group. (Black report)*. DHHS, London.

Durrington PN, Prais H, Bhatnagar D, France M, Crowley V, Khan J and Morgan J (1999) Indications for cholesterol-lowering medication: comparison of risk-assessment methods. *The Lancet* **353**: 278-81.

Elkan R and Robinson J (1998) The use of targets to improve the performance of health care providers: a discussion of government policy. *British Journal of General Practice* **48**(433): 1515-8.

Evans RG and Stoddart GL (1990) *Producing health, consuming health care*. Paper prepared for CHEPA conference Producing Health: Implications of Social Policy. May 24-25 1990. Niagara-on-the-Lake, Ontario.

Feinleib M, Kannel WB, Garrison RJ, McNamara PM and Castelli WP (1975) The Framingham Offspring Study. Design and preliminary data. *Preventive Medicine* **4**(4): 518-25.

Fentem PH, Collins MF, Tuxworth, Walker A, Hoinville E, Cooke C, Harries UJ and Rayson M (1994) *Allied Dunbar National Fitness Survey – Technical Report*. Sports Council and Health Education Authority.

Field K, Thorogood M, Silagy C, Normand C, O'Neill C and Muir J (1995) Strategies for reducing coronary risk factors in primary care: which is most cost effective? *British Medical Journal* **310**(6987): 1109-12.

Foulds J (1996) Strategies for smoking cessation. *British Medical Bulletin* **52**(1): 157-73.

Fraser P, Fleming D, Murphy M, Charlton J, Gill L and Goldacre M (1997) Morbidity statistics from health service utilisation. *The Health of adult Britain 1841-1994 Volume 1*. Charlton J and Murphy M (Editors). The Stationery Office, London.

Fulop N and Hunter DJ (1999) Saving lives or sustaining the public's health? [editorial]. *British Medical Journal* **319**(7203): 139-40.

Gabbay J (1992) The health of the nation [editorial]. *British Medical Journal* **305**(6846): 129-30.

Gabbay J (1998) Our healthier nation [editorial]. *British Medical Journal* **316**(7130): 487-8.

Glantz SA (1993) Changes in cigarette consumption, prices and tobacco industry revenues associated with California's Proposition 99. *Tobacco Control* **2**: 311-314.

Glick H, Heyse JF, Thompson D, Epstein RS, Smith ME and Oster G (1992) A model for evaluating the cost-effectiveness of cholesterol-lowering treatment. *International Journal of Technology Assessment in Health Care* **8**(4): 719-34.

Goldman L, Weinstein MC and Williams LW (1989) Relative Impact of Targeted Versus Populationwide Cholesterol Interventions on the Incidence of Coronary Heart Disease. *Circulation* **80**: 254-60.

Goldman L, Weinstein MC, Goldman PA and Williams LW (1991) Cost-effectiveness of HMG-CoA Reductase Inhibition for Primary and Secondary Prevention of Coronary Heart Disease. *Journal of the American Medical Association* **265**: 1145-51.

Gordon D, Shaw M, Dorling D and Davey-Smith G (editors) (1999) *Inequalities in health: The evidence*. The Policy Press, Bristol.

Greenberg M (1992) Impediments to basing government policies on science in the United States. *Social Science and Medicine* **35**: 531-40.

Grover SA, Abrahamowicz M, Joseph L, Brewer C, Coupal L and Suissa S (1992) The Benefit of Treating Hyperlipidemia to Prevent Coronary Heart Disease. *Journal of the American Medical Association* **267**: 816-22.

Grover SA, Coupal L and Hu XP (1995) Identifying adults at increased risk of coronary disease. How well do the current cholesterol guidelines work? *Journal of the American Medical Association* **274**(10): 801-6.

Grover SA (1999) Gambling with cardiovascular risk: picking the winners and the losers [comment] *Lancet* **353**(9149): 254-5.

Grundy SM, Balady GJ, Criqui MH, et al (1998) Primary prevention of coronary heart disease: guidance from Framingham. A statement for healthcare professionals from the AHA taskforce on risk reduction. *Circulation* **97**: 1876-87.

Gunning-Schepers LJ (1989) The Health Benefits of Prevention, A Simulation Approach. *Health Policy* **12**: 1-256.

Gunning-Schepers LJ and Barendregt JJ (1992¹) Timeless Epidemiology or History Cannot Be Ignored. *Journal of Clinical Epidemiology* **45**: 365-72.

Gunning-Schepers LJ, Barendregt JJM and van der Mass PJ (1992²) PREVENT, a Model to Estimate the Health Benefits of Prevention. *Models of Noncommunicable Diseases - Health Status and Health Service Requirements*. Morgenstern W, Chigan E, Prokhorskas R, Rusnak M and Schettler G (Editors). Springer-Verlag, Berlin.

Gunning-Schepers, L. J (1994) Prevent and the projected burden of CHD in the Netherlands: An illustration of the serumcholesterol dilemma. *Archives of Public Health* **52**: 5-20.

Gunning-Schepers LJ (1995) Central issues in future research and policy for chronic diseases. *European Journal of Public Health* **5**: 3-7.

Gunning-Schepers LJ (1999) Models: instruments for evidence based policy. *Journal of Epidemiology and Community Health* **53**: 263.

Habbema JDF, van Oortmarssen GJ, Lubbe JTN and van der Maas PJ (1984) The MISCAN simulation program for the evaluation of screening for disease. *Computer Methods and Programs in Biomedicine* **20**: 79-93.

Haskell WL (1995) *Physical Activity, Lifestyle and Health in America (abstract)*. NIH Consensus Development Conference on Physical Activity & Cardiovascular Health, Bethesda, Maryland, USA.

Hatziandreu EI, Koplan JP, Weinstein MC, Caspersen CJ and Warner KE (1988) A Cost- Effective Analysis of Exercise as a Health Promotion Activity. *American Journal of Public Health* **78**: 1417-21.

Haq IU, Ramsay LE, Yeo WW, Jackson PR and Wallis EJ (1999) Is the Framingham risk function valid for northern European populations? A comparison of methods for estimating absolute coronary risk in high risk men. *Heart* **81**(1): 40-6.

Health Education Authority (1991). *The Health Education Authority response to The Health of The Nation*. HEA, London.

Health Education Authority (1994). *Moving on - International perspectives on promoting physical activity*. HEA, London.

Heller T, Bailey L, Gott M, Howes M (Editors) (1987) *Coronary Heart Disease: Reducing the Risk - A Reader*. Open University Set Book, John Wiley & Sons, Chichester.

Hingorani AD and Vallance P (1999) A simple computer program for guiding management of cardiovascular risk factors and prescribing. *British Medical Journal* **318**: 101-5.

HMSO (1992) *The Health of the Nation*. London: HMSO.

Horton R (1998) Our healthier nation, possibly. *Lancet* **351**(9101): 463.

Iannelli M, Loro R, Milner F, Pugliese A and Rabbio (1992) An Aids Model With Distributed Incubation And Variable Infectiousness: Applications to IV Drug Users In Latium, Italy. *European Journal of Epidemiology* **8**: 585-93.

Kahn JG (1996) The Cost-Effectiveness of HIV prevention Targeting: How Much More Bang for the Buck? *American Journal of Public Health* **86**: 1709-12.

Kannel WB, Feinleib M, McNamara PM, Garrison RJ and Castelli WP (1979) An investigation of coronary heart disease in families. The Framingham offspring. *American Journal of Epidemiology* **110**(3): 281-90.

Kannel WB, Belanger A, D'Agostino R and Israel I (1986) Physical activity and physical demand on the job and risk of cardiovascular disease and death: the Framingham study. *American Heart Journal* **112**: 820-5.

Kannel WB (1988) Contributions of the Framingham Study to the conquest of coronary artery disease. *American Journal of Cardiology* **62**(16): 1109-12.

Kawachi I, Kennedy BP, Lochner K and Prothrow-Stith D (1997) Social capital, income inequality, and mortality. *American Journal of Public Health* **87**(9): 1491-8.

Klatsky AL, Friedman GD and Siegelaub AB (1981) Alcohol and Mortality. A Ten-Year Kaiser-Permanente Experience. *Annals of Internal Medicine* **95**: 139-45.

Klepp KI and Forster JL (1985) The Norwegian Nutrition and Food Policy: An Integrated Policy Approach to a Public Health Problem. *Journal of Public Health Policy* **6**(4): 447-63.

Kotva M (1992) Some Conceptual Problems in the Simulation of Epidemiological Processes. *Models of Noncommunicable Diseases - Health Status and Health Service Requirements*. Morgenstern W, Chigan E, Prokhorskas R, Rusnak M and Schettler G (Editors). Springer-Verlag, Berlin.

Lagergren M (1995) What is the Role and Contribution of Models to Management and Research in the Health Service. Report to the Swedish Ministry of Health and Social Affairs. *Unpublished*.

Lalonde M (1977) "Beyond a New Perspective" – *The Fourth Annual Matthew B. Rosenhaus Lecture*. American Public Health Association, 104th Annual Meeting, Florida.

Lancet Editorial (1991) What's new in public health? *Lancet* **337**: 1381-83.

Langlands A (1996) Promoting the Health of the Nation. *British Journal of Hospital Medicine* 56(4): 171-2.

Last JM (1987) *Public health and human ecology*. Prentice-Hall, Sydney.

Laurier D, Nguyen PC, Cazelles B and Segond P (1994) Estimation of CHD risk in a French working population using a modified Framingham model. The PCV-METRA Group. *Journal of Clinical Epidemiology* 47(12): 1353-64.

Leaverton PE, Sorlie PD, Kleinman JC, Dannenberg AL, Ingster-Moore L, Kannel WB and Cornoni-Huntley JC (1987) Representativeness of the Framingham risk model for coronary heart disease mortality: a comparison with a national cohort study. *Journal of Chronic Disease* 40(8): 775-84.

Levine S and Lilienfeld AM (1987) *Epidemiology and Health Policy*. New York, Tavistock.

Lewando-Hundt G and Al-Zaroo S (2000) Evaluating the dissemination of health promotion research. *Evaluating Health Promotion: Practice and Methods*. Thorogood M and Coombes Y (Editors) Oxford University Press, Oxford.

Liao Y, McGee DL, Cooper RS and Sutkowski MB (1999) How generalizable are coronary risk prediction models? Comparison of Framingham and two national cohorts. *American Heart Journal* 137(5): 837-45.

Lightwood JM and Glantz SA (1997) Short-term economic and health benefits of smoking cessation: myocardial infarction and stroke. *Circulation* 96(4): 1089-96.

Lomas J (1998) Social capital and health: implications for public health and epidemiology. *Social Science & Medicine* 47(9): 1181-8.

Manson JE, Hu FB, Rich-Edwards JW, Colditz GA, Stampfer MJ, Willett WC, Speizer FE, Hennekens CH (1999) A prospective study of walking as compared with vigorous exercise in the prevention of coronary heart disease in women. *New England Journal of Medicine* **341**: 650-8.

Manton KG and Stallard E (1988) *Chronic Disease Modelling*. Charles Griffen & Company Ltd., London.

Marmot MG, Rose G, Shipley MJ and Thomas BJ (1981) Alcohol and mortality: a U-shaped curve. *Lancet* **1**(8220 Pt 1): 580-3.

Marmot M (1989) Socioeconomic determinants of CHD mortality. *International Journal of Epidemiology* **18**(3 Suppl 1): S196-202.

Marmot M and Elliot P (Editors) (1992) *Coronary Heart Disease Epidemiology - From Aetiology to Public Health*. Oxford University Press, Oxford.

Marmot M (1995) A not-so-sensible drinks policy. *Lancet* **346**(8991-8992): 1643-4.

Marmot M, Ryff CD, Bumpass LL, Shipley M and Marks NF (1997) Social inequalities in health: next questions and converging evidence. *Social Science & Medicine* **44**(6): 901-10.

Maxwell RJ (1998) Our healthier nation: alpha for presentation, beta minus for deliverability [editorial]. *Journal of Epidemiology and Community Health* **52**(8): 474-5.

McCormick A, Fleming D and Charlton J (1995) *Morbidity Statistics from General Practice - Fourth national study 1991-1992*. Series MB5 no.3. HMSO, London.

McKee M and Steyger E (1997) When can the European Union restrict trade on the grounds of public health. *Journal of Public Health Medicine* **19**: 85-86.

McPherson K (1992) Modelling Latent Effects in any association between Oral Contraceptives and Breast Cancer. *Models of Noncommunicable Diseases - Health Status and Health Service Requirements*. Morgenstern W, Chigan E, Prokhorskas R, Rusnak M and Schettler G (Editors). Springer-Verlag, Berlin.

Michalski AI and Yashin AI (1992) A Probabilistic Model for Cancer Prevalence Estimation on Mortality Data. *Models of Noncommunicable Diseases - Health Status and Health Service Requirements*. Morgenstern W, Chigan E, Prokhorskas R, Rusnak M and Schettler G (Editors). Springer-Verlag, Berlin.

Mooney G and Healey A (1991) The Health of the Nation: responses. Strategy full of good intentions. *British Medical Journal* **303**(6810): 1119-20.

Morgenstern W, Chigan E, Prokhorskas R, Rusnak M and Schettler G (Editors) (1992) *Models of Noncommunicable Diseases - Health Status and Health Service Requirements*. Springer-Verlag, Berlin.

Morris, J.N., D.G. Clayton, M.G. Everitt, A.M. Semmence and E.H. Burgess (1990) Exercise in leisure time: coronary attack and death rates. *British Heart Journal* **63**: 325-34.

Morris JN (1996) *Exercise Versus Heart Attack: Questioning the Consensus*. Research Quarterly for Exercise and Sport **67**;2: 216-20.

Mui SL (1999) Projecting coronary heart disease incidence and cost in Australia: results from the incidence module of the Cardiovascular Disease Policy Model. *Australian and New Zealand Journal of Public Health* **23**(1): 11-9.

Murray CJ and Lopez AD (1997¹) Mortality by cause for eight regions of the world: Global Burden of Disease Study. *Lancet* **349**(9061): 1269-76.

Murray CJ and Lopez AD (1997²) Regional patterns of disability-free life expectancy and disability-adjusted life expectancy: global Burden of Disease. *Lancet* 349(9062): 1347-52.

Murray CJ and Lopez AD (1997³) Global mortality, disability, and the contribution of risk factors: Global Burden of Disease Study. *Lancet* 349(9063): 1436-42.

Murray CJ and Lopez AD (1997⁴) Alternative projections of mortality and disability by cause 1990-2020: Global Burden of Disease Study. *Lancet* 349(9064): 1498-504.

Naidoo B, Thorogood M, McPherson K, Gunning-Schepers LJ (1997) Modelling the effects of increased physical activity on coronary heart disease in England and Wales. *Journal of Epidemiology and Community Health* 51: 144-150.

Niessen LW, Barendregt JJ, Bonneux L and Koudstaal PJ (1993) Stroke trends in an aging population. The Technology Assessment Methods Project Team. *Stroke* 24(7): 931-9.

Norman P and Fitter M (1991) The potential and limitations of opportunistic screening: data from a computer simulation of a general practice screening programme. *British Journal of General Practice* 41:188-91.

Nutbeam D (1998) Evaluating health promotion – progress, problems and solutions. *Health Promotion International* 13(1): 27-44.

OPCS (1995¹) *1991 Census – Topic Reports for Health Areas, Great Britain Volume 1 of 2*. HMSO, London.

OPCS (1995²) *Population Trends* 81. HMSO, London.

OPCS (1995³) *1993 Mortality Statistics, cause, England & Wales*. Series DH2 no.20. The Stationery Office, London.

ONS (1997) *1991 Cancer statistics registrations*. Series MB1 no.24. HMSO, London.

ONS (1998) *Living in Britain – Results from the 1996 General Household Survey*. The Stationery Office, London.

Paffenbarger RS Jr, Hyde RT, Wing AL and Steinmetz CH (1984) A natural history of athleticism and cardiovascular health. *Journal of the American Medical Association* **252**(4): 491-5.

Peto R, Lopez AD, Boreham J, Thun M and Heath C, Jr (1992) Mortality from tobacco in developed countries: indirect estimation from national vital statistics. *Lancet* **339**(8804): 1268-78.

Powell KE, Thompson PD, Caspersen CJ, Kendrick JS (1987). Physical activity and the incidence of coronary heart disease. *Annual Review of Public Health* **8**: 253-87.

Powell KE and Blair SN (1994) The public health burdens of sedentary living habits: theoretical but realistic estimates. *Medicine & Science in Sports & Exercise* **26**;7:851-6.

Prentice AM and Jebb SA (1995) Obesity in Britain: gluttony or sloth? *British Medical Journal* **311**: 437-9.

Putnam RD (1995) Bowling alone. America's declining social capital. *Journal of Democracy* **6**: 65-78.

Randall T, Muir J and Mant D (1992) Choosing the preventive workload in general practice: practical application of the Coronary Prevention Group guidelines and Dundee coronary risk-disk. *British Medical Journal* **305**: 227-32.

Report (1996) *Alcohol, Cardiovascular Disease, Sensible Limits and Population Health*. Report of a Working Group to The Royal College of Physicians, The Royal College of Psychiatrists and The Royal College of General Practitioners.

RIVM (1994) *Public Health Status and Forecasts: The health status of the Dutch population over the period 1950-2010*. Ruwaard D, Kramers PGN, van den Berg Jeths A and Achterberg PW editors. RIVM. Bilthoven.

Rose G (1992). *The Strategy of Preventive Medicine*. Oxford University Press, Oxford.

Royston G (1999) Commentary: trials versus models in appraising screening programmes [comment]. *British Medical Journal* **318**(7180): 360-1.

Rusnak M, Scherbov and Cider B (1992) Mortality and morbidity projections: lung cancer. *Models of Noncommunicable Diseases - Health Status and Health Service Requirements*. Morgenstern W, Chigan E, Prokhorskas R, Rusnak M and Schettler G (Editors). Springer-Verlag, Berlin.

Selmer R (1990) A comparison of Poisson regression models fitted to multiway summary tables and Cox's survival model using data from blood pressure screening in the city of Bergen, Norway. *Statistics In Medicine* **9**: 1157-65.

Shaper AG, Pocock SJ, Phillips AN and Walker M (1987) A scoring system to identify men at high risk of heart attack. *Health Trends* **19**: 37-9.

Shaper AJ, Wannamethee G (1991). Physical activity and ischaemic heart disease in middle-aged British men. *British Heart Journal* **66**: 384-94.

Shaw C (1994) Accuracy and uncertainty of national population projections for the United Kingdom. *Population Trends* **77**: 24-32.

Shepherd J, Cobbe SM, Ford I, Isles CG, Lorimer AR, MacFarlane PW, McKillop JH and Packard CJ (1995) Prevention of coronary heart disease with pravastatin in men with hypercholesterolemia. West of Scotland Coronary Prevention Study Group. *New England Journal of Medicine* **333**(20): 1301-7.

Silagy CA, Fowler GH (1994). Systematically reviewing the effectiveness of pharmacological and non-pharmacological smoking cessation methods. *Journal of Smoking-Related Disease* **5** (Suppl. 1): 295-303.

Smith SJ, Muir KR, Wolstenholme JL, Thornhill KG, Zamorski A, Tolley K, Logan RF and Chilvers CE (1997) Continued inadequacies in data sources for the evaluation of cancer services. *British Journal of Cancer* **75**(1): 131-3.

Speller V, Learmonth A, and Harrison D (1997) The search for evidence of effective health promotion. *British Medical Journal* **315**(7104): 361-3.

Sports Council and Health Education Authority (1992). *Allied Dunbar National Fitness Survey*. London: Sports Council.

Statistics Canada (1998). *Modgen Development Language Version 3.6 – User's Guide*. Statistics Canada.

Stokols D (1996) Translating Social Ecological Theory into Guidelines for Community Health Promotion. *American Journal of Health Promotion* **10**(4): 282-98.

Subcommittee of WHO\ISM Mild Hypertension Liaison Committee (1993). Summary of 1993 World Health Organisation-International Society of Hypertension guidelines for the management of mild hypertension. *British Medical Journal* **207**: 1541-6.

Swerdlow AJ, Douglas AJ, Vaughan Hudson G and Vaughan Hudson B (1993) Completeness of cancer registration in England and Wales: an assessment based on 2,145 patients with Hodgkin's disease independently registered by the British National Lymphoma Investigation. *British Journal of Cancer* 67: 326-329.

Taket AR (1992) Resource Allocation Models and Health Service Systems: an Exploration. *Models of Noncommunicable Diseases - Health Status and Health Service Requirements*. Morgenstern W, Chigan E, Prokhorskas R, Rusnak M and Schettler G (Editors). Springer-Verlag, Berlin.

TAM Research Group (1992) *Modelling of Chronic Disease - Progress Report on Methods, Projections and Cost. With Applications in Breast Cancer and Ischaemic Heart Disease*. Erasmus University, Rotterdam.

Thorsen RD, Jacobs DR, Grim Jr. RH, Keys A, Taylor H and Blackburn H (1979) Preventive Cardiology in Practice: A Device for Risk Estimation and Counselling in Coronary Disease. *Preventive Medicine* 8: 548-56.

Tosteson AN, Weinstein MC, Williams LW and Goldman L (1990) Long-Term Impact of Smoking Cessation on the Incidence of Coronary Heart Disease. *American Journal of Public Health* 80: 1481-6.

Troop P and Green S (1997) The Health of the Nation 4 years on: what have we done, what must we do? *British Journal of Hospital Medicine* 57;3:81-2, 99-100.

Tsevat J, Weinstein MC, Williams LW, Tosteson ANA and Goldman L (1991) Expected Gains in Life Expectancy From Various Coronary Heart Disease Risk Factor Modifications. *Circulation* 83: 1194-1201.

TSO (1996) *Health Survey for England 1998*. TSO, London.

Tunstall-Pedoe H (1991) The Dundee coronary risk-disk for management of change in risk factors. *British Medical Journal* **303**: 744-7.

Tunstall-Pedoe H, Morrison C, Woodward M, Fitzpatrick B and Watt G (1996) Sex differences in myocardial infarction and coronary deaths in the Scottish MONICA population of Glasgow 1985 to 1991. Presentation, diagnosis, treatment, and 28-day case fatality of 3991 events in men and 1551 events in women. *Circulation* **93**(11): 1981-92.

Tunstall-Pedoe H, Kuulasmaa K, Mahonen M, Tolonen H, Ruokokoski E and Amouyel P (1999) Contribution of trends in survival and coronary-event rates to changes in coronary heart disease mortality: 10-year results from 37 WHO MONICA project populations. Monitoring trends and determinants in cardiovascular disease. *Lancet* **353**(9164): 1547-57.

US Department of Health And Human Services (1996). *Physical Activity and Health: A Report of the Surgeon General*. Atlanta, GA.

van Ameijden EJC, van den Hoek JAR and Coutinho RA (1996) Large Declines in Sexual Risk Behavior with Noncommercial Partners among Heterosexual Injection Drug Users in Amsterdam, 1989-1995. *American Journal of Epidemiology* **144**: 772-81.

van de Mheen and Gunning-Schepers LJ (1996) Differences between studies in reporting relative risks associated with smoking: an overview. *Public Health Reports* **111**:420-26.

van de Mheen and Gunning-Schepers LJ (1997) Assuming independence of risk factor prevalences in simulation models like PREVENT. When are outcomes seriously biased? *European Journal of Public Health* **7**:216-20.

van Haastrecht HJA, van den Hoek AJAR and Coutinho RA (1994) High mortality among HIV-infected injecting drug users without AIDS diagnosis: implications for HIV infection epidemic modellers? *AIDS* 8: 363-66.

van Hout BA and Habbema JDF (1992) Micro Simulation of Costs and Effects: the Case of Heart Transplantation. *Models of Noncommunicable Diseases - Health Status and Health Service Requirements*. Morgenstern W, Chigan E, Prokhorskas R, Rusnak M and Schettler G (Editors). Springer-Verlag, Berlin.

Vilnius D and Dandoy S (1990) A Priority Rating System for Public Health Programs. *Public Health Reports* 105: 463-70.

Walt G (1994) *Health Policy: An Introduction to Process and Power*. London, Zed Books.

Walt G (1995) *Public Health Science and Health Policy*. Scientific Foundations for a Public Health Policy in Europe = Wissenschaftliche Grundlagen für eine europäische Public Health Politik. Laaser U, de Leeuw E and Stock C editors. Juventa Verlag, Weinheim and München.

Weinstein MC and Stason WB (1985) Cost-Effectiveness of Interventions to Prevent or Treat Coronary Heart Disease. *Annual Review of Public Health* 6: 41-63.

Weinstein MC, Coxson PG, Williams LW, Pass TM, Stason WB and Goldman L (1987) Forecasting Coronary Heart Disease Incidence, Mortality, and Cost: The Coronary Heart Disease Policy Model. *American Journal of Public Health* 77: 1417-26.

White A, Nicolaas, Foster K, Browne F and Carey S (1993) *OPCS Health Survey for England 1991*. HMSO, London.

WHO (1978) *Alma Ata 1978. Primary health care*. WHO, Geneva.

WHO (1979) *Formulating strategies for health for all by the year 2000*. WHO, Geneva.

WHO (1981) *Global strategy for health for all by the year 2000*. WHO, Geneva.

WHO Expert Committee (1982) *Prevention of coronary heart disease*. WHO Technical Report Series 678, WHO, Geneva.

WHO, scientific group (1983) *Primary prevention of essential hypertension*. WHO, Geneva.

WHO (1985) *Targets for Health for All 2000*. WHO Regional Office for Europe, Copenhagen.

WHO (1986) *The Ottawa charter: principles for health promotion*. WHO Regional Office for Europe, Copenhagen.

WHO (1993) *Health for all targets. The health policy for Europe* [Revised edition]. WHO Regional Office for Europe, Copenhagen.

WHO/OMS (1997) *The WHO MONICA Project*. URL: <http://www.ktl.fi/monica>.

Williams A (1999) Commentary on the Acheson report [editorial]. *Health Economics* 8(4): 297-9.

Wilson PWF, D'Agostino RB, Levy D, Belanger AM, Silbershatz H and Kannel WB (1998) Prediction of coronary heart disease using risk factor categories. *Circulation* 97:1837-47.

Winkelstein W Jr and Marmot M (1981) Primary prevention of ischemic heart disease: evaluation of community interventions. *Annual Review of Public Health* 2: 253-76.

Wolfson MC (1991) POHEM - A New Approach to the Estimation of Health Status Adjusted Life Expectancy. *Statistics Canada, Analytical Studies Branch Research Paper Series*, No. 34.

Wolfson MC (1992¹) POHEM - A Framework For Understanding and Modelling the Health of Human Populations. *Statistics Canada, Analytical Studies Branch Research Paper Series*, No. 44.

Wolfson MC and Manton KG (1992²) A Review of Models of Population Health Expectancy: A Micro-Simulation Perspective. *Statistics Canada, Analytical Studies Branch Research Paper Series*, No. 45.

Wolfson MC and Berthelot J-M. The Burden of CHD, Hypercholesteremia, and Smoking - Exploratory Simuations Using POHEM. *Unpublished*.

Zhuo ZQ, Ackerman E, Gatewood L and Kottke T (1991¹) Polychotomous multivariate models for coronary heart disease simulation. III. Model sensitivities and risk factor interventions. *International Journal of Bio-Medical Computing* **28**(3): 205-20.

Zhuo ZQ, Ackerman E, Gatewood L, Kottke T, Wu SC and Park HA (1991²) Polychotomous multivariate models for coronary heart disease simulation. II. Comparisons of risk functions. *International Journal of Bio-Medical Computing* **28**(3): 181-204.

Zhuo ZQ, Ackerman E, Gatewood L, Kottke T, Wu SC and Park HA (1991³) Polychotomous multivariate models for coronary heart disease simulation. I. Tests of a logistic model. *International Journal of Bio-Medical Computing* **27**(2): 133-48.

Zhuo ZQ, Tsai YJ, Ackerman E and Gatewood L (1994) Polychotomous multivariate models for coronary heart disease simulation. IV. The impact of physiological aging. *International Journal of Bio-Medical Computing* 37(3): 287-96.

Section 6: Appendices

Appendix A – Prevent Input Files

- DAT1INST.DAT - Prevent Log

Population Data:

- AMORT.DAT - general mortality per 100,000, 1 year age groups.
- BIRTH.DAT - birth projections from the base year to base year + 50, absolute numbers.
- EXPECTAT.DAT - expectation of life in the base year, 1 year age groups.
- POP.DAT - population structure in the base year in 1 year age groups.

Risk Factor Data:

- RF1BEMI.DAT - percentage outflow as a percentage of the exposed to cigarette smoking.
- RF1BEPL.DAT - percentage inflow as a percentage of the exposed to cigarette smoking.
- RF1EXP.DAT - exposure to the risk factor cigarette smoking, England and Wales 1991, 6 age groups, 3 exposure categories: 0-9, 10-19, 20 or more cigarettes.
- RF1RR1.DAT - relative risks of lung cancer, risk factor smoking, standard Dutch data set, 6 age groups, 3 exposure categories.
- RF1RR2.DAT - relative risks of COLD, risk factor smoking, standard Dutch data set, 6 age groups, 3 exposure categories.
- RF1RR3.DAT - relative risks of CHD, risk factor smoking, standard Dutch data set, 6 age groups, 3 exposure categories.
- RF2COMI.DAT - calculation options: cohort, percentage outflow as a percentage of the exposed to hypertension.
- RF2COPL.DAT - calculation options: cohort, percentage inflow as a percentage of the exposed to hypertension.
- RF2LFMI.DAT - calculation options: age groups, percentage outflow as a percentage of the exposed to hypertension.

- RF2LFPL.DAT - calculation options: age groups, percentage inflow as a percentage of the exposed to hypertension.
- RF2EXP.DAT - exposure to the risk factor hypertension, England and Wales 1991, 6 age groups, 2 exposure categories: hypertension based on diastolic blood pressure - mild (90-94 mmHg), severe (95 mmHg or more).
- RF2RR1.DAT - relative risks of CHD, risk factor hypertension, standard Dutch data set, 6 age groups, 2 exposure categories.
- RF2RR2.DAT - relative risks of CVA, risk factor hypertension, standard Dutch data set, 6 age groups, 2 exposure categories.
- RF3BEMI.DAT - outflow trends for exposure to cholesterol.
- RF3BEPL.DAT - inflow trends for exposure to cholesterol.
- RF3EXP.DAT - exposure to the risk factor cholesterol, England and Wales 1991, 6 age groups, 2 exposure categories: hypercholesterolemia - mild (6.6 - less than 7.8 mmol/l), severe (7.8 mmol/l or more).
- RF3RR1.DAT - relative risks of CHD, risk factor cholesterol, standard Dutch data set, 6 age groups, 2 exposure categories.
- RF4BEMI.DAT - outflow trends for exposure to alcohol drinking.
- RF4BEPL.DAT - inflow trends for alcohol drinking.
- RF4EXP.DAT - exposure to the risk factor alcohol drinking, England and Wales 1991, 6 age groups, 2 exposure categories: low (0 - 10 units), high (22 units or more).
- RF4RR1.DAT - relative risks of CHD, risk factor alcohol drinking, standard Dutch data set, 6 age groups, 2 exposure categories.
- RF4RR2.DAT - relative risks of cirrhosis, risk factor alcohol drinking, standard Dutch data set, 6 age groups, 2 exposure categories.
- RF4RR3.DAT - relative risks of accidental falls, risk factor alcohol drinking, standard Dutch data set, 6 age groups, 2 exposure categories.
- RF4RR4.DAT - relative risks of traffic accidents, risk factor alcohol drinking, standard Dutch data set, 6 age groups, 2 exposure categories.
- RF5BEMI.DAT - outflow trends for exposure to obesity.
- RF5BEPL.DAT - inflow trends for obesity.

- RF5EXP.DAT - exposure to the risk factor obesity, England and Wales 1991, 6 age groups, 2 exposure categories: mild (BMI over 25 - 30), severe (BMI over 30).
- RF5RR1.DAT - relative risks of breast cancer, risk factor obesity, standard Dutch data set.

Disease Mortality Data:

- ZMORS1.DAT - mortality/100,000 from lung cancer, 5 year age groups, England and Wales 1991.
- ZMORS2.DAT - mortality/100,000 from COLDC, 5 year age groups, England and Wales 1991.
- ZMORS3.DAT - mortality/100,000 from IHD, 5 year age groups, England and Wales 1991.
- ZMORS4.DAT - mortality/100,000 from CVA, 5 year age groups, England and Wales 1991.
- ZMORS5.DAT - mortality/100,000 from cirrhosis, 5 year age groups, England and Wales 1991.
- ZMORS6.DAT - mortality/100,000 from accidental falls, 5 year age groups, England and Wales 1991.
- ZMORS7.DAT - mortality/100,000 from traffic accidents, 5 year age groups, England and Wales 1991.
- ZMORS8.DAT - mortality/100,000 from breast cancer, 5 year age groups, England and Wales 1991.

Appendix B - The Prevent Log File: DAT1INST.DAT

1989	- base year of simulation
5 8	- 5 risk factors, 8 diseases/outcomes
cig. smoking	
hypertension	
cholesterol	- risk factors
alcohol	
obesity	
lung cancer	
COLD	
IHD	
CVA	
cirrhosis	- causes of death (1: lung cancer, 2: COLD, 3: IHD, etc)
accidental fall	
traffic accidents	
breast cancer	
3	- number of causes of death linked to the 1 st risk factor: cigarette smoking
1 10 4	
2 10 10	- cause of death number, LAG and LAT,
3 5 0	e.g. 1 10 4 signifies lung cancer, LAG = 10 years, LAT = 4 years.
5	- number of age groupings
20-24	
25-34	
35-49	- age grouping labels
50-59	
60+	
19	
24	
34	
49	- end years of age groupings
59	
95	
3	- number of risk factor exposure categories
1-12	
13-22	- risk factor exposure category labels (number of cigarettes smoked per day)
23+	
2	- the above sections repeated for the next risk factor: hypertension
3 2 0	
4 1 0	
5	
35-44	
45-49	
50-54	
55-59	
60+	
34	
44	
49	

54
59
95
2
mild
severe

1 - *cholesterol settings*
3 3 0
6
35-39
40-44
45-49
50-54
55-59
60+

34
39
44
49
54
59
95
2
mild
severe

4 - *alcohol settings*
3 1 0
5 1 4
6 1 0
7 1 0
2

20-39
40+
19
39
95
2
excessive
abstainers

1 - *obesity settings*
8 1 1
2
40-49
50+
39
49
95
1
QI>30

Appendix C -

Moving on - International perspectives on promoting physical activity (Health Education Authority 1994)

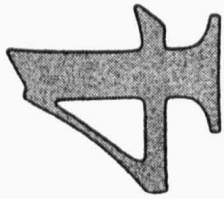

Setting targets: what are the potential health gains

Margaret Thorogood, Bhash Naidoo and Kim McPherson
Health Promotion Sciences Unit, London School of Hygiene and Tropical Medicine, Keppel Street, London WC1E 7HT

■ Background

In the evaluation of health promotion initiatives the long time scales necessary to evaluate the effect of each intervention is a major problem. A partial solution to this problem is the use of computer models which allow us to simulate the effects of different intervention scenarios, projecting the results over generations. Such models can be useful policy tools, but although they may seem easy to use, it is important to have a firm understanding of how they work and the assumptions made in order to understand fully the extent to which the results can be relied upon. We shall discuss both these issues further.

The project we report here aims to test the effect of a number of interventions for increasing the level of physical activity in the population.

■ Physical activity targets

We have taken as our guideline the targets for physical activity recently proposed by the Task Force on Physical Activity. These targets aim to increase both the frequency and the intensity of people's physical activity. The targets are:

- Target 1: to reduce by at least 50% the

proportion of men and women aged 16 to 74 taking no occasion of moderate physical activity of at least 30 minutes (in the preceding four weeks) by 2005.

- Target 2: to increase the percentages of men and women aged 16 to 74 taking a minimum of 30 minutes of at least moderate physical activity on five days a week by at least 15% by 2005.
- Target 3: to increase the percentages of men and women aged 16 to 64 taking on average three periods of vigorous activity for 20 minutes duration a week by at least 9% by 2005.

These targets formed the basis for the modelling, within the restraint imposed by the model.

■ The model - Prevent

Prevent (Gunning-Scheper, 1989) is a relatively user friendly model that was developed by Professor Louise Gunning (now based in Amsterdam), for her PhD in 1988. It is a cell-based simulation model that can estimate the health benefits for a population of changes in risk factor prevalence due to trends and interventions, both in terms of proportional changes in disease-specific incidence and in terms of absolute

changes in such parameters as disease-specific and total mortality. The underlying assumptions of the model include:

- The possibility that one risk factor affects several diseases, and that one disease is affected by several risk factors.
- A time dimension to simulate the reduction in excess risk after cessation of exposure to the risk factor.
- The interaction between the effect of the intervention and the demographic evolution in the population.

After the user has specified the risk factor to be intervened upon, the model first calculates the autonomous development, using trends. Then the user specifies change in risk factor prevalences after the intervention and the model calculates the development due to the intervention and the trends. Next the model calculates the autonomous development of all other risk factors that share diseases with the intervention risk factors. Finally the results of the calculations are applied to two populations - one with only the autonomous developments, and the other with both the autonomous developments and the intervention effects. The differences between the two populations are attributed to the intervention, with the output given in terms of total and disease specific mortality. See Appendix 4.1 for the risk equations used by the model.

■ Problems with Prevent

The main drawback to Prevent is that it only gives results of interventions in terms of mortality, with no output on either morbidity or cost. Prevent imposes a restriction on age group divisions which must always begin with a multiple of five, this means one has to model 15-24s rather

than 16-24s. One important anomaly is that when using the 'up to 95' option, there is an excess of deaths during the final years of the simulation, since someone whose death is prevented at an earlier age still has eventually to die. Unfortunately Prevent offers only one other option 'up to 65', which even though it caused severe restrictions, was the only sensible option.

■ Adapting Prevent

The standard version of Prevent was designed to simulate a Dutch population, with a base year of 1985, and this has been adapted by the Health Gain Project team to a simulated English and Welsh population, with a base year of 1991. This conversion entailed the input of data on the population structure, the general mortality rates, the life expectancies, the birth projections, the risk factor prevalences and the disease specific rates for the English and Welsh population.

■ Modelling exercise

Computer modelling of varying rates of physical activity of the population with respect to their effect on coronary heart disease (CHD) has not been explored to any great extent, and physical activity is not a present factor in Prevent. Since a sedentary lifestyle has been shown to be a powerful risk factor for the development of CHD this is an important omission.

In this paper we describe the results of modelling the effect of physical activity using Prevent, with lack of exercise as an independent risk factor for CHD. No interaction between physical activity and other risk factors has been built into the model since it was felt that there was insufficient evidence to make valid quantitative changes to other risk factors. We have

Table 4.1 Relative risk estimates for various activity levels using Hypotheses A and B

Hypothesis A		Hypothesis B	
Exercise Levels	Relative Risk	Exercise Levels	Relative Risk
Vigorous	1.0	Vigorous	1.0
Moderate	1.4	Moderate	1.5
Light	1.7*	Light	1.5
Sedentary	1.9	Sedentary	1.5

*From interpolation.
(Based on calculations by Berlin & Colditz, 1990.)

tested two alternative hypotheses:

- Hypothesis A: that there is an inverse relationship between CHD risk and physical activity, as proposed by Shaper & Wannamethee, 1991 (i.e. a graded effect).
- Hypothesis B: that only vigorous physical activity decreases CHD risk, as proposed by Morris *et al.*, 1990 (i.e. a threshold effect).

■ Relative risks of inactivity

In order to build a model, realistic relative risks for CHD mortality associated with physical inactivity were needed. After reviewing the literature it was decided to use the relative risk estimates shown in Table 4.1, as calculated by Berlin & Colditz (1990) in their meta-analysis, since there are no studies that calculate the risk separately for all age groups and both sexes.

■ Population prevalence of inactivity

The principle source of information on physical activity in the England and Wales population is the Allied Dunbar National Fitness Survey (ADNFS, Main findings, 1992). Unfortunately the levels of physical

activity, for which the relative risks are given, do not correspond to those of the ADNFS, which divides physical activity into six levels. Therefore the ADNFS levels had to be approximately equated to the levels of vigorous, moderate, light and sedentary exercise. This has been done for both 20 minute exercise periods at least three times a week and 30 minute exercise periods at least five times a week. The figures in Appendix 4.2 show the aggregated ADNFS (study conducted, 1990, unpublished) and HEA's National Survey of Activity and Health (HEANSAH, study conducted, 1991, unpublished) prevalences of physical activity, which have been taken as those for the population, and the readjusted exercise levels.

■ Assumptions of the model

- The assumptions included were that:
- upon taking up exercise, a person's relative risk begins to decrease immediately;
 - after one year of taking up a new level of exercise a person's relative risk decreases to that of people exercising at that level;
 - lack of physical activity only increases the risk of CHD and not the risk of other diseases;

■ each intervention is responsible for changing people's behaviour permanently;

■ there are no background risk factor trends in the population, i.e. without an intervention there would be no change over time in rates of physical activity;

■ the youngest intervention age is 15 years, since 16 is not a multiple of 5;

■ the output is calculated for age groups 'up to 65' because there is an excess in deaths when using the only other option 'up to 95';

■ the interventions begin in 1994 and continue for 11 years, with the target prevalences being achieved by 2005.

The most important of all these assumptions is the one using the option 'up to 65' group, since excluding the effects in the population aged 65-74, where most of the CHD deaths would occur, will result in an underestimation of the health gain.

Exercise interventions

The interventions modelled have been derived from the targets set by the Physical Activity Task Force. All the interventions will be simulated using Hypothesis A, and those that shift people into the vigorous exercise group will also be simulated using Hypothesis B. See Appendix 4.3 for estimated prevalences of exercise after the interventions.

Four intervention scenarios have been modelled:

A. The three targets described under 'Physical activity targets' would be applied evenly throughout the population.

B. Achieving the targets by concentrating the changes only in the youngest age groups: Target 1 - 16 to 54; Target 2 - 16

to 34; Target 3 - 16 to 34.

C. Achieving the targets by concentrating the changes only in those people over 35.

D. Achieving the targets by concentrating the changes only in the oldest age groups: Target 1 - 45 to 64; Target 2 - 45 to 64; Target 3 - 55 to 64.

The age inconsistencies of interventions B and D are due to the structure of the population, since there are not enough people in some of the age groups to achieve the necessary percentage changes that the targets set for the total population.

In simulating the Target 1 scenario the intervention increased the level of physical activity of the sedentary group to the level of the moderate group. The Target 2 scenario was simulated with the interventions which increased the physical activity of the least active, i.e. the sedentary exercisers, and which increased the physical activity of the moderately active, i.e. the moderate exercisers, being modelled separately to provide lower and upper limits for the effectiveness of the intervention. The Target 3 scenario was simulated with the interventions which increased the physical activity of the least active, i.e. the sedentary and light exercisers, and which increased the physical activity of the moderately active and light exercisers, being modelled separately to provide lower and upper limits for the effectiveness of the intervention.

Intervention outputs

Measures of output from the simulated interventions have been produced as follows:

1. Ischaemic heart disease (IHD) mortality rate (/1000)/year.
2. Total mortality reduction.
3. Actual years of life gained.

Results

Threshold versus gradual effect

Figures 4.1, 4.2, 4.3 and 4.4 show the different reductions in IHD death rate which would be achieved with the assumption implicit in Hypotheses A and B (see under 'Modelling Exercise'). For Hypothesis A (graded effect) all three targets achieve reductions in mortality. For Hypothesis B (threshold effect) only Target 3 (increasing the proportion taking vigorous exercise) has any effect.

While the scientific evidence is still not conclusive, examining the effect of the three targets becomes meaningless if Hypothesis B is adopted. The remainder of this contribution is based on the assumption that Hypothesis A holds.

Reduction in IHD death rate

There is a small reduction in the death rate

Setting targets: what are the potential health gains

for men and women from IHD associated with achievement of each of the three targets (Figures 4.1 and 4.2). This represents a fall of between 0.1% and 0.4% in men, and 0.04% and 0.13% in women. Assuming that all three targets were achieved, there might be a reduction of a little less than 1% in the IHD death rate in men, and a smaller reduction in women. Targets 1 and 2, which would affect many more people, but involve lower levels of exercise, show much greater potential for reductions in IHD mortality.

In the case of Targets 2 and 3, which involve increasing activity to moderate or vigorous levels, then the size of the reduction achieved is influenced by whether the population who achieve the increased exercise level is drawn from those already taking some exercise (lightly or moderately active) or from those who are sedentary (least active). This is shown in Figures 4.5 and 4.6. The greatest effect can be achieved by moving the sedentary people into the

All Targets - A - men aged under 65

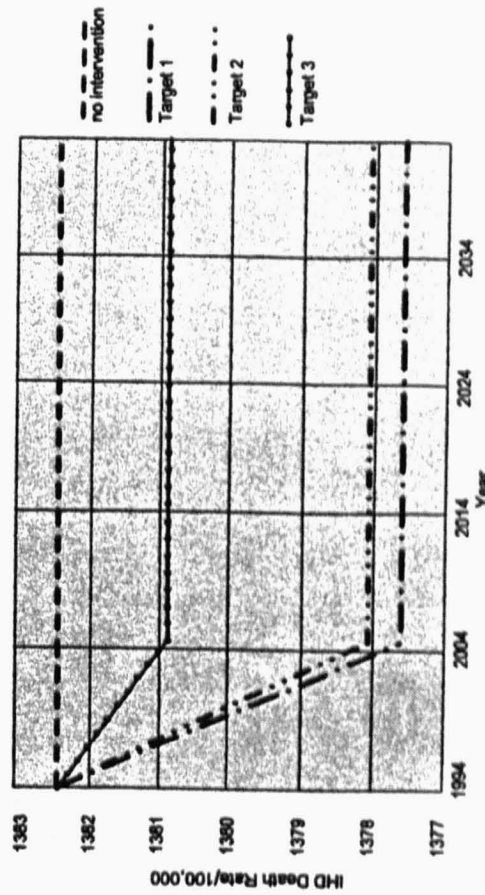

Figure 4.1. Change in ischaemic heart disease (IHD) mortality rate in men aged under 65 with and without achieving all three targets, assuming Hypothesis A (graded effect).

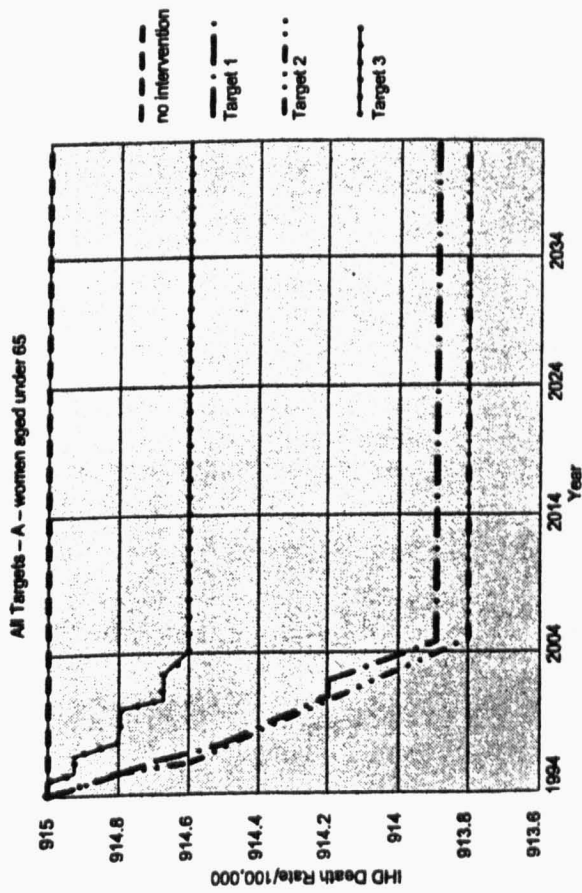

Figure 4.2. Change in ischaemic heart disease (IHD) mortality rate in women aged under 65 with and without achieving all three targets, assuming Hypothesis A (graded effect).

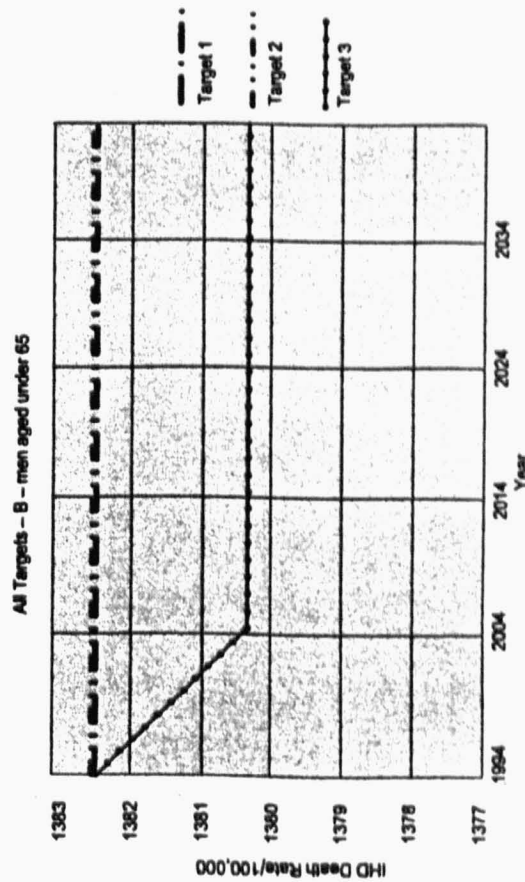

Figure 4.3. Change in ischaemic heart disease (IHD) mortality rate in men aged under 65 with and without achieving all three targets, assuming Hypothesis B (threshold effect).

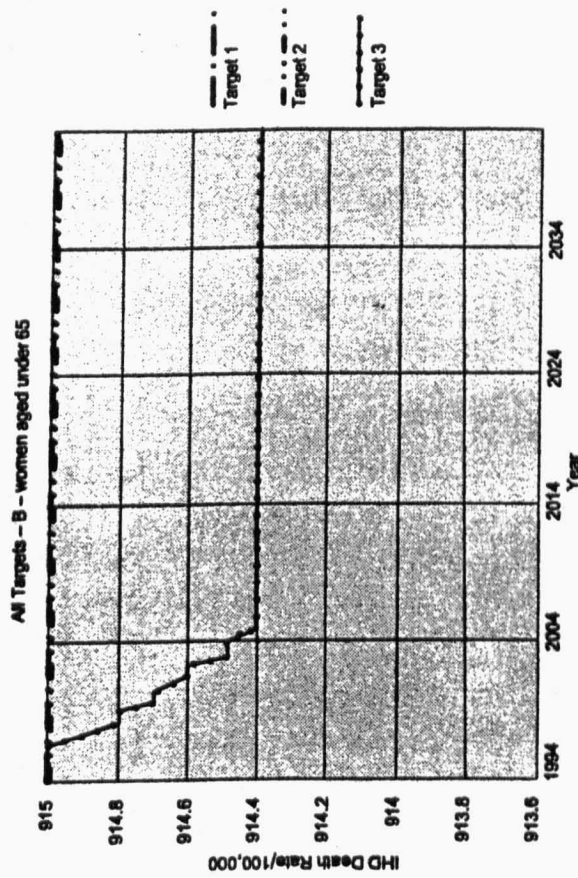

Figure 4.4. Change in ischaemic heart disease (IHD) mortality rate in women aged under 65 with and without achieving all three targets, assuming Hypothesis B (threshold effect).

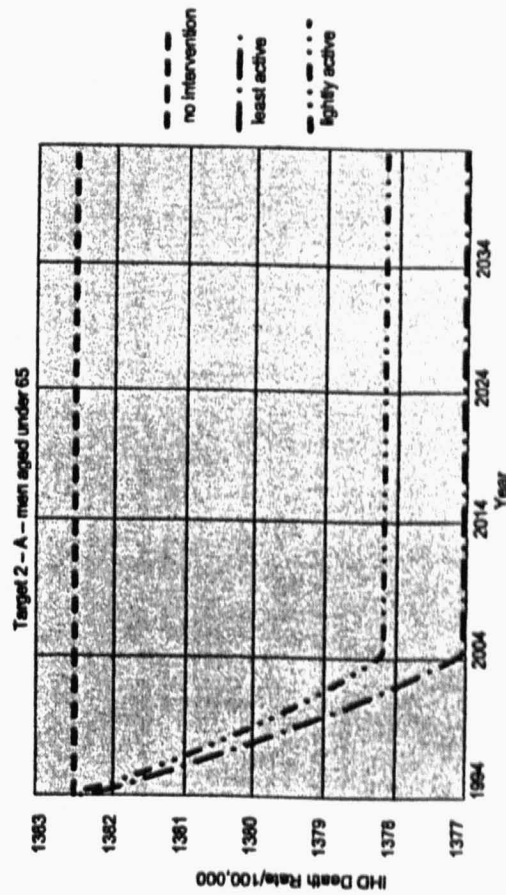

Figure 4.5. Change in ischaemic heart disease (IHD) mortality rate in men aged under 65 with and without achieving Target 2, intervening on the least and lightly active, assuming Hypothesis A (graded effect).

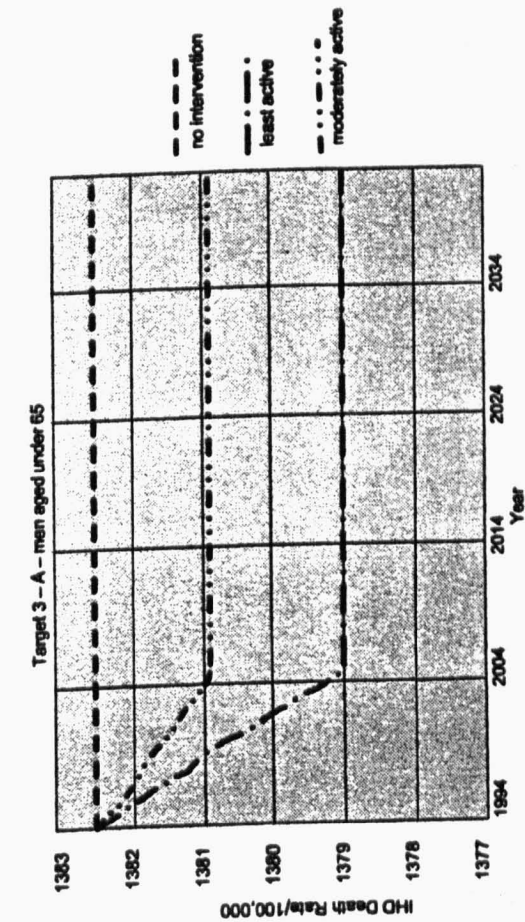

Figure 4.6. Change in ischaemic heart disease (IHD) mortality rate in men aged under 65 with and without achieving Target 3, intervening on the least and moderately active, assuming Hypothesis A (graded effect).

moderate or vigorous categories, but, in reality, it is much more likely that those already taking some exercise will move into the next highest exercise category, and this is therefore the assumption which has been used in the rest of the modelling.

Reduction in total mortality

While the proportional reduction in the death rate may appear disappointing, the actual number of deaths under age 65 postponed each year is not insubstantial (Figure 4.7). The variations in the numbers of deaths postponed are a reflection of the expected variation in the size and age structure of the population. In general, achieving Target 1 can be expected to postpone the deaths of around 1700 people a year. Achieving Target 2 would result in a slightly smaller number of deaths postponed, while achieving Target 3 would be expected to postpone only around 600 or less deaths a year.

Life years gained

Figures 4.8 and 4.9 show the same effects in terms of life years gained. These two figures are on the same scale, and it can be clearly seen that achieving the targets in men will result in a much greater saving in life years.

Age groups

To examine the differing effect of targeting exercise interventions at differing age groups, we have modelled the life years gained for each of the three targets making the assumptions that the target would be achieved by concentrating on the oldest group (over 45), the older half of the population (age 35-64) and the youngest group (under 44). Figures 4.10 and 4.11 show this comparison in men, while Figures 4.12 and 4.13 show the same results for women. It is very clear from these figures that, for men, the greatest gain

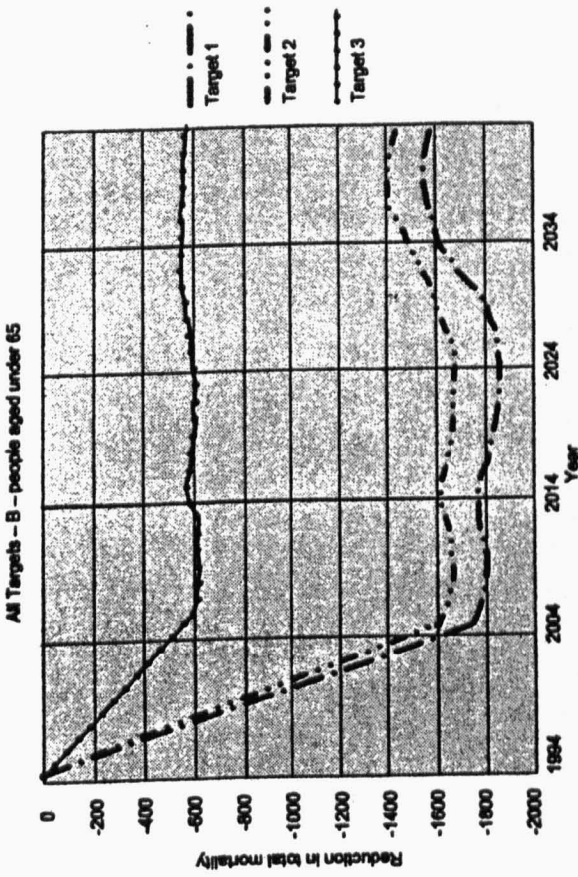

Figure 4.7. Reduction in total mortality for people aged under 65 with achieving all three targets, intervening on the lightly and moderately active, assuming Hypothesis A (graded effect).

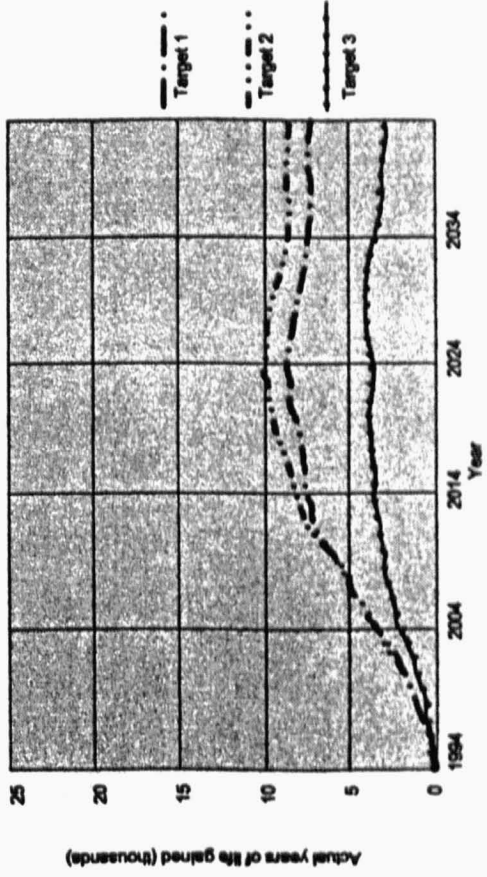

Figure 4.8. Actual years of life gained for men aged under 65 with achieving all three targets, intervening on the lightly and moderately active, assuming Hypothesis A (graded effect).

All Targets - A - women aged under 65

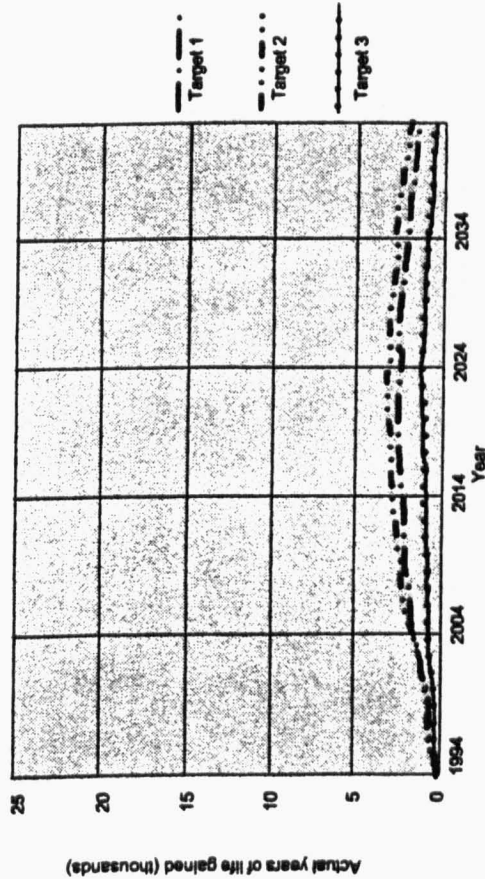

Figure 4.9. Actual years of life gained for women aged under 65 with achieving all three targets, intervening on the lightly and moderately active, assuming Hypothesis A (graded effect).

All Targets - A - men aged under 65

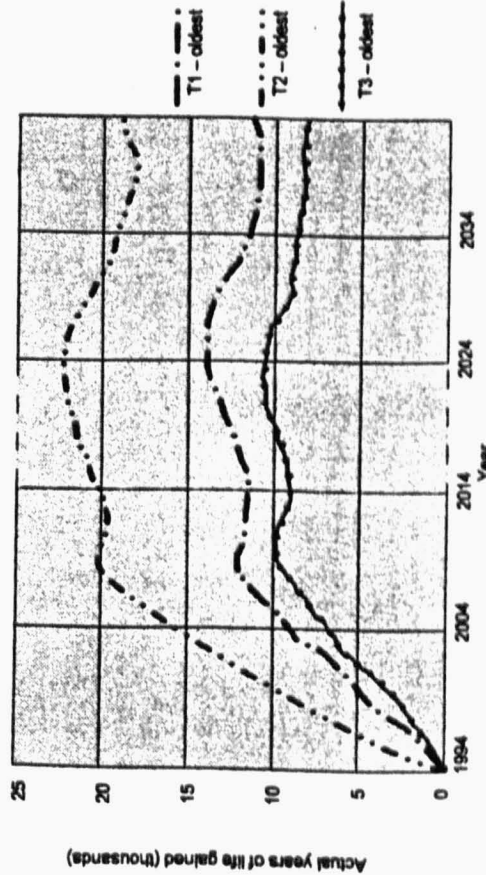

Figure 4.10. Actual years of life gained for men aged under 65 with achieving all three targets, intervening on only the oldest age groups, assuming Hypothesis A (graded effect).

All Targets - A - men aged under 65

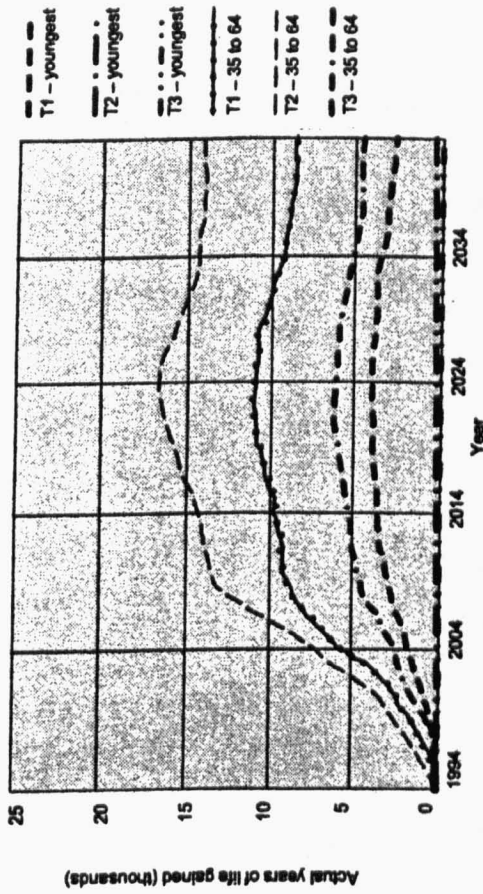

Figure 4.11. Actual years of life gained for men aged under 65 with achieving all three targets, intervening on only the youngest and the 35 to 64 age groups, assuming Hypothesis A (graded effect).

All Targets - A - women aged under 65

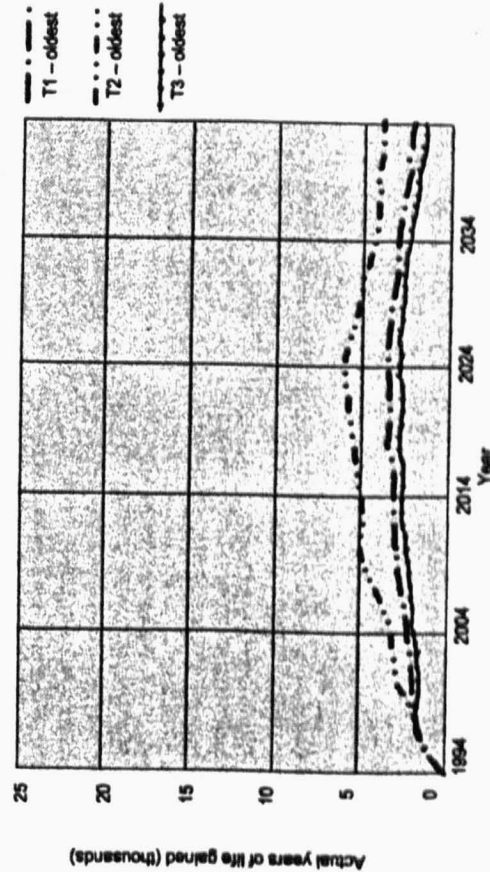

Figure 4.12. Actual years of life gained for women aged under 65 with achieving all three targets, intervening on only the oldest age groups, assuming Hypothesis A (graded effect).

All Targets - A - women aged under 65

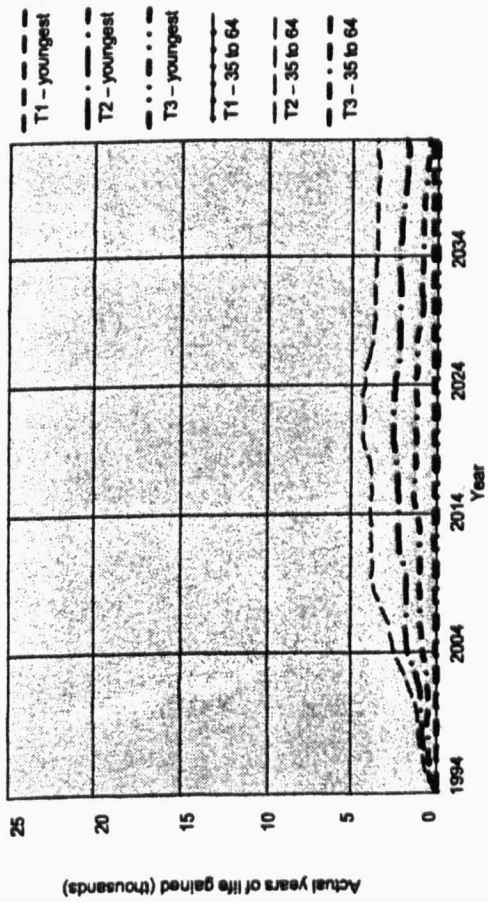

Figure 4.13. Actual years of life gained for women aged under 65 with achieving all three targets, intervening on only the youngest and the 35 to 64 age groups, assuming Hypothesis A (graded effect).

can be achieved by concentrating on the oldest men. There is less gain achievable in women, and there appears to be less difference between the effects of targeting different age groups.

Conclusions

These figures are presented to help clarify the expected effects of achieving the targets. They are far from perfect predictions, given the number of assumptions (discussed above) that have had to be made when developing the model. Maybe the most important limitation of the data as they stand is the omission of the effects on the population aged between 65 and 74 years, where the majority of the IHD deaths can

be expected to occur. However, it appears from these data that the most effective strategy would involve concentrating on men in the older age groups, and in particular those men who currently take no physical exercise.

Summary

- The most effective strategy would be:
 - Achieving Target 2.
 - Intervening on those over 45 years of age.
 - Concentrating on men.
 - Increasing the physical activity of the least active members of the population.

Appendix 4.1
Risk equations

- A: 1 year age index, A = Amin, ..., 95.
- Amin: lowest age at risk.
- t: index for time.
- i: index for time since cessation of exposure.
- LAG: the period it takes for the relative risk of the ex-exposed to come down to the lowest possible risk for the ex-exposed.
- LAT: the period between the end of exposure to the risk factor and the first effect on disease specific mortality.
- P_{i,t,A,i}: proportion exposed.
- P_{i,t,A,0}: proportion non-exposed.
- P_{i,t,A,1}: proportion ex-exposed after LAG years or more.
- P_{i,t,A,i}: i=2, ..., ID-1: proportion ex-exposed less than LAG years.
- ID = LAG + 1, i.e. the number of levels of exposure.
- IDR: Incidence Density Ratio, or relative risk factor - the ratio of incidence between exposed and non-exposed.
- ET: Etiologic Fraction - the proportion of the total incidence of the disease that can be attributed to the prevalence of a certain risk factor in the population.
- PIF: Potential Impact Fraction - the incidence that is avoided by a preventive intervention as a proportion of the incidence that would have occurred in that population without the intervention.
- TIF: Trend Impact Fraction - the incident cases prevented at a certain moment in time, by an autonomous change in risk factor prevalence, as a proportion of the incident cases that would have occurred at that time in the absence of change.
- cn: number of exposure categories.
- n: index for exposure category.
- rf: number of risk factors influencing disease z.
- r: index for risk factor.
- j: 0, 1: index for trend (0) or intervention population (1).

- s: index for sex.
- z = 1, ..., zt: index for disease.
- M^{s,A}: constant overall mortality quotient.
- M^{s,t,A}: adjusted overall mortality quotient.
- M^{s,t,A}: disease specific mortality quotient.
- B: number of births.

The IDRs are multiplied with the proportions exposed, and the product is summed to get the intermediate variable PIDR:

$$PIDR_{t,i,s,A} = \sum_{n=1}^{ID} P_{i,t,A,n}^{cn} IDR_{t,i,s,A,n}$$

These PIDRs are used to calculate ETs, TIFs and PIFs:

$$ET_{t,i,s,A} = \frac{PIDR_{t,i,s,A} - 1}{PIDR_{t,i,s,A}}$$

$$TIF_{t,i,s,A} = \frac{PIDR_{t,i,s,A} - PIDR_{t,i,s,A}^{rf}}{PIDR_{t,i,s,A}}$$

$$PIF_{t,i,s,A} = \frac{PIDR_{t,i,s,A} - PIDR_{t,i,s,A}^{rf}}{PIDR_{t,i,s,A}}$$

Next the TIFs and PIFs for the same disease are aggregated over risk factors:

$$PIF_{t,i,s,A} = 1 - \prod_{r=1}^{rf} [1 - PIF_{t,i,s,A}^r]$$

$$TIF_{t,i,s,A} = 1 - \prod_{r=1}^{rf} [1 - TIF_{t,i,s,A}^r]$$

For the non-intervention population these TIFs are applied to adjust the disease specific mortality quotient, while both the

PIFs and TIFs are applied for the intervention population:

$$M_i^{0,t+1} = M_i^{t,t} - \sum_{s=1}^{st} TIF_i^{s,t+1} M_i^{t,t}$$

$$M_i^{t+1,t} - M_i^{t,t} - \sum_{s=1}^{st} [1 - (1 - TIF_i^{s,t+1})(1 - PIF_i^{s,t+1})] M_i^{t,t}$$

These two sets of mortality quotients are used to calculate the next year's non-

intervention and intervention populations using the following expressions:

$$POP_i^{t+1,0} = 0.485B_i(1 - M_i^{t+1,0})$$

$$POP_i^{t+2,0} = 0.515B_i(1 - M_i^{t+2,0})$$

$$POP_i^{t+3,1} = POP_i^{t+3,0} - 1(1 - M_i^{t+3,1})$$

From these equations most of the output measures are calculated.

Appendix 4.2

Bar charts

Physical Activity Levels - Men
30 minutes, at least 5 times a week

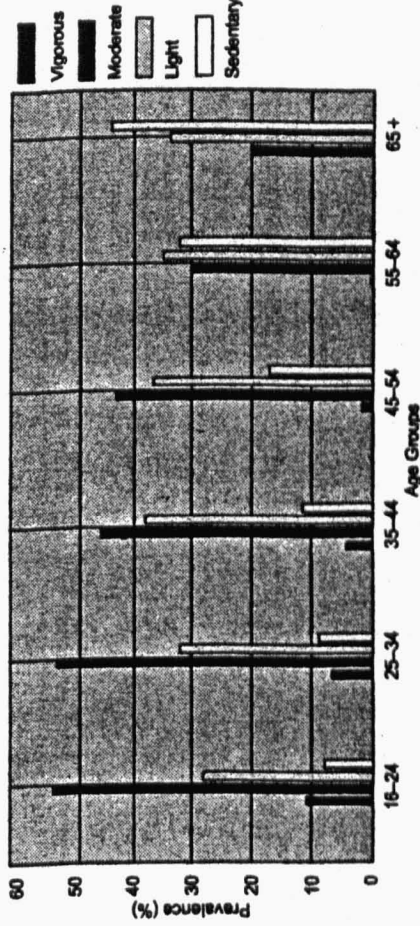

Figure A4.2.1

Physical Activity Levels - Women
30 minutes, at least 5 times a week

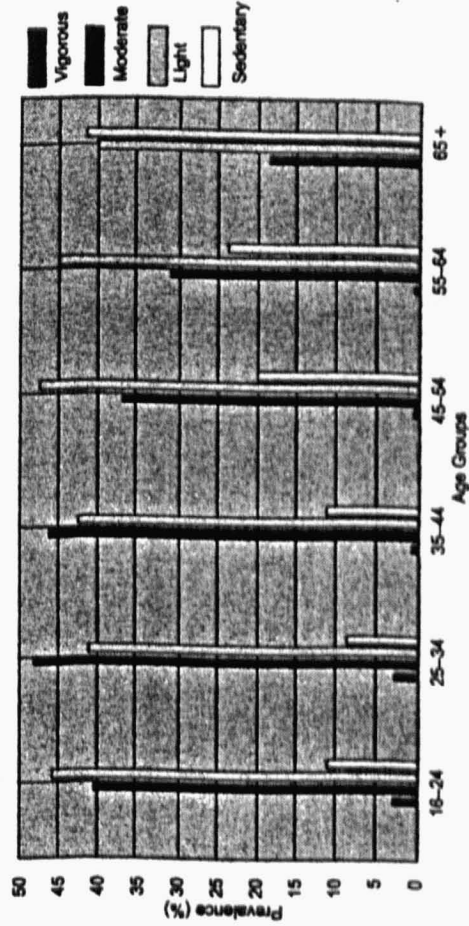

Figure A4.2.2

Physical Activity Levels – Men
20 minutes, at least 3 times a week

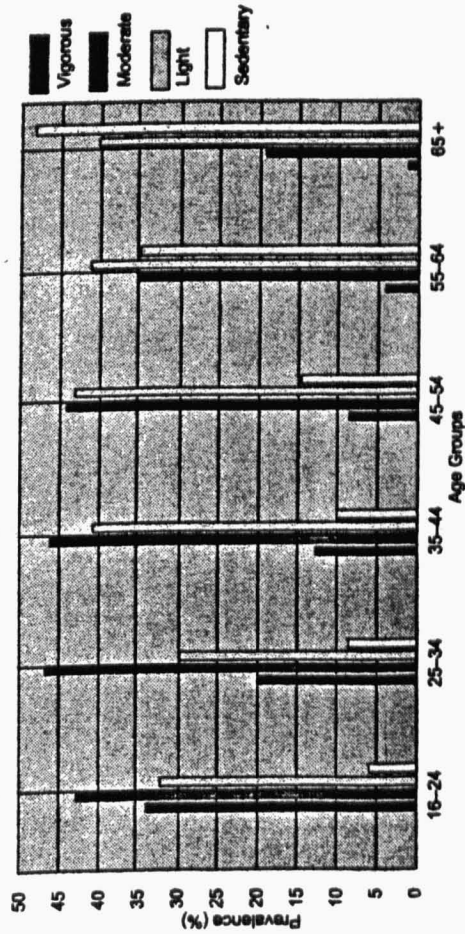

Figure A4.2.3

Physical Activity Levels – Women
20 minutes, at least 3 times a week

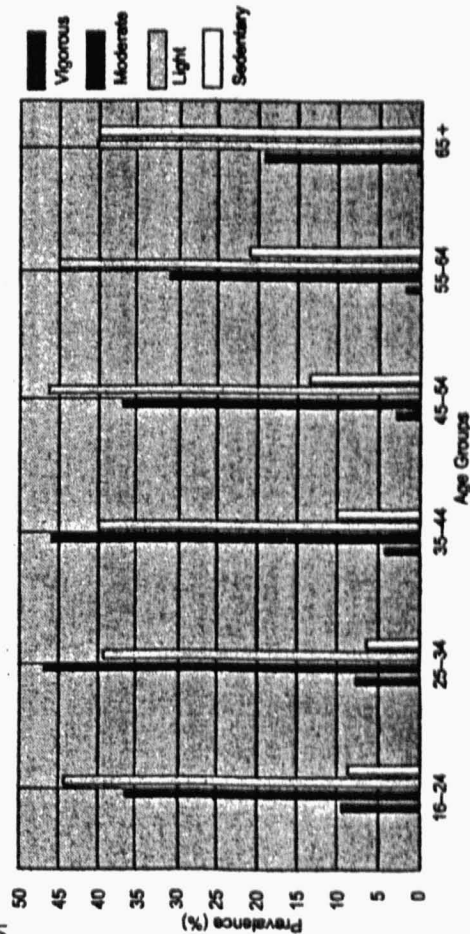

Figure A4.2.4

Appendix 4.3

Pre- and post-intervention prevalence of physical activity for England and Wales

The following tables show the initial prevalence of physical activity contained in the Prevent models, and the prevalence of physical activity on completing the interventions under the four scenarios outlined on page 80 targeted at various groups of exercisers (see page 77).

Initial prevalence - 30 minutes of physical activity, at least five times a week

Exercise level	Age groups (%)					
	16-24	25-34	35-44	45-54	55-64	65+
Men						
Vigorous	10.6	6.5	4.2	1.4	0.4	0.0
Moderate	53.5	52.6	45.8	44.6	30.5	20.1
Light	28.9	32.0	39.0	38.0	37.1	35.9
Sedentary	7.0	8.9	11.0	16.0	32.0	44.0
Women						
Vigorous	2.9	2.8	0.5	0.4	0.4	0.0
Moderate	40.2	48.2	46.6	36.9	31.4	18.0
Light	46.0	41.0	42.0	47.8	45.1	39.9
Sedentary	10.9	6.0	10.9	14.9	23.1	42.1

Initial prevalence - 20 minutes of physical activity, at least three times a week

Exercise level	Age groups (%)					
	16-24	25-34	35-44	45-54	55-64	65+
Men						
Vigorous	28.9	20.4	12.8	6.4	4.1	1.4
Moderate	37.7	41.6	40.8	38.9	29.8	19.6
Light	27.8	30.1	36.5	38.1	36.5	35.9
Sedentary	5.6	7.9	9.9	14.6	29.6	43.1
Women						
Vigorous	9.7	7.6	4.1	2.9	1.8	0.2
Moderate	37.1	46.5	46.0	37.3	31.6	19.5
Light	44.5	39.4	40.0	46.3	45.3	40.3
Sedentary	8.7	6.5	9.9	13.5	21.1	40.0

Post-intervention prevalence on achieving Target 1 using scenario A

Exercise level	Age groups (%)					
	16-24	25-34	35-44	45-54	55-64	65+
Men						
Vigorous	10.6	6.5	4.2	1.4	0.4	0.0
Moderate	53.5	52.6	45.0	44.6	30.5	20.1
Light	32.5	36.4	44.5	46.1	53.2	35.9
Sedentary	3.4	4.5	5.5	7.9	15.9	44.0
Women						
Vigorous	2.9	2.8	0.5	0.4	0.4	0.0
Moderate	40.2	40.2	46.6	36.9	31.4	18.0
Light	51.5	45.1	47.5	55.3	56.7	39.9
Sedentary	5.4	3.9	5.4	7.4	11.5	42.1

Post-intervention prevalence on achieving Target 1 using scenario B

Exercise level	Age groups (%)					
	16-24	25-34	35-44	45-54	55-64	65+
Men						
Vigorous	10.6	6.5	4.2	1.4	0.4	0.0
Moderate	53.5	52.5	45.8	44.6	30.5	20.1
Light	35.9	40.9	50.0	46.1	37.1	35.9
Sedentary	0.0	0.0	0.0	7.9	32.0	44.0
Women						
Vigorous	2.9	2.8	0.5	0.4	0.4	0.0
Moderate	40.2	48.2	46.6	36.9	31.4	18.0
Light	56.9	49.0	52.9	50.6	45.1	39.9
Sedentary	0.0	0.0	0.0	12.1	23.1	42.1

Post-intervention prevalence on achieving Target 1 using scenario C

Exercise level	Age groups (%)					
	16-24	25-34	35-44	45-54	55-64	65+
Men						
Vigorous	10.6	6.5	4.2	1.4	0.4	0.0
Moderate	53.5	52.6	45.8	44.6	30.5	20.1
Light	28.9	32.0	46.8	48.5	56.2	35.9
Sedentary	7.0	8.9	3.2	5.5	12.9	44.0
Women						
Vigorous	2.9	2.8	0.5	0.4	0.4	0.0
Moderate	40.2	48.2	46.6	36.9	31.4	18.0
Light	46.0	41.0	50.4	58.6	60.2	39.9
Sedentary	10.9	8.0	2.5	4.1	8.0	42.1

Post-intervention prevalence on achieving Target 1 using scenario D

Exercise level	Age groups (%)					
	16-24	25-34	35-44	45-54	55-64	65+
Men						
Vigorous	10.6	6.5	4.2	1.4	0.4	0.0
Moderate	53.5	52.6	45.8	44.6	30.5	20.1
Light	28.9	32.0	39.0	46.1	69.1	35.9
Sedentary	7.0	8.9	11.0	7.9	0.0	44.0
Women						
Vigorous	2.9	2.8	0.5	0.4	0.4	0.0
Moderate	40.2	40.2	46.6	36.9	31.4	18.0
Light	46.0	41.0	42.0	60.0	60.2	39.9
Sedentary	10.9	8.0	10.9	2.7	0.0	42.1

Post-intervention prevalence on achieving Target 2, targeting the least active exercisers using scenario A

Exercise level	Age groups (%)					
	16-24	25-34	35-44	45-54	55-64	65+
Men						
Vigorous	10.6	6.5	4.2	1.4	0.4	0.0
Moderate	68.4	67.5	60.8	59.6	45.5	20.1
Light	21.0	26.0	35.0	38.0	37.1	35.9
Sedentary	0.0	0.0	0.0	1.0	17.0	44.0
Women						
Vigorous	2.9	2.8	0.5	0.4	0.4	0.0
Moderate	55.3	63.3	61.6	52.0	46.5	18.0
Light	41.6	33.9	37.9	47.6	45.1	39.9
Sedentary	0.0	0.0	0.0	0.0	8.0	42.1

Post-intervention prevalence on achieving Target 2, targeting the lightly active exercisers using scenario A

Exercise level	Age groups (%)					
	16-24	25-34	35-44	45-54	55-64	65+
Men						
Vigorous	10.6	6.5	4.2	1.4	0.4	0.0
Moderate	68.4	67.5	60.8	59.6	45.5	20.1
Light	14.0	17.0	24.0	23.0	22.1	35.9
Sedentary	7.0	8.9	11.0	16.0	32.0	44.0
Women						
Vigorous	2.9	2.8	0.5	0.4	0.4	0.0
Moderate	55.3	63.3	61.6	52.0	46.5	18.0
Light	30.9	25.9	27.0	32.7	30.0	39.9
Sedentary	10.9	8.0	10.9	14.9	23.1	42.1

The setting of national physical activity targets in England

Post-intervention prevalence on achieving Target 2, targeting the least active exercisers using scenario B

Exercise level	Age groups (%)					
	16-24	25-34	35-44	45-54	55-64	65+
Men						
Vigorous	30.6	6.5	4.2	1.4	0.4	0.0
Moderate	86.4	93.5	46.2	44.6	30.5	20.1
Light	0.0	0.0	36.6	38.0	37.1	35.9
Sedentary	0.0	0.0	11.0	16.0	32.0	44.0
Women						
Vigorous	2.9	2.8	0.5	0.4	0.4	0.0
Moderate	77.5	85.4	46.6	36.9	31.4	18.0
Light	8.6	3.8	42.0	47.8	45.1	39.9
Sedentary	10.9	8.0	10.9	14.9	23.1	42.1

Post-intervention prevalence on achieving Target 2, targeting the lightly active exercisers using scenario C

Exercise level	Age groups (%)					
	16-24	25-34	35-44	45-54	55-64	65+
Men						
Vigorous	10.6	6.5	4.2	1.4	0.4	0.0
Moderate	53.5	52.6	70.2	69.1	54.9	20.1
Light	28.9	32.0	14.6	13.5	12.7	35.9
Sedentary	7.0	8.9	11.0	16.0	32.0	44.0
Women						
Vigorous	2.9	2.8	0.5	0.4	0.4	0.0
Moderate	40.2	40.3	71.7	62.0	56.5	18.0
Light	46.0	41.0	16.8	22.7	20.0	39.9
Sedentary	10.9	8.0	10.9	14.9	23.1	42.1

Post-intervention prevalence on achieving Target 2, targeting the lightly active exercisers using scenario D

Exercise level	Age groups (%)					
	16-24	25-34	35-44	45-54	55-64	65+
Men						
Vigorous	10.6	6.5	4.2	1.4	0.4	0.0
Moderate	53.5	52.6	45.8	63.1	71.1	20.1
Light	28.9	32.0	39.0	0.0	0.0	35.9
Sedentary	7.0	8.9	11.0	15.5	30.5	44.0
Women						
Vigorous	2.9	2.8	0.5	0.4	0.4	0.0
Moderate	40.2	40.3	46.6	76.4	71.1	18.0
Light	46.0	41.0	62.0	8.3	5.4	39.9
Sedentary	10.9	8.0	10.9	14.9	23.1	42.1

Setting targets: what are the potential health gains

Post-intervention prevalence on achieving Target 3, targeting the least active exercisers using scenario A

Exercise level	Age groups (%)					
	16-24	25-34	35-44	45-54	55-64	65+
Men						
Vigorous	37.92	29.38	21.83	17.4	13.09	1.4
Moderate	37.7	41.58	40.83	36.84	29.83	19.6
Light	24.38	29.04	36.5	38.14	36.48	35.9
Sedentary	0.0	0.0	0.83	5.62	20.6	43.1
Women						
Vigorous	18.76	16.62	13.12	11.96	10.73	0.2
Moderate	37.12	46.48	45.96	37.26	31.82	19.5
Light	44.12	36.9	39.97	46.27	45.27	40.3
Sedentary	0.0	0.0	0.83	4.51	12.18	40.0

Post-intervention prevalence on achieving Target 3, targeting the moderately active exercisers using scenario A

Exercise level	Age groups (%)					
	16-24	25-34	35-44	45-54	55-64	65+
Men						
Vigorous	37.92	29.38	21.83	17.4	13.09	1.4
Moderate	28.67	32.65	31.83	29.08	20.82	19.6
Light	27.77	30.07	36.5	38.13	36.48	35.9
Sedentary	5.64	7.9	9.83	14.59	29.61	43.1
Women						
Vigorous	18.76	16.62	13.12	11.96	10.73	0.2
Moderate	28.04	37.46	37.03	28.25	22.91	19.5
Light	44.54	39.44	39.97	46.27	45.27	40.3
Sedentary	8.66	6.48	9.88	13.53	21.09	40.0

Post-intervention prevalence on achieving Target 3, targeting the moderately active exercisers using scenario B

Exercise level	Age groups (%)					
	16-24	25-34	35-44	45-54	55-64	65+
Men						
Vigorous	52.14	43.81	12.8	8.4	4.1	1.4
Moderate	14.45	18.22	40.8	38.9	29.8	19.6
Light	27.77	30.07	36.5	38.1	36.5	35.9
Sedentary	5.64	7.9	9.9	14.6	29.6	43.1
Women						
Vigorous	31.96	30.0	4.1	2.9	1.8	0.2
Moderate	14.04	24.08	46.0	37.3	31.8	19.5
Light	44.54	39.44	40.0	46.3	45.3	40.3
Sedentary	8.66	6.48	9.9	13.5	21.1	40.0

The setting of national physical activity targets in England

Post-intervention prevalence on achieving Target 3, targeting the moderately active exercisers using scenario C

Exercise level	Age groups (%)					
	16-24	25-34	35-44	45-54	55-64	65+
Men						
Vigorous	28.9	20.4	27.5	23.02	18.67	1.4
Moderate	37.7	41.6	26.17	24.25	15.24	19.6
Light	27.8	30.1	36.5	36.14	36.48	35.9
Sedentary	5.6	7.9	9.83	14.59	29.61	43.1
Women						
Vigorous	9.7	7.6	19.14	18.03	16.91	0.2
Moderate	37.1	46.5	31.01	22.18	16.73	19.5
Light	44.5	39.4	39.97	46.27	45.27	40.3
Sedentary	8.7	6.5	9.88	13.52	21.09	40.0

Post-intervention prevalence on achieving Target 3, targeting the moderately active exercisers using scenario D

Exercise level	Age groups (%)					
	16-24	25-34	35-44	45-54	55-64	65+
Men						
Vigorous	28.9	20.4	12.8	6.4	55.36	1.4
Moderate	37.7	41.6	40.8	36.9	0.0	19.6
Light	27.8	30.1	36.5	30.1	15.03	35.9
Sedentary	5.6	7.9	9.9	14.6	29.61	43.1
Women						
Vigorous	9.7	7.6	4.1	2.9	50.36	0.2
Moderate	37.1	46.5	46.0	37.3	0.0	19.5
Light	44.5	39.4	40.0	46.3	28.55	40.3
Sedentary	8.7	6.5	9.9	13.5	21.09	40.0

References

Allied Dunbar National Fitness Survey: main findings (1992). Sports Council and Health Education Authority, London.

Berlin, J.A. & Colditz G.A. (1990). A meta-analysis of physical activity in the prevention of coronary heart disease. *American Journal of Epidemiology*, 132, 612-27.

Gunning-Scheper, L.J. (1989). The health benefits of prevention, a simulation approach. *Health Policy*, 12, 1-256.

Morris, J.N., Clayton, D.G., Everitt, M.G., Semmence, A.M. & Burgess, E.H. (1990). Exercise in leisure time: coronary attack and death rates. *British Heart Journal*, 63, 325-34.

Shaper, A.J. & Wannamethee, G. (1991). Physical activity and ischaemic heart disease in middle-aged British men. *British Heart Journal*, 66, 384-94.

**Appendix D - Chapter 7: Tables of the Figures :
Modelling the Effects of Increased Physical Activity
Using the Prevent Model**

Limit	Strategy 1		Strategy 2	
	Lower	Upper	Lower	Upper
Males	5613	9537	1866	4167
Females	1511	2556	501	1129

Table D.1 - Actual years of life gained for men and for women aged under 95 achieving each strategy by 2019

Age Groups	Strategy 1		Strategy 2	
	15 - 44	44 - 64	15 - 44	44 - 64
Males	968	20437	401	8238
Females	155	5675	64	2265

Table D.2 - Actual years of life gained for men and for women aged under 95 achieving each strategy by 2019, targeting by age group

Relative Risks Mode	Meta-Analysis		Modified			
	Age Group		Cohort			
Age Groups	15 - 44	44 - 64	15 - 44	44 - 64	15 - 44	44 - 64
Strategy 1	1123	26112	1123	23283	5573	29484
Strategy 2	465	10503	465	9104	2130	14321

Table D.3 - Actual years of life gained for men and for women aged under 95 achieving each strategy by 2019, targeting by age group, using modified relative risk and using the cohort option

Appendix E - *Modelling the effects of increased physical activity on coronary heart disease in England and Wales (Naidoo 1997).*

Modelling the effects of increased physical activity on coronary heart disease in England and Wales

Bhash Naidoo, Margaret Thorogood, Klim McPherson, Louise J Gunning-Schepers

Abstract

Objective - To investigate the use of computer models as tools for policy makers in evaluating physical activity interventions aimed at reducing deaths from coronary heart disease (CHD).

Design - The cell-based computer model *Prevent*, adapted to simulate risk factor interventions for an English and Welsh population, was used to simulate the effect of two strategies for increasing physical activity levels in respect of CHD mortality over 25 years. The first strategy involved a 25% increase in the proportion of 15-64 year olds who were moderately active, while the second strategy involved a similar increase in the proportion who were vigorously active. The effects of focusing on narrower age ranges and on people at different initial activity levels were also explored.

Main results - The simulations showed a small reduction in the CHD death rates - less than 0.15% and 0.06% for men and women respectively. The strategies would postpone up to 12 100 deaths over 25 years, comparable to the effect of a 2% reduction in smoking prevalence. The strategies seemed as if they would be more effective if they concentrated on men rather than women, on those over 45 years of age as opposed to all or younger age groups, and on the least active members of the population rather than those already taking some exercise.

Conclusion - The use of computer modelling for simulating physical activity strategies has shown that concentrating these interventions on older sedentary men will produce the greatest health gain, but efforts to encourage smoking cessation may be more effective in terms of years of life saved.

(*J Epidemiol Community Health* 1997;51:144-150)

Health Promotion
Sciences Unit,
Department of Public
Health and Policy,
London School of
Hygiene and Tropical
Medicine, Keppel
Street, London
WC1E 7HT
B Naidoo
M Thorogood
K McPherson

Institute of Social
Medicine, University
of Amsterdam,
Academic Medical
Centre, 1105 AZ
Amsterdam
L J Gunning-Schepers

Correspondence to:
Mr B Naidoo.
Accepted for publication
September 1996

tentially useful in assessing and comparing the relative health gain of alternative intervention strategies. This is a new methodology, and this work should be seen as an early step in attempting to explore the application of these techniques.

Lack of physical activity has been shown to be a strong independent risk factor¹ for death from coronary heart disease (CHD). In a meta-analysis, Berlin and Colditz² calculated a 1.9 fold increased relative risk for CHD mortality associated with a sedentary lifestyle compared with a vigorously active lifestyle. Population surveys have shown that only a small percentage of the British population take enough exercise to protect against CHD.³ Inactivity, then, may be an important cause of CHD mortality. The promotion of physical activity is currently the focus of discussion.⁴ The number of "prescription for exercise" schemes, in which general practice patients are given free or reduced entrance to exercise facilities, is growing rapidly.

The Government's white paper *The Health of the Nation*⁵ in 1992 introduced targets for the reduction in the death rates for CHD. It is not clear how the promotion of physical activity could most effectively contribute to these targets. To contribute to the debate we have modelled the effects of increasing activity in the population, looking at the effects of targeting differing exercise levels, age and gender groups.

This work was undertaken as part of the health gain project, funded jointly by the Health Education Authority and North Thames Regional Health Authority, which aims to provide policy makers with predictions of the effects of changing resource priorities, simulating the effect of shifts in resource allocation using computer modelling.

Methods

CURRENT ACTIVITY LEVELS

Table 1 has been adapted from the Allied Dunbar national fitness survey (ADNFS), and shows the proportion of men and women in England and Wales by age group who are active at different levels. Activity levels were based on 20 minute periods of physical activity in a four week period, and defined as:

Vigorous - 12 or more occasions of activities at 7.5 kcal/minute and above, such as squash, running, football, swimming, tennis, aerobics, and cycling (if out of breath or sweaty).

Moderate - 12 or more occasions of activities between 5 and 7.5 kcal/minute, such as foot-

It is often difficult to evaluate the effectiveness of health promotion interventions by experimental or observational methods since the time scales necessary are too long. An interim solution is to use computer models which will simulate the effects of different interventions within a population, using available data on risk factor prevalence and the attributable risks of disease mortality, and projecting the results over several generations. Such models are po-

Table 1 Prevalence of physical activity by sex, age group, and exercise level

Exercise level	Age groups (%)					
	16-24	25-34	35-44	45-54	55-64	65+
Men:						
Vigorous	28.9	20.4	12.8	8.4	4.1	1.4
Moderate	37.7	41.6	40.8	38.9	29.8	19.6
Light	27.8	30.1	36.5	38.1	36.5	35.9
Sedentary	5.6	7.9	9.9	14.6	29.6	43.1
Women:						
Vigorous	9.7	7.6	4.1	2.9	1.8	0.2
Moderate	37.1	46.5	46.0	37.3	31.8	19.5
Light	44.5	39.4	40.0	46.3	45.3	40.3
Sedentary	8.7	6.5	9.9	13.5	21.1	40.0

ball, swimming, tennis, aerobics and cycling (if not out of breath or sweaty), table tennis, golf, social dancing and exercises (if out of breath or sweaty).

Light - one to 11 occasions of activities at 5 kcal/minute and above, such as table tennis, golf, social dancing and exercises (if not out of breath or sweaty), bowls, fishing, darts and snooker.

Sedentary - no occasions of activities above 5 kcal/minute.

THE STRATEGIES

To evaluate the potential effect of different strategies for physical activity promotion we explored two options representing interventions targeted at sedentary, lightly active, and moderately active people. These strategies were as follows:

Strategy 1 - to encourage those who are either sedentary or lightly active to undertake moderate activity, thus increasing by 25% the proportion of the population aged between 15-64 which is moderately active.

Strategy 2 - to encourage those who are either sedentary, lightly active or moderately active to undertake vigorous activity, thus increasing by 25% the proportion of the population aged between 15 and 64 which is vigorously active.

We have investigated separately the effect of these strategies in men and in women, and in different age groups.

"PREVENT"

*Prevent*⁴ was developed by one of us (LJ Gunning-Schepers) in 1988. It is a cell-based simulation model that can estimate the health benefits for a population of changes in risk factor prevalence due to trends and interventions over a maximum period of 50 years, both in terms of proportional changes in disease specific incidence and in terms of absolute changes in such parameters as disease specific and total mortality.

After the user has specified the risk factor to be modified, the model first calculates the autonomous development of risk factor prevalences due to existing trends. Then the user specifies change in risk factor prevalences after the intervention and the model calculates the development due to the intervention and these trends. Next the model calculates the autonomous development of all other risk factors that share diseases with the intervention risk

factors. Finally the results of the calculations are applied to two populations - one with only the autonomous developments and the other with both the autonomous developments and the intervention effects.

The differences between the two populations are attributed to the intervention, with the output given in terms of total and disease specific mortality (details of the calculations are presented in Appendix 1). It was originally produced to simulate a Dutch population with base year 1985, but we have adapted it to simulate an English and Welsh population with base year 1991.

We have used *Prevent* to simulate proposed changes for the English and Welsh population, modelling the hypotheses of a graded effect for the health benefits of physical activity, using high risk and population strategies to achieve the set strategies.

ADAPTING PREVENT

Prevent does not normally include lack of physical activity as a risk factor, therefore the following data were input for the England and Wales population:

- Physical activity level categories: sedentary, light, moderate, and vigorous,
- Prevalence of physical activity by sex, age groups and activity level,
- Relative risk of CHD death due to lack of physical activity by sex, age groups, and activity level,
- Two time intervals, the first, LAT, giving the time between taking up physical activity and a person's relative risk begins to decrease, and the second, LAG, giving the time between a person's relative risk beginning to decrease and when it reaches its lowest value for the new level of physical activity,
- The remnant relative risk, which is the lowest possible relative risk that an ex-exposed person has after LAT + LAG time has elapsed on taking up a new level of physical activity.

LACK OF PHYSICAL ACTIVITY AND CHD DEATH RISK

The way in which lack of physical activity affects CHD mortality is not fully understood. Although it has been shown to be an independent risk factor; the actual mechanism by which risk of CHD death decreases with increased levels of physical activity is not clear. We used the hypothesis that there is an inverse and graded relationship between CHD risk and physical activity, as proposed by Shaper.⁷

RELATIVE RISKS

The relative risks for CHD mortality due to lack of physical activity were taken from a comprehensive meta-analysis.² No relative risk for light activity was produced in the meta-analysis, so we derived a hypothetical relative

Table 2 Relative risk (RR) of coronary heart disease mortality in relation to exercise level

Exercise levels	RR
Vigorous	1.0
Moderate	1.4
Light	1.7*
Sedentary	1.9

* From interpolation.

risk by interpolation. The relative risks are shown in table 2.

These relative risks are unfortunately not known separately by age or sex, and moreover the definition of exercise levels is not completely clear with respect to duration and calorific output. We have assumed that these levels are similar to those used in the ADNFS data.

The problems of "fitting" available prevalence and relative risk data to the English and Welsh population, and then tailoring these for input into *Prevent* were considerable and entailed making compromises. *Prevent* was not designed to calculate the effect of members of one risk factor exposure group moving into a number of different exposure groups; it was designed solely for modelling movement from an exposed to a non-exposed category. The remnant risks in the model had to be adapted to permit movement between different levels of exposure. An additional problem was that only age group divisions beginning with multiples of five are permitted, so the youngest age for intervention had to be 15 rather than 16 years.

MODEL ASSUMPTIONS

In setting up *Prevent* we have to set certain calculation options and variables, and these translate into a number of assumptions about the way in which an intervention would affect physical activity in the population and the process by which physical activity influences CHD mortality.

We assumed that the intervention started in 1994 and continued for the next 11 years, with the prevalences of the strategies being achieved in 2005, a target year for the *Health of the Nation*.³ The population was simulated for a further 14 years after the end of the intervention.

The mechanism by which physical activity affects CHD mortality is essentially described by the time periods over which a person's risk decreases and the risk it declines to. Within our model we have assumed that on taking up exercise a person's relative risk begins to decrease immediately, and that one year after taking up a new level of exercise a person's relative risk decreases to that of people exercising at that level. We have performed some sensitivity analysis by increasing these time periods when running the model.

In terms of the remnant risk we have assumed that a person's previously less active lifestyle will not continue to have a detrimental effect on their health, and that they will take on the relative risk attributed to their current physical activity level.

As our main interest was to investigate how changing a population's physical activity levels might affect its CHD mortality, we chose to assume that physical activity decreased the risk of CHD death only and did not affect other diseases. In addition, we assumed that physical activity did not affect the other risk factors that *Prevent* includes, such as hypertension, cholesterol, and obesity.

We assumed that the proposed interventions would change an age group's behaviour for the entire simulation period (25 years), so that as cohorts age during the simulation period and move from one age group to the next, some people will take up a new physical activity level which may be at a lower or higher level than the level they achieved in their previous age group.

We have also assumed that any changes in the prevalence of physical activity within the population would be solely as a result of the interventions, and that there would be no background risk factor trends in the population – that is, without an intervention there would be no change over time in rates of physical activity.

Care needs to be taken in choosing either the age group or the cohort option for the calculations in *Prevent*, since the two options can give markedly different results. The age group option should be used when considering a risk factor that is predominately age dependent, such as hypertension. An intervention that causes a behavioural change, such as cigarette smoking cessation, is more likely to affect a birth cohort which retains the change as it ages. We chose to model physical activity as having an age group effect, although we also tested the model with the cohort option to see how this affected the results.

Two scenarios were used to model each strategy to provide lower and upper limits of estimated outcomes. For strategy 1, which aimed to increase the percentage of the population with a moderate level of physical activity, we simulated two scenarios that targeted either the sedentary group, or those already undertaking light activity. Strategy 2, which aimed to increase the number of people undertaking

Table 3 Coronary heart disease mortality per 100 000 for men and for women aged under 95 achieving each strategy

	Year	Strategy 1		Strategy 2	
		Lower	Upper	Lower	Upper
Men:	1994	1382.5	1382.5	1382.5	1382.5
	2019	1381.3	1380.5	1382.1	1381.6
Women:	1994	915	915	915	915
	2019	914.7	914.5	914.9	914.8

Table 4 Modified relative risk of coronary heart disease mortality in relation to exercise level and age group

Exercise levels	Age groups			
	15-44	45-54	55-64	65+
Vigorous	1.0	1.0	1.0	1.0
Moderate	1.4	1.3	1.3	1.3
Light	1.7	1.6	1.5	1.4
Sedentary	1.9	1.8	1.7	1.6

Table 5 Example calculation of potential impact factor (PIF) for the risk factor, lack of physical activity, in men aged 55-64 under strategy 1, using the lower limit of the intervention

Exercise level	Original prevalence (0)	Intervention prevalence (1)	Relative risk		
Vigorous	0.041	0.041	1	PIDR(0)	1.6411
Moderate	0.298	0.391	1.4	PIDR(1)	1.6132
Light	0.365	0.272	1.7		
Sedentary	0.296	0.296	1.9		
Sum	1	1		PIF	0.017

PIDR=proportion incidence density ratio.

vigorous activity, was simulated using two scenarios which assumed that sedentary people would increase their activity to this level or that those already taking moderate exercise would increase their level.

INTERVENTION OUTPUTS

The outputs from the simulated interventions have been produced in terms of:

- Percentage reduction in CHD mortality rate (compared with 1994),
- Actual years of life gained.

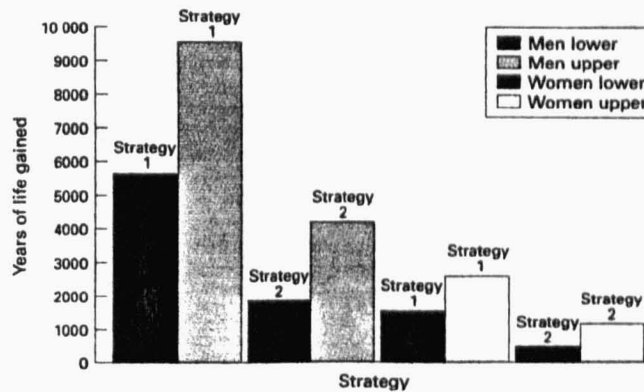

Figure 1 Actual years of life gained for men and for women aged under 95 years and achieving each intervention strategy by the year 2019.

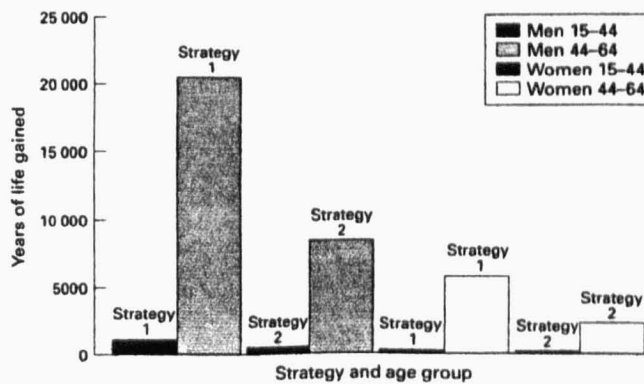

Figure 2 Actual years of life gained for men and women aged under 95 years and achieving each intervention strategy by the year 2019, targeting by age groups.

Results

There would be a very small reduction in the death rate from CHD associated with achievement of each of the two strategies in men and women under 95 years of age, see table 3. This represents a fall of between 0.03% and 0.15% in men and between 0.01% and 0.06% in women, across all age groups combined.

While the proportional reduction in the death rate appears disappointing, the actual years of life gained by the year 2019 are not insubstantial (fig 1). The time trajectory is roughly linear from 1994, showing that the interventions are delaying deaths, although not enough to affect the mortality rate greatly. There are similar trends for both men and women, although the number of deaths postponed for men is about four times greater than for women. For both the upper and lower estimates strategy 1 is the most effective in achieving life years gained. (Appendix 2, tables 6, 7, and 8 gives the data for the figures).

To examine the differing effect of targeting exercise interventions at various age groups, we modelled the life years gained for each of the two strategies making the assumptions that the strategy would concentrate on the older age groups (45-64 years of age) or on the younger age groups (15-44 years of age). Figure 2 shows this comparison in men and women in terms of actual years of life gained, using the mean of the two scenarios simulated. For both men and women, the greatest gain can be achieved by concentrating on the older group. Again strategy 1 was the most effective and, as before, there is less gain achievable in women than in men.

SENSITIVITY ANALYSIS

It is possible that the increased relative risk associated with inactivity is attenuated in older people. If this is true then the model will overestimate the effect of interventions in the elderly. We therefore carried out some sensitivity analysis for the simulations targeting those people aged 45-64 years of age, in which they were given lower relative risks for each level of physical activity (See table 4). This change made only a small difference to the number of deaths postponed, and targeting the older age groups still produced the greatest benefit (figs 3 and 4). Modifying the remnant relative risks did not affect the results for those aged 15-44 years old.

Age group interventions were also simulated, using the cohort option as well as the modified relative risks, to check if this improved the results for those aged 15-44 years old. Under this option the intervention would be responsible for changing people's behaviour for the entire simulation period, in that those people that take up a new physical activity level will continue with this level of activity for 25 years and not revert to a lower level of physical activity. Figures 3 and 4 show that this increased the actual years of life gained when targeting the younger age group, but concentrating on people 45-64 years old still achieved the most health gain.

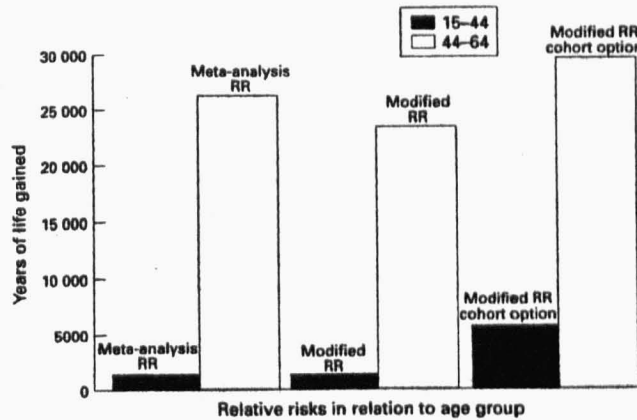

Figure 3 Actual years of life gained for men and women aged under 95 years and achieving strategy 1 by the year 2019, targeting by age groups using modified relative risks and the cohort option.

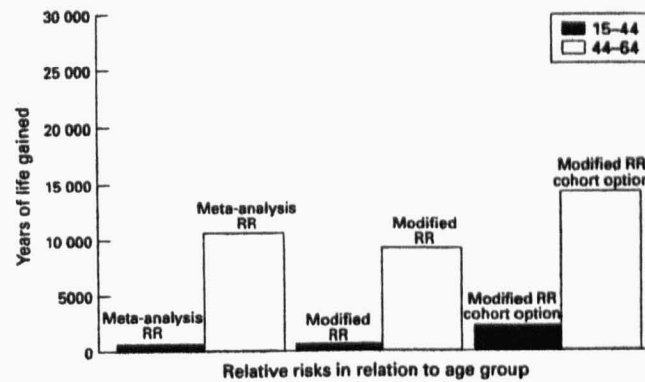

Figure 4 Actual years of life gained for men and for women aged under 95 years and achieving strategy 2 by the year 2019, targeting by age groups using modified relative risks and the cohort option.

Discussion

We have used the *Prevent* cell-based computer simulation model to explore the effect of different strategies which might be undertaken to increase physical activity in the population. This is a new methodology, and much of the work is still of an exploratory nature. None of the strategies modelled appeared to have much effect on predicted CHD mortality, although the most effective strategy seemed to be to encourage sedentary people to undertake moderate activity. If the proportion of the population undertaking moderate activity were increased by 25% as a result of this strategy, then approximately 12 100 years of life would be gained over 25 years. This is very similar to the health gain that could be achieved by a reduction of 2% in the proportion of smokers in the population. The latter might, arguably, be easier to achieve.⁸

The reason for the interventions having little effect on the CHD mortality rate for the population up to the age of 95 is that the majority of deaths from CHD in the population occur

in those over the age of 65, while these interventions concentrate on those under 65. The most effective strategy would achieve a 2.6% reduction for men and a 2% reduction for women in CHD mortality up to 65 years.

The greater effect of strategy 1 as compared with strategy 2 could be because more people receive the intervention, since 39.3% of the population aged between 15 and 64 are moderately active, while only 10.7% are vigorously active. Increasing each category by 25% results in 49.1% of the population in this age group undertaking moderate activity and 13.4% undertaking vigorous activity.

The proportion of the population at risk of CHD in the older age group has a significant impact on the relative effectiveness of the interventions by age group. This is emphasised when using attenuated relative risks for the older age group in the simulation, since the actual years of life gained for this age group still outweighs that for the younger age group, even though the younger age group has higher relative risks.

The use of the cohort option in the simulation showed that the targeting of older age groups was still more effective, in terms of the actual years of life gained over 25 years, than targeting younger cohorts who would retain their new physical activity levels over time. This again may be an implication of the influence of the higher CHD mortality rates among the older age groups in the England and Wales population on the impact of these interventions.

The marked difference between the results for men and women reflects the fact that women have a much lower mortality rate for CHD than men, particularly between the ages of 25 and 64 where the difference in the CHD mortality rate ranges from three to six and a half times lower for women.

There are a number of problems with using *Prevent*, most of which have been discussed when describing the assumptions we have had to make in order to fit physical activity data into the model. These include the fact that the model was initially designed for shifting exposure groups to non-exposure groups and having to use multiples of five for the age group divisions. One of the major drawbacks has been the lack of any estimate of changes in morbidity, especially if physical activity has much bigger effects on the prevalence of non-fatal disease. Work is currently underway to develop a new version,⁹ which takes into account morbidity, and this will greatly increase the applicability of the model.

The *Prevent* model may have underestimated the gain in mortality reduction from increasing physical activity. Since there is no clear understanding of the relationship between physical activity and other established CHD risk factors such as hypertension, hyperlipidaemia, and obesity, we have assumed that physical activity will not affect the prevalence of these risk factors. We have also assumed that increased physical activity will not affect mortality from any other cause of death included in the *Prevent* model. These are cerebrovascular accident, chronic obstructive lung disease, lung cancer,

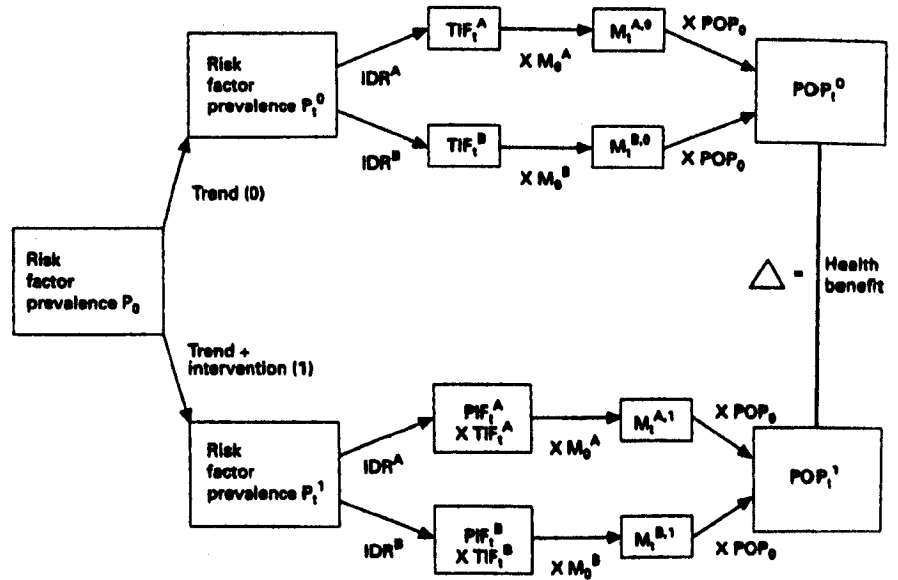

Figure 5 The basic version of the Prevent model.

cirrhosis of the liver, breast cancer, traffic accidents, and accidental falls.

Even if *Prevent* has underestimated the total gain possible from increasing physical activity, the relative gain of different strategies carries an important message. Our work with *Prevent* indicates that the greatest health gain can be achieved by concentrating on sedentary people, on older people, and on men. This may seem a contradiction of Rose's¹⁰ argument that preventive strategies which concentrate on a minority at high risk produce less health gain than strategies which intervene across the whole population, since the minority at high risk contribute a small proportion of adverse events. However, the majority of older men (45 plus) do not undertake even moderate exercise, and older men account for about 67% of coronary death under the age of 75. In this case, then, the most effective strategy is the one which concentrates on that section of the population which is contributing the majority of deaths.

Appendix 1

BASIC METHODOLOGY OF THE PREVENT MODEL^a
Figure 5 illustrates the basic version of the *Prevent* model.

$$PIDR_i^{a,t} = \sum_{i=0}^m \sum_{t=0}^{ID} P_i^{a,t} M_i^{a,t} IDR_i^{a,t}$$

$$TIF_i^{a,t} = \frac{PIDR_i^{a,t} - PIDR_i^{a,t-1}}{PIDR_i^{a,t-1}}$$

$$PIF_i^{a,t} = \frac{PIDR_i^{a,t} - PIDR_i^{a,t-1}}{PIDR_i^{a,t-1}}$$

$$M_i^{a,t} = M_i^{a,t-1} - \sum_{i=1}^m TIF_i^{a,t} M_i^{a,t-1}$$

$$M_i^{a,t} = M_i^{a,t-1} - \sum_{i=1}^m [1 - (TIF_i^{a,t})(1 - PIF_i^{a,t})] M_i^{a,t-1}$$

Where:

- A: index for age.
- t: index for time.
- i: index for ex-exposure level.
- P: proportion.
- ID: total number of ex-exposure levels.
- IDR: incidence density ratio.
- PIF: potential impact fraction - the incidence that is avoided by a preventive intervention as a proportion of the incidence that would have occurred in that population without the intervention.
- TIF: trend impact fraction - the incident cases prevented at a certain moment in time, by an autonomous change in risk factor prevalence, as a proportion of the incident cases that would have occurred at that time in the absence of change.
- LAT: the period between the end of exposure to the risk factor and the first effect on disease specific mortality.

- 1 Powell KE, Thompson PD, Casperson CJ, Kendrick JS. Physical activity and the incidence of coronary heart disease. *Annals New York Academy of Sciences* 1987;8:253-67.
- 2 Berlin JA, Colditz GA. A meta-analysis of physical activity in the prevention of coronary heart disease. *Am J Epidemiol* 1990;132:612-27.
- 3 Sports Council and Health Education Authority. *Allied Dunbar national fitness survey*. London: Sports Council, Department of Health, 1992.
- 4 Health Education Authority. *Moving on - International perspectives on promoting physical activity*. London: HEA, 1994.
- 5 Secretary of State for Health. *The Health of the Nation*. London: HMSO, 1992.
- 6 Gunning-Schepers LJ. The health benefits of prevention, a simulation approach. *Health Policy* 1989;12:1-236.
- 7 Shaper AJ, Wannamethee G. Physical activity and ischaemic heart disease in middle-aged British men. *Br Heart J* 1991; 64:384-94.
- 8 Silagy CA, Fowler GH. Systematically reviewing the effectiveness of pharmacological and non-pharmacological smoking cessation methods. *Journal of Smoking-Related Diseases* 1994;5 (Suppl. 1):295-305.
- 9 Barendregt JJ. From Prevent to NIMPH and back: Some methodologic issues in public health modelling. Proceedings of the European Public Health Association Conference, December 1994, Copenhagen.
- 10 Rose G. *The strategy of preventive medicine*. Oxford: Oxford University Press, 1992.

cn: total number of exposure categories.
 n: index for exposure category.
 r: index for risk factor.
 j = 0, 1: index for trend (0) or intervention population (1).
 s: index for sex.
 z: index for disease.
 M^{AA} : constant overall mortality quotient.
 M^{AA} : adjusted overall mortality quotient.
 M^{AA} : disease specific mortality quotient.

Table 5 exemplifies an intervention on one risk factor for one age group with no background trends for that risk factor. It shows that this intervention will result in a reduction of 1.7% in CHD mortality for men aged 55-64.

Appendix 2
 Tables 6, 7, and 8 below give the data on which figures 2, 3, and 4 are based.

Table 6 Actual years of life gained (absolute numbers) for men and for women aged under 95 achieving each strategy by 2019

	Strategy 1		Strategy 2	
	Lower	Upper	Lower	Upper
Men	5613	9537	1866	4167
Women	1311	2536	301	1129

Table 7 Actual years of life gained (absolute numbers) for men and for women aged under 95 achieving each strategy by 2019, targeting by age groups

	Strategy 1		Strategy 2	
	15-44	45-64	15-44	45-64
Men	968	20 437	401	8238
Women	155	5673	64	2261

Table 8 Actual years of life gained (absolute numbers) for men and for women aged under 95 achieving strategy 1 and Strategy 2 by 2019, targeting by age groups using modified relative risks (RR) and using the cohort option

	Total		Modified RR		Cohort modified RR	
	15-44	45-64	15-44	45-64	15-44	45-64
Strategy 1	1123	26 112	1123	23 283	9373	29 484
Strategy 2	465	10 503	465	9104	2130	14 321

Appendix F - Input Data for the Birmingham, Small Heath and Sutton Coldfield Versions of the Prevent Model

Age	Birmingham		Small Heath		Sutton Coldfield	
	Male	Female	Male	Female	Male	Female
0	7901	7388	979	889	535	503
1	8002	7492	983	906	525	490
2	8033	7529	980	913	522	482
3	8000	7507	970	912	526	479
4	7914	7434	954	903	532	480
5	7782	7319	934	887	540	484
6	7614	7170	909	866	548	491
7	7418	6996	882	841	553	501
8	7203	6805	852	813	555	512
9	6983	6609	822	784	554	525
10	6771	6421	792	754	552	538
11	6583	6253	763	726	552	551
12	6436	6122	737	701	558	564
13	6344	6040	716	681	573	576
14	6316	6014	700	667	593	586
15	6269	5971	680	650	616	597
16	6275	5979	666	637	635	607
17	6505	6188	673	651	649	607
18	7021	6658	708	700	653	594
19	7730	7303	763	771	651	574
20	8511	8014	826	853	647	549
21	9199	8642	879	923	643	528
22	9699	9106	906	960	640	517
23	9921	9330	896	951	636	520
24	9920	9358	858	907	633	534
25	9869	9342	811	853	629	550
26	9808	9315	769	804	624	565
27	9610	9161	727	758	621	579
28	9261	8866	691	719	621	593
29	8803	8466	657	686	622	605
30	8282	8010	622	651	626	621
31	7768	7559	584	612	630	637
32	7312	7151	550	576	629	646
33	6955	6821	523	542	622	647
34	6683	6560	500	512	612	642

Table F.1a - Population structures of Birmingham, Small Heath and Sutton Coldfield by age (0 to 34 years) and sex

Age	Birmingham		Small Heath		Sutton Coldfield	
	Male	Female	Male	Female	Male	Female
35	6409	6291	479	482	598	632
36	6138	6026	459	453	588	625
37	5962	5859	437	429	594	633
38	5906	5816	411	411	623	662
39	5935	5859	385	396	666	703
40	6014	5954	359	384	714	750
41	6074	6024	337	374	755	788
42	6064	6015	319	362	779	807
43	5947	5886	309	349	780	802
44	5752	5671	303	335	763	777
45	5545	5438	300	322	742	748
46	5370	5241	299	311	723	721
47	5213	5075	302	307	697	691
48	5086	4960	312	309	664	659
49	4986	4886	325	318	626	628
50	4888	4821	341	328	585	593
51	4794	4756	357	338	545	559
52	4733	4710	370	345	517	537
53	4713	4685	379	350	506	530
54	4722	4678	386	352	508	535
55	4741	4683	390	354	512	544
56	4759	4695	395	356	513	550
57	4780	4714	399	356	517	555
58	4801	4739	403	354	520	555
59	4819	4768	407	349	524	551
60	4836	4796	410	345	529	549
61	4843	4825	411	340	533	546
62	4822	4862	403	331	528	542
63	4767	4909	386	320	512	533
64	4682	4958	361	306	488	522
65	4585	5009	332	290	461	509
66	4478	5044	305	275	435	497
67	4341	5038	282	264	410	487
68	4171	4980	266	259	387	480
69	3975	4880	254	259	367	474
70	3760	4758	244	259	346	470

Table F.1b - Population structures of Birmingham, Small Heath and Sutton Coldfield by age (35 to 70 years) and sex

Age	Birmingham		Small Heath		Sutton Coldfield	
	Male	Female	Male	Female	Male	Female
71	3543	4633	231	257	324	463
72	3339	4511	218	255	305	454
73	3160	4402	202	251	289	442
74	2997	4297	185	245	277	428
75	2839	4185	169	239	266	412
76	2668	4052	153	233	254	397
77	2475	3896	138	224	239	381
78	2254	3712	123	211	219	363
79	2014	3505	109	195	196	345
80	1774	3292	95	177	173	323
81	1545	3072	82	160	151	302
82	1321	2827	70	146	132	285
83	1106	2552	60	136	118	275
84	904	2258	52	131	107	269
85	748	1996	36	94	86	203
86	613	1759	30	83	71	179
87	484	1496	23	71	56	152
88	378	1248	18	59	44	127
89	286	1036	14	49	33	105
90	218	845	11	40	25	86
91	148	648	7	31	17	66
92	102	486	5	23	12	49
93	72	361	3	17	8	37
94	49	270	2	13	6	28
95+	103	654	5	31	12	67

Table F.1c - Population structures of Birmingham, Small Heath and Sutton Coldfield by age (71 to 95 plus years) and sex

Age	Birmingham		Small Heath		Sutton Coldfield	
	Male	Female	Male	Female	Male	Female
0	1175.23	1009.97	1560.96	1074.27	559.19	634.26
1	59.96	77.38	121.96	88.26	0.00	0.00
2	44.81	37.18	40.80	65.67	38.28	0.00
3	42.49	50.61	123.61	21.93	0.00	0.00
4	20.22	21.52	20.95	22.15	0.00	41.67
5	15.42	27.32	42.82	45.07	0.00	0.00
6	18.39	8.37	43.98	23.08	0.00	0.00
7	18.87	14.29	22.68	0.00	0.00	0.00
8	24.99	11.75	70.38	24.59	0.00	0.00
9	5.73	12.10	0.00	0.00	0.00	0.00
10	20.67	12.46	25.26	53.05	0.00	0.00
11	21.27	12.79	26.21	27.56	0.00	0.00
12	34.18	9.80	27.12	0.00	71.67	0.00
13	47.27	16.56	55.84	0.00	0.00	69.46
14	15.83	26.60	0.00	29.96	0.00	0.00
15	44.66	20.09	88.14	0.00	64.95	0.00
16	38.24	20.07	60.08	31.39	31.47	0.00
17	43.03	9.70	59.44	30.72	30.82	0.00
18	71.19	36.04	0.00	28.58	61.21	0.00
19	67.25	32.86	104.83	25.94	153.52	69.72
20	65.77	29.94	96.76	46.86	61.84	36.43
21	45.65	27.77	45.47	21.67	31.08	113.51
22	72.15	26.35	88.22	104.10	93.75	0.00
23	74.56	32.15	66.94	63.07	62.85	0.00
24	68.53	38.46	116.52	44.07	31.59	0.00
25	101.28	36.39	295.51	23.44	63.59	72.66
26	61.16	27.91	78.01	0.00	32.04	70.83
27	60.34	37.11	82.45	52.76	96.53	0.00
28	77.71	22.56	173.63	0.00	32.21	0.00
29	79.49	37.79	152.02	29.17	128.53	33.03
30	103.79	27.46	128.57	30.73	127.72	0.00
31	72.06	66.13	102.68	97.93	63.50	0.00
32	101.15	69.90	36.33	138.81	31.79	0.00
33	86.23	49.83	152.89	36.87	64.27	30.92
34	104.69	82.29	40.01	117.22	32.67	124.54
35	115.40	108.04	125.06	0.00	100.34	126.56

Table F.2a - Mortality probability per 100,000 in 1 year age groups for Birmingham, Small Heath and Sutton Coldfield by age (0 to 35 years) and sex, 1989-1993

Age	Birmingham		Small Heath		Sutton Coldfield	
	Male	Female	Male	Female	Male	Female
36	127.01	76.31	43.57	0.00	170.00	127.90
37	187.68	109.18	228.75	93.10	134.56	157.81
38	216.48	116.86	388.21	146.03	96.32	30.22
39	205.34	139.85	363.35	201.92	90.07	85.27
40	199.34	127.57	222.75	156.04	55.98	79.97
41	233.52	139.34	296.65	373.98	211.83	126.88
42	224.03	109.66	374.94	55.17	153.99	49.53
43	255.29	156.18	258.80	228.79	102.55	99.72
44	288.19	225.47	197.50	238.19	157.21	205.67
45	349.23	213.09	597.81	310.23	188.45	187.05
46	364.31	282.01	400.95	448.67	110.59	166.31
47	386.75	228.30	396.19	195.47	200.71	202.40
48	408.14	269.78	384.31	451.39	210.73	181.80
49	536.12	253.47	979.26	690.03	350.65	159.16
50	591.58	298.24	817.47	607.61	341.58	235.89
51	685.97	386.17	1115.08	236.67	366.19	392.54
52	673.78	381.45	861.05	519.68	770.06	297.42
53	916.71	430.22	1361.09	171.16	630.07	225.96
54	872.86	588.22	1134.40	791.19	510.91	298.48
55	1032.33	515.43	1172.00	450.66	390.18	367.07
56	1061.90	658.12	958.60	839.37	698.78	615.96
57	1139.97	739.67	1147.26	951.04	501.92	539.39
58	1361.14	702.27	1721.92	788.77	460.04	503.45
59	1499.32	868.61	1416.30	1307.70	836.48	362.05
60	1669.16	896.69	1787.62	923.32	1053.15	545.44
61	1991.33	1006.33	2072.18	1170.90	1305.94	801.94
62	1893.83	1181.80	2352.32	1080.62	1242.61	1065.13
63	2317.96	1299.33	2255.38	1429.18	1704.20	896.18
64	2472.34	1386.02	3431.05	1236.17	1384.53	801.11
65	2723.43	1537.25	3719.78	1914.48	1551.08	898.95
66	2805.18	1928.29	3286.00	3431.22	1733.30	1438.25
67	3614.61	1786.26	3891.02	2096.69	2172.88	1468.62
68	3837.92	2180.99	4845.60	2737.81	3401.62	1325.86
69	4418.32	2469.15	4386.16	2895.94	3640.16	1589.22
70	4578.81	2765.20	5198.63	3194.26	3970.98	1730.99

Table F.2b - Mortality probability per 100,000 in 1 year age groups for Birmingham, Small Heath and Sutton Coldfield by age (36 to 70 years) and sex, 1989-1993

Age	Birmingham		Small Heath		Sutton Coldfield	
	Male	Female	Male	Female	Male	Female
71	4605.25	2582.51	4895.80	3884.77	3758.35	1670.17
72	5271.44	2702.97	6920.69	3769.40	3419.42	2349.37
73	5740.98	2932.49	7061.27	3524.93	4062.56	2588.88
74	6112.86	3367.72	8169.98	2897.94	4867.10	2356.76
75	6364.13	3719.26	7517.96	4097.24	5422.39	3196.84
76	7170.87	4094.99	8370.29	4778.03	4397.20	3512.49
77	7758.45	4373.27	8325.64	5732.20	5939.55	3712.28
78	8527.20	4744.32	9865.13	6523.10	8316.12	4259.40
79	9560.19	5310.94	13339.32	6073.42	9596.77	4869.52
80	9912.49	6159.67	12413.89	9275.54	8958.76	5707.15
81	11391.51	6597.32	12152.06	7250.67	13716.57	5850.32
82	12183.49	7641.40	14527.97	8677.99	12228.94	6838.21
83	12950.24	8495.98	14430.46	10021.85	10742.00	6806.87
84	14698.74	8937.31	15868.31	9059.75	14504.09	7926.16
85	14991.60	9362.27	5993.39	2753.73	13304.20	10344.13
86	15952.62	10715.52	6397.54	3167.64	14165.34	11830.50
87	17103.65	11927.55	6884.93	3541.90	15198.05	13159.87
88	17277.42	13024.29	6958.83	3883.50	15354.09	14361.27
89	19662.69	14455.06	7981.77	4333.39	17499.27	15926.40
90	20661.29	15231.70	8414.82	4579.64	18399.19	16774.95
91	23577.60	17350.89	9696.01	5258.99	21033.67	19086.67
92	25830.06	18873.26	10702.76	5753.84	23074.88	20744.04
93	24629.51	21185.86	10164.28	6516.71	21986.22	23256.45
94	29194.57	24195.71	12235.28	7530.30	26134.36	26516.84
95+	25699.53	22780.68	10644.00	7050.82	22956.44	24985.35

Table F.2c - Mortality probability per 100,000 in 1 year age groups for Birmingham, Small Heath and Sutton Coldfield by age (71 to 95 plus years) and sex, 1989-1993

Year	Birmingham	Sutton Coldfield	Small Heath
1991	8180	488	1147
1992	8188	463	1097
1993	8150	418	1071
1994	8078	432	1109
1995	7970	423	1066
1996	7829	434	1142
1997	7676	429	1128
1998	7527	422	1110
1999	7389	413	1086
2000	7268	405	1064
2001	7163	396	1043
2002	7072	389	1023
2003	7006	382	1005
2004	6956	376	989
2005	6930	371	976
2006	6924	367	966
2007	6932	365	959
2008	6954	363	955
2009	6983	362	954
2010	7021	361	949
2011	7065	360	947
2012	7108	360	946
2013	7149	360	946
2014	7181	360	946
2015	7205	355	935
2016	7205	351	923
2017	7205	346	911
2018-41	7205	341	897

Table F.3 - Birth projections for Birmingham, Small Heath and Sutton Coldfield, 1991-2041

Age	Birmingham		Sutton Coldfield		Small Heath	
	Male	Female	Male	Female	Male	Female
0	72.0	78.1	75.6	80.4	69.8	76.5
1	71.9	77.9	75.2	80.0	69.8	76.3
2	70.9	77.0	74.2	79.0	68.9	75.4
3	69.9	76.0	73.2	78.0	68.0	74.5
4	69.0	75.0	72.2	77.0	67.0	73.5
5	68.0	74.0	71.2	76.0	66.1	72.6
6	67.0	73.1	70.2	75.0	65.1	71.6
7	66.0	72.1	69.2	74.0	64.1	70.6
8	65.0	71.1	68.2	73.0	63.1	69.7
9	64.0	70.1	67.2	72.0	62.1	68.7
10	63.0	69.1	66.2	71.0	61.1	67.7
11	62.0	68.1	65.2	70.0	60.1	66.7
12	61.0	67.1	64.2	69.0	59.1	65.7
13	60.1	66.1	63.2	68.1	58.2	64.8
14	59.1	65.1	62.2	67.1	57.2	63.8
15	58.1	64.1	61.2	66.1	56.2	62.8
16	57.1	63.2	60.2	65.1	55.2	61.8
17	56.2	62.2	59.3	64.1	54.3	60.8
18	55.2	61.2	58.3	63.1	53.3	59.9
19	54.2	60.2	57.4	62.1	52.4	58.9
20	53.3	59.2	56.4	61.1	51.4	57.9
21	52.3	58.2	55.4	60.1	50.4	56.9
22	51.3	57.3	54.5	59.1	49.5	56.0
23	50.3	56.3	53.5	58.2	48.5	55.0
24	49.4	55.3	52.6	57.2	47.6	54.1
25	48.4	54.3	51.6	56.2	46.6	53.1
26	47.5	53.3	50.6	55.2	45.7	52.1
27	46.5	52.3	49.7	54.2	44.8	51.1
28	45.5	51.4	48.7	53.3	43.8	50.1
29	44.6	50.4	47.8	52.3	42.9	49.1
30	43.6	49.4	46.8	51.3	42.0	48.1
31	42.6	48.4	45.8	50.3	41.0	47.1
32	41.7	47.4	44.8	49.3	40.0	46.2
33	40.7	46.5	43.9	48.4	39.1	45.2
34	39.7	45.5	42.9	47.4	38.1	44.3
35	38.8	44.5	41.9	46.4	37.1	43.3

Table F.4a - Life expectancy in 1 year age groups for Birmingham, Small Heath and Sutton Coldfield by age (0 to 35 years) and sex, 1990-1992

Age	Birmingham		Sutton Coldfield		Small Heath	
	Male	Female	Male	Female	Male	Female
36	37.8	43.6	40.9	45.5	36.2	42.3
37	36.9	42.6	40.0	44.5	35.3	41.4
38	36.0	41.6	39.0	43.6	34.3	40.4
39	35.0	40.7	38.1	42.6	33.4	39.5
40	34.1	39.8	37.1	41.7	32.5	38.5
41	33.2	38.8	36.2	40.7	31.6	37.6
42	32.3	37.9	35.2	39.8	30.7	36.7
43	31.4	36.9	34.3	38.8	29.7	35.7
44	30.5	36.0	33.3	37.9	28.8	34.8
45	29.5	35.1	32.4	36.9	27.9	33.9
46	28.6	34.1	31.5	36.0	27.1	33.0
47	27.8	33.2	30.5	35.0	26.3	32.1
48	26.9	32.3	29.6	34.1	25.4	31.3
49	26.0	31.4	28.6	33.1	24.6	30.4
50	25.1	30.5	27.7	32.2	23.8	29.5
51	24.3	29.6	26.8	31.3	23.0	28.6
52	23.4	28.7	26.0	30.4	22.2	27.7
53	22.6	27.8	25.1	29.4	21.5	26.8
54	21.8	26.9	24.3	28.5	20.7	25.9
55	21.0	26.1	23.4	27.6	19.9	25.0
56	20.2	25.2	22.5	26.7	19.1	24.2
57	19.4	24.3	21.6	25.8	18.3	23.4
58	18.6	23.5	20.7	25.0	17.5	22.6
59	17.9	22.7	19.8	24.1	16.7	21.8
60	17.1	21.9	18.9	23.2	15.9	21.0
61	16.4	21.1	18.2	22.4	15.2	20.2
62	15.7	20.3	17.4	21.5	14.5	19.5
63	15.0	19.5	16.7	20.7	13.9	18.7
64	14.4	18.7	15.9	19.8	13.2	18.0
65	13.7	18.0	15.2	19.0	12.5	17.2
66	13.1	17.3	14.5	18.2	12.0	16.6
67	12.4	16.6	13.8	17.4	11.4	15.9
68	11.8	15.9	13.2	16.7	10.9	15.3
69	11.3	15.2	12.5	15.9	10.3	14.6
70	10.8	14.6	11.8	15.1	9.8	14.0

Table F.4b - Life expectancy in 1 year age groups for Birmingham, Small Heath and Sutton Coldfield by age (36 to 70 years) and sex, 1990-1992

Age	Birmingham		Sutton Coldfield		Small Heath	
	Male	Female	Male	Female	Male	Female
71	10.4	14.0	11.2	14.4	9.3	13.4
72	9.8	13.4	10.7	13.7	8.9	12.8
73	9.3	12.8	10.1	13.0	8.4	12.2
74	8.8	12.1	9.6	12.3	8.0	11.6
75	8.3	11.5	9.0	11.6	7.5	11.0
76	7.9	10.9	8.5	11.0	7.1	10.5
77	7.4	10.4	8.1	10.4	6.7	10.0
78	7.0	9.8	7.6	9.9	6.3	9.4
79	6.7	9.3	7.2	9.3	5.9	8.9
80	6.3	8.8	6.7	8.7	5.5	8.4
81	6.0	8.3	6.5	8.2	5.2	8.1
82	5.6	7.8	6.3	7.7	5.0	7.8
83	5.4	7.4	6.1	7.2	4.7	7.4
84	5.1	7.1	5.9	6.7	4.5	7.1
85+	5.0	6.7	5.7	6.2	4.2	6.8

Table F.4c - Life expectancy in 1 year age groups for Birmingham, Small Heath and Sutton Coldfield by age (71 to 85 plus years) and sex, 1990-1992

Alcohol	Male	Male	Male	Female	Female	Female
Age Groups	< 10 units	11 - 21 units	> 21 units	< 7 units	7 - 14 units	> 14 units
15 - 24	63.6	29.1	7.3	50.9	41.4	7.7
25 - 34	46.6	42.1	11.3	48.0	47.3	4.7
35 - 44	35.9	49.5	14.6	51.9	43.1	5.0
45 - 54	31.1	53.7	15.2	62.1	33.7	4.2
55 - 64	34.0	53.4	12.6	73.7	23.1	3.2
65+	38.7	50.6	10.8	82.5	14.3	3.2

Table F.5 - Prevalence of alcohol consumption in the Birmingham population

Male	Sedentary	Light Activity	Moderate Activity	Vigorous Activity
15 - 24	14.1	15.4	34.6	35.9
25 - 34	15.9	20.3	29.5	34.2
35 - 44	19.3	28.9	24.6	27.3
45 - 54	23.6	30.6	23.6	22.3
55 - 64	30.6	26.4	20.8	22.3
65+	36.3	24.6	18	21.1
Female	Sedentary	Light Activity	Moderate Activity	Vigorous Activity
15 - 24	18.9	25.3	28.4	27.4
25 - 34	19.8	28.2	27.2	24.8
35 - 44	22.2	32.4	25.5	20.0
45 - 54	23.8	32.9	23.1	20.1
55 - 64	29.4	31.2	19.3	20.1
65+	39.8	27.1	16.6	16.5

Table F.6 - Prevalence of physical activity levels in the Birmingham population

Male	Never Smoked	Ex-Smokers	1 - 9 cigarettes	10 - 20 cigarettes	20+ cigarettes
15 - 24	65.3	6.0	11.1	14.1	3.5
25 - 34	51.9	17.0	6.3	10.7	14.1
35 - 44	41.7	28.6	7.1	8.8	13.8
45 - 54	32.9	36.8	5.1	7.6	17.7
55 - 64	24.2	50.2	3.1	8.8	13.7
65+	21.1	62.7	4.9	6.0	5.3
Female	Never Smoked	Ex-Smokers	1 - 9 cigarettes	10 - 20 cigarettes	20+ cigarettes
15 - 24	63.3	13	7.7	10.1	5.8
25 - 34	56.8	13.7	9.8	11.4	8.3
35 - 44	49.4	18.4	7.1	11.6	13.5
45 - 54	46.4	27.7	5.0	7.6	13.3
55 - 64	52.8	24.3	6.9	11.0	5.0
65+	57.0	28.9	6.7	4.6	2.8

Table F.7 - Prevalence of cigarette smoking in the Birmingham population

Cholesterol	Male			Female		
	Normal	Mild	Severe	Normal	Mild	Severe
15 - 24	97.5	2.5	0.0	93	5.3	1.8
25 - 34	83.3	12.1	4.5	87.4	12.1	0.5
35 - 44	73.3	20.7	6	88.2	10	1.8
45 - 54	66.0	25.1	8.9	59.4	33.3	7.3
55 - 64	62.8	29.3	7.9	50.0	37.3	12.7
65+	67.0	28.0	4.9	43.2	36.6	20.2

Table F.8 - Prevalence of hypercholesterolaemia levels in the Birmingham population

Hypertension	Male			Female		
	Normal	Mild	Severe	Normal	Mild	Severe
15 - 24	96.0	2.9	1.1	99.4	0.6	0.0
25 - 34	92.8	4.7	2.5	97.2	0.8	2.0
35 - 44	83.2	7.8	9.0	92.3	5.5	2.2
45 - 54	68.8	15.0	16.3	86.0	6.0	8.1
55 - 64	68.4	11.8	19.8	84.9	7.6	7.6
65+	66.7	13.1	20.3	73.5	11.0	15.5

Table F.9 - Prevalence of hypertension levels in the Birmingham population

Hypertension	Male			Female		
	Untreated	20% Screening	40% Screening	Untreated	20% Screening	40% Screening
15 - 24	3.6	0.7	1.4	0.0	0.0	0.0
25 - 34	5.3	1.1	2.1	2.5	0.5	1.0
35 - 44	10.7	2.1	4.3	3.5	0.7	1.4
45 - 54	14.5	2.9	5.8	9.5	1.9	3.8
55 - 64	23.3	4.7	9.3	15.8	3.1	6.3
65+	37.3	7.5	14.9	34.6	6.9	13.8

Table F.10 - Prevalence of untreated hypertensives in the Birmingham population

Alcohol	Male	Male	Male	Female	Female	Female
Age Groups	< 10 units	11 - 21 units	> 21 units	< 7 units	7 - 14 units	> 14 units
15 - 24	75.7	24.3	0.0	75.4	24.6	0.0
25 - 34	75.7	21.0	3.3	66.2	33.8	0.0
35 - 44	55.6	16.0	28.3	72.4	23.4	4.2
45 - 54	65.6	9.4	25.0	82.3	13.5	4.2
55 - 64	87.5	12.5	0.0	90.6	9.4	0.0
65+	72.1	27.9	0.0	92.3	7.7	0.0

Table F.11 - Prevalence of alcohol consumption in the Small Heath population

Alcohol	Male	Male	Male	Female	Female	Female
Age Groups	< 10 units	11 - 21 units	> 21 units	< 7 units	7 - 14 units	> 14 units
15 - 24	16.3	45.5	38.2	34.3	41.4	24.3
25 - 34	21.5	49.8	28.6	49.3	46.9	3.8
35 - 44	26.1	55.1	18.9	45.7	51.9	2.4
45 - 54	30.5	49.1	20.4	56.7	41.1	2.2
55 - 64	44.6	40.7	14.6	72.8	25.2	2.0
65+	55.7	37.5	6.8	84.6	12.5	2.9

Table F.12 - Prevalence of alcohol consumption in the Sutton Coldfield population

Male	Sedentary	Light Activity	Moderate Activity	Vigorous Activity
15 - 24	18.8	17.6	44.9	18.8
25 - 34	27.0	33.5	24.0	15.5
35 - 44	32.1	30.5	20.7	16.8
45 - 54	33.3	10.7	23.0	33.0
55 - 64	34.8	18.5	20.6	26.1
65+	39.6	22.3	22.5	15.6
Female	Sedentary	Light Activity	Moderate Activity	Vigorous Activity
15 - 24	21.2	26.6	34.0	18.2
25 - 34	25.9	22.8	25.6	25.7
35 - 44	40.9	19.1	15.6	24.3
45 - 54	54.9	18.9	11.5	14.7
55 - 64	66.5	14.2	12.1	7.1
65+	75.7	9.7	9.7	4.9

Table F.13 - Prevalence of physical activity levels in the Small Heath population

Male	Sedentary	Light Activity	Moderate Activity	Vigorous Activity
15 - 24	9.1	12.7	41.4	36.7
25 - 34	13.4	18.3	32.7	35.6
35 - 44	20.8	31.7	23.1	24.4
45 - 54	24.0	35.6	23.5	16.8
55 - 64	30.5	27.1	21.4	21.0
65+	44.0	17.2	17.5	21.3
Female	Sedentary	Light Activity	Moderate Activity	Vigorous Activity
15 - 24	9.6	31.8	23.9	34.6
25 - 34	22.6	35.8	22.6	19.1
35 - 44	23.9	32.6	22.6	20.9
45 - 54	22.9	33.5	20.8	22.8
55 - 64	30.9	33.2	19.2	16.6
65+	48.4	25.9	14.0	11.8

Table F.14 - Prevalence of physical activity levels in the Sutton Coldfield population

Male	Never Smoked	Ex-Smokers	1 - 9 cigarettes	10 - 20 cigarettes	20+ cigarettes
15 - 24	61.8	12.9	4.9	12.7	7.7
25 - 34	50.9	19.8	18.2	9.4	1.6
35 - 44	31.1	24.5	27.7	11.8	4.9
45 - 54	22.0	24.6	19.3	19.3	14.8
55 - 64	27.4	34.9	18.3	9.7	9.7
65+	26.0	39.7	13.4	17.8	3.1
Female	Never Smoked	Ex-Smokers	1 - 9 cigarettes	10 - 20 cigarettes	20+ cigarettes
15 - 24	77.0	3.7	2.4	16.1	0.8
25 - 34	63.3	8.7	6.6	18.7	2.7
35 - 44	56.5	18.0	6.0	18.1	1.4
45 - 54	59.1	18.8	5.9	16.2	0.0
55 - 64	60.1	10.8	16.3	12.9	0.0
65+	50.8	22.0	18.2	9.1	0.0

Table F.15 - Prevalence of cigarette smoking in the Small Heath population

Male	Never Smoked	Ex-Smokers	1 - 9 cigarettes	10 - 20 cigarettes	20+ cigarettes
15 - 24	47.2	13.4	26.2	11.7	1.5
25 - 34	64.3	11.5	12.3	8.6	3.4
35 - 44	54.3	24.7	10.2	7.2	3.6
45 - 54	34.7	40.9	12.1	8.6	3.7
55 - 64	26.5	55.0	7.9	9.2	1.5
65+	20.4	70.2	6.2	2.7	0.5
Female	Never Smoked	Ex-Smokers	1 - 9 cigarettes	10 - 20 cigarettes	20+ cigarettes
15 - 24	41.9	22.6	25.2	10.4	0.0
25 - 34	60.8	19.7	8.9	7.5	3.0
35 - 44	62.3	23.5	5.0	7.0	2.2
45 - 54	58.9	29.1	5.7	5.1	1.2
55 - 64	48.5	37.8	6.9	4.1	2.8
65+	48.8	38.0	8.2	3.8	1.3

Table F.16 - Prevalence of cigarette smoking in the Sutton Coldfield population

Age Groups	Lung Cancer		COLD		IHD		CVA	
	Males	Females	Males	Females	Males	Females	Males	Females
0-4	0.000000	0.000000	0.000000	0.000000	0.000000	0.000000	0.000015	0.000011
5-9	0.000000	0.000000	0.000000	0.000000	0.000000	0.000000	0.000005	0.000000
10-14	0.000000	0.000000	0.000000	0.000000	0.000000	0.000000	0.000000	0.000006
15-19	0.000000	0.000000	0.000000	0.000000	0.000000	0.000000	0.000012	0.000006
20-24	0.000004	0.000000	0.000000	0.000000	0.000017	0.000000	0.000013	0.000013
25-29	0.000000	0.000000	0.000000	0.000000	0.000017	0.000004	0.000017	0.000022
30-34	0.000011	0.000006	0.000000	0.000000	0.000032	0.000006	0.000011	0.000011
35-39	0.000040	0.000013	0.000000	0.000000	0.000237	0.000047	0.000033	0.000080
40-44	0.000141	0.000061	0.000000	0.000014	0.000590	0.000095	0.000107	0.000115
45-49	0.000313	0.000141	0.000015	0.000008	0.001305	0.000234	0.000191	0.000227
50-54	0.000855	0.000288	0.000067	0.000068	0.002784	0.000567	0.000436	0.000271
55-59	0.001397	0.000517	0.000251	0.000212	0.004393	0.001466	0.000678	0.000517
60-64	0.002422	0.001027	0.000668	0.000312	0.007457	0.002678	0.001403	0.000945
65-69	0.004845	0.001555	0.001494	0.000938	0.011963	0.005082	0.002348	0.001667
70-74	0.005786	0.001823	0.003155	0.001274	0.017083	0.008159	0.004762	0.003133
75-79	0.006073	0.001705	0.004980	0.001426	0.023690	0.012362	0.008980	0.006718
80-84	0.007880	0.001929	0.007579	0.001729	0.034105	0.020714	0.014105	0.013514
85-90	0.007400	0.001020	0.010437	0.002640	0.044498	0.028866	0.021851	0.021342
90-94	0.005608	0.000832	0.013503	0.003621	0.058896	0.041925	0.032798	0.035038
95+	0.003268	0.000835	0.014254	0.004053	0.069096	0.050799	0.035781	0.043263

Table F.17a - Disease specific mortality probability in 1 year age groups for Birmingham by age and sex, 1989-1993

Age Groups	Cirrhosis		Accidental Falls		Traffic Accidents		Breast Cancer
	Males	Females	Males	Females	Males	Females	Females
0-4	0.000005	0.000000	0.000000	0.000000	0.000010	0.000016	0.000000
5-9	0.000000	0.000000	0.000000	0.000000	0.000032	0.000000	0.000000
10-14	0.000000	0.000000	0.000012	0.000006	0.000025	0.000026	0.000000
15-19	0.000000	0.000000	0.000012	0.000000	0.000077	0.000025	0.000000
20-24	0.000004	0.000000	0.000021	0.000004	0.000063	0.000036	0.000000
25-29	0.000004	0.000004	0.000017	0.000000	0.000046	0.000000	0.000022
30-34	0.000027	0.000011	0.000022	0.000000	0.000043	0.000000	0.000072
35-39	0.000079	0.000054	0.000020	0.000007	0.000086	0.000007	0.000161
40-44	0.000121	0.000068	0.000013	0.000020	0.000040	0.000000	0.000237
45-49	0.000176	0.000102	0.000038	0.000016	0.000053	0.000039	0.000516
50-54	0.000252	0.000101	0.000084	0.000017	0.000050	0.000008	0.000710
55-59	0.000167	0.000085	0.000042	0.000017	0.000017	0.000051	0.000720
60-64	0.000167	0.000107	0.000092	0.000041	0.000050	0.000025	0.001076
65-69	0.000204	0.000152	0.000084	0.000152	0.000084	0.000048	0.001283
70-74	0.000167	0.000097	0.000179	0.000142	0.000131	0.000071	0.001327
75-79	0.000261	0.000176	0.000294	0.000341	0.000147	0.000083	0.001798
80-84	0.000120	0.000186	0.000902	0.000986	0.000241	0.000214	0.002471
85-90	0.000228	0.000079	0.002099	0.001958	0.000134	0.000131	0.002867
90-94	0.000049	0.000066	0.003219	0.003956	0.000107	0.000077	0.003952
95+	0.000000	0.000048	0.004277	0.005985	0.000000	0.000022	0.005012

Table F.17b – Disease specific mortality probability in 1 year age groups for Birmingham by age and sex, 1989-1993

Age Groups	Lung Cancer		COLD		IHD		CVA	
	Males	Females	Males	Females	Males	Females	Males	Females
0-4	0.000000	0.000000	0.000000	0.000000	0.000000	0.000000	0.000000	0.000044
5-9	0.000000	0.000000	0.000000	0.000000	0.000000	0.000000	0.000000	0.000000
10-14	0.000000	0.000000	0.000000	0.000000	0.000000	0.000000	0.000000	0.000000
15-19	0.000000	0.000000	0.000000	0.000000	0.000000	0.000000	0.000000	0.000000
20-24	0.000004	0.000000	0.000000	0.000000	0.000000	0.000000	0.000046	0.000000
25-29	0.000000	0.000000	0.000000	0.000000	0.000055	0.000000	0.000000	0.000052
30-34	0.000000	0.000000	0.000000	0.000000	0.000000	0.000069	0.000000	0.000069
35-39	0.000000	0.000000	0.000000	0.000000	0.000461	0.000000	0.000092	0.000092
40-44	0.000123	0.000000	0.000000	0.000000	0.000738	0.000332	0.000123	0.000222
45-49	0.000520	0.000000	0.000000	0.000000	0.001951	0.000893	0.000520	0.000766
50-54	0.000873	0.000350	0.000109	0.000000	0.004255	0.000817	0.000546	0.000117
55-59	0.001505	0.000791	0.000401	0.000000	0.004014	0.002261	0.000702	0.001357
60-64	0.002740	0.001706	0.000507	0.000244	0.007813	0.001950	0.002131	0.001097
65-69	0.004583	0.001782	0.001250	0.000742	0.012778	0.006978	0.002778	0.002079
70-74	0.006296	0.002526	0.004630	0.001105	0.016481	0.009313	0.008704	0.003157
75-79	0.006926	0.002725	0.006061	0.001998	0.024820	0.015259	0.010390	0.007629
80-84	0.015000	0.002136	0.012778	0.003738	0.036667	0.020828	0.015556	0.017089
85-90	0.009635	0.001664	0.016950	0.005252	0.045514	0.025846	0.020875	0.019043
90-94	0.007302	0.001357	0.021927	0.007203	0.060241	0.037539	0.031332	0.031264
95+	0.004248	0.001362	0.023145	0.008062	0.070674	0.045484	0.034182	0.038603

Table F.18a – Disease specific mortality probability in 1 year age groups for Small Heath by age and sex, 1989-1993

Age Groups	Cirrhosis		Accidental Falls		Traffic Accidents		Breast Cancer
	Males	Females	Males	Females	Males	Females	Females
0-4	0.000000	0.000000	0.000000	0.000000	0.000000	0.000000	0.000000
5-9	0.000000	0.000000	0.000000	0.000000	0.000136	0.000000	0.000000
10-14	0.000000	0.000000	0.000000	0.000000	0.000000	0.000057	0.000000
15-19	0.000000	0.000000	0.000057	0.000000	0.000000	0.000000	0.000000
20-24	0.000000	0.000000	0.000046	0.000000	0.000046	0.000044	0.000000
25-29	0.000000	0.000000	0.000000	0.000000	0.000055	0.000000	0.000105
30-34	0.000000	0.000069	0.000000	0.000000	0.000072	0.000000	0.000069
35-39	0.000184	0.000092	0.000092	0.000000	0.000184	0.000000	0.000000
40-44	0.000123	0.000111	0.000000	0.000000	0.000123	0.000000	0.000443
45-49	0.000390	0.000128	0.000000	0.000000	0.000000	0.000000	0.000511
50-54	0.000873	0.000000	0.000109	0.000000	0.000109	0.000000	0.000583
55-59	0.000201	0.000226	0.000000	0.000000	0.000000	0.000113	0.000339
60-64	0.000203	0.000122	0.000101	0.000122	0.000000	0.000000	0.000731
65-69	0.000139	0.000297	0.000000	0.000297	0.000000	0.000297	0.001633
70-74	0.000556	0.000158	0.000000	0.000000	0.000185	0.000000	0.001894
75-79	0.000289	0.000000	0.000577	0.000000	0.000577	0.000182	0.001635
80-84	0.000556	0.000267	0.001111	0.000534	0.000000	0.000000	0.002937
85-90	0.000000	0.000000	0.002281	0.002006	0.000000	0.000000	0.002419
90-94	0.000000	0.000000	0.003497	0.004052	0.000000	0.000000	0.003335
95+	0.000000	0.000000	0.004648	0.006131	0.000000	0.000000	0.004230

Table F.18b – Disease specific mortality probability in 1 year age groups for Small Heath by age and sex, 1989-1993

Age Groups	Lung Cancer		COLD		IHD		CVA	
	Males	Females	Males	Females	Males	Females	Males	Females
0-4	0.000000	0.000000	0.000000	0.000000	0.000000	0.000000	0.000000	0.000000
5-9	0.000000	0.000000	0.000000	0.000000	0.000000	0.000000	0.000000	0.000000
10-14	0.000000	0.000000	0.000000	0.000000	0.000000	0.000000	0.000000	0.000000
15-19	0.000000	0.000000	0.000000	0.000000	0.000000	0.000000	0.000000	0.000000
20-24	0.000000	0.000000	0.000000	0.000000	0.000000	0.000000	0.000000	0.000000
25-29	0.000000	0.000000	0.000000	0.000000	0.000000	0.000000	0.000064	0.000069
30-34	0.000000	0.000000	0.000000	0.000000	0.000064	0.000000	0.000000	0.000000
35-39	0.000000	0.000000	0.000000	0.000000	0.000196	0.000000	0.000000	0.000061
40-44	0.000053	0.000000	0.000000	0.000000	0.000422	0.000000	0.000053	0.000051
45-49	0.000174	0.000000	0.000000	0.000000	0.000695	0.000232	0.000058	0.000000
50-54	0.000601	0.000000	0.000000	0.000000	0.001954	0.000073	0.000301	0.000218
55-59	0.000541	0.000073	0.000000	0.000000	0.002243	0.000799	0.000309	0.000073
60-64	0.001390	0.000966	0.000077	0.000000	0.004712	0.001412	0.000541	0.000520
65-69	0.003691	0.000572	0.000874	0.000163	0.008159	0.003433	0.001651	0.001389
70-74	0.003636	0.001241	0.002208	0.000620	0.014156	0.004608	0.003636	0.002304
75-79	0.003581	0.001686	0.002387	0.000843	0.021654	0.009905	0.006650	0.006428
80-84	0.005580	0.002062	0.004993	0.001924	0.040822	0.018557	0.014391	0.011546
85-90	0.007516	0.000963	0.006103	0.002757	0.042262	0.028981	0.019485	0.026011
90-94	0.005696	0.000786	0.007895	0.003781	0.055936	0.042093	0.029247	0.042703
95+	0.003314	0.000789	0.008333	0.004232	0.065623	0.051002	0.031907	0.052278

Table F.19a – Disease specific mortality probability in 1 year age groups for Sutton Coldfield by age and sex, 1989-1993

Age Groups	Cirrhosis		Accidental Falls		Traffic Accidents		Breast Cancer
	Males	Females	Males	Females	Males	Females	Females
0-4	0.000000	0.000000	0.000000	0.000000	0.000000	0.000000	0.000000
5-9	0.000000	0.000000	0.000000	0.000000	0.000000	0.000000	0.000000
10-14	0.000000	0.000000	0.000000	0.000000	0.000000	0.000071	0.000000
15-19	0.000000	0.000000	0.000000	0.000000	0.000125	0.000000	0.000000
20-24	0.000063	0.000000	0.000000	0.000000	0.000125	0.000000	0.000000
25-29	0.000000	0.000000	0.000000	0.000000	0.000000	0.000000	0.000000
30-34	0.000000	0.000000	0.000000	0.000000	0.000128	0.000000	0.000000
35-39	0.000000	0.000000	0.000000	0.000000	0.000065	0.000000	0.000123
40-44	0.000053	0.000000	0.000000	0.000000	0.000000	0.000000	0.000255
45-49	0.000058	0.000058	0.000058	0.000058	0.000000	0.000058	0.000290
50-54	0.000075	0.000000	0.000000	0.000000	0.000075	0.000000	0.001089
55-59	0.000077	0.000145	0.000077	0.000000	0.000000	0.000000	0.000653
60-64	0.000154	0.000074	0.000000	0.000000	0.000000	0.000000	0.001263
65-69	0.000291	0.000000	0.000000	0.000082	0.000000	0.000000	0.000736
70-74	0.000390	0.000000	0.000260	0.000000	0.000130	0.000000	0.001506
75-79	0.000000	0.000211	0.000341	0.000632	0.000000	0.000000	0.002107
80-84	0.000000	0.000000	0.000881	0.000687	0.000294	0.000137	0.002337
85-90	0.000000	0.000000	0.000000	0.001460	0.000000	0.000214	0.003362
90-94	0.000000	0.000000	0.000000	0.002949	0.000000	0.000125	0.004634
95+	0.000000	0.000000	0.000000	0.004462	0.000000	0.000036	0.005877

Table F.19b – Disease specific mortality probability in 1 year age groups for Sutton Coldfield by age and sex, 1989-1993

Appendix G - Biomed II Project: Smoking Interventions Modelling Paper (Baan 1999)

ESTIMATES OF SEVERAL ANTI-TOBACCO POLICIES IN FOUR EUROPEAN COUNTRIES

4.1 INTRODUCTION

The health benefit of tobacco control measures in different European countries is not easy to predict. It depends on at least interrelated operating factors: size of the population and its age-structure, the history of tobacco-control policy and mortality from ischaemic heart disease and lung cancer. All these factors may vary more or less between the countries.

A computer simulation model, such as PREVENT 2.8, which has these country specific data as input, can help in assessing the health gain of anti-tobacco policies in different countries.

Aim of this chapter is to illustrate with PREVENT 2.8 the differential effect of the same anti-tobacco measure in four European countries. The following policies will be studied:

- an absolute price-increase of tobacco products with one Euro: 'the one-Euro plus scenario'
- a proportional price increase of tobacco products with 10%: 'the 10%-plus scenario'
- A hypothetical measure to set prices in all four countries to the same level as found in Norway in 1995, i.e. on 4.84 Euro: 'Norway price scenario'
- a maximum advertising restriction policy, including health warnings on cigarette packets, and a ban in each of the following media: cinema, billboards, newspapers, magazines, points of sale, sponsorships, radio, television: 'advertising ban scenario'

We restricted ourselves to price- and advertising policies, as these are relatively well defined. Health education is also an important anti-tobacco instrument, but is more difficult to make operational at a common European level since these is often tailored to the local situation. The effect of other interventions on prevalence of smoking, i.e. protection of non-smokers, or sales restriction for youngsters, could not be assessed quantitatively.

4.2 METHOD

PREVENT 2.8 is described in chapter 2 of this report, the data-input for the four country models used for the analysis, are described in chapter 3. The first three scenarios are based upon a price intervention, the last scenario is based upon tobacco advertising restrictions. For all scenarios we have to estimate the effect on the prevalence of smoking, as this latest is the variable which is input in PREVENT 2.8. Below we first explain how the effect of increasing the price of a 20-cigarette packet on the prevalence of smoking is estimated for the three scenarios on the price intervention. Next, the translation of a restriction in tobacco advertisement in decreasing prevalence of smoking is discussed.

From price increase to prevalence decrease: scenario 1-3

To assess the effect of a price increase in PREVENT 2.8, the effect of price elasticity on the prevalence of smoking has to be known. However, most studies report price elasticity for consumption of cigarettes. We have translated a decrease in cigarette consumption in a decrease in the prevalence of the different exposure categories. Elasticity for consumption of cigarettes then equals elasticity for the prevalence of smoking.

Based upon literature, we use a price elasticity of 0.7 for younger people (15-24 years), independent of the amount of cigarettes smoked. For people 25 years and older, we assumed the price elasticity to be 0.7 for the light smokers (< 15 cigarettes/day) and 0.4 for the other two smoking categories. The basic idea behind the two different price elasticity's is that younger people have less money and are therefore more sensitive for changing prices and the light smokers are assumed to quit more easily if the prices are too high. Prices will be expressed in Euro and the following currencies have been used, obtained from the Internet, February 1999 (www.xe.net/currency). One US dollar equals 0.891 Euro. The price per 20 cigarette packet in 1995 in US dollars is obtained from a WHO-report [WHO, 1997] for each country.

Table 4.1. Price of 20-cigarette packet in US dollars and in Euro of four European countries

	Price of 20-cigarette packet	
	US dollars	Euro
The Netherlands (1 Dutch guilder = 0.454 Euro)	2.82	2.54
England and Wales (1 UK pound = 1.456 Euro)	4.28	3.85
Denmark (1 Danish crown = 0.135 Euro)	5.03	4.53
Sweden (1 Swedish crown=0.112 Euro)	4.18	3.76

Table 4.2. Translation of an increase in price of cigarettes in a decrease in prevalence of smoking

Proportional increase of price of 20-cigarette packet per scenario (%)	Scenario's		
	one-Euro plus	10%-plus	Norway price
The Netherlands	39.4	10	91.3
England and Wales	26.0	10	25.6
Denmark	22.1	10	6.9
Sweden	26.6	10	28.7

	Decrease in prevalence of smoking (%)			
	1	2	1	2
The Netherlands	28	16	7	4
England and Wales	18	10	7	4
Denmark	16	9	7	4
Sweden	19	11	7	4

- 1: decrease for the subjects of 15-24 year old and light smokers; obtained by multiplying increase of price with 0.7-price elasticity
- 2: decrease for the subjects > 25 years and moderate and heavy smokers; obtained by multiplying increase of price with 0.4 price elasticity

From this we recalculated the price of a cigarette packet in Euro, which is shown in Table 4.1. For your information, we also give the current currency of the four countries.

In the "one-Euro plus scenario", the price of a 20 cigarette packet will be increased with 1 Euro in each country. This results in a different proportional increase of the price per country (see Table 2).

The "10%-plus scenario" is based upon a public health policy to increase the real price of cigarettes in the four European countries by the same percentage. We have used a 10% increase.

The "Norway price scenario" is based on the idea that all four European countries raise their prices to the level of the price of a 20 cigarette packet in Norway, which is 5.42 US dollar [WHO, 1997] or 4.84 Euro. Again, the percentage increase in price is different for each country, as can be seen in Table 4.2. Norway was chosen as this country had the highest price for a 20-cigarette packet in the European Union in 1995 [WHO, 1997].

From the percentage change in price, combined with price elasticity's, the change in prevalence is calculated for the four countries (see Table 4.2)

Table 4.3a. General characteristics of the four countries (men).

Men	The Netherlands				England & Wales				Denmark				Sweden			
Population (n)	7 535 127				25 198 100				2 554 594				4 320 954			
total	6 742 273				21 891 900				2 223 350				3 689 812			
0-64 yr	13				14				12				14			
Age distribution	13				13				13				12			
0-9	13				16				15				15			
10-19	17				15				14				14			
20-29	15				14				16				15			
30-39	15				11				11				11			
40-49	10				9				9				9			
50-59	8				6				6				7			
60-69	5				2				2				3			
70-79	2				0.2				0.2				0.3			
80-89	0.2															
90+																
Mortality (1990)																
age standardized																
annual death rate																
per 100 000 *	986				1 028				1 081				897			
- all causes	185				301				275				257			
- lung cancer	103				86				76				36			
- IHD																
smoking	36				28				36				22			
prevalence**																

From advertising restriction to decrease in prevalence: scenario 4

The last scenario, "the advertising ban scenario" is based upon another intervention strategy, namely restricting tobacco advertising. In 1991, Laugesen and Meads published a multivariate analysis of the effects of tobacco advertising policy in 22 countries in the period 1960-1986 [Laugesen and Meads, 1991]. The severity of tobacco advertising restrictions in each country and year was scored on a 0 to 10 scale. A zero score meant no restrictions. Two points were given for health warnings on cigarette packets, and one point each was given for a ban on advertising cigarettes in each of the following media: cinema, billboards, newspapers, magazines, points of sale, sponsorship, radio and television. The Netherlands, England and Wales, Denmark and Sweden scored 1.0, 6.0, 4.0 and 8.0 respectively in 1986. Applying the Laugesen and Meads criteria to the 1995 situation, yields scores of 6.0, 6.0, 6.0 and 8.0 respectively [WHO, 1997]. In this scenario we assume all countries to maximise their

Table 4.3b. General characteristics of the four countries (women).

Women	The Netherlands				England & Wales				Denmark				Sweden			
Population (n)	7 703 733				26 241 300				2 628 020				4 424 155			
total	6 511 146				21 356 700				2 153 929				3 539 180			
0-64 yr	12				13				11				13			
Age distribution	12				11				12				11			
0-9	16				15				15				14			
10-19	16				14				14				13			
20-29	14				13				15				14			
30-39	10				10				11				11			
40-49	9				10				10				10			
50-59	7				8				8				9			
60-69	4				5				5				5			
70-79	1				1				1				1			
80-89																
90+																
Mortality (1990)																
age standardized																
annual death rate																
per 100 000 *	568				647				698				550			
- all causes	79				143				137				117			
- lung cancer	16				31				38				15			
- IHD																
smoking	29				26				37				24			
prevalence**																

** Source [WHO, 1997];

***: percentage in persons 15 years and older in 1993-1994 [Laugesen and Meads, 1991]

advertising policy in 1995 to the 10-point score. This implies a 4.0 point increase for the Netherlands, England and Wales and Denmark and a 2.0 point increase for Sweden. In the Laugesen and Meads multivariate model, a one-point restriction score-increase was associated with a 1.4% reduction in consumption of cigarettes. The decrease in prevalence of smoking with a maximising advertising policy amounts thus 5.6% for the Netherlands, England and Wales and Denmark and a 2.8% decrease in Sweden. This decrease is assumed to be the same for all ages and all categories of smoking. These changes in smoking prevalence for the four scenarios are entered into PREVENT 2.8 and subsequently the effects on total and cause-specific mortality was estimated.

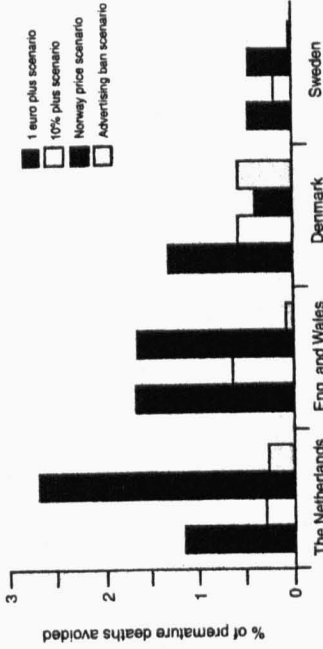

Figure 4.1. Total mortality reduction in men younger than 65 years in simulation year 2035 after four anti-tobacco interventions. Expressed as percentage of total mortality in men aged 0-65 years.

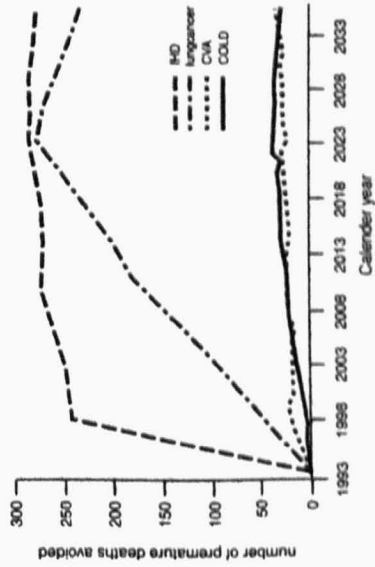

Figure 4.2. Total mortality reduction in men younger than 65 years in simulation year 2035 after four anti-tobacco interventions. Expressed as percentage of total mortality in men aged 0-65 years.

4.3 RESULTS

Table 4.3 shows relevant characteristics of the four countries. The population size ranges from 5 million in Denmark to 51 million in England and Wales. The age-distribution within each population is similar. Mortality from ischaemic heart disease is relatively low in the Netherlands, in men as well as in women. Lung cancer mortality in Dutch men is high, whereas in Swedish men it is low, compared to the other countries.

In Figure 1, the reduction in total mortality in men younger than 65 years of age is shown for the four intervention scenarios, for the simulation year 2035. The reduction is expressed as percentage of deaths avoided of the total number of deaths in the age group 0-65 years. In the Netherlands, the "Norway price scenario" shows the largest effect in terms of avoided premature deaths, in Denmark, the "one-Euro plus scenario" has the biggest impact. The pattern for women is similar, although the maximum impact is lower compared to men (Figure 2).

To illustrate how the health gain of an intervention changes over time, we selected one scenario, the "one-Euro plus scenario". In the Figures 3-6, the effect of this intervention is shown for men over the period 1993-2035, expressed as the number of premature disease-specific deaths avoided. The numbers are more or less proportional to the population size, thus being largest in England and Wales. In all countries, more or less the same pattern is shown. For lung cancer mortality it takes a longer period to reach the maximum effect, due to a longer LAG-time (30 years). The largest effect of the intervention scenario's can be found for ischaemic heart disease and lung cancer.

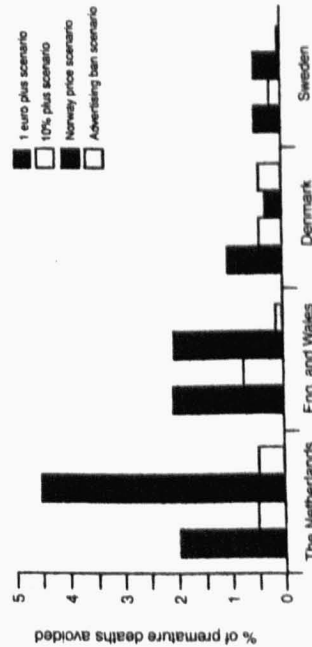

Figure 4.3. Mortality reduction in men younger than 65 year from the Netherlands after a 1-Euro price increase of cigarettes

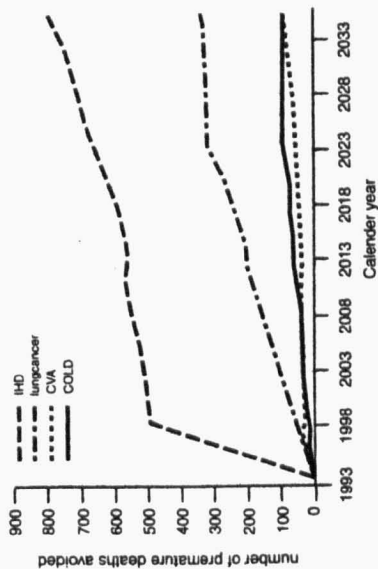

Figure 4.4. Mortality reduction in men younger than 65 year from England and Wales after a 1-Euro price increase of cigarettes

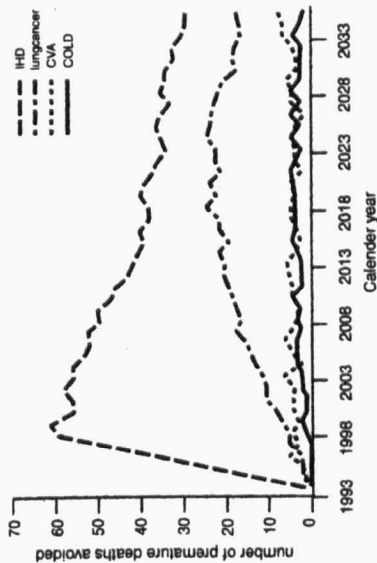

Figure 4.6. Mortality reduction in men younger than 65 year from Sweden after a 1-Euro price increase of cigarettes

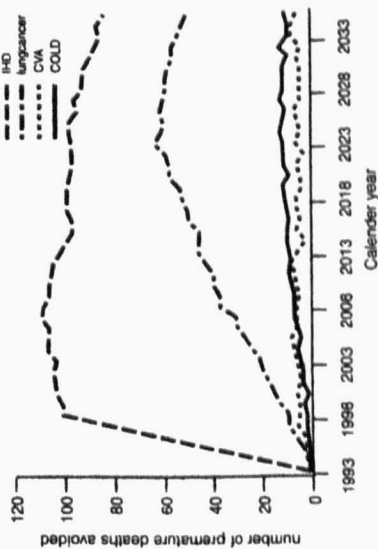

Figure 4.5. Mortality reduction in men younger than 65 year from Denmark after a 1-Euro price increase of cigarettes

4.4. DISCUSSION

We have estimated the effect of four different anti-tobacco scenario's in terms of number of deaths avoided in four different countries. Depending on the current situation in a country, the different scenarios have more or less effect. The scenarios defined for these analyses are realistic. The effect, expressed in number of deaths avoided, are generally small. On average a price increase scenario has more effect as compared with the advertising ban scenario in each country.

Several factors play a role in the effect of an intervention in a specific country. First, the history of the tobacco control policy is of importance. In the Netherlands, the price of a 20-cigarette packet is low, compared to the other three countries. Increasing the price with one Euro or to the Norwegian price has therefore a larger proportional increase in the price. Whereas the "10%-plus scenario" show less impact as a 10 percent increase of little is still a low increase. In Denmark and Sweden on the other hand, the price of a packet is higher and therefore you see a larger impact of the "10%-plus scenario" and less for the "Norway price scenario" or the "one-Euro plus scenario". Next, the history of smoking behaviour in a country determines the effect of the interventions. For example, in the Netherlands, men were smoking heavily already in the seventies, which reflected in their high current lung cancer mortality. In addition, the absolute prevalence of smoking has its influence in the health benefits of the scenario's. As smoking prevalence in Denmark is higher compared to Sweden, a larger absolute number of premature deaths is

avoided in Denmark as compared to Sweden, although the population size in Denmark is 60% of that in Sweden.

For the evaluation of the interventions on smoking as described in this paper, empirical data on the effect of price elasticity are needed. Such a price elasticity in the case of smoking seldom fit epidemiological data easily. Most studies report on price elasticity for consumption of cigarettes, while the input in PREVENT 2.8 are data on prevalence of smoking and thus the effect of price elasticity on the prevalence of smoking has to be known. In this particular case we have assumed that a decrease in cigarette consumption leads to a lowering of the number of cigarettes smoked per smoker per day and thus to a downward shift in the prevalence of smoking in each category of exposure including a proportional number of individuals who completely quit smoking. This is an illustration of the assumptions necessary in such scientific exercises. The importance of such a comparative analysis lies first in the ability to show the importance of such local/national characteristics on a "universal" health policy measure. One often has a tendency to assume that the universal truth of epidemiological research will lead to similar policy conclusions in all situations. These country specific scenarios show a very different picture. Secondly, and may be more relevant for the European Union, is the question raised by this analysis concerning the goal of a common European health promotion policy as authorised in the treaty's of Maastricht and Amsterdam. Does one aim at "one common" policy or does one aim for a reduction in the existing differences in health status, or for an equal health benefit to be achieved in each Member state?

Also, what reference population is used when estimating potential health benefits? It is clear from this analysis that country specific health status and policy histories determine the potential benefits of future health promotion interventions. It is its diversity that offers insights into the effects of European policies.

Therefore much is to be said for country specific but comparable instruments to estimate these country specific benefits. Computer simulation models like PREVENT 2.8 offer such a tool, but its implementation to member states of the European Union should not be taken lightly.

C.A. Baan, J.M. Mooy
L.J. Gunning-Schepers

Corresponding address:

*Department of Public Health
Erasmus University Rotterdam
P.O. Box 1738
3000 DR Rotterdam, the Netherlands
email: baan@mgz.fgg.cur.nl*

4.5. REFERENCES

- WHO. Tobacco or health. First Global status report. 1997
- Laugesen M, Meads C. Tobacco advertising restrictions, price, income and tobacco consumption in OECD countries, 1960-1986. *Br J Addiction* 1991;86:1343-1354.