

LONDON
SCHOOL *of*
HYGIENE
& TROPICAL
MEDICINE



**Long-term population effects of pneumococcal vaccines on
carriage of pneumococcal serotypes and subsequent disease in
Kenya**

JOHN OWINO OJAL

Thesis submitted in accordance with the requirements for the degree
of
Doctor of Philosophy
University of London
2018

Department of Infectious Disease Epidemiology

Faculty of Epidemiology and Population Health

LONDON SCHOOL OF HYGIENE & TROPICAL MEDICINE

Funded by KEMRI-Wellcome Trust Research Programme

Research group affiliation(s): KEMRI-Wellcome Trust Research Programme
The Vaccine Centre - LSHTM
Centre for the Mathematical Modelling of Infectious Diseases - LSHTM

Declaration by candidate

I, John Owino Ojal, declare that this thesis is my own work. Whenever I have referred to work that is relevant to this thesis and not done by myself, I have duly acknowledged it.

Signed:

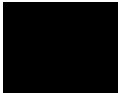

Date: 11th September 2017

Abstract

Many African countries, like Kenya, have introduced pneumococcal conjugate vaccines (PCVs) with financial support from Gavi, the Vaccine Alliance. However, in the near future, they are expected to transition and take up the full costs. Kenya introduced the ten-valent PCV (PCV10) in 2011 and enters the accelerated transition phase in 2022. This work aimed to study the effects of PCV10 vaccination on pneumococcal carriage and disease in the pre- and the immediate post-vaccination period, predict the long-term vaccination impact on carriage of pneumococcus and subsequent invasive pneumococcal disease, evaluate immune factors that may influence that impact and, ultimately, investigate the cost-effectiveness of potential policy options in order to guide Kenya's decision-making.

A dynamic transmission model was fitted to pre-vaccination carriage data and its predictions were validated against post-vaccination carriage data. In order to evaluate immune factors that may influence vaccination impact and thus warrant consideration in the mathematical model, statistical modelling of the association between pre-existing pneumococcal carriage and vaccine responsiveness, and between maternally-derived anti-protein and anti-capsular antibodies and the rate pneumococcal acquisition in newborns, was undertaken. A cost-effectiveness analysis was done based on the disease incidence predictions from the transmission model.

The dynamic transmission model was shown to be useful as it closely predicted the observed magnitude and timing of serotype replacement. Maternal anti-capsular antibodies were estimated to have a limited role while impaired immune responses were observed among vaccine serotype carriers at the point of vaccination. These two immune factors were evaluated within the decision making structure and considered to have negligible impact

on the performance of the model. In the conclusion, I estimated that sustaining PCV10 vaccination in Kenya will be cost-effective but will present a significant challenge to affordability by the Kenyan Government.

Acknowledgements

I thank my director of studies Prof. Anthony Scott immensely for the professional guidance he gave throughout the duration of the PhD study. I extend similar a gratitude to my co-supervisor Dr. Stefan Flasche. I am indebted to both Prof. Kari Auranen and Dr. Markku Nurhonen from Finland who introduced me to the world of mathematical modelling.

The data used in this research work has been collected through years of effort from dedicated colleagues at the KEMRI-Wellcome Trust research programme in Kilifi, Kenya. I especially appreciate Mr. Donald Akech for the coordinating the pneumococcal carriage surveys. My officemates, Sophy Uyoga, Olive Akunga, Alex Macharia, Juliet Otieno, Oscar Nyangiri and Ngure Kagia encouraged me at any opportunity.

I value the sacrifice my parents, Alex Ojal and Peres Ojal, went through to afford me some education. Finally, I deeply appreciate the moral support of my lovely wife Dr. Esther Muthumbi through the journey.

Preface

This PhD thesis is written in a research paper style format. The first chapter is a general introduction to the pneumococcus and pneumococcal vaccines and their impact. It also outlines the gaps in knowledge and sets the theme for the four manuscripts, each as a chapter, that follow. Three of the manuscripts are already published in peer-reviewed journals. The last manuscript is in preparation for submission. The last chapter in the thesis integrates the results of the four discrete but related investigations to attempt to give an answer to the problems posed in the introduction chapter.

Table of contents

Declaration by candidate.....	2
Abstract.....	3
Acknowledgements	5
Preface	6
Chapter 1: General introduction	8
1.1 Context.....	8
1.2 The pneumococcus.....	8
1.3 Burden of disease caused by the pneumococcus.....	11
1.4 Protection from maternally-derived anti-pneumococcal antibodies.....	12
1.5 Pneumococcal vaccines.....	13
1.6 Impact of PCVs on carriage of pneumococcus and subsequent disease	15
1.7 Immune correlates of protection against disease and carriage.....	19
1.8 Hyporesponsiveness.....	20
1.9 Roll out of Pneumococcal vaccines	21
1.10 The future of PCV vaccination in Kenya.....	23
1.11 Research objectives	23
1.12 Approach used in tackling the research objectives	24
References.....	29
Chapter 2: Research paper 1	40
Chapter 3: Research paper 2	85
Chapter 4: Research paper 3	111
Chapter 5: Research paper 4	145
Chapter 6: General discussion	181
1.1 Summary of findings	181
1.2 Limitations	186
1.3 Future work	190
1.4 Conclusion	193
Appendix 1: Ethical approval for statistical analysis	197
Appendix 2: Ethical approval for mathematical modelling work.....	198
Appendix 3: Typeset published papers	199

Chapter 1: General introduction

1.1 Context

Many African countries, like Kenya, have introduced pneumococcal conjugate vaccines (PCVs) with financial support from Gavi, the Vaccine Alliance. However, in the near future, they are expected to transition and take up the full costs. Kenya introduced the ten-valent PCV (PCV10) in 2011 and enters the accelerated transition phase in 2022. Therefore, a cost-effectiveness study of the potential policy options is useful in guiding Kenya's decision making on the future of its PCV vaccination programme. This work aimed to study the effects of PCV10 vaccination on pneumococcal carriage and disease in the pre- and the immediate post-vaccination period, predict the long-term vaccination impact on carriage of pneumococcus and subsequent invasive pneumococcal disease, evaluate immune factors that may influence that impact and, ultimately, investigate the cost-effectiveness of potential policy options.

1.2 The pneumococcus

Streptococcus pneumoniae (*Pneumococcus*) is a gram-positive bacterium, which takes the shape of a slightly pointed coccus. It usually occurs in pairs but can also exist singly or in short chains and it colonises the mucosal surfaces of the nasopharynx and upper respiratory tract. It is characterized by a polysaccharide capsule, which when present covers the entire cell, the basis upon which the pneumococcus is typed; there are over 90 known serotypes to date [1,2]. The capsule also plays an important role in the virulence of the bacterium. The capsule protects against non-opsonic killing of the bacterium by human neutrophils. The susceptibility to killing is directly linked with the degree of encapsulation where serotypes that are heavily encapsulated are more resistant to neutrophil-mediated

killing [3]. Most pneumococcal capsules are negatively charged [4]. The negative charge repels phagocytes through electrostatic repulsion, which enhances colonisation. Also, pneumococcal strains with highly negatively charged capsules are less likely to adhere to human airway mucus therefore preventing clearance by mucus [4,5]. Upon adherence of pneumococci to epithelial cells, the thickness of the capsule is reduced. This results in the exposure of adhesion molecules and allows pneumococci to strengthen the attachment to host cells enhancing subsequent uptake [6]. The pneumococcus also contains proteins that control the host-pathogen interactions. These proteins have varied roles including ensuring viability of the pneumococcus [7–10] and determination of virulence, as is the case for the group of choline-binding surface proteins [11–13]. About 30-50% of pneumococcal strains express pili on their cell surface and this aids in attachment to the host epithelial cells [14], however, the pili are not essential for attachment. The pneumococcus is mostly found in humans though the host can range from mice, rats, guinea pigs, rhesus monkeys to chimpanzees.

Transmission of pneumococcus from one human host to another is normally through infectious droplets that are passed across by coughing or sneezing or very close person-person contact e.g. oral contact [15–18]. There exists intra-species competition among pneumococci in colonising the human nasopharynx and different serotypes of pneumococci vary in their competitive abilities. The biological mechanism of competition between pneumococcal serotypes is not yet known. Between-serotype competition has however been postulated and quantified based mathematical models fitted to epidemiological data [19,20] or mouse experimental colonisation models [21]. In mathematical models, a competition structure where the rate of acquisition of a second serotype in an already colonised individual is lower than the rate of acquisition of that

second serotype in a completely susceptible individual is supported better by epidemiological data (i.e. better model-fit) than a competition structure where the clearance of a resident serotype is enhanced by the acquisition of a second serotype. In a mouse model of intranasal carriage of pneumococci, carriage of a resident strain inhibited the acquisition of a challenge strain and this inhibitory effect depended on the dose of the challenge strain [21]. Challenge with a secondary strain did not significantly influence the rate of clearance of the resident strain. This experimental observation is compatible with the assumptions of mathematical models about between-serotype competition structures that are best supported by epidemiological data. Therefore between-serotype competition is believed to essentially work through acquisition rather than clearance [19–21].

The duration of carriage, which is a function of the clearance rate, varies across serotypes and reduces with age [20,22–24]. Two potential explanations for the reduction in duration of carriage with age include: (i) the natural immunity acquired after exposure to pneumococcal carriage that reduces duration of carriage in subsequent episodes [25,26] and: (ii) the maturation of immune responses with age that are independent of natural exposure [27]. Given that some serotypes are poor competitors in colonising the nasopharynx and are more easily cleared from it, it has been shown, in a mathematical modelling study, that the diversity of pneumococcal serotypes is maintained because of weak serotype-specific immunity that stabilizes competition, and acquired non-capsular immunity that reduces the serotype-specific differences in fitness, like duration of carriage [28]. Anti-capsular antibodies drive serotype-specific immunity against homologous colonisation [29–31]. Weak serotype-specific immunity allows repeated colonisation of a host with a serotype that has previously been encountered naturally. Non-capsular immunity is driven by an immune mechanism mediated by interleukin 17 produced by

Th17 T cells as demonstrated in mouse models [26,27]. This type of immunity has been observed in longitudinal studies in humans [32,33].

Pneumococci carried in the nasopharynx can spread to other parts of the body causing various forms of non-invasive and invasive pneumococcal diseases. The non-invasive pneumococcal diseases include acute otitis media and non-bacteraemic pneumonia. Acute otitis media is caused by direct spread of the pneumococcus through the Eustachian tubule and is characterized by inflammation of the middle ear and swelling of the eardrum. Non-bacteraemic pneumonia is caused by direct spread through the trachea to the lower respiratory tract without isolation of pneumococcus in blood and is diagnosed by chest radiographs. Invasive pneumococcal disease (IPD) occurs when the pneumococcus invades sterile sites such as the blood stream or the cerebrospinal fluid, causing bacteraemia/sepsis, or meningitis.

1.3 Burden of disease caused by the pneumococcus

The burden of pneumococcal disease is mainly concentrated in children younger than 5 years and in the elderly [34,35]. In 2000, before the introduction of pneumococcal vaccines, the World Health Organization (WHO) estimated that pneumococcal diseases led to 1.6 million deaths worldwide. Over half of these deaths (0.83 million) were in children under 5 years. Pneumococcus was estimated to cause around 11% (8–12%) of all deaths in children aged 1–59 months, not including pneumococcal deaths in HIV-positive children [34]. Furthermore, the highest incidence and case-fatality rates were estimated to occur in sub-Saharan Africa and Southeast Asia. In 2008, the WHO estimated that there were 0.5 million deaths due to pneumococcal diseases in children under 5 years [36].

More recent global estimates of mortality caused by the pneumococcus are being updated and will become available later in 2017 [37].

1.4 Protection from maternally-derived anti-pneumococcal antibodies

Exposure to pneumococcus in the natural environment of pregnant women can induce natural antibodies against the pneumococcal strains encountered [31,38]. These naturally-acquired antibodies can be passively passed on to the foetus through trans-placental diffusion in the late stages of pregnancy [38]. The transfer of antibodies across the placenta is not very efficient, especially for polysaccharide antigens [39], which means that the antibody concentration in the infant at birth is normally lower than that in the mother. These circulating maternally-derived antibodies could potentially protect infants from colonisation, which is a necessary precursor for invasive disease [40]. However, several studies have documented the limited role of maternally-derived antibodies in protecting infants from pneumococcal colonisation [33,38,41].

Three limitations of the studies of newborn pneumococcal colonisation and maternally-derived antibodies [33,38,42–44] might mask a potential association. (1) Children born to carrier mothers have a higher risk of being infected by the mother; as maternal carriage may stimulate a maternal antibody response, they are also more likely to receive higher antibody concentrations by passive transfer from the mother. Therefore, failing to account for the colonisation status of the mother at birth would confound the estimate of the protective role of antibodies. (2) The first swabs were obtained at 1 month of age at the earliest and the inter-swab interval was also at least a month [33,38,43–46]. The duration of carriage of some pneumococcal serotypes in young infants can be less than a month [20,22]. An insensitive ascertainment of carriage in infants can result in an increased

number of missed carriage episodes. (3) The relatively small sample size of these studies has limited the power to detect modest protective efficacies. We need studies that overcome these limitations to determine an un-biased characterization of the impact of maternally-derived antibodies on infant pneumococcal carriage and subsequent disease. By extension these would provide un-biased information on which to base potential vaccination strategies or modelling assumptions.

1.5 Pneumococcal vaccines

The first vaccines introduced against pneumococcus were derived from purified capsular polysaccharide, and these could be pooled to offer multi-serotype protection. A polysaccharide vaccine that is still in current use is the 23-valent pneumococcal polysaccharide vaccine (PPV23). It protects against 23 serotypes of pneumococcus (1, 2, 3, 4, 5, 6B, 7F, 8, 9N, 9V, 10A, 11A, 12F, 14, 15B, 17F, 18C, 19F, 19A, 20, 22F, 23F, and 33F). However, polysaccharide vaccines are poorly immunogenic in young infants [47,48]. In a trial with a 14-valent polysaccharide vaccine, children who were less than two years old at the time of primary vaccination were given a booster dose six months later. There was no significant increase in antibody to any serotype post-booster, and the geometric mean antibody levels waned for most types [47]. In a study among children in Finland, aged less than 7 years, there was poor immunogenicity to serotypes 6A and 23F – serotypes that frequently cause pneumococcal infections in children. In addition, children younger than 2 years of age also responded very poorly to serotypes 19F and 18C [48]. Currently, polysaccharide vaccines are not recommended in children younger than two years of age. The PPV23 has been mainly used in high-risk groups of older children and adults such as those with immunodeficiency or those aged above 65 years.

The cause of the poor immunogenicity of polysaccharide vaccines in children under 2 years is not completely understood. The free polysaccharide antigens induce thymus-independent anti-polysaccharide antibody responses, which are not fully developed in infants [49–51]. Reduced thymus-independent responses are attributed to the low numbers of marginal-zone B-cells present during birth and these are poorly developed in neonates [51] and in young children [52]. Thymus-independent antigens do not require T-cells to induce immunological response and therefore they do not induce immunological memory.

An interesting observation regarding polysaccharide vaccines is that repeated vaccination is associated with hyporesponsiveness (i.e. reduced immunological response) [53], which can be long lasting in asplenic children [54] and can be overcome, in the elderly, if the two doses are administered at least five years apart [55,56]. Furthermore, polysaccharide vaccines have not been shown prevent nasopharyngeal carriage in children [57,58] and by extension transmission of pneumococcus, therefore, they do not elicit herd-protection in the population. However, in adults, immunisation with specific capsular polysaccharides greatly reduced the incidence of pneumonia caused by pneumococci in vaccinated individuals and non-vaccinated individuals who frequently interacted with vaccinees [59].

As polysaccharide vaccines are not protective in infants, vaccine formulations that could stimulate immunity even in young children were explored. The idea of conjugating the polysaccharide to an immunogenic protein carrier was conceived in the early 1930s where the immunological specificity of an antigen prepared by combining the capsular polysaccharide of type III pneumococcus with foreign protein was described [60]. This led to the development of the first glycoconjugate vaccine for use in humans, a *Haemophilus influenzae* type b (Hib) conjugate vaccine, that was licensed in the USA in 1987 and

introduced into the US infant immunization schedule [61]. Pneumococcal Conjugate Vaccines (PCVs) were subsequently formulated by conjugating pneumococcal polysaccharides to carrier proteins. The carrier proteins stimulate the immune system through T-helper cells [62,63] which activate polysaccharide-specific B cells to proliferate and differentiate into plasma cells, thus making the conjugate vaccines immunogenic even in infants and young children. However, the process of conjugation is complex which has limited the number of serotypes that can be included in a vaccine and led to high manufacturing costs. The first PCV included antigens against seven serotypes - 4, 6B, 9V, 14, 18C, 19F and 23F. Successively, more serotypes have been included in PCVs and 10-valent (PCV10 serotypes 1, 4, 5, 6B, 7F, 9V, 14, 18C, 19F and 23F), and 13-valent (PCV13 serotypes 1, 3, 4, 5, 6A, 6B, 7F, 9V, 14, 18C, 19A, 19F and 23F) conjugate vaccines have been licensed and are now widely in use.

Other formulations of pneumococcal vaccines that are in clinical development include pneumococcal whole cell vaccines and protein vaccines [64–66]. Because these vaccines are not targeted at specific capsular polysaccharides they are expected to protect recipients against all serotypes of pneumococcus.

1.6 Impact of PCVs on carriage of pneumococcus and subsequent disease

Impact on carriage

Reduction in nasopharyngeal carriage of vaccine-serotype pneumococci has been documented after vaccination with PCVs [67–69]. In a meta-analysis of individually randomised studies of the efficacy of PCV7 against carriage [70], the aggregate vaccine efficacy against vaccine serotype carriage was estimated as 57% (95% credible interval:

50-65%) 6 months after completion on the vaccination schedule. The peak vaccine efficacy, measured two months after completion of vaccination schedule, was estimated as 62%. Moreover, by reducing the likelihood of acquisition of the pneumococcus in the nasopharynx, conjugate vaccines reduce pneumococcus transmission and thereby offer indirect protection against IPD to the unvaccinated, herd immunity. For example, in the Active Bacterial Core Surveillance (ABCs) in USA there was an estimated decline of between 64–77% in vaccine serotype IPD from pre-introduction of PCV7 to 4 years post-introduction among adults [71]. In England and Wales, vaccine serotype disease decreased in all age groups; there was a reduction of 98% in individuals younger than 2 years and of 81% in those aged 65 years or older 4 years following introduction of PCV7 [72]. However, non-vaccine-serotype pneumococci rapidly colonise this vacated ecological niche which gives rise to near-complete serotype replacement carriage where the overall carriage prevalence remains unchanged [73–76]. This leads to serotype-replacement disease the extent of which depends on the invasiveness of the replacing serotypes, therefore, ongoing surveillance post-introduction is always necessary, but this is not in place for most developing countries that have introduced PCVs. In contrast to developed countries [71], circulation of vaccine serotypes in low-income countries has not been eliminated. Data from Kenya [77] and The Gambia [78] suggests that the prevalence of vaccine serotypes remains high several years after vaccine introduction. In infants, the prevalence of PCV7 serotypes was estimated at 5% in The Gambia in 2012 [78] and the prevalence of PCV10 serotypes was estimated at 8% in Kenya [77]

Impact on disease

Despite the impact of serotype replacement, PCVs have been shown to be efficacious in preventing serious forms of vaccine-type pneumococcal disease [71,74,79–92],

radiologically-confirmed pneumonia [85,87,93,94] and acute otitis media (AOM) [95–98]. The duration of protection of PCV against disease can be as long as 6 years [99]. The efficacy of PCV is higher against vaccine-serotype pneumococcal disease than against radiologically-confirmed pneumonia or AOM. This is because the later endpoints are not specific for pneumococcal aetiology; vaccine efficacy would be biased downwards when there is low specificity of the endpoint. Both radiologically-confirmed pneumonia [100] and AOM [101,102] have many aetiologies including but not limited to *Streptococcus pneumoniae*, *Haemophilus influenzae*, and *Moraxella catarrhalis*. Therefore, PCV can only be expected to prevent the portion of radiological pneumonia and AOM with vaccine-serotype pneumococcal aetiology.

There are few individually randomised trials in Africa on the efficacy of PCVs against disease. In a randomised placebo-controlled trial in The Gambia among children aged 6 to 51 weeks, the efficacy of the 9-valent PCV was estimated to be 37% against the first episode of radiologically-confirmed pneumonia while the efficacy against vaccine serotype IPD and all IPD was 77% and 50%, respectively [93]. In a randomised controlled trial in South Africa, where children were vaccinated at ages 6, 10 and 14 weeks, the efficacy of a 9-valent PCV against the first episode of IPD among HIV negative and HIV positive children was 83% and 65% respectively [94].

Effectiveness studies from population-based surveillance in some African countries have also reported a reduction in disease following PCV introduction. South Africa introduced PCV7 in 2009 and replaced it with PCV13 in 2011. The rate of IPD among all ages dropped by 40% by 2012 [103]. The Gambia introduced PCV7 in 2009 and replaced it with PCV13 in May 2011. Using population-based surveillance and nested case-control studies, PCV vaccination in The Gambia was associated with a reduction in the incidence

of radiologically-confirmed pneumonia by 23%, 29% and 22% in children aged 2-11 months, 12-23 months and 2-4 years, respectively, up to the period 2014/15. The reduction in the incidence of pneumococcal pneumonia was 58%, 75% and 57%, respectively, in the same age groups [104]. Using the period before the introduction of PCV13 as the baseline (May 12, 2008–May 11, 2010) and a post vaccination period spanning two years (Jan 1, 2013–Dec 31, 2014), the incidence of IPD reduced by 55% and 56% in children aged 2-23 months and 2-4 years respectively [105].

Mozambique introduced PCV10 in March 2013. Over three years after PCV introduction, data from three main sentinel hospitals have recorded a steep decline in pneumococcal meningitis cases in children below of the age of five years. The proportion of cases of pneumococcal meningitis decreased from 33.6% to 1.9% in 2015 among children with suspected acute bacterial meningitis [91].

Kenya introduced PCV10 at the beginning of 2011. In Kilifi, a coastal area in Kenya with enhanced surveillance for IPD and carriage prevalence, the vaccine was introduced with a catch-up campaign among children <5 years. Vaccine-type pneumococcal carriage and IPD dropped substantially in all age groups. Carriage of vaccine serotypes was reduced by two-thirds both in children younger than 5 years and in older individuals [77,106]. In children <5 years, the incidence of vaccine-serotype IPD fell by 92% while the overall IPD decreased by 68% in the post vaccination period (2012-2016) [107]. Among children aged 2-59 months in Kilifi, PCV10 introduction was associated with a reduction in clinically-defined and radiologically-confirmed pneumonia of 27% and 48%, respectively [108].

1.7 Immune correlates of protection against disease and carriage

PCVs induce an immune response characterized by an increase in the anti-capsular antibodies to the antigens contained in the vaccine. High levels of vaccine-induced anti-capsular antibodies have been associated with reduction in IPD [109,110] and pneumococcal carriage [111]. For IPD a common correlate of protection (CoP) across vaccine-serotypes of 0.35 mcg/ml was derived for PCV7 [109,112] and used for licensing extended formulations of PCV such as PCV10 and PCV13 [113]. However, the use of a single CoP has recently been criticized as the threshold varied widely across serotypes in PCV13 [114]. The statistical method used to derive the CoP for IPD equated relative risk of IPD between vaccine and control groups (i.e. one minus the vaccine efficacy) to the relative risk of having antibody concentration below the protective threshold. Then, the protective threshold was derived from reverse cumulative distribution curves of the antibody concentrations of the vaccinated and the control groups as the concentration at which this equation is satisfied [112]. A key simplifying assumption of the approach is that the relationship between the risk of disease and antibody concentration is a step function, where the risk of disease above the threshold is negligible (all or nothing protection), which can be violated in reality.

Carriage is a precursor to IPD [40] and is an endpoint that is both easy and faster to measure relative to IPD. In addition to preventing disease, a vaccine that prevents transmission confers herd protection against carriage and disease and therefore has additional value. This is worth considering when licensing future pneumococcal vaccines. Carriage has therefore become a target for vaccine development [115] and future vaccine development will benefit from a better understanding of the relationship between antibody development and reduced carriage. In this context, a clear CoP against carriage would be

a useful output in the characterisation of the antibody-carriage relationship. However, there is only one study, conducted in the United Kingdom, that has identified a clear correlate of protection against carriage and this is for only a single serotype [31]. In this study, individuals with antibody concentration above 5mcg/ml were protected against acquisition of serotype 14. Nonetheless, the study used data from adult subjects, which might limit the application of the threshold in children, and related carriage to naturally-acquired antibodies rather than vaccine-induced ones.

1.8 Hyporesponsiveness

Even though children mount an immune response after vaccination with PCV, the magnitude of this response is dependent on the carriage status at the time of vaccination. Individuals with prevalent carriage at the time of vaccination have an impaired response leading to lower concentration of homologous antibody post-vaccination [116–121]. PCV responses in African children are generally thought to be higher than those seen in developed country settings [79,122–124]. For example, the serotype-specific geometric mean fold-rise after a 3-dose primary series of PCV was lower in USA [79] and Finland [124] compared to South Africa [122] and The Gambia [123]. Since carriage rates in early infancy are extremely high in countries like The Gambia [125] and Kenya [106,126], it is possible that hyporesponsiveness does not occur, or is immunologically irrelevant, in tropical Africa. However, no study in Africa has yet examined the question of hyporesponsiveness. If the reduced responsiveness among carriers leads to lower immunogenicity then vaccination strategies that speedily reduce carriage in the whole population, such as catch-up campaigns, might be more effective than cohort introduction. Hyporesponsiveness might also impact on the fit of mathematical models of carriage if not

included in the mechanistic structure, depending on the magnitude of the resulting reduction in vaccine efficacy.

1.9 Roll out of Pneumococcal vaccines

PCV7 was the first conjugate vaccine licensed for use in infants in the United States of America (US) in the year 2000. By August 2008, PCV7 had been introduced in 26 high-income countries. However, the conjugate vaccines were not introduced in developing countries until the year 2009 when Rwanda announced the introduction of PCV7 in its childhood immunization programme. The delay in the roll out of PCV vaccination programs in developing countries was mainly caused by the high vaccine price. According to the US Centers for Disease Control and Prevention (CDC), the contract price for PCV7 in 2001 was US \$45.99 per dose and US \$58.75 per dose in the private sector [127]. When PCV13 was introduced in the US in 2010, the CDC contract price was US\$91.75 per dose, currently (2017) it is US\$126.97 per dose [128].

In order to lower the cost of production and by extension the vaccine price per dose, vaccine-manufacturing companies would need to increase the manufacturing capacity to take advantage of economies of scale. With limited supply, the price of vaccine would be too high for developing countries. However, manufacturers would not have the incentive to make huge investments if there is no matching demand for the vaccines, which creates a stalemate.

In the Latin American and Caribbean (LAC) countries, PCV vaccination was introduced largely with the support of a bulk procurement mechanism for vaccines and related supplies [129]. This mechanism was operated by the Pan American Health Organization

(PAHO) revolving fund [130] in which forty-one member countries pool their resources to procure vaccines in bulk at lower prices. PAHO prices for PCV10 and PCV13 have declined slightly from US\$14.24 and US\$16.34, respectively, in 2012 but remain high at US\$12.85 and US\$14.50, respectively, in 2017 [131].

In many developing countries in Africa, PCVs were introduced through financial support from Gavi, the Vaccine Alliance. Gavi developed an innovative vaccine funding and delivery mechanism known as the pneumococcal Advanced Market Commitment (pneumococcal AMC). Under the pneumococcal AMC, donors committed funds for vaccine procurement and Gavi made an advanced commitment to manufacturers to purchase specific volumes of vaccine meeting specific requirements (target product profile); this gave vaccine manufacturers the incentive to invest in expanding their manufacturing capacity and in vaccine research. In return companies signed a legally-binding commitment to provide the vaccines at an agreed price to developing countries in the long term, ten years [132].

Countries with an average Gross National Income (GNI) per capita of less than \$1580 over the three years before application to Gavi are, in principle, eligible for support from Gavi for introduction of PCV vaccination in their childhood immunization programs. As of March 2017, 59 developing countries had been approved for pneumococcal vaccine support and more than 50 of them had introduced PCV [133]. Initially, countries are expected to pay a small fraction (6%) of the agreed vaccine price, which is currently \$3.05, in a co-financing agreement, while Gavi pays the rest. However, as each country's GNI grows and goes above the eligibility threshold it enters the accelerated transition phase where, within five years, it is expected to take up the full cost of the vaccine [134].

1.10 The future of PCV vaccination in Kenya

Gavi's initiative to help developing countries access PCVs has been a success, considering the uptake of PCVs and the subsequent impact of vaccination in reducing the burden of pneumococcal disease in these countries. The challenge that remains for countries that have depended on Gavi support is how to sustain the programmes once they transition out of Gavi support. At the moment four African countries (Angola, Congo Rep., Ghana and Nigeria) are in the accelerated transition phase [134] and five more (Ivory Coast, Lesotho, Sudan, Kenya and Zambia) are expected to join within the next five years.

Kenya is expected to enter the accelerated transition phase in 2022 which should lead to taking up the full cost of the PCV vaccination programme by 2027 [135]. Policy makers in Kenya will need to decide in 2022 whether to enter the accelerated transition phase or alter or discontinue the programme. PCV is the most expensive vaccine in the national immunization programme. However, for most African countries the decision to introduce PCV was not preceded by an evaluation of the balance of predicted costs and benefits of PCV introduction because Gavi provided the majority of vaccine costs. For Kenya, with good local data on disease burden and impact, the decision to continue or amend the PCV programme should be based on a rational process informed by infectious disease modelling and cost-effectiveness analyses.

1.11 Research objectives

The overall aims of the research presented in this thesis are to:

1. Model the effects of PCV10 vaccination on pneumococcal carriage and disease in the pre- and the immediate post-vaccination period.
2. Predict the long-term vaccination impact on carriage of pneumococcus and subsequent invasive pneumococcal disease
3. Evaluate immune factors that may influence that impact
4. Investigate the cost-effectiveness of upcoming policy options in order to guide decision-making.

1.12 Approach used in tackling the research objectives

To produce valid estimates of the cost-effectiveness of PCV, observed and modelled incidence estimates for IPD and/or those of other non-invasive pneumococcal diseases are required. Disease incidence estimates are used to calculate the treatment and other related costs and to estimate the disability-adjusted-life-years (DALYs). However, disease prediction models are subject to a host of influencing factors that demand consideration. The principal problem with limited-valency vaccines is serotype replacement: the rapid colonisation of the vacated ecological niche by non-vaccine-type pneumococci, which results in serotype replacement disease. The additional impact of PCV vaccination on carriage and disease, through herd immunity, also needs to be accounted for. Other factors, such as social contact patterns, can also influence transmission of carriage. Mathematical transmission models are useful tools in encompassing these dynamics and have been used in predicting PCV vaccination impact [74,75,136–139]. I use transmission modelling in this thesis for prediction of vaccination impact.

Mathematical transmission models require data for calibration and validation. I use data that is mainly collected within the Kilifi Health and Demographic Surveillance System

(KHDSS) [140]. KHDSS is housed within the Kenya Medical Research Institute-Wellcome Trust Research Programme (KWTRP) in Kilifi, which is located on the Indian Ocean coast of Kenya. KHDSS was established in 2000 with an initial population of about 198,000 and covers an area of 891 Km². There are currently about 290,000 residents in its population register. Records of births, pregnancies, migrations and deaths among residents are updated by 4-monthly household visits, which enable an accurate track of denominators for estimating disease burden among the residents. Within the KHDSS area there is a single government referral hospital, Kilifi County Hospital (KCH). Approximately 55% of the children admitted at KCH are residents of KHDSS. At KCH, morbidity events are linked in real time to the population register through an integrated data management system. Since 2008 linked surveillance was extended to include KHDSS vaccine clinics for the purpose of monitoring vaccination coverage [141].

Using the KHDSS platform studies have generated detailed data on a wide range measures, including nasopharyngeal carriage and invasive pneumococcal disease from routine surveillance before and after vaccine introduction, that can be used to support mathematical models [20,69,140–142]. There are also complementary results from local epidemiological studies that provide information on duration of carriage, competitive strength of serotypes and rates of social contacts [20,143].

The report of the work in this thesis is presented in a research paper style structured into four research chapters with the following titles:

1. Sustained reduction in vaccine-type invasive pneumococcal disease despite waning effects of a catch-up campaign in Kilifi, Kenya: a mathematical model based on pre-vaccination data.

2. Pneumococcal conjugate vaccine induced IgG and nasopharyngeal carriage of pneumococci: Hyporesponsiveness and immune correlates of protection for carriage
3. Effect of maternally-derived anti-protein and anti-capsular IgG antibodies on the rate of acquisition of nasopharyngeal carriage of pneumococcus in newborns.
4. The merits of sustaining pneumococcal vaccination after transitioning from Gavi support – a cost-effectiveness study for Kenya

In research paper 1, I developed an age-structured dynamic transmission model of pneumococcal carriage calibrated with the detailed pre-vaccination data from KHDSS and used the post-vaccination data to validate its predictions. In Kilifi, unlike the rest of the country, PCV10 was introduced with a catch-up campaign in <5 year olds. Given the continued observation of vaccine serotypes in circulation, 5 years after PCV10 introduction [77], I also investigated if vaccine-serotype invasive pneumococcal disease may re-emerge once the effects of the under-5 year old catch-up campaign wear off.

Mathematical models can broadly be categorised as either agent-based or compartmental. In an agent-based model transition between states in the model is determined by the behaviour of the individual and not the group as a whole, as is the case with a compartmental model. One main advantage of a compartmental model is that it is computationally faster. Except for two models that are agent-based [136,138], published transmission-dynamic models of pneumococcal transmission to study vaccination impact are compartmental [74,75,137–139,144,145].

Pneumococcal transmission models invariably group hypothetical individuals according their pneumococcal carriage status where an individual can be completely susceptible,

carry single serotypes, or carry two serotypes simultaneously. In order to reproduce serotype replacement, the models almost always group serotypes into two broad categories, vaccine-serotypes and non-vaccine serotypes, and encode a mechanism of competition between these two serotype groups. Very few models have however considered more than two serotype groups [75,136,138].

The grouping of serotypes into aggregate types tackles the problem with a large number of serotypes for which individual characteristics might not be available. However, a key criticism of grouping of serotypes is that the aggregate types can have dynamics that are different than the individual serotypes included. The grouping of serotypes may also artificially promote their co-existence in the model because it artificially reduces serotype-specific fitness differences.

From the two pre-vaccination pneumococcal carriage surveys conducted in Kilifi, Kenya, the data that our model was fitted to, 46 different serotypes were detected in carriage [106]. A transmission model that accounts for the characteristics of each of these serotypes individually would be impractical; we do not have information on the duration of carriage of each of the serotypes circulating in Kilifi, also, some of them are rarely carried and thus occur in very low frequencies, which would lead to convergence problems in model fitting especially when the small numbers are further considered by age groups in an age-structured model. Some pooling of serotypes was necessary in the model used.

I pooled serotypes into three classes; vaccine-serotypes, strong non-vaccine serotypes and weak non-vaccine serotypes. The separation between weak and strong non-vaccine serotypes was based on prior information on the some of the serotypes susceptibility to competition. The reason why I did not split the vaccine serotypes into say two classes as

we did with the non-vaccine serotypes is because I intended the model to reproduce serotype replacement with a small number of competition parameters as possible, by limiting the number of compartments. The extent of serotype replacement would be more accurately predicted if the heterogeneity within non-vaccine serotypes, rather than those within vaccine-serotypes, is incorporated in the model. This is because heterogeneity in the non-vaccine serotypes is higher by virtue having a larger number of serotypes.

In the interests of parsimony, several aspects of pneumococcal immunology and epidemiology are simplified in the generation of this model. Two such simplifying assumptions are: (i) the immunogenicity of the vaccine is independent of the carriage status of the vaccinees; (ii) children are born completely susceptible to carriage acquisition with no protection from maternally acquired antibodies. In order to test the validity of these assumptions in Kilifi I undertook statistical modelling of data from prior studies in Kilifi examining the safety and immunogenicity of PCV, which also monitored carriage. These analyses form research papers 2 and 3 respectively and inform research paper 4.

For research paper 4, I used the model from research paper 1 but extended the fitting process to also include age stratified post-vaccination (2011-2016) pneumococcal carriage. I then use the model to predict the impact of continuing or discontinuing the PCV10 programme in 2022. On the basis of those predictions I assessed the cost-effectiveness of continuing with the PCV10 vaccination programme for 11 years from year 2022 relative to stopping the vaccination programme at that time.

In a final chapter I will integrate the results of the four discrete investigations to attempt to give an answer to the problems posed in the present chapter.

References

- [1] Henrichsen J. Six newly recognized types of *Streptococcus pneumoniae*. *J Clin Microbiol* 1995;33:2759–62.
- [2] Calix JJ, Porambo RJ, Brady AM, Larson TR, Yother J, Abeygunwardana C, et al. Biochemical, genetic, and serological characterization of two capsule subtypes among *Streptococcus pneumoniae* serotype 20 strains: Discovery of a new pneumococcal serotype. *J Biol Chem* 2012;287:27885–94. doi:10.1074/jbc.M112.380451.
- [3] Weinberger DM, Trzcinski K, Lu YJ, Bogaert D, Brandes A, Galagan J, et al. Pneumococcal capsular polysaccharide structure predicts serotype prevalence. *PLoS Pathog* 2009;5:e1000476. doi:10.1371/journal.ppat.1000476.
- [4] Geno KA, Gilbert GL, Song JY, Skovsted IC, Klugman KP, Jones C, et al. Pneumococcal capsules and their types: Past, present, and future. *Clin Microbiol Rev* 2015;28:871–99. doi:10.1128/CMR.00024-15.
- [5] Nelson AL, Roche AM, Gould JM, Chim K, Ratner AJ, Weiser JN. Capsule enhances pneumococcal colonization by limiting mucus-mediated clearance. *Infect Immun* 2007;75:83–90. doi:10.1128/IAI.01475-06.
- [6] Hammerschmidt S, Wolff S, Hocke A, Rosseau S, Müller E, Rohde M. Illustration of Pneumococcal Polysaccharide Capsule during Adherence and Invasion of Epithelial Cells Illustration of Pneumococcal Polysaccharide Capsule during Adherence and Invasion of Epithelial Cells. *Infect Immun* 2005;73:4653–67. doi:10.1128/IAI.73.8.4653.
- [7] Nel JG, Theron AJ, Durandt C, Tintinger GR, Pool R, Mitchell TJ, et al. Pneumolysin activates neutrophil extracellular trap formation. *Clin Exp Immunol* 2016;184:358–67. doi:10.1111/cei.12766.
- [8] Mirza S, Benjamin WH, Coan PA, Hwang SA, Winslett AK, Yother J, et al. The effects of differences in *pspA* alleles and capsular types on the resistance of *Streptococcus pneumoniae* to killing by apolactoferrin. *Microb Pathog* 2016;99:209–19. doi:10.1016/j.micpath.2016.08.029.
- [9] Plumptre CD, Hughes CE, Harvey RM, Eijkelkamp BA, McDevitt CA, Paton JC. Overlapping functionality of the *pht* proteins in zinc homeostasis of *Streptococcus pneumoniae*. *Infect Immun* 2014;82:4315–24. doi:10.1128/IAI.02155-14.
- [10] André GO, Politano WR, Mirza S, Converso TR, Ferraz LFC, Leite LCC, et al. Combined effects of lactoferrin and lysozyme on *Streptococcus pneumoniae* killing. *Microb Pathog* 2015;89:7–17. doi:10.1016/j.micpath.2015.08.008.
- [11] Voss S, Hallström T, Saleh M, Burchhardt G, Pribyl T, Singh B, et al. The choline-binding Protein PspC of *Streptococcus pneumoniae* interacts with the C-terminal heparin-binding domain of vitronectin. *J Biol Chem* 2013;288:15614–27. doi:10.1074/jbc.M112.443507.
- [12] Harada T, Ogawa Y, Eguchi M, Shi F, Sato M, Uchida K, et al. Phosphorylcholine and SpaA, a choline-binding protein, are involved in the adherence of *Erysipelothrix rhusiopathiae* to porcine endothelial cells, but this adherence is not mediated by the PAF receptor. *Vet Microbiol* 2014;172:216–22. doi:10.1016/j.vetmic.2014.04.012.
- [13] Verhoeven D, Xu Q, Pichichero ME. Vaccination with a *Streptococcus pneumoniae* trivalent recombinant PcpA, PhtD and PlyD1 protein vaccine candidate protects against lethal pneumonia in an infant murine model. *Vaccine* 2014;32:3205–10. doi:10.1016/j.vaccine.2014.04.004.

- [14] Harfouche C, Filippini S, Gianfaldoni C, Ruggiero P, Moschioni M, Maccari S, et al. RrgB321, a fusion protein of the three variants of the pneumococcal pilus backbone RrgB, is protective In Vivo and elicits opsonic antibodies. *Infect Immun* 2012;80:451–60. doi:10.1128/IAI.05780-11.
- [15] Xie X, Li Y, Zhang T, Fang HHP. Bacterial survival in evaporating deposited droplets on a teflon-coated surface. *Appl Microbiol Biotechnol* 2006;73:703–12. doi:10.1007/s00253-006-0492-5.
- [16] Walther B a, Ewald PW. Pathogen survival in the external environment and the evolution of virulence. *Biol Rev Camb Philos Soc* 2004;79:849–69. doi:10.1017/S1464793104006475.
- [17] Hamburger M, Green MJ. The problem of the dangerous carrier of hemolytic streptococci; observations upon the role of the hands, of blowing the nose, of sneezing, and of coughing in the dispersal of these microorganisms. *J Infect Dis* 1946;79:33–44.
- [18] Walsh RL, Camilli A. *Streptococcus pneumoniae* Is Desiccation Tolerant and Infectious upon Rehydration. *MBio* 2011;2:e00092-11. doi:10.1128/mBio.00092-11.
- [19] Auranen K, Mehtälä J, Tanskanen A, S Kalso M. Between-strain competition in acquisition and clearance of pneumococcal carriage--epidemiologic evidence from a longitudinal study of day-care children. *Am J Epidemiol* 2010;171:169–76. doi:10.1093/aje/kwp351.
- [20] Lipsitch M, Abdullahi O, D'amour A, Xie W, Weinberger DM, Tchetgen ET, et al. Estimating Rates of Carriage Acquisition and Clearance and Competitive Ability for Pneumococcal Serotypes in Kenya With a Markov Transition Model. *Epidemiology* 2012;23:1–10. doi:10.1097/EDE.0b013e31824f2f32.
- [21] Lipsitch M, Dykes JK, Johnson SE, Ades EW, King J, Briles DE, et al. Competition among *Streptococcus pneumoniae* for intranasal colonization in a mouse model. *Vaccine* 2000;18:2895–901.
- [22] Abdullahi O, Karani A, Tigoi CC, Mugo D, Kungu S, Wanjiru E, et al. Rates of acquisition and clearance of pneumococcal serotypes in the nasopharynx of children in Kilifi District, Kenya. *J Infect Dis* 2012;206:1020–9. doi:10.1093/infdis/jis447.
- [23] Melegaro A, Choi Y, Pebody R, Gay N. Pneumococcal carriage in United Kingdom families: estimating serotype-specific transmission parameters from longitudinal data. *Am J Epidemiol* 2007;166:228–35. doi:10.1093/aje/kwm076.
- [24] Hoti F, Erästö P, Leino T, Auranen K. Outbreaks of *Streptococcus pneumoniae* carriage in day care cohorts in Finland - implications for elimination of transmission. *BMC Infect Dis* 2009;9:102. doi:10.1186/1471-2334-9-102.
- [25] Zhang Q, Leong SC, McNamara PS, Mubarak A, Malley R, Finn A. Characterisation of regulatory t cells in nasal associated lymphoid tissue in children: Relationships with pneumococcal colonization. *PLoS Pathog* 2011;7. doi:10.1371/journal.ppat.1002175.
- [26] Lu Y-J, Gross J, Bogaert D, Finn A, Bagraade L, Zhang Q, et al. Interleukin-17A mediates acquired immunity to pneumococcal colonization. *PLoS Pathog* 2008;4:e1000159. doi:10.1371/journal.ppat.1000159.
- [27] Bogaert D, Weinberger D, Thompson C, Lipsitch M, Malley R. Impaired Innate and Adaptive Immunity to *Streptococcus pneumoniae* and Its Effect on Colonization in an Infant Mouse Model □. *Infect Immun* 2009;77:1613–22. doi:10.1128/IAI.00871-08.
- [28] Cobey S, Lipsitch M. Niche and neutral effects of acquired immunity permit coexistence of pneumococcal serotypes. *Science* 2012;335:1376–80. doi:10.1126/science.1215947.

- [29] Roche AM, Richard AL, Rahkola JT, Janoff EN, Weiser JN. Antibody blocks acquisition of bacterial colonization through agglutination. *Mucosal Immunol* 2015;8:176–85. doi:10.1038/mi.2014.55.
- [30] Zangari T, Wang Y, Weiser JN. Streptococcus pneumoniae Transmission Is Blocked by Type-Specific Immunity in an Infant Mouse Model. *MBio* 2017;8:e00188-17. doi:10.1128/mBio.00188-17.
- [31] Goldblatt D, Hussain M, Andrews N, Ashton L, Virta C, Melegaro A, et al. Antibody responses to nasopharyngeal carriage of Streptococcus pneumoniae in adults: a longitudinal household study. *J Infect Dis* 2005;192:387–93. doi:10.1086/431524.
- [32] Granat SM, Ollgren J, Herva E, Mia Z, Auranen K, Mäkelä PH. Epidemiological evidence for serotype-independent acquired immunity to pneumococcal carriage. *J Infect Dis* 2009;200:99–106. doi:10.1086/599364.
- [33] Lebon A, Verkaik NJ, Labout J a M, de Vogel CP, Hooijkaas H, Verbrugh H a., et al. Natural antibodies against several pneumococcal virulence proteins in children during the pre-pneumococcal-vaccine era: The generation R study. *Infect Immun* 2011;79:1680–7. doi:10.1128/IAI.01379-10.
- [34] Brien KLO, Wolfson LJ, Watt JP, Henkle E, Deloria-knoll M, Mccall N, et al. Burden of disease caused by Streptococcus pneumoniae in children younger than 5 years : global estimates. *Lancet* 2009;374:893–902. doi:10.1016/S0140-6736(09)61204-6.
- [35] Fedson DS, Scott J a, Scott G. The burden of pneumococcal disease among adults in developed and developing countries: what is and is not known. *Vaccine* 1999;17 Suppl 1:S11-8. doi:10.1016/S0264-410X(99)00122-X.
- [36] Estimated Hib and pneumococcal deaths for children under 5 years of age, 2008. WHO 2013. http://www.who.int/immunization/monitoring_surveillance/burden/estimates/Pneumo_hib/en/ (accessed September 18, 2017).
- [37] The Evidence Base for Pneumococcal Conjugate Vaccines: Data for decision-making around PCV use in childhood. 2017.
- [38] Holmlund E, Quiambao B, Ollgren J, Nohynek H, Käyhty H. Development of natural antibodies to pneumococcal surface protein A, pneumococcal surface adhesin A and pneumolysin in Filipino pregnant women and their infants in relation to pneumococcal carriage. *Vaccine* 2006;24:57–65. doi:10.1016/j.vaccine.2005.07.055.
- [39] Palmeira P, Quinello C, Ana L, Zago A, Carneiro-sampaio M. IgG Placental Transfer in Healthy and Pathological Pregnancies Cl ´. *Clin Dev Immunol* 2012;2012. doi:10.1155/2012/985646.
- [40] Simell B, Auranen K, Käyhty H, Goldblatt D, Dagan R, O'Brien KL, et al. The fundamental link between pneumococcal carriage and disease. *Expert Rev Vaccines* 2012;11:841–55. doi:10.1586/erv.12.53.
- [41] Francis JP, Richmond PC, Pomat WS, Michael A, Keno H, Phuanukoonnon S, et al. Maternal antibodies to pneumolysin but not to pneumococcal surface protein a delay early pneumococcal carriage in high-risk Papua New Guinean infants. *Clin Vaccine Immunol* 2009;16:1633–8. doi:10.1128/CVI.00247-09.
- [42] Lopes CRC, Berezin EN, Ching TH, Canuto JDS, Costa VO Da, Klering EM. Ineffectiveness for infants of immunization of mothers with pneumococcal capsular polysaccharide vaccine during pregnancy. *Braz J Infect Dis* 2009;13:104–6. doi:S1413-86702009000200006 [pii] ET - 2010/02/09.
- [43] Munoz FM, Englund J a, Cheesman CC, Maccato ML, Pinell PM, Nahm MH, et al. Maternal immunization with pneumococcal polysaccharide vaccine in the third trimester of gestation. *Vaccine* 2001;20:826–37. doi:http://dx.doi.org/10.1016/S0264-410X(01)00397-8.

- [44] Rosen A, Håkansson A, Aniansson G, Hansson C, Andersson B, Nylén O, et al. Antibodies to pneumococcal polysaccharides in human milk: lack of relationship to colonization and acute otitis media. *Pediatr Infect Dis J* 1996;15:498–507.
- [45] Lopes CC, Berezin EN, Scheffer D, Huziwara R, Sliva MI, Brandao a., et al. Pneumococcal Nasopharyngeal Carriage in Infants of Mothers Immunized with 23V Non-conjugate Pneumococcal Polysaccharide Vaccine. *J Trop Pediatr* 2012;58:348–52. doi:10.1093/tropej/fmr107.
- [46] Turner P, Turner C, Green N, Ashton L, Lwe E, Jankhot a, et al. Serum antibody responses to pneumococcal colonization in the first 2 years of life: results from an SE Asian longitudinal cohort study. *Clin Microbiol Infect* 2013;19:E551-8. doi:10.1111/1469-0691.12431.
- [47] Douglas RM, Paton JC, Duncan SJ, Hansman DJ. Antibody response to pneumococcal vaccination in children younger than five years of age. *J Infect Dis* 1983;148:131–7.
- [48] Leinonen M, Säkkinen A, Kalliokoski R, Luotonen J, Timonen M, Mäkelä PH. Antibody response to 14-valent pneumococcal capsular polysaccharide vaccine in pre-school age children. *Pediatr Infect Dis* 1986;5:39–44.
- [49] Bondada S, Wu HJ, Robertson DA, Chelvarajan RL. Accessory cell defect in unresponsiveness of neonates and aged to polysaccharide vaccines. *Vaccine* 2000;19:557–65. doi:10.1016/S0264-410X(00)00161-4.
- [50] Mitchell R, Kelly DF, Pollard AJ, Trück J. Polysaccharide-specific B cell responses to vaccination in humans. *Hum Vaccines Immunother* 2014;10:1661–8. doi:10.4161/hv.28350.
- [51] Klein Klouwenberg P, Bont L. Neonatal and infantile immune responses to encapsulated bacteria and conjugate vaccines. *Clin Dev Immunol* 2008;2008. doi:10.1155/2008/628963.
- [52] Martin F, Kearney JF. MARGINAL-ZONE B CELLS. *Nat Rev Immunol* 2002;2:323–35. doi:10.1038/nri799.
- [53] Bjarnarson SP, Benonisson H, Del Giudice G, Jonsdottir I. Pneumococcal polysaccharide abrogates conjugate-induced germinal center reaction and depletes antibody secreting cell pool, causing hyporesponsiveness. *PLoS One* 2013;8:e72588. doi:10.1371/journal.pone.0072588.
- [54] Papadatou I, Orthopoulos G, Theodoridou M, Spoulou V. Long-lasting hyporesponsiveness induced by the 23-valent pneumococcal polysaccharide vaccine (PPV23) in asplenic patients with β -thalassemia major. *Vaccine* 2015;33:3779–83. doi:10.1016/j.vaccine.2015.06.100.
- [55] Hammit LL, Bulkow LR, Singleton RJ, Nuorti JP, Hummel KB, Miernyk KM, et al. Repeat revaccination with 23-valent pneumococcal polysaccharide vaccine among adults aged 55-74 years living in Alaska: no evidence of hyporesponsiveness. *Vaccine* 2011;29:2287–95. doi:10.1016/j.vaccine.2011.01.029.
- [56] Grabenstein JD, Manoff SB. Pneumococcal polysaccharide 23-valent vaccine: Long-term persistence of circulating antibody and immunogenicity and safety after revaccination in adults. *Vaccine* 2012;30:4435–44. doi:10.1016/j.vaccine.2012.04.052.
- [57] Herva E, Luotonen J, Timonen M, Sibakov M, Karma P, Mäkelä PH. The effect of polyvalent pneumococcal polysaccharide vaccine on nasopharyngeal and nasal carriage of *Streptococcus pneumoniae*. *Scand J Infect Dis* 1980;12:97–100.
- [58] Russell FM, Carapetis JR, Satzke C, Tikoduadua L, Waqatakirewa L, Chandra R, et al. Pneumococcal nasopharyngeal carriage following reduced doses of a 7-valent pneumococcal conjugate vaccine and a 23-valent pneumococcal polysaccharide

- vaccine booster. *Clin Vaccine Immunol* 2010;17:1970–6. doi:10.1128/CVI.00117-10.
- [59] Macleod BYCM, Hodges RG, Heidelberger M, Bernhard AWG. Prevention of Pneumococcal Pneumonia by Immunization with specific capsular polysaccharides. *J Exp Med* 1945;82:445–65.
- [60] Avery OT, Goebel WF. Chemo-immunological studies on conjugated carbohydrate-proteins. *J Exp Med* 1931;54:437–47.
- [61] Stanley A P, Robert S D, G. Scott G, Caroline B H, Martha L, Edgar K M, et al. Haemophilus Vaccine influenzae Type b Conjugate. *Pediatrics* 1988;81:908–11.
- [62] Pichichero ME. Protein carriers of conjugate vaccines: characteristics, development, and clinical trials. *Hum Vaccin Immunother* 2013;9:2505–23. doi:10.4161/hv.26109.
- [63] Mccool TL, Harding C V., Greenspan NS, Schreiber JR. B- and T-cell immune responses to pneumococcal conjugate vaccines: Divergence between carrier- and polysaccharide-specific immunogenicity. *Infect Immun* 1999;67:4862–9.
- [64] Gonçalves VM, Dias WO, Campos IB, Liberman C, Sbrogio-Almeida ME, Silva EP, et al. Development of a whole cell pneumococcal vaccine: BPL inactivation, cGMP production, and stability. *Vaccine* 2014;32:1113–20. doi:10.1016/j.vaccine.2013.10.091.
- [65] Moffitt KL, Malley R. Next generation pneumococcal vaccines. *Curr Opin Immunol* 2011;23:407–13. doi:10.1016/j.coi.2011.04.002.
- [66] Feldman C, Anderson R. Review: Current and new generation pneumococcal vaccines. *J Infect* 2014;69:309–25. doi:10.1016/j.jinf.2014.06.006.
- [67] Dagan R, Givon-Lavi N, Zamir O, Sikuler-Cohen M, Guy L, Janco J, et al. Reduction of nasopharyngeal carriage of Streptococcus pneumoniae after administration of a 9-valent pneumococcal conjugate vaccine to toddlers attending day care centers. *J Infect Dis* 2002;185:927–36.
- [68] Dagan R, Muallem M, Melamed R, Leroy O, Yagupsky P. Reduction of pneumococcal nasopharyngeal carriage in early infancy after immunization with tetravalent pneumococcal vaccines conjugated to either tetanus toxoid or diphtheria toxoid. *Pediatr Infect Dis* 1997;16:1060–4.
- [69] Hammitt LL, Ojal J, Bashraheil M, Morpeth SC, Karani A, Habib A, et al. Immunogenicity, Impact on Carriage and Reactogenicity of 10-Valent Pneumococcal Non-Typeable Haemophilus influenzae Protein D Conjugate Vaccine in Kenyan Children Aged 1-4 Years: A Randomized Controlled Trial. *PLoS One* 2014;9:e85459. doi:10.1371/journal.pone.0085459.
- [70] Le Polain O, Flasche S, Prieto-Merino D, Goldblatt D, Edmunds WJ. The Efficacy and Duration of Protection of Pneumococcal Conjugate Vaccines Against Nasopharyngeal Carriage. *Pediatr Infect Dis J* 2015;34:858–64. doi:10.1097/INF.0000000000000717.
- [71] Davis SM, Deloria-Knoll M, Kassa HT, O'Brien KL. Impact of pneumococcal conjugate vaccines on nasopharyngeal carriage and invasive disease among unvaccinated people: Review of evidence on indirect effects. *Vaccine* 2013;32:133–45. doi:10.1016/j.vaccine.2013.05.005.
- [72] Miller E, Andrews NJ, Waight P a, Slack MP, George RC. Herd immunity and serotype replacement 4 years after seven-valent pneumococcal conjugate vaccination in England and Wales: an observational cohort study. *Lancet Infect Dis* 2011;11:760–8. doi:10.1016/S1473-3099(11)70090-1.
- [73] Gladstone RA, Jefferies JM, Tocheva AS, Beard KR, Garley D, Wei W, et al. Five winters of pneumococcal serotype replacement in UK carriage following PCV introduction. *Vaccine* 2015;33:2015–21.
- [74] Choi YH, Jit M, Gay N, Andrews N, Waight P a, Melegaro A, et al. 7-Valent

pneumococcal conjugate vaccination in England and Wales: is it still beneficial despite high levels of serotype replacement? *PLoS One* 2011;6:e26190. doi:10.1371/journal.pone.0026190.

- [75] Bottomley C, Roca A, Hill PC, Greenwood B, Isham V. A mathematical model of serotype replacement in pneumococcal carriage following vaccination. *J R Soc Interface* 2013;10.
- [76] Lipsitch M. Bacterial vaccines and serotype replacement: lessons from *Haemophilus influenzae* and prospects for *Streptococcus pneumoniae*. *Emerg Infect Dis* 1999;5:336–45.
- [77] Hammitt LL, Akech DO, Morpeth SC, Karani A, Nyongesa S, Ooko M, et al. Population impact of 10-valent pneumococcal conjugate vaccine (PCV) on nasopharyngeal carriage of *Streptococcus pneumoniae* in Kilifi, Kenya. 10th Int. Symp. Pneumococci Pneumococcal Dis., Glasgow, Scotland.: 2016.
- [78] Roca A, Bojang A, Bottomley C, Gladstone RA, Adetifa JU, Egere U, et al. Effect on nasopharyngeal pneumococcal carriage of replacing PCV7 with PCV13 in the Expanded Programme of Immunization in The Gambia. *Vaccine* 2015;33:7144–51. doi:10.1016/j.vaccine.2015.11.012.
- [79] O'Brien K, Moulton L, Reid R, Weatherholtz R, Oski J, Brown L, et al. Efficacy, safety and immunogenicity of heptavalent pneumococcal conjugate vaccine in children. Northern California Kaiser Permanente Vaccine Study Center Group. *Pediatr Infect Dis J* 2000;19:187–95.
- [80] O'Brien K, Moulton L, Reid R, Weatherholtz R, Oski J, Brown L, et al. Efficacy and safety of seven-valent conjugate pneumococcal vaccine in American Indian children: group randomised trial. *Lancet* 2003;362:355–61.
- [81] Segal N, Greenberg D, Dagan R, Ben-Shimol S. Disparities in PCV impact between different ethnic populations cohabiting in the same region: A systematic review of the literature. *Vaccine* 2016;34:4371–7. doi:10.1016/j.vaccine.2016.07.004.
- [82] Fitzwater SP, Chandran A, Santosham M, Johnson HL. The worldwide impact of the seven-valent pneumococcal conjugate vaccine. *Pediatr Infect Dis J* 2012;31:501–8. doi:10.1097/INF.0b013e31824de9f6.
- [83] Madhi SA, Nunes MC. The potential impact of pneumococcal conjugate vaccine in Africa: Considerations and early lessons learned from the South African experience. *Hum Vaccin Immunother* 2016;12:314–25. doi:10.1080/21645515.2015.1084450.
- [84] De Oliveira LH, Camacho LAB, Coutinho ESF, Martinez-Silveira MS, Carvalho AF, Ruiz-Matus C, et al. Impact and effectiveness of 10 and 13-valent pneumococcal conjugate vaccines on hospitalization and mortality in children aged less than 5 years in Latin American countries: A systematic review. *PLoS One* 2016;11:1–25. doi:10.1371/journal.pone.0166736.
- [85] Lucero MG, Nohynek H, Williams G, Tallo V, Simões E a F, Lupisan S, et al. Efficacy of an 11-valent pneumococcal conjugate vaccine against radiologically confirmed pneumonia among children less than 2 years of age in the Philippines: a randomized, double-blind, placebo-controlled trial. *Pediatr Infect Dis J* 2009;28:455–62. doi:10.1097/INF.0b013e31819637af.
- [86] Myint TTH, Madhava H, Balmer P, Christopoulou D, Attal S, Menegas D, et al. The impact of 7-valent pneumococcal conjugate vaccine on invasive pneumococcal disease: A literature review. *Adv Ther* 2013;30:127–51. doi:10.1007/s12325-013-0007-6.
- [87] Lucero MG, Dulalia VE, Nillos LT, Williams G, Parreño RAN, Nohynek H, et al. Pneumococcal conjugate vaccines for preventing vaccine-type invasive pneumococcal disease and X-ray defined pneumonia in children less than two years

- of age (Review). Cochrane Database Sytematic Rev 2009 2010;CD004977.
- [88] Singleton RJ, Hennessy TW, Bulkow LR, Hammitt LL, Zulz T, Hurlburt DA, et al. Invasive Pneumococcal Disease Caused by Nonvaccine Serotypes Among Alaska Native Pneumococcal Conjugate Vaccine Coverage. *JAMA* 2007;297:1784–92.
- [89] Jokinen J, Rinta-Kokko H, Siira L, Palmu AA, Virtanen MJ, Nohynek H, et al. Impact of ten-valent pneumococcal conjugate vaccination on invasive pneumococcal disease in Finnish children - A population-based study. *PLoS One* 2015;10:1–11. doi:10.1371/journal.pone.0120290.
- [90] Roca A, Hill PC, Townend J, Egere U, Antonio M, Bojang A, et al. Effects of Community-Wide Vaccination with PCV-7 on Pneumococcal Nasopharyngeal Carriage in The Gambia: A Cluster-Randomized Trial. *PLoS Med* 2011;8:e1001107. doi:10.1371/journal.pmed.1001107.
- [91] Nhantumbo AA, Weldegebriel G, Katsande R, De Gouveia L, Comé CE, Cuco AZ, et al. Surveillance of impact of PCV-10 vaccine on pneumococcal meningitis in Mozambique, 2013 - 2015. *PLoS One* 2017;12:2013–5. doi:10.1371/journal.pone.0177746.
- [92] von Mollendorf C, Tempia S, von Gottberg A, Meiring S, Quan V, Feldman C, et al. Estimated severe pneumococcal disease cases and deaths before and after pneumococcal conjugate vaccine introduction in children younger than 5 years of age in South Africa. *PLoS One* 2017;12:e0179905. doi:10.1371/journal.pone.0179905.
- [93] Cutts FT, Zaman SMA, Enwere G, Jaffar S, Levine OS, Okoko JB, et al. Efficacy of nine-valent pneumococcal conjugate vaccine against pneumonia and invasive pneumococcal disease in The Gambia: randomised, double-blind, placebo-controlled trial. *Lancet* 2005;365:1139–46. doi:10.1016/S0140-6736(05)71876-6.
- [94] Klugman KP, Madhi SA, Huebner RE, Kohberger R, Mbelle N, Pierce N. A trial of a 9-valent pneumococcal conjugate vaccine in children with and those without HIV infection. *N Engl J Med* 2003;349:1341–8. doi:10.1056/NEJMoa035060.
- [95] Shea KM, Weycker D, Stevenson a E, Strutton DR, Pelton SI. Modeling the decline in pneumococcal acute otitis media following the introduction of pneumococcal conjugate vaccines in the US. *Vaccine* 2011;29:8042–8. doi:10.1016/j.vaccine.2011.08.057.
- [96] Lau WCY, Murray M, El-turki A, Saxena S, Ladhani S, Long P, et al. Impact of pneumococcal conjugate vaccines on childhood otitis media in the United Kingdom. *Vaccine* 2015;33:5072–9. doi:10.1016/j.vaccine.2015.08.022.
- [97] Littorin N, Ahl J, Uddén F, Resman F, Riesbeck K. Reduction of *Streptococcus pneumoniae* in upper respiratory tract cultures and a decreased incidence of related acute otitis media following introduction of childhood pneumococcal conjugate vaccines in a Swedish county. *BMC Infect Dis* 2016;16:407. doi:10.1186/s12879-016-1750-5.
- [98] Ben-shimol S, Givon-lavi N, Leibovitz E, Raiz S, Greenberg D, Dagan R. Impact of Widespread Introduction of Pneumococcal Conjugate Vaccines on Pneumococcal and Nonpneumococcal Otitis Media. *Clin Infect Dis* 2016;63:611–8. doi:10.1093/cid/ciw347.
- [99] Madhi SA, Adrian P, Kuwanda L, Jassat W, Jones S, Little T, et al. Long-term immunogenicity and efficacy of a 9-valent conjugate pneumococcal vaccine in human immunodeficient virus infected and non-infected children in the absence of a booster dose of vaccine. *Vaccine* 2007;25:2451–7. doi:10.1016/j.vaccine.2006.09.019.
- [100] Madhi SA, Klugman KP. World Health Organisation definition of “radiologically-

confirmed pneumonia” may under-estimate the true public health value of conjugate pneumococcal vaccines. *Vaccine* 2007;25:2413–9. doi:10.1016/j.vaccine.2006.09.010.

- [101] Rosenblut A, Napolitano C, Pereira A, Moreno C, Kolhe D, Lepetic A, et al. Etiology of acute otitis media and serotype distribution of *Streptococcus pneumoniae* and *Haemophilus influenzae* in Chilean children <5 years of age. *Medicine (Baltimore)* 2017;96:e5974. doi:10.1097/MD.0000000000005974.
- [102] Buzatto GP, Tamashiro E, Proenca-Modena JL, Saturno TH, Prates MC, Gagliardi TB, et al. The pathogens profile in children with otitis media with effusion and adenoid hypertrophy. *PLoS One* 2017;12:1–12. doi:10.1371/journal.pone.0171049.
- [103] von Gottberg A, de Gouveia L, Tempia S, Quan V, Meiring S, von Mollendorf C, et al. Effects of Vaccination on Invasive Pneumococcal Disease in South Africa. *N Engl J Med* 2014;371:141111140010002. doi:10.1056/NEJMoa1401914.
- [104] Mackenzie GA, Hill PC, Sahito SM, Jeffries DJ, Hossain I, Bottomley C, et al. Impact of the introduction of pneumococcal conjugate vaccination on pneumonia in The Gambia : population-based surveillance and case-control studies. *Lancet Infect Dis* 2017:1–9. doi:10.1016/S1473-3099(17)30321-3.
- [105] Mackenzie GA, Hill PC, Jeffries DJ, Hossain I, Uchendu U, Ameh D, et al. Effect of the introduction of pneumococcal conjugate vaccination on invasive pneumococcal disease in The Gambia: A population-based surveillance study. *Lancet Infect Dis* 2016:703–11. doi:10.1016/S1473-3099(16)00054-2.
- [106] Hammitt LL, Akech DO, Morpeth SC, Karani A, Kihuha N, Nyongesa S, et al. Population effect of 10-valent pneumococcal conjugate vaccine on nasopharyngeal carriage of *Streptococcus pneumoniae* and non-typeable *Haemophilus influenzae* in Kilifi, Kenya: findings from cross-sectional carriage studies. *Lancet Glob Heal* 2014:8–10. doi:10.1016/S2214-109X(14)70224-4.
- [107] Hammitt LL, Anthony E, Morpeth SC, Mutuku A, Ojal J, Mturi N, et al. Population effect of 10-valent pneumococcal conjugate vaccine on invasive pneumococcal disease and nasopharyngeal carriage in Kilifi, Kenya. *Manuscr Prep* 2017.
- [108] Silaba M, Ooko M, Bottomley C, Sande J, Benamore R, Park K, et al. The impact of 10-valent Pneumococcal Conjugate Vaccine on the incidence of radiologically-confirmed pneumonia and on clinically-defined pneumonia among children in Kilifi, Kenya. *Manuscr Prep* n.d.
- [109] Siber GR, Chang I, Baker S, Fernsten P, O’Brien KL, Santosham M, et al. Estimating the protective concentration of anti-pneumococcal capsular polysaccharide antibodies. *Vaccine* 2007;25:3816–26. doi:10.1016/j.vaccine.2007.01.119.
- [110] Millar E V, O’Brien KL, Bronsdon M a, Madore D, Hackell JG, Reid R, et al. Anticapsular serum antibody concentration and protection against pneumococcal colonization among children vaccinated with 7-valent pneumococcal conjugate vaccine. *Clin Infect Dis* 2007;44:1173–9. doi:10.1086/513199.
- [111] Dagan R, Juergens C, Trammel J, Patterson S, Greenberg D, Givon-Lavi N, et al. Modeling pneumococcal nasopharyngeal acquisition as a function of anticapsular serum antibody concentrations after pneumococcal conjugate vaccine administration. *Vaccine* 2016;34:4313–20. doi:10.1016/j.vaccine.2016.06.075.
- [112] Jódar L, Butler J, Carlone G, Dagan R, Goldblatt D, Käyhty H, et al. Serological criteria for evaluation and licensure of new pneumococcal conjugate vaccine formulations for use in infants. *Vaccine* 2003;21:3265–72. doi:10.1016/S0264-410X(03)00230-5.
- [113] Principi N, Esposito S. Serological criteria and carriage measurement for evaluation

- of new pneumococcal vaccines. *Hum Vaccines Immunother* 2015;11:1494–500. doi:10.1080/21645515.2015.1033600.
- [114] Andrews NJ, Waight PA, Burbidge P, Pearce E, Roalfe L, Zancolli M, et al. Serotype-specific effectiveness and correlates of protection for the 13-valent pneumococcal conjugate vaccine: A postlicensure indirect cohort study. *Lancet Infect Dis* 2014;14:839–46. doi:10.1016/S1473-3099(14)70822-9.
- [115] Flasche S, Van Hoek AJ, Goldblatt D, Edmunds WJ, O'Brien KL, Scott JAG, et al. The Potential for Reducing the Number of Pneumococcal Conjugate Vaccine Doses While Sustaining Herd Immunity in High-Income Countries. *PLoS Med* 2015;12:1–5. doi:10.1371/journal.pmed.1001839.
- [116] Borrow R, Stanford E, Waight P, Helbert M, Balmer P, Warrington R, et al. Serotype-specific immune unresponsiveness to pneumococcal conjugate vaccine following invasive pneumococcal disease. *Infect Immun* 2008;76:5305–9. doi:10.1128/IAI.00796-08.
- [117] Poolman J, Borrow R. Hyporesponsiveness and its clinical implications after vaccination with polysaccharide or glycoconjugate vaccines. *Expert Rev Vaccines* 2011;10:307–22. doi:10.1586/erv.11.8.
- [118] Väkeväinen M, Soininen A, Lucero M, Nohynek H, Auranen K, Mäkelä PH, et al. Serotype-specific hyporesponsiveness to pneumococcal conjugate vaccine in infants carrying pneumococcus at the time of vaccination. *J Pediatr* 2010;157:778–83.e1. doi:10.1016/j.jpeds.2010.04.071.
- [119] Dagan R, Givon-Lavi N, Greenberg D, Fritzell B, Siegrist C-A. Nasopharyngeal carriage of *Streptococcus pneumoniae* shortly before vaccination with a pneumococcal conjugate vaccine causes serotype-specific hyporesponsiveness in early infancy. *J Infect Dis* 2010;201:1570–9. doi:10.1086/652006.
- [120] Tamura K, Matsubara K, Ishiwada N, Nishi J, Ohnishi H, Suga S, et al. Hyporesponsiveness to the infecting serotype after vaccination of children with seven-valent pneumococcal conjugate vaccine following invasive pneumococcal disease. *Vaccine* 2014;32:1444–50. doi:10.1016/j.vaccine.2014.01.031.
- [121] Sigurdardottir ST, Center KJ, Davidsdottir K, Arason VA, Hjalmarsson B, Elisdottir R, et al. Decreased immune response to pneumococcal conjugate vaccine after 23-valent pneumococcal polysaccharide vaccine in children. *Vaccine* 2014;32:417–24. doi:10.1016/j.vaccine.2013.11.029.
- [122] Mbelle N, Huebner RE, Wasas a D, Kimura a, Chang I, Klugman KP. Immunogenicity and impact on nasopharyngeal carriage of a nonavalent pneumococcal conjugate vaccine. *J Infect Dis* 1999;180:1171–6. doi:10.1086/315009.
- [123] Obaro SK, Adegbola R a, Chang I, Banya W a, Jaffar S, Mcadam KW, et al. Safety and immunogenicity of a nonavalent pneumococcal vaccine conjugated to CRM197 administered simultaneously but in a separate syringe with diphtheria, tetanus and pertussis vaccines in Gambian infants. *Pediatr Infect Dis J* 2000;19:463–9.
- [124] Nurkka a, Ahman H, Korkeila M, Jäntti V, Käyhty H, Eskola J. Serum and salivary anti-capsular antibodies in infants and children immunized with the heptavalent pneumococcal conjugate vaccine. *Pediatr Infect Dis J* 2001;20:25–33. doi:10.1097/00006454-200101000-00006.
- [125] Hill PC, Cheung YB, Akisanya A, Sankareh K, Lahai G, Greenwood BM, et al. Nasopharyngeal carriage of *Streptococcus pneumoniae* in Gambian infants: a longitudinal study. *Clin Infect Dis* 2008;46:807–14. doi:10.1086/528688.
- [126] Tigoï CC, Gatakaa H, Karani A, Mugo D, Kungu S, Wanjiru E, et al. Rates of acquisition of pneumococcal colonization and transmission probabilities, by

- serotype, among newborn infants in Kilifi District, Kenya. *Clin Infect Dis* 2012;55:180–8. doi:10.1093/cid/cis371.
- [127] VFC | 2001-04-06 CDC Vaccine Price List 2001. <https://www.cdc.gov/vaccines/programs/vfc/awardees/vaccine-management/price-list/2001/2001-04-06.html> (accessed August 21, 2017).
- [128] VFC | 03-12-2010 CDC Vaccine Price List 2010. <https://www.cdc.gov/vaccines/programs/vfc/awardees/vaccine-management/price-list/2010/2010-03-12.html> (accessed August 21, 2017).
- [129] de Oliveira LH, Trumbo SP, Matus CR, Sanwogou NJ, Toscano CM. Pneumococcal conjugate vaccine introduction in Latin America and the Caribbean: progress and lessons learned. *Expert Rev Vaccines* 2016;1–10. doi:10.1586/14760584.2016.1166961.
- [130] About the Pan American Health Organization (PAHO). PAHO 2016. http://www.paho.org/hq/index.php?option=com_content&view=article&id=91&Itemid=220&lang=en (accessed August 23, 2017).
- [131] Revolving Fund Prices. PAHO 2017. http://www.paho.org/hq/index.php?option=com_content&view=article&id=9561%3A2014-revolving-fund-prices&catid=839%3Arevolving-fund&Itemid=40714&lang=en (accessed August 23, 2017).
- [132] How the pneumococcal AMC works - Gavi, the Vaccine Alliance n.d. <http://www.gavi.org/funding/pneumococcal-amc/how-the-pneumococcal-amc-works/> (accessed March 24, 2017).
- [133] Countries approved for support - Gavi, the Vaccine Alliance 2014. <http://www.gavi.org/results/countries-approved-for-support/> (accessed January 20, 2015).
- [134] Transition process - Gavi, the Vaccine Alliance n.d. <http://www.gavi.org/support/sustainability/transition-process/> (accessed July 10, 2017).
- [135] Kenya : Gavi support documents - Proposals, reports, plans, decision letters n.d. <http://www.gavi.org/country/kenya/documents/> (accessed March 24, 2017).
- [136] Nurhonen M, Cheng AC, Auranen K. Pneumococcal transmission and disease in silico: a microsimulation model of the indirect effects of vaccination. *PLoS One* 2013;8:e56079. doi:10.1371/journal.pone.0056079.
- [137] Van Effelterre T, Moore MR, Fierens F, Whitney CG, White L, Pelton SI, et al. A dynamic model of pneumococcal infection in the United States: implications for prevention through vaccination. *Vaccine* 2010;28:3650–60. doi:10.1016/j.vaccine.2010.03.030.
- [138] Choi YH, Jit M, Flasche S, Gay N, Miller E. Mathematical modelling long-term effects of replacing Prevnar7 with Prevnar13 on invasive pneumococcal diseases in England and Wales. *PLoS One* 2012;7:e39927. doi:10.1371/journal.pone.0039927.
- [139] Snedecor SJ, Strutton DR, Ciuryla V, Schwartz EJ, Botteman MF. Transmission-dynamic model to capture the indirect effects of infant vaccination with Prevnar (7-valent pneumococcal conjugate vaccine (PCV7)) in older populations. *Vaccine* 2009;27:4694–703. doi:10.1016/j.vaccine.2009.05.062.
- [140] Scott JAG, Bauni E, Moisi JC, Ojal J, Gatakaa H, Nyundo C, et al. Profile: The Kilifi Health and Demographic Surveillance System (KHDSS). *Int J Epidemiol* 2012;41:650–7. doi:10.1093/ije/dys062.
- [141] Adetifa IMO, Bwanaali T, Wafula J, Mutuku A, Karia B, Makumi A, et al. Cohort Profile: The Kilifi Vaccine Monitoring Study. *Int J Epidemiol* 2016:dyw202. doi:10.1093/ije/dyw202.

- [142] Etyang AO, Munge K, Bunyasi EW, Matata L, Ndila C, Kapesa S, et al. Burden of disease in adults admitted to hospital in a rural region of coastal Kenya: An analysis of data from linked clinical and demographic surveillance systems. *Lancet Glob Heal* 2014;2:216–24. doi:10.1016/S2214-109X(14)70023-3.
- [143] Kiti MC, Kinyanjui TM, Koech DC, Munywoki PK, Medley GF, Nokes DJ. Quantifying age-related rates of social contact using diaries in a rural coastal population of Kenya. *PLoS One* 2014;9:e104786. doi:10.1371/journal.pone.0104786.
- [144] Flasche S, Ojal J, Le O, Waroux P De, Otiende M, Brien KLO, et al. Assessing the efficiency of catch-up campaigns for the introduction of pneumococcal conjugate vaccine : a modelling study based on data from PCV10 introduction in Kilifi , Kenya. *BMC Med* 2017;15:1–10. doi:10.1186/s12916-017-0882-9.
- [145] Melegaro A, Choi YH, George R, Edmunds WJ, Miller E, Gay NJ. Dynamic models of pneumococcal carriage and the impact of the Heptavalent Pneumococcal Conjugate Vaccine on invasive pneumococcal disease. *BMC Infect Dis* 2010;10:90. doi:10.1186/1471-2334-10-90.
- [146] Colijn C, Cohen T, Hanage WP, Fraser C, Coexistence N, Link C. No coexistence for free : Neutral null models for multistrain pathogens. *Epidemics* 2009;1:2–13. doi:10.1016/j.epidem.2008.07.001.

Chapter 2: Research paper 1

Title: Sustained reduction in vaccine-type invasive pneumococcal disease despite waning effects of a catch-up campaign in Kilifi, Kenya: a mathematical model based on pre-vaccination data.

Author(s): John Ojal, Stefan Flasche, Laura L. Hammitt, Donald Akech, Moses C. Kiti, Tatu Kamau, Ifedayo Adetifa, Markku Nurhonen, J. Anthony G. Scott, Kari Auranen

Journal/Publisher: Vaccine, 2017 Aug 16; 35(35 Pt B): 4561-4568

Type of publication: Original contribution

Stage of publication: In press

Academic peer-reviewed: Yes

Copyright: Open access

Candidate's role:

I conceived the study. I developed the mathematical transmission model and implemented it in the R software to generate all the results presented in the manuscript. I wrote the first draft of the manuscript, reviewed and responded to all comments from co-authors as well as those from journal reviewers to generate the published manuscript.

Candidate's signature: 

Supervisor or senior author's signature to confirm Candidates role:

Sustained reduction in vaccine-type invasive pneumococcal disease despite waning effects of a catch-up campaign in Kilifi, Kenya: a mathematical model based on pre-vaccination data.

John Ojal^{1,3}, Stefan Flasche³, Laura L. Hammitt^{1,2}, Donald Akech¹, Moses C. Kiti¹, Tatu Kamau⁴, Ifedayo Adetifa^{1,3}, Markku Nurhonen⁵, J. Anthony G. Scott^{1,3}, Kari Auranen^{5,6}

1. KEMRI-Wellcome Trust Research Programme, Centre for Geographic Medicine-Coast, Kilifi, Kenya
2. Department of International Health, Johns Hopkins Bloomberg School of Public Health, Baltimore, Maryland, USA
3. Department of Infectious Disease Epidemiology, Faculty of Epidemiology and Population Health, London School of Hygiene and Tropical Medicine, London, United Kingdom
4. Kenya Ministry of Health, Nairobi, Kenya
5. Department of Public Health Solutions, National Institute for Health and Welfare (THL), Finland
6. Department of Mathematics and Statistics, University of Turku, Finland

Key words: pneumococcal conjugate vaccine; nasopharyngeal carriage; Kenya; mathematical model

Corresponding author:

John Ojal

PO Box 230- 80108

Kilifi, Kenya.

Tel +254 728 095 710

E-mail: jojal@kemri-wellcome.org / john.ojal@lshtm.ac.uk

Abstract

Background: In 2011, Kenya introduced the 10-valent pneumococcal conjugate vaccine together with a catch-up campaign for children aged <5 years in Kilifi County. In a post-vaccination surveillance study based in Kilifi, there was a substantial decline in invasive pneumococcal disease (IPD). However, given the continued circulation of the vaccine serotypes it is possible that vaccine-serotype disease may re-emerge once the effects of the catch-up campaign wear off.

Methods: We developed a compartmental, age-structured dynamic model of pneumococcal carriage and invasive disease for three serotype groups: the 10-valent vaccine serotypes and two groups of non-vaccine serotypes based on their susceptibility to mutual competition. The model was calibrated to age- and serotype-specific data on carriage and IPD in the pre-vaccination era and used to predict carriage prevalence and IPD up to ten years post-vaccination in Kilifi. The model was validated against the observed carriage prevalence after vaccine introduction.

Results: The model predicts a sustained reduction in vaccine-type pneumococcal carriage prevalence from 33% to 8% in infants and from 30% to 8% in 1-5 year olds over the 10-year period following vaccine introduction. The incidence of IPD is predicted to decline across all age groups resulting in an overall reduction of 56% in the population, corresponding to 10.4 cases per 100000 per year. The vaccine-type IPD incidence is estimated to decline by 83% while non-vaccine-type IPD incidence is predicted to increase by 52%. The model's predictions of carriage prevalence agree well with the observed data in the first five years post-vaccination.

Conclusion: We predict a sustained and substantial decline in IPD through PCV vaccination and that the current regimen is insufficient to fully eliminate vaccine-serotype circulation in the model. We show that the observed impact is likely to be sustained despite waning effects of the catch-up campaign.

Background

Reduction in nasopharyngeal carriage of vaccine-type pneumococci has been documented after vaccination with pneumococcal conjugate vaccines (PCVs) [1–3]. Moreover, by reducing pneumococcal acquisition, PCVs reduce pneumococcal transmission in the community offering indirect protection to the unvaccinated [4]. However, non-vaccine-type pneumococci rapidly colonise this vacated ecological niche, which can result in serotype replacement carriage [5] and replacement disease reducing the overall impact of PCVs [6]. With support from Gavi, The Vaccine Alliance, African countries have been introducing PCVs since 2009. Kenya introduced a 10-valent PCV (PCV10) targeting serotypes 1, 4, 5, 6B, 7F, 9V, 14, 18C, 19F and 23F in 2011. In Kilifi, a coastal area with enhanced surveillance for invasive pneumococcal disease (IPD) and carriage prevalence, the introduction was supplemented by a catch-up campaign in children <5 years old. At the same time annual carriage prevalence surveys have been conducted in the Kilifi Health and Demographic Surveillance System (KHDSS) population since 2009 [5].

Within a few months post-vaccination vaccine-type pneumococcal carriage and disease had dropped substantially in all age groups. However, vaccine serotypes (VTs) continue to circulate in the community [7,5]. This raises the concern that, after the population effects of the catch-up campaign have worn off, vaccine-type pneumococcal disease will re-emerge.

We developed a dynamic compartmental model parameterized with detailed data from the KHDSS population [8] to describe the pre-vaccination pneumococcal epidemiology and predict the long-term impact of PCV10 in Kilifi. We use post-vaccination data on carriage and disease over the past five years for validation of the model predictions.

Methods

Data

Kilifi County Hospital (KCH) is the main referral hospital in KHDSS. At KCH, morbidity events linked with the population register have been used to define the incidence of hospital presentation with infectious diseases, including IPD [8,9]. Datasets on pneumococcal carriage, IPD and contact patterns in KHDSS are described in detail elsewhere [5,10,11]. Here we briefly describe them as used in the current analysis.

Nasopharyngeal pneumococcal carriage surveys

Two cross-sectional surveys of pneumococcal carriage were done pre-vaccination. Nasopharyngeal swabs were collected and pneumococcal serotype-specific carriage ascertained [5] to obtain the pre-vaccination age-specific prevalence and serotype distribution of carriage. The two datasets were combined since there were no significant

differences between them in the carriage prevalence or serotype distribution (Appendix chapter 1).

The non-vaccine serotypes (NVTs) were classified as *weak* or *strong* based on their susceptibility to competition and carriage incidence, as estimated in a prior field study within KHDSS [12]. Strong NVTs (23B, 11A, 15A, 6A, 16F, 35B, 10A, 13, 23A 19A, 21; ordered by increasing susceptibility to competition) were less susceptible to competition. Two NVTs (34, 15B/C) were classified as strong for their higher carriage incidences compared to many of the ones chosen on the basis of susceptibility. The remaining NVTs were classified as weak (Appendix chapter 2).

Prospective diary survey

Selected residents from KHDSS filled in a diary on the ages of all persons they physically contacted on one randomly assigned weekday [10]. For children, the diary was completed by their guardians. This information defined a social mixing matrix of contact frequencies between age groups.

Carriage model structure

We developed a compartmental, age-structured dynamic model with 14 pneumococcal carriage states (Figure 1). The model has a Susceptible-Infected-Susceptible (SIS) structure for three serotype groups: the PCV10 serotypes, strong NVT and weak NVT.

At any point in time, an unvaccinated individual can be susceptible (non-carrying) in state S ; carry a VT, V ; carry a weak NVT, N_w ; carry a strong NVT, N_s ; carry simultaneously a

weak and strong NVT, N_{sw} ; carry simultaneously a VT and weak NVT, B_w ; or carry simultaneously a VT and a strong NVT, B_s . Once vaccinated, the individual moves to one of the corresponding states ($S^{(v)}$, $V^{(v)}$, $N_w^{(v)}$, $N_s^{(v)}$, $N_{sw}^{(v)}$, $B_w^{(v)}$, $B_s^{(v)}$). The equations of inter-state transitions are presented in Appendix chapter 3.

Parameterisation

Population structure

The model population is stratified into six age groups (<1, 1-5, 6-14, 15-20, 21-49 and \geq 50 years) corresponding to those in the diary survey and reflecting the age structure in KHDSS as of 1st January 2010. Individuals in the model are born completely susceptible to carriage according to prevailing birth rates and die according to age-specific mortality rates from KHDSS (Table 1).

Acquisition of carriage

A susceptible unvaccinated individual in age group i becomes colonised with VTs, strong NVTs or weak NVTs at age-group-specific time-dependent rates (forces of infection) denoted by $\lambda_{Vi}(t)$, $\lambda_{Nsi}(t)$ and $\lambda_{Nwi}(t)$, respectively. The forces of infection were expressed as functions of the social mixing matrix and age-group specific factors (q_i) that scale the rate of social contacts into infectious contacts (Appendix chapter 3). Due to competition between serotypes in colonising the nasopharynx, the acquisition rate of a secondary serotype is lower than the acquisition rate of that serotype in a completely susceptible individual. Three competition parameters, c_{v0} , c_{w0} and c_{s0} , represent the fraction by which acquisition rates of secondary serotypes are reduced in <6 year olds infected with VTs,

weak NVTs and strong NVTs, respectively. Two competition parameters, $c_{vw} = c_v = c_w$ and c_s , were used for individuals aged ≥ 6 years infected with VTs/weak NVTs and strong NVTs, respectively.

Clearance of carriage

The immune clearance rates of carriage (Appendix chapter 4) depend on the serotype group and age (<1, 1-5 and >5 years) and were obtained from a prior study in Kenyan children [12].

Disease

For each serotype group and age group, case-to-carrier ratios were calculated as ratios of the observed IPD incidence at KCH [11] to the respective model-predicted pre-vaccination carriage incidence. The case-to-carrier ratios were assumed to remain unchanged post-vaccination and were multiplied with the predicted carriage incidence to predict post-vaccination IPD incidence.

Vaccination

In Kenya, children receive PCV10 at age 6, 10 and 14 weeks. In the model, $\eta=80\%$ of all newborns are considered vaccinated at age 18 weeks, one month after the third dose of the 3-dose series (Table 1). A catch-up programme is simulated by vaccinating 65% of children younger than 5 years at the onset of the vaccination programme. Upon vaccination, an individual moves to the corresponding state in the vaccine-protected compartment based on his/her prevailing carriage status.

The vaccine efficacy against carriage is modelled as a 50% reduction ($\varepsilon = 0.50$) in the acquisition rate of VTs in a vaccinated individual relative to an unvaccinated individual (Table 1). The vaccine efficacy against carriage progression to disease (VE_{prog}) was calculated as a function of ε and the vaccine efficacy against IPD ($VE_{IPD} = 85\%$) as:

$$VE_{prog} = 1 - \frac{1 - VE_{IPD}}{1 - \varepsilon} = 70\%.$$

We assumed that a proportion $\varphi = 0.12$ of the vaccinated population loses their protection every year. This corresponds to an average duration of protection for an individual of just over 8 years (Table 1).

Implementation and model calibration

In the first stage, the stationary solution of the transmission model was fitted to the age-stratified pre-vaccination carriage prevalence and serotype distribution (Appendix chapter 1). Using a multinomial likelihood function and uninformative priors in a Bayesian framework, the five competition parameters (c_{vw} , c_{v0} , c_s , c_{s0} and c_{w0}) and six scaling/infectivity parameters ($q_1, q_2, q_3, q_4, q_5, q_6$) were estimated (Appendix chapter 5). In each iteration, bootstrapping the social contact data and reconstructing the mixing matrix incorporated uncertainty in the social contact rates. A stationary population with equal birth and mortality rates was assumed.

In the second stage, the posterior samples of model parameters obtained in the first stage were applied in a prediction model. Projections were made assuming a constant population. To measure how fast the effect of the catch-up campaign wanes, we calculated the additional cases of IPD the campaign prevents in the first 10 years and

estimated the time required to achieve 90% of that effect. Simulations were performed in R [13].

Sensitivity analysis

The sensitivity of the predicted IPD incidence averted, i.e., the difference in the overall incidence of IPD before and at 10 years post-vaccination, was assessed with respect to uncertainties in the assumed levels of: (i) vaccine efficacy against carriage acquisition; (ii) vaccine efficacy against IPD; (iii) the waning rate of vaccine-induced protection against carriage; (iv) vaccine coverage.

We performed additional simulations under a growing population using birth and death rates corresponding to the local demographics [8]. The probabilities of contact per person per day were recalculated for each time step according to the current population (Appendix chapter 6).

Model validation

We visually assessed proximity of the base-case predictions of the age-group specific carriage of VTs and NVTs to the corresponding observed values over a five-year period post-vaccination (2011-2015).

Results

Model fit to pre-vaccination epidemiology

There was a good agreement between the observed age-group and serotype-group specific pre-vaccination carriage prevalence and their posterior estimates (Figure 2). Within each age group, the 95% credible intervals agreed with the data. Nonetheless, the differences in the posterior mean estimates of the proportions of carriers of VTs and NVTs among pneumococcal carriers were in most instances larger than observed in individuals ≥ 6 years old, compared to the differences in individuals < 6 years old.

Competition parameters

The probability of infection per contact was higher among 1-5 and 6-14 year olds as compared to other age groups (Table 1). An individual < 6 years carrying a vaccine-serotype had a 61% (95% credible interval, CrI, 29%-85%) protection against acquiring NVTs, relative to an uninfected individual of the same age group. In older age groups, the corresponding level of protection was 23% (95% CrI 1%-70%).

Model projections on pneumococcal carriage

Under the base-case model, the overall prevalence of pneumococcal carriage was estimated to remain essentially at its pre-vaccination level, with only a slight reduction from 44% to 41% within 10 years post-vaccination. The prevalence of VTs in the overall population was estimated to reduce from 16% to 4%, with a simultaneous increase in the prevalence of NVTs from 28% to 36%.

The prevalence of VTs was predicted to reduce in all age groups. In the older, mostly unvaccinated population, the reduction was estimated to be about two thirds of the pre-vaccination level (Table 2), suggesting a benefit of herd immunity. Changes in the

prevalence of VTs and NVTs occur within the first 4 to 5 years post-vaccination and little change was predicted thereafter (Figure 3).

Model projections on IPD

The incidence of IPD from VTs was projected to decline in all age groups. The changes in IPD and carriage were linked and over 50% reduction in IPD occurs within the first 4 to 5 years after PCV introduction. The overall reduction in the incidence of IPD ten years post-vaccination is predicted to be 56% (Table 3). The overall reduction in the incidence of IPD from year 5 to 10 was 7% (95% predictive interval: -0.4% to 14%). As a result of waning direct effects of the catch-up campaign and increasing herd-effects of routine immunisation with time, we estimated that the incremental benefit of a catch-up over routine vaccination alone would be negligible from year 7 after introduction of PCV10.

Sensitivity analyses

Among the variables included in the sensitivity analysis, the duration of protection had the largest effect on the predicted IPD incidence averted in year 10, followed by the vaccine efficacy against carriage. The vaccine efficacy against IPD had the least influence (Figure S1).

Assuming a growing population, the overall prevalence of carriage was projected to decline to a somewhat lower level of 35% (95% prediction interval 30%-40%) ten years post-vaccination (Appendix chapter 7).

Model validation

The point predictions and corresponding 95% prediction intervals (PI) of carriage prevalence cover most of the observed values, showing good predictive ability (Figure S2). Among <1 and 1-5 year olds the model predicted much lower carriage prevalence of NVTs in year 2015 (49% vs. 70% observed and 38% vs. 52% observed, respectively).

Discussion

We used a model calibrated with local data to predict the incidence of pneumococcal carriage and IPD in Kilifi, Kenya, over a 10-year period post-vaccination to assess whether additional measures have to be considered to prevent a resurgence of vaccine-type pneumococci once the impact of the catch-up campaign wanes. We validated the model against immediate post-vaccination epidemiological data, a unique exercise in pneumococcal carriage models, and found that such resurgence is unlikely if the routine immunisation programme continues.

Most PCV introductions in African countries have occurred since year 2011. Therefore, only a few years of observation are available to assess impact. A meta-analysis of four randomized trials in African children aged 9–24 months showed that carriage of VTs decreased with vaccination but the overall carriage remained the same [14]. In the United Kingdom, the overall prevalence of pneumococcal carriage was stable four years post-vaccination [15]. In our model predictions, the overall carriage prevalence remains essentially unchanged due to serotype replacement in carriage. Replacement carriage was most prominent in <6 year olds because the pre-vaccination proportion of VTs among pneumococcal carriers was highest in young children (Appendix chapter 1). We predict that elimination of VTs in this community is unlikely. In high-income countries that have almost eliminated circulation of VTs, a reduced-dose schedule has been considered to

improve the cost-effectiveness of the program [16]. The World Health Organization (WHO) also recently convened a working group to review the policy recommendations for the optimal use of PCVs in low- and middle-income countries, which includes discussion of reduced dose schedules [17]. Theoretically, where herd protection has been established, it may be possible to sustain it using, for example, a single dose in infancy and a booster dose in the second year of life. In the Kenyan setting, however, where vaccine-type pneumococci continue to circulate several years post introduction of PCV with a catch-up campaign, it would be difficult to argue that disease prevention among infants is currently guaranteed by herd protection.

In the model presented, the incidence of IPD is predicted to decline across all age groups. The non-vaccine-type IPD incidence is expected to increase by 52%, which translates to an increase in the annual incidence of 1.9 per 100000, suggesting little replacement disease relative to the reduction in the annual overall vaccine-type IPD incidence of 12.3 per 100000. This is explained by the lower average case-to-carrier ratios (i.e., lower invasiveness) of the replacing non-vaccine serotypes (Appendix chapter 8).

South Africa and The Gambia introduced PCV7 in 2009 and replaced it with PCV13 in 2011 [18,19]. The reduction in vaccine-type and overall IPD reported in these countries are similar to the predictions our model produces for Kilifi, Kenya, over the first few years post-vaccination. This, however, does not validate the model because of differences across the settings. The vaccination coverage in Kenya is likely to differ from coverage in The Gambia and South Africa, and Kenya introduced PCV10. We thus validated our model predictions against observed carriage prevalence and IPD incidence in Kilifi. The model predictions were generally consistent with the observed data (Figure S2). The model, however, underestimated prevalence of carriage of NVTs in <6 year olds in 2014-15.

Relaxing the assumption of a constant population size only made minimal difference to the goodness of fit (Figure S3).

Pneumococcal serotypes are heterogeneous in transmissibility and mutual competition [12,20]. By splitting the NVTs into two groups and allowing unequal mutual competition between these groups, our model accounts for some of this heterogeneity. We did not split VTs because we aimed to reproduce serotype replacement with as small a number of parameters as possible, by limiting the number of compartments. Splitting NVTs was preferred because the group has a larger number of serotypes and hence more heterogeneity. The model projected differing magnitudes of change in the prevalence of the strong and weak NVTs. Given the different case-to-carrier ratios of the two groups of NVTs (Appendix chapter 8), the projected non-vaccine-type IPD incidence is different from what would have been predicted using a single group of NVTs. Nonetheless, grouping serotypes can create some 'super types' that might have different characteristics, e.g. higher acquisition rate of the VTs group compared to the individual serotypes in the group. This might lead to conservative vaccine effectiveness estimates. Grouping of serotypes may also result in the estimated acquisition rate of NVTs being lower than that of individual serotypes in the group. This would lead to an underestimation of the indirect impact of vaccination on NVTs - lower than the observed predicted prevalence of NVTs.

To limit the number of estimated parameters, age dependency in competition was considered using two age classes (<6 and ≥ 6 years). Some discrepancies between the fitted and observed age-specific serotype distributions were present. The proportion of carriers of VTs was overestimated among carriers aged ≥ 15 years (Figure 2); the susceptibility to competition of VTs against NVTs is likely biased downwards in adults, thus underestimating the reduction in prevalence of VTs. With our current specification, the

estimates of competition parameters in age group ≥ 6 years largely depend on data from the age groups 6-14 years. A model including more groups of VTs and NVTs or individual serotypes [21–23] would allow for even more heterogeneity. However, the estimation of competition parameters from available carriage data would become increasingly difficult in a highly compartmentalized model.

We estimated case-to-carrier ratios using hospital-based data on IPD incidence in KHDSS [8]. The access to care for IPD is unknown in KHDSS, but meningitis incidence is underestimated by over 30% by hospital-based surveillance [24]. Since IPD and meningitis are severe syndromes, the underestimation of IPD incidence could be similar implying case-to-carrier ratios are likely underestimated. Nonetheless, since the ratios estimated pre-vaccination are applied post-vaccination, the predicted reduction in IPD is not affected.

We excluded partial protection from first and second doses. Our estimates of the vaccine impact may thus be conservative if the vaccines' efficacy is substantial after fewer than three doses. We treated vaccine efficacy against carriage and its waning as equal for routine and catch-up vaccination. A Kenyan trial estimated vaccine efficacy against carriage of 40% among children aged 1-4 years [3], lower than the 50% for infant vaccination [25–27]. The duration of protection of catch-up vaccination is not documented yet. One dose of PCV administered outside of infancy may have a more enduring effect than 3 routine infant doses. If so, our similar treatment of the duration of immunity means there is no inflection on the carriage prevalence of VTs as the cohort of highly immune <5 year olds who received a catch-up dose is replaced by a new birth cohort of less immune children over time.

We assumed children are born completely susceptible to acquisition of pneumococcus ignoring the influence of maternal antibodies. Newborns in a Kenyan study had a very high rate of first acquisition [20]. Early acquisition has also been reported in other African settings [28–30]. In Netherlands and Papua New Guinea a protective effect of maternal IgG antibodies against colonisation in infancy was not observed [31,32]. Based on high early acquisition rates and insufficient evidence of protection from maternal antibodies in some studies, this assumption is plausible.

A significant reduction in IPD caused by vaccine-related serotypes 6A and 19A IPD has been observed in some PCV10-using settings [33]. However, surveillance in Kilifi recorded no change in carriage of serotype 6A and increased carriage of serotype 19A after vaccine introduction [7]. We have not observed a change in IPD caused by these serotypes. We therefore did not account for 6A and 19A as vaccine serotypes.

In conclusion, we predict a substantial and sustainable decline in the carriage prevalence of VTs among vaccinated and unvaccinated individuals and consequently a reduction of about 56% in overall IPD incidence ten years post-vaccination. While we show that the current schedule is sufficient to limit vaccine-type pneumococcal carriage to current levels, it is unlikely to achieve elimination of VTs. Strategies that heavily rely on protection from the herd, including a reduced dose schedule, will need additional efforts to stop circulation of VTs before their implementation.

Author Contributions

Conceived the study: JO, KA, MN, JAGS, SF. Model coding and simulations: JO.

Conducted the pneumococcal carriage surveys and/or facilitated IPD surveillance in Kilifi:

LLH, DA, IA, JAGS, TK. Conducted the social contact survey: MCK. All authors: read and appraised the scientific content of the manuscript.

Ethics statement

The study was part of the Pneumococcal Conjugate Vaccine Impact Study (PCVIS) approved by the Kenya Medical Research Institute (KEMRI) Ethical review committee (SCC 1433). It has an additional approval by OXTREC (OXTREX 30-10), the Oxford Tropical Research Ethics Committee, with delegated authority from the London School of Hygiene & Tropical Medicine (LSHTM) Research Ethics Committee.

Acknowledgements

This paper is published with the permission of the Director, KEMRI. The work was funded by the Wellcome Trust through fellowship support to John Ojal (092767) and Prof. Anthony Scott (098532). The social contact study was funded by Wellcome Trust fellowship to Prof. James Nokes (084633) and Moses C. Kiti (098556). We acknowledge Dr. Shahnaaz K. Sharif of the Kenya Ministry of health for his involvement in the design and conduct of the pneumococcal carriage surveys in Kilifi.

Conflict of interest: None.

References

- [1] Dagan R, Givon-Lavi N, Zamir O, Sikuler-Cohen M, Guy L, Janco J, et al. Reduction of nasopharyngeal carriage of *Streptococcus pneumoniae* after administration of a 9-valent pneumococcal conjugate vaccine to toddlers attending day care centers. *J Infect Dis* 2002;185:927–36.
- [2] Dagan R, Muallem M, Melamed R, Leroy O, Yagupsky P. Reduction of pneumococcal nasopharyngeal carriage in early infancy after immunization with tetravalent pneumococcal vaccines conjugated to either tetanus toxoid or diphtheria toxoid. *Pediatr Infect Dis* 1997;16:1060–4.
- [3] Hammitt LL, Ojal J, Bashraheil M, Morpeth SC, Karani A, Habib A, et al. Immunogenicity, Impact on Carriage and Reactogenicity of 10-Valent Pneumococcal Non-Typeable *Haemophilus influenzae* Protein D Conjugate Vaccine in Kenyan Children Aged 1-4 Years: A Randomized Controlled Trial. *PLoS One* 2014;9:e85459. doi:10.1371/journal.pone.0085459.
- [4] Davis SM, Deloria-Knoll M, Kassa HT, O'Brien KL. Impact of pneumococcal conjugate vaccines on nasopharyngeal carriage and invasive disease among unvaccinated people: Review of evidence on indirect effects. *Vaccine* 2013;32:133–45. doi:10.1016/j.vaccine.2013.05.005.
- [5] Hammitt LL, Akech DO, Morpeth SC, Karani A, Kihuha N, Nyongesa S, et al. Population effect of 10-valent pneumococcal conjugate vaccine on nasopharyngeal carriage of *Streptococcus pneumoniae* and non-typeable *Haemophilus influenzae* in Kilifi, Kenya: findings from cross-sectional carriage studies. *Lancet Glob Heal* 2014;8–10. doi:10.1016/S2214-109X(14)70224-4.
- [6] Weinberger DM, Malley R, Lipsitch M. Serotype replacement in disease after pneumococcal vaccination. *Lancet* 2011;378:1962–73. doi:10.1016/S0140-6736(10)62225-8.
- [7] Hammitt LL, Akech DO, Morpeth SC, Karani A, Nyongesa S, Ooko M, et al. Population impact of 10-valent pneumococcal conjugate vaccine (PCV) on nasopharyngeal carriage of *Streptococcus pneumoniae* in Kilifi, Kenya. 10th Int. Symp. Pneumococci Pneumococcal Dis., Glasgow, Scotland.: 2016.
- [8] Scott JAG, Bauni E, Moisi JC, Ojal J, Gatakaa H, Nyundo C, et al. Profile: The Kilifi Health and Demographic Surveillance System (KHDSS). *Int J Epidemiol* 2012;41:650–7. doi:10.1093/ije/dys062.
- [9] Adetifa IMO, Bwanaali T, Wafula J, Mutuku A, Karia B, Makumi A, et al. Cohort Profile: The Kilifi Vaccine Monitoring Study. *Int J Epidemiol* 2016:dyw202. doi:10.1093/ije/dyw202.
- [10] Kiti MC, Kinyanjui TM, Koech DC, Munywoki PK, Medley GF, Nokes DJ. Quantifying age-related rates of social contact using diaries in a rural coastal population of Kenya. *PLoS One* 2014;9:e104786. doi:10.1371/journal.pone.0104786.
- [11] Scott Anthony, Hammit Laura, Karia Boniface, Mutuku Alex, Shariff Shannaaz, Kamau Tatu, et al. Pneumococcal Conjugate Vaccine Impact Study (PCVIS) n.d. <http://kemri-wellcome.org/programme/pcvis-2/> (accessed January 13, 2017).
- [12] Lipsitch M, Abdullahi O, D'amour A, Xie W, Weinberger DM, Tchetgen ET, et al.

Estimating Rates of Carriage Acquisition and Clearance and Competitive Ability for Pneumococcal Serotypes in Kenya With a Markov Transition Mode. *Epidemiology* 2012;23:1–10. doi:10.1097/EDE.0b013e31824f2f32.

- [13] R Core Team. R: A Language and Environment for Statistical Computing 2014. doi:<https://www.r-project.org/>.
- [14] Usuf E, Bottomley C, Adegbola R a, Hall A. Pneumococcal carriage in sub-Saharan Africa--a systematic review. *PLoS One* 2014;9:e85001. doi:10.1371/journal.pone.0085001.
- [15] Gladstone RA, Jefferies JM, Tocheva AS, Beard KR, Garley D, Wei W, et al. Five winters of pneumococcal serotype replacement in UK carriage following PCV introduction. *Vaccine* 2015;33:2015–21.
- [16] Flasche S, Van Hoek AJ, Goldblatt D, Edmunds WJ, O'Brien KL, Scott JAG, et al. The Potential for Reducing the Number of Pneumococcal Conjugate Vaccine Doses While Sustaining Herd Immunity in High-Income Countries. *PLoS Med* 2015;12:1–5. doi:10.1371/journal.pmed.1001839.
- [17] Call for nomination for experts to serve on a Strategic Advisory Group of Experts (SAGE) on Immunization working group on Pneumococcal Conjugate Vaccine (PCV). WHO Website 2016. http://www.who.int/immunization/policy/sage/call_nominations_working_group_pcv/en/ (accessed December 21, 2016).
- [18] Mackenzie GA, Hill PC, Jeffries DJ, Hossain I, Uchendu U, Ameh D, et al. Effect of the introduction of pneumococcal conjugate vaccination on invasive pneumococcal disease in The Gambia: A population-based surveillance study. *Lancet Infect Dis* 2016;703–11. doi:10.1016/S1473-3099(16)00054-2.
- [19] von Gottberg A, de Gouveia L, Tempia S, Quan V, Meiring S, von Mollendorf C, et al. Effects of Vaccination on Invasive Pneumococcal Disease in South Africa. *N Engl J Med* 2014;371:1411–14. doi:10.1056/NEJMoa1401914.
- [20] Tigoï CC, Gatakaa H, Karani A, Mugo D, Kungu S, Wanjiru E, et al. Rates of acquisition of pneumococcal colonization and transmission probabilities, by serotype, among newborn infants in Kilifi District, Kenya. *Clin Infect Dis* 2012;55:180–8. doi:10.1093/cid/cis371.
- [21] Cobey S, Lipsitch M. Niche and neutral effects of acquired immunity permit coexistence of pneumococcal serotypes. *Science* 2012;335:1376–80. doi:10.1126/science.1215947.
- [22] Flasche S, Edmunds WJ, Miller E, Goldblatt D, Robertson C, Choi YH. The impact of specific and non-specific immunity on the ecology of *Streptococcus pneumoniae* and the implications for vaccination. *Proc Biol Sci* 2013;280:20131939. doi:10.1098/rspb.2013.1939.
- [23] Bottomley C, Roca A, Hill PC, Greenwood B, Isham V. A mathematical model of serotype replacement in pneumococcal carriage following vaccination. *J R Soc Interface* 2013;10.
- [24] Moïsi JC, Nokes DJ, Gatakaa H, Williams TN, Bauni E, Levine OS, et al. Sensitivity of hospital-based surveillance for severe disease: a geographic information system analysis of access to care in Kilifi district, Kenya. *Bull World Health Organ* 2011;89:102–11. doi:10.2471/BLT.10.080796.
- [25] O'Brien K, Moulton L, Reid R, Weatherholtz R, Oski J, Brown L, et al. Efficacy,

safety and immunogenicity of heptavalent pneumococcal conjugate vaccine in children. Northern California Kaiser Permanente Vaccine Study Center Group. *Pediatr Infect Dis J* 2000;19:187–95.

- [26] O'Brien K, Moulton L, Reid R, Weatherholtz R, Oski J, Brown L, et al. Efficacy and safety of seven-valent conjugate pneumococcal vaccine in American Indian children: group randomised trial. *Lancet* 2003;362:355–61.
- [27] Cutts FT, Zaman SMA, Enwere G, Jaffar S, Levine OS, Okoko JB, et al. Efficacy of nine-valent pneumococcal conjugate vaccine against pneumonia and invasive pneumococcal disease in The Gambia: randomised, double-blind, placebo-controlled trial. *Lancet* 2005;365:1139–46. doi:10.1016/S0140-6736(05)71876-6.
- [28] Gratten M, Gratten H, Poli A, Carrad E, Raymer M, Koki G. Colonisation of *Haemophilus influenzae* and *Streptococcus pneumoniae* in the upper respiratory tract of neonates in Papua New Guinea: primary acquisition, duration of carriage, and relationship to carriage in mothers. *Biol Neonate* 1986;50:114–20.
- [29] Hill PC, Cheung YB, Akisanya A, Sankareh K, Lahai G, Greenwood BM, et al. Nasopharyngeal carriage of *Streptococcus pneumoniae* in Gambian infants: a longitudinal study. *Clin Infect Dis* 2008;46:807–14. doi:10.1086/528688.
- [30] Montgomery J, Lehmann D, Smith T, Michael A, Joseph B, Lupiwa T, et al. Bacterial colonization of the upper respiratory tract and its association with acute lower respiratory tract infections in Highland children of Papua New Guinea. *Rev Infect Dis* 1990;Suppl 8:S1006-16.
- [31] Lebon A, Verkaik NJ, Labout J a M, de Vogel CP, Hooijkaas H, Verbrugh H a., et al. Natural antibodies against several pneumococcal virulence proteins in children during the pre-pneumococcal-vaccine era: The generation R study. *Infect Immun* 2011;79:1680–7. doi:10.1128/IAI.01379-10.
- [32] Francis JP, Richmond PC, Pomat WS, Michael A, Keno H, Phuanukoonnon S, et al. Maternal antibodies to pneumolysin but not to pneumococcal surface protein a delay early pneumococcal carriage in high-risk Papua New Guinean infants. *Clin Vaccine Immunol* 2009;16:1633–8. doi:10.1128/CVI.00247-09.
- [33] Jokinen J, Rinta-Kokko H, Siira L, Palmu AA, Virtanen MJ, Nohynek H, et al. Impact of ten-valent pneumococcal conjugate vaccination on invasive pneumococcal disease in Finnish children - A population-based study. *PLoS One* 2015;10:1–11. doi:10.1371/journal.pone.0120290.
- [34] Lucero MG, Dulalia VE, Nillos LT, Williams G, Parreño RAN, Nohynek H, et al. Pneumococcal conjugate vaccines for preventing vaccine-type invasive pneumococcal disease and X-ray defined pneumonia in children less than two years of age (Review). *Cochrane Database Sytematic Rev* 2009 2010;CD004977.
- [35] Choi YH, Jit M, Gay N, Andrews N, Waight P a, Melegaro A, et al. 7-Valent pneumococcal conjugate vaccination in England and Wales: is it still beneficial despite high levels of serotype replacement? *PLoS One* 2011;6:e26190. doi:10.1371/journal.pone.0026190.

Table 1: Parameters of the dynamic transmission model and the sources of information. The parameters are classified as those estimated (calibrated) in the context of the model and those derived from external sources.

Parameter / input	Estimate/Value (Interval)*	Source
Calibrated		
Competition parameters	$c_{s0} = 0.44$ (0.13, 0.82) $c_{w0} = 0.59$ (0.19, 0.96) $c_{v0} = 0.39$ (0.15, 0.71) $c_s = 0.11$ (0.004, 0.49) $c_{vw} = c_v = c_w = 0.77$ (0.30, 0.99)	Estimated
Probability of infection per 100 contacts	$q_1 = 0.13$ (0.07, 0.25) $q_2 = 0.40$ (0.30, 0.55) $q_3 = 0.32$ (0.24, 0.43) $q_4 = 0.07$ (0.04, 0.13) $q_5 = 0.16$ (0.11, 0.23) $q_6 = 0.06$ (0.04, 0.09)	Estimated
Case-to-carrier ratios**	Appendix chapter 7	[11]
From external sources		
Clearance rates	Appendix chapter 3	[12]
Birth rate	32.0 per 1000/year	[8]
Age-specific mortality	Appendix chapter 5	[8]
Contact rates		[10]
Vaccine efficacy against carriage acquisition (ε)	50% (40-60)	[3,25–27]
Vaccine efficacy against IPD	85% (80-90)	[34]
Waning rate of protection against carriage (φ)	0.12 per year (0.09 – 0.20)	[35]
Routine vaccination coverage (η)	80% (70-90)	[9,11]
Catch-up coverage	65% (60-70)	[9,11]

* The intervals indicated for the estimated parameters are 95% credible intervals. The intervals indicated for the rest of the parameters are the ranges within which they were sampled in the model to account for their uncertainty and assess the model's sensitivity.

**IPD incidence from Kilifi district hospital in KHDSS is divided by the carriage incidence from the model to obtain case-to-carrier ratios (Appendix chapter 7)

Table 2: The prevalence of nasopharyngeal carriage of pneumococci pre- and 10 years post-vaccination. The table presents the posterior predictive mean values with the 95% posterior predictive intervals.

Age group (years)	Pre-vaccination				10 years post-vaccination			
	Carriage prevalence	VT*	Strong NVT**	Weak NVT	Carriage prevalence	VT	Strong NVT	Weak NVT
<1	80.8 (67.8-90.1)	32.6 (25.1-40.5)	37.5 (30.6-45.8)	9.9 (7.1-13.2)	75.7 (61.4-87.2)	8.3 (1.6-18.2)	50.9 (40.9-62.6)	15.2 (10.5-22.2)
1-5	72.5 (65.2-78.5)	29.5 (23.9-35.2)	29.7 (24.6-35.2)	13.1 (9.6-17.0)	67.2 (58.9-74.6)	8.0 (1.5-16.9)	39.2 (32.2-48.5)	19.3 (14.1-25.5)
6-14	54.0 (43.1-64.8)	17.0 (13.9-21.2)	26.8 (18.9-35.0)	9.9 (7.4-13.5)	49.7 (38.6-61.0)	4.4 (0.9-9.6)	32.0 (23.6-41.2)	12.8 (9.5-17.1)
15-20	27.9 (17.0-41.7)	9.1 (5.7-13.9)	13.4 (7.6-20.7)	5.3 (3.1-8.6)	25.3 (15.6-38.0)	2.5 (0.5-6.0)	15.8 (9.5-24.3)	6.8 (4.1-10.8)
21-49	25.5 (17.0-35.5)	8.6 (5.8-12.1)	12.0 (7.6-17.5)	4.8 (3.0-7.2)	23.2 (15.2-33.0)	2.5 (0.5-5.6)	14.2 (9.2-20.9)	6.2 (3.9-9.3)
50+	21.0 (14.0-30.0)	7.1 (4.7-10.1)	9.8 (6.2-14.6)	4.0 (2.6-6.0)	19.1 (12.7-27.3)	2.0 (0.4-4.5)	11.7 (7.6-17.2)	5.2 (3.3-7.9)
Overall	44.4 (40.2-48.9)	15.9 (13.3-18.7)	20.4 (16.8-24.2)	8.0 (6.1-10.2)	40.8 (36.0-46.0)	4.3 (0.8-9.1)	25.4 (21.2-30.0)	10.9 (8.4-13.8)

* Vaccine serotypes

** Non-vaccine serotypes

Table 3: The incidence of invasive pneumococcal disease (IPD) pre- and 10 years post-vaccination. The table presents the posterior predictive mean values with the 95% predictive intervals.

Age group (years)	Pre-vaccination IPD incidence (/100,000/year)			10 years post-vaccination IPD incidence (/100,000/year)			IRR*
	VT	Strong NVT	Weak NVT	VT	Strong NVT	Weak NVT	
<1	67.0	21.0	7.1	6.7 (1.1, 15.1)	37.0 (29.5, 50.4)	11.6 (9.4, 15.6)	0.59 (0.51, 0.72)
1-5	39.3	5.1	0.7	6.4 (1.2, 14.7)	7.8 (6.5, 10.0)	1.1 (0.9, 1.4)	0.34 (0.24, 0.50)
6-14	7.3	1.0	0.0	1.4 (0.3, 3.3)	1.2 (1.1, 1.5)	0.0 (0.0, 0.0)	0.33 (0.20, 0.54)
15-20	1.0	0.0	0.0	0.3 (0.1, 0.5)	0.0 (0.0, 0.0)	0.0 (0.0, 0.0)	0.26 (0.05, 0.54)
21-49	4.2	0.9	0.0	1.2 (0.2, 2.3)	1.1 (1.0, 1.3)	0.0 (0.0, 0.0)	0.45 (0.28, 0.66)
≥50	9.2	2.8	4.1	2.5 (0.5, 5.1)	3.4 (3.1, 3.9)	5.3 (4.7, 6.3)	0.71 (0.60, 0.82)
All ages	14.8	2.7	0.9	2.5 (0.5, 5.6)	4.2 (3.5, 5.3)	1.3 (1.1, 1.6)	0.44 (0.34, 0.56)

(*) The incidence rate ratio (IRR) is between the overall IPD incidence before vaccination and the IPD incidence 10 years post vaccination.

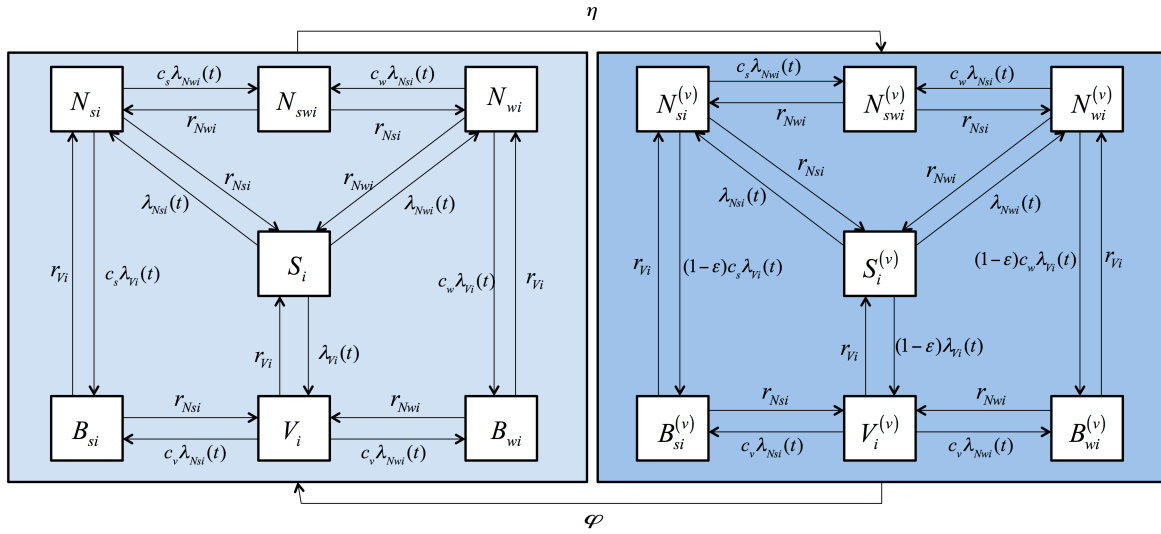

Figure 1. Model structure flow diagram. The epidemiological states include individuals that are susceptible (non-carrying), S ; carry a vaccine serotype, V ; carry a weak non-vaccine serotype, N_w ; carry a strong non-vaccine serotype, N_s ; carry simultaneously a weak and a strong non-vaccine serotype, N_{sw} ; carry simultaneously a vaccine serotype and a weak non-vaccine serotype, B_w ; or carry simultaneously a vaccine serotype and a strong non-vaccine serotype, B_s (see text). Once vaccinated, the individual moves to one of the corresponding states, $(S^{(v)}, V^{(v)}, N_w^{(v)}, N_s^{(v)}, B_w^{(v)}$ and $B_s^{(v)})$. The acquisition rates from the single to multiple serotype carriage states are reduced by competition parameters denoted by c with two subscripts; the first denoting the serotype group (v, s and w , for VT, strong NVT and weak NVT respectively) of the resident serotypes and the second denoting the age-group. The competition parameters have two sets of values, one for age group <6 and another for age group ≥ 6 years (see text). The age-group specific VT, weak NVT and strong NVT clearance rates are denoted by r_{Vi} , r_{Nwi} and r_{Nsi} , respectively. In addition to the transitions between the 14 epidemiological states as shown in the Figure, individuals die from any states at age-specific death rates and new individuals are born into the completely susceptible state.

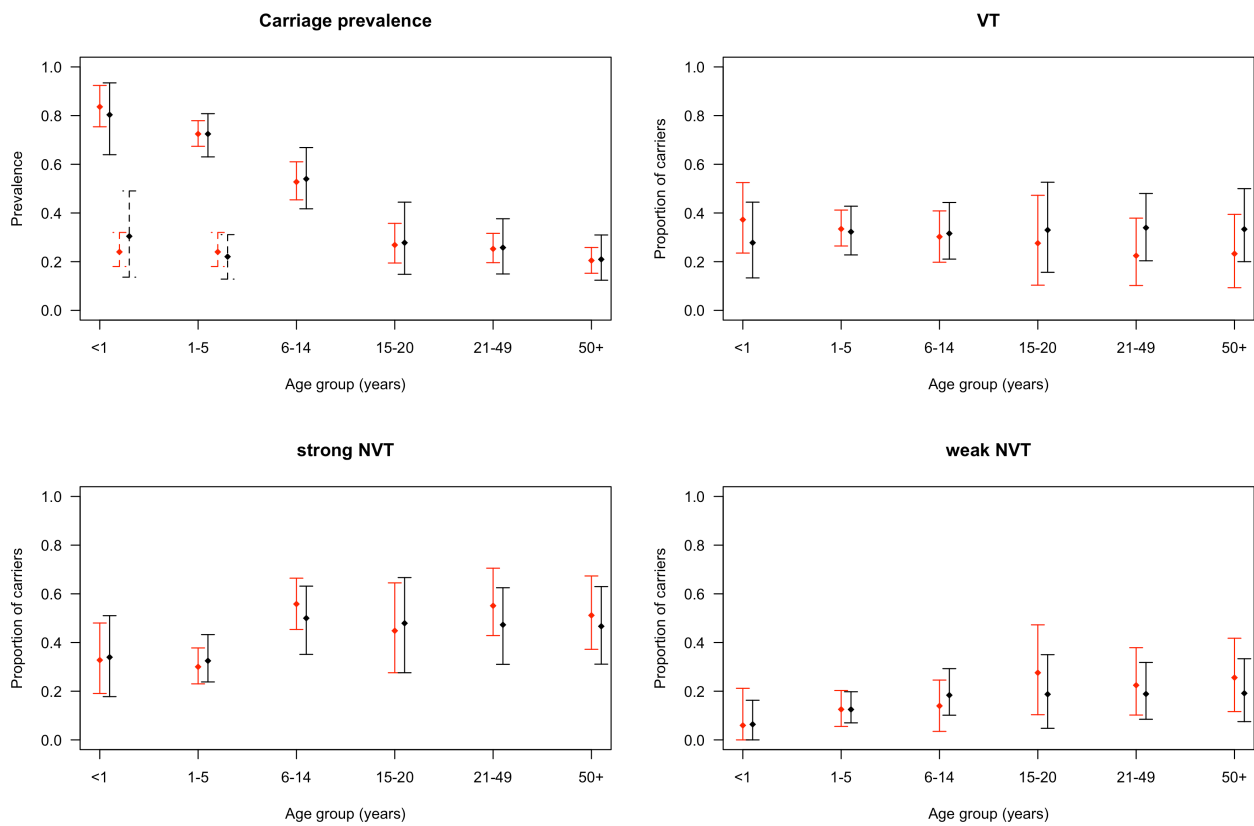

Figure 2. Model fit. Observed prevalence (red points) of pneumococcal carriage across age groups (top-left panel) and the proportion of carriers of VT (top-right panel), strong NVT (bottom-left panel) and weak NVT (bottom-right panel) among pneumococcal carriers prior to vaccine introduction. The black points show the corresponding estimated values of the prevalence/proportion, based on data given in Appendix chapter 1. The capped bars represent the 95% credible intervals. The dotted lines in the top-left panel (and the points they pass through) are the observed (red) and the predicted (black) proportions of double carriers among <1 and 1-5 year olds. For these two age groups, the top-right, bottom-left and bottom-right panels present the proportions of single carriers of the respective types (VT, strong NVT, weak NVT) among all carriers in the age group.

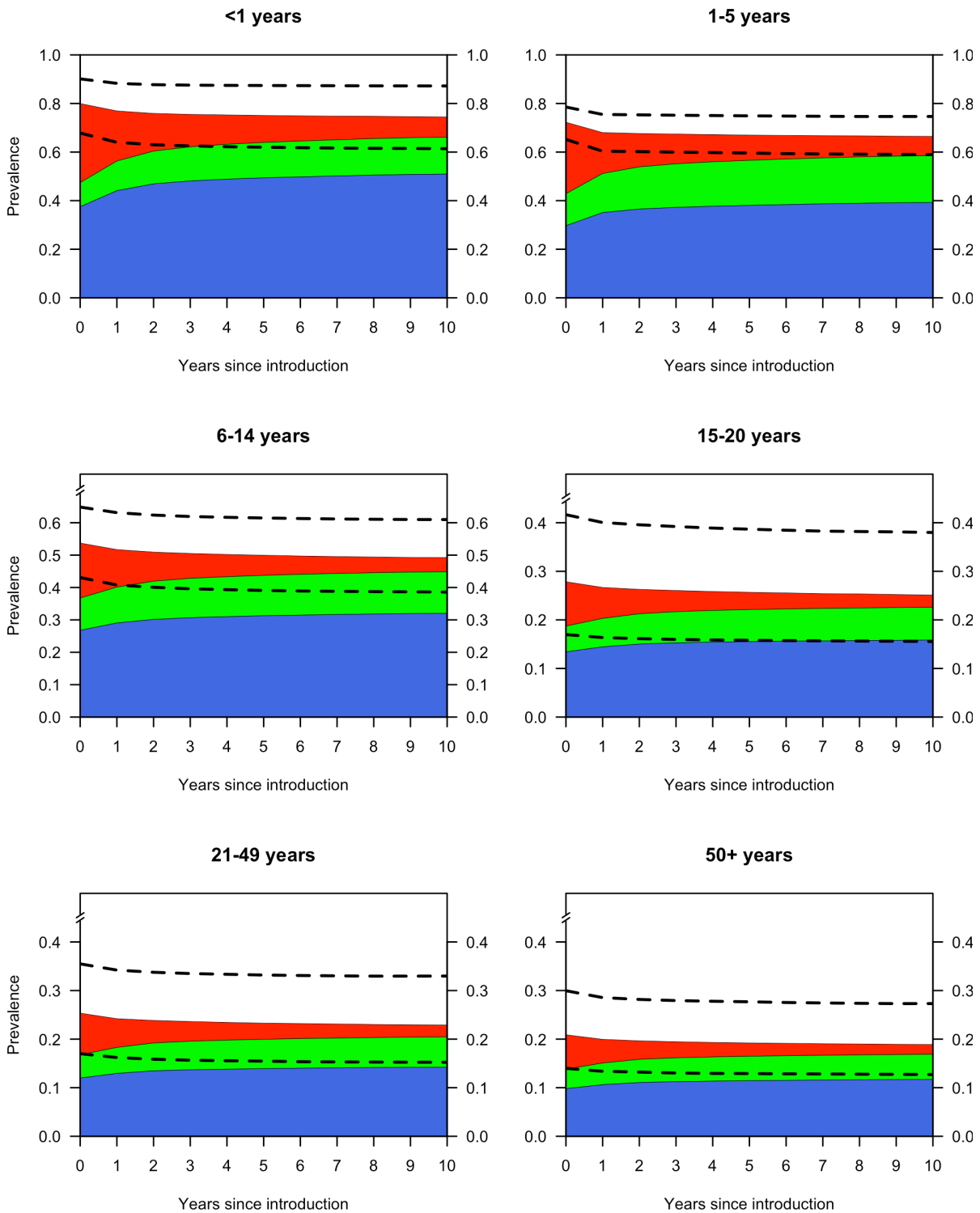
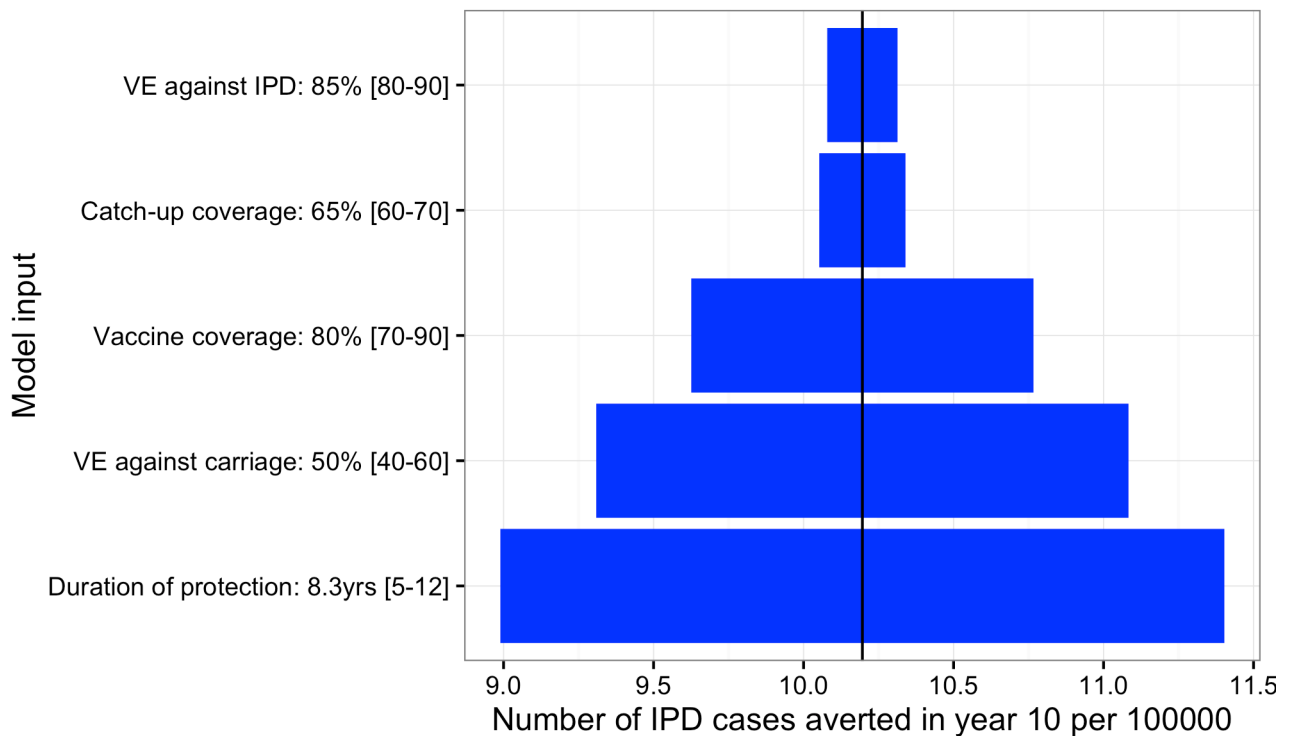
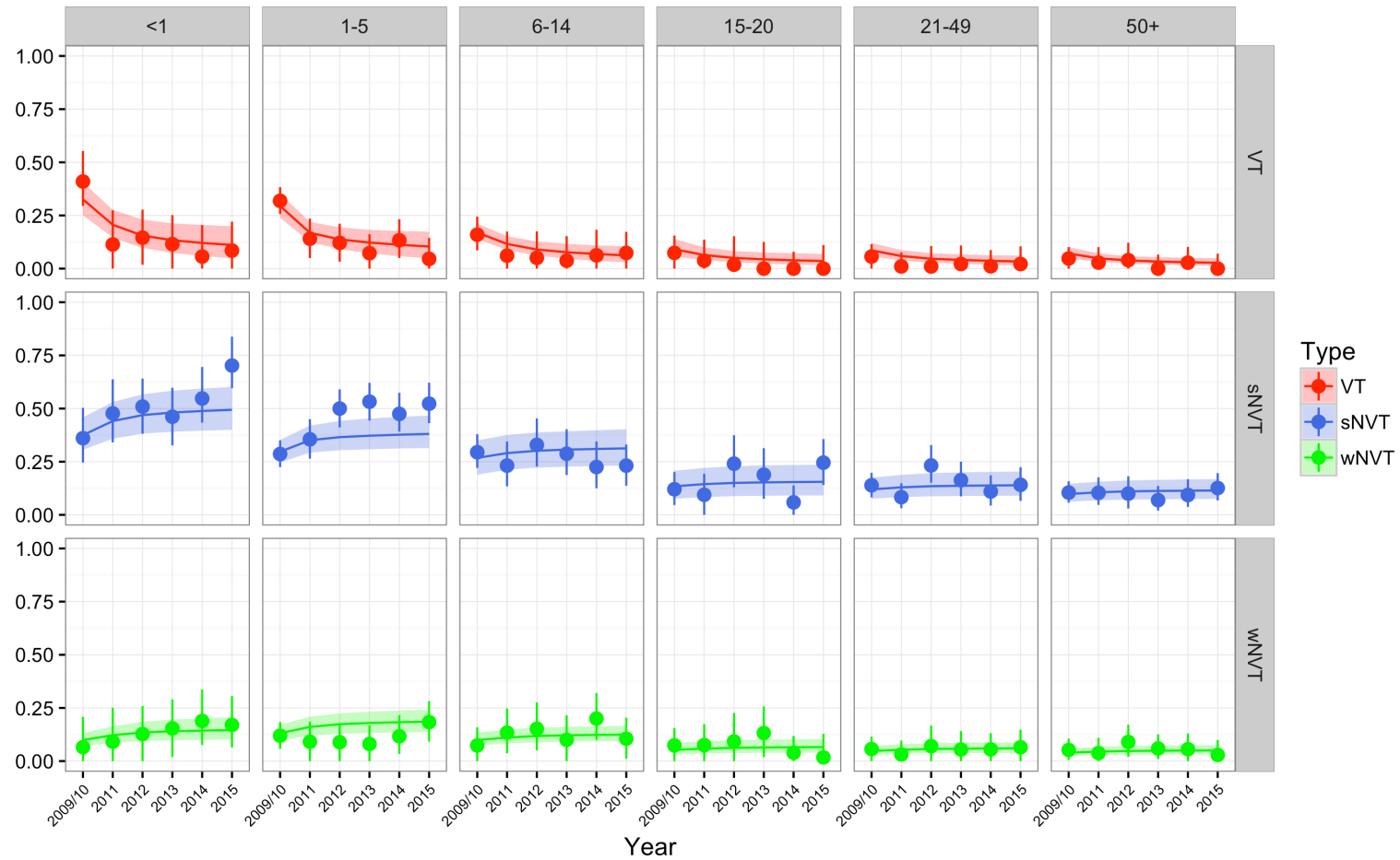

Figure 3: Model projections on carriage prevalence over 10 years by age group.

Projected cumulative prevalence of pneumococcal carriage of VT (red), strong NVT (blue) and weak NVT (lime green) by age group over time since vaccine introduction. For each age group, the dotted lines show the 95% predictive intervals for the overall prevalence of pneumococcal carriage.



Supplementary Figure S1: Sensitivity analysis for inputs. The impact of uncertainties in four selected model inputs (y-axis) on the predicted number of averted IPD cases per year per 100,000 in year 10 after vaccine introduction (x-axis). The vertical line at the middle of the plot marks the mean number of IPD cases (10.2) averted in year 10 per 100,000 when all the shown inputs are at their respective means. The horizontal bars correspond to predicted ranges of the number of averted IPD cases when each input variable is sampled from a normal distribution, with respective 95% ranges as given in the brackets. The number of averted cases is based on a linear model approximation of the simulation output.



Supplementary Figure S2: Observed and predicted carriage prevalence over time, under constant population. Observed (circular dots with 95% credible intervals shown by spikes) and predicted (lines with 95% predictive intervals shown by shaded areas) carriage prevalence of VT (red), strong NVT (blue) and weak NVT (lime green) over time since vaccine introduction. The age groups are labelled at the panel titles.

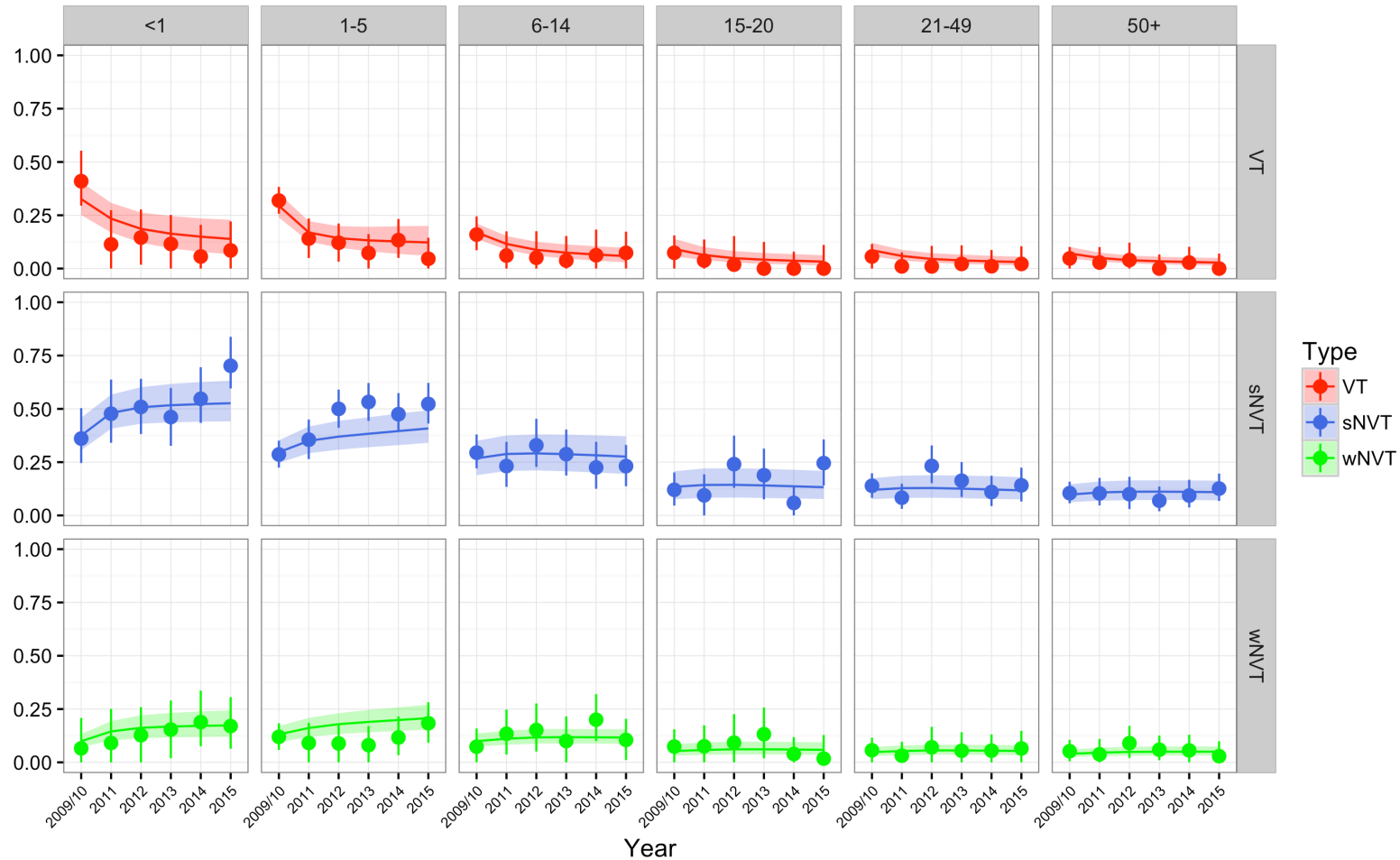

Supplementary Figure S3: Observed and predicted carriage prevalence over time, under growing population. Observed (circular dots with 95% credible intervals shown by spikes) and predicted (lines with 95% predictive intervals shown by shaded areas) carriage prevalence of VT (red), strong NVT (blue) and weak NVT (lime green) over time since vaccine introduction. The age groups are labelled at the panel titles.

Appendix

Chapter 1. Prevalence of pneumococcal carriage in Kilifi, Kenya.

Serotypes were grouped as vaccine-types (VT, those included in PCV10), strong non-vaccines serotypes (23B, 11A, 15A, 6A, 16F, 35B, 10A, 13, 23A, 19A, 21, 34, 15B/C; see appendix chapter 2), and weak non-vaccine-types (the rest). The data came from two surveys of pneumococcal carriage in Kilifi, Kenya (2009-2010) [5]. The reported prevalences in table A.1 below are age-standardised, with the KHDSS reference population as at 1 Jan 2010 (midpoint of the two survey years), since the surveys were based on 10 age strata collapsed to six in the current analysis. Based on the total number of individuals in each age group, the numbers of carriers of VTs, strong NVTs and weak NVTs as presented in this table were calculated to match the estimated standardised carriage prevalence of the respective serotype groups.

Table A.1: Prevalence of pneumococcal carriage and the serotype distribution by age group.

<i>Age group (years)</i>	<i>Number of carriers N (%)</i>	<i>VT N (%)</i>	<i>Strong NVT N (%)</i>	<i>Weak NVT N (%)</i>	<i>Total N (%)</i>
<1	51 (83.6)	25 (41.0)	22 (36.1)	4 (6.6)	61 (100.0)
1-5	200 (72.5)	88 (31.9)	79 (28.6)	33 (12.0)	276 (100.0)
6-14	86 (52.8)	26 (16.0)	48 (29.4)	12 (7.4)	163 (100.0)
15-20	29 (26.9)	8 (7.4)	13 (12.0)	8 (7.4)	108 (100.0)
21-49	49 (25.3)	11 (5.7)	27 (13.9)	11 (5.7)	194 (100.0)
≥50	43 (20.5)	10 (4.8)	22 (10.5)	11 (5.2)	210 (100.0)

Chapter 2. Division of serotypes into VTs, strong NVTs and weak NVTs

Vaccine serotypes (VTs) are serotype in the PCV-10 vaccine (1, 4, 5, 6B, 7F, 9V, 14, 18C, 19F and 23F). The non-vaccine serotypes (NVTs) were classified as *weak* or *strong* based on their susceptibility to competition (a measure of competitive strength of a serotype defined as the rate at which individuals carrying that serotype switch to carry another serotype, relative to the rate at which that other serotype colonizes an uncolonised person) and carriage incidence, as estimated in a prior field study within KHDSS¹. In our model strong NVTs were categorised as those less susceptible to competition by having a lower susceptibility; NVTs with susceptibility estimate of 1 and below were considered strong. These serotypes were: 23B, 11A, 15A, 6A, 16F, 35B, 10A, 13, 23A 19A and 21, ordered by increasing susceptibility to competition. Two NVTs (34, 15B/C) were also classified as strong for their higher carriage incidences than many of the ones chosen on the basis of susceptibility. The remaining NVTs were classified as weak (Table A.2).

Table A.2: Categorisation of serotypes

Serotype	Serotype group	Susceptibility	Incidence (per 1000 days)	Duration of carriage (days)
19F	VTs	0.481	3.07	88.5
23B	strong NVTs	0.523	0.93	60.3
6B	VTs	0.524	1.77	115.6
11A	strong NVTs	0.544	1.08	72.3
15A	strong NVTs	0.560	0.65	55.0
6A	strong NVTs	0.580	2.51	123.8
23F	VTs	0.586	1.46	67.8
16F	strong NVTs	0.703	0.44	52.5
9V	VTs	0.752	0.88	44.6
35B	strong NVTs	0.813	1.15	88.1
10A	strong NVTs	0.874	0.97	65.2
23A	strong NVTs	0.910	0.34	54.2
14	VTs	0.911	1.36	69.5
19A	strong NVTs	0.956	0.87	58.9
13	strong NVTs	0.969	0.79	70.4

18C	VTs	0.970	0.49	49.7
21	strong NVTs	1.059	0.31	93.0
34	strong NVTs	1.166	0.71	76.3
19B	weak NVTs	1.176	0.54	63.5
1	VTs	1.183	0.25	31.0
35A	weak NVTs	1.191	0.29	61.9
15B	strong NVTs	1.353	1.25	51.8
other	weak NVTs	1.366	1.86	41.3
7C	weak NVTs	1.400	0.62	40.1
15C	strong NVTs	1.503	1.08	56.3
3	weak NVTs	1.519	0.74	40.8
20	weak NVTs	1.533	0.59	28.3
33B	weak NVTs	2.074	0.38	29.6

¹ Lipsitch M, Abdullahi O, D'amour A, Xie W, Weinberger DM, Tchetgen ET, et al. Estimating Rates of Carriage Acquisition and Clearance and Competitive Ability for Pneumococcal Serotypes in Kenya With a Markov Transition Mode. *Epidemiology* 2012;23:1–10.

Chapter 3. Dynamic model structure in equations

All parameters and states in the equations below have been defined in the main article (see also Figure 1). The quantities b , μ_i and $P(t)$ denote the birth rate, age-specific death rate and population size at time t , respectively. The term $k_i(t)$ denotes the rate of movement to the next age group from the i^{th} age group (see *Appendix chapter 6*). The term $b * P(t)$ in the first equation applies only to the first age group (< 1 year olds). In the first age group, all terms with $+k_{i-1}(t)$ denoting movement into the age group, by aging, from a lower age category should be excluded from all equations. In the last age group, ≥ 50 years, all terms with $-k_i(t)$ denoting movement from the age group by aging should be excluded from all equations.

$$\frac{dS_i(t)}{dt} = r_{Vi} * V_i(t) + r_{Nsi} * N_{si}(t) + r_{Nwi} * N_{wi}(t) - S_i(t) * (\lambda_{Vi}(t) + \lambda_{Nsi}(t) + \lambda_{Nwi}(t)) - \eta * S_i(t) \\ + \varphi * S_i^{(v)}(t) + b * P(t) - \mu_i * S_i(t) - k_i(t) * S_i(t) + k_{i-1}(t) * S_{i-1}(t)$$

$$\begin{aligned}\frac{dV_i(t)}{dt} &= r_{Nsi} * B_{Si}(t) + r_{Nwi} * B_{wi}(t) - r_{Vi} * V_i(t) + \lambda_{Vi}(t) * S_i(t) - V_i(t) \\ &\quad * (c_v * \lambda_{Nsi}(t) + c_v * \lambda_{Nwi}(t)) - \eta * V_i(t) + \varphi * V_i^{(v)}(t) - \mu_i * V_i(t) - k_i(t) * V_i(t) \\ &\quad + k_{i-1}(t) * V_{i-1}(t)\end{aligned}$$

$$\begin{aligned}\frac{dN_{Si}(t)}{dt} &= r_{Nwi} * N_{swi}(t) + r_{Vi} * B_{Si}(t) - r_{Nsi} * N_{Si}(t) + \lambda_{Nsi}(t) * S_i(t) - N_{Si}(t) \\ &\quad * (c_s * \lambda_{Vi}(t) + c_s * \lambda_{Nwi}(t)) - \eta * N_{Si}(t) + \varphi * N_{Si}^{(v)}(t) - \mu_i * N_{Si}(t) - k_i(t) * N_{Si}(t) \\ &\quad + k_{i-1}(t) * N_{Si-1}(t)\end{aligned}$$

$$\begin{aligned}\frac{dN_{wi}(t)}{dt} &= r_{Nsi} * N_{swi}(t) + r_{Vi} * B_{wi}(t) - r_{Nwi} * N_{wi}(t) + \lambda_{Nwi}(t) * S_i(t) - N_{wi}(t) \\ &\quad * (c_w * \lambda_{Vi}(t) + c_w * \lambda_{Nsi}(t)) - \eta * N_{wi}(t) + \varphi * N_{wi}^{(v)}(t) - \mu_i * N_{wi}(t) - k_i(t) * N_{wi}(t) \\ &\quad + k_{i-1}(t) * N_{wi-1}(t)\end{aligned}$$

$$\begin{aligned}\frac{dN_{swi}(t)}{dt} &= c_w * \lambda_{Nsi}(t) * N_{wi}(t) + c_s * \lambda_{Nwi}(t) * N_{Si}(t) - (r_{Nsi} + r_{Nwi}) * N_{swi}(t) - \eta * N_{swi}(t) + \varphi \\ &\quad * N_{swi}^{(v)}(t) - \mu_i * N_{swi}(t) - k_i(t) * N_{swi}(t) + k_{i-1}(t) * N_{swi-1}(t)\end{aligned}$$

$$\begin{aligned}\frac{dB_{Si}(t)}{dt} &= c_v * \lambda_{Nsi}(t) * V_i(t) + c_s * \lambda_{Vi}(t) * N_{Si}(t) - (r_{Nsi} + r_{Vi}) * B_{Si}(t) - \eta * B_{Si}(t) + \varphi * B_{Si}^{(v)}(t) - \mu_i \\ &\quad * B_{Si}(t) - k_i(t) * B_{Si}(t) + k_{i-1}(t) * B_{Si-1}(t)\end{aligned}$$

$$\begin{aligned}\frac{dB_{wi}(t)}{dt} &= c_v * \lambda_{Nwi}(t) * V_i(t) + c_w * \lambda_{Vi}(t) * N_{wi}(t) - (r_{Nwi} + r_{Vi}) * B_{wi}(t) - \eta * B_{wi}(t) + \varphi * B_{wi}^{(v)}(t) \\ &\quad - \mu_i * B_{wi}(t) - k_i(t) * B_{wi}(t) + k_{i-1}(t) * B_{wi-1}(t)\end{aligned}$$

$$\begin{aligned}\frac{dS_i^{(v)}(t)}{dt} &= r_{Vi} * V_i^{(v)}(t) + r_{Nsi} * N_{Si}^{(v)}(t) + r_{Nwi} * N_{wi}^{(v)}(t) - S_i^{(v)}(t) \\ &\quad * ((1 - \varepsilon) * \lambda_{Vi}(t) + \lambda_{Nsi}(t) + \lambda_{Nwi}(t)) + \eta * S_i(t) - \varphi * S_i^{(v)}(t) - \mu_i * S_i^{(v)}(t) - k_i(t) \\ &\quad * S_i^{(v)}(t) + k_{i-1}(t) * S_{i-1}^{(v)}(t)\end{aligned}$$

$$\begin{aligned}\frac{dV_i^{(v)}(t)}{dt} &= r_{Nsi} * B_{Si}^{(v)}(t) + r_{Nwi} * B_{wi}^{(v)}(t) - r_{Vi} * V_i^{(v)}(t) + (1 - \varepsilon) * \lambda_{Vi}(t) * S_i^{(v)}(t) - V_i^{(v)}(t) \\ &\quad * (c_v * \lambda_{Nsi}(t) + c_v * \lambda_{Nwi}(t)) + \eta * V_i^{(v)}(t) - \varphi * V_i^{(v)}(t) - \mu_i * V_i^{(v)}(t) - k_i(t) \\ &\quad * V_i^{(v)}(t) + k_{i-1}(t) * V_{i-1}^{(v)}(t)\end{aligned}$$

$$\begin{aligned} \frac{dN_{si}^{(v)}(t)}{dt} &= r_{Nwi} * N_{swi}^{(v)}(t) + r_{Vi} * B_{si}^{(v)}(t) - r_{Nsi} * N_{si}^{(v)}(t) + \lambda_{Nsi}(t) * S_i^{(v)}(t) - N_{si}^{(v)}(t) \\ &\quad * ((1 - \varepsilon) * c_s * \lambda_{Vi}(t) + c_s * \lambda_{Nwi}(t)) + \eta * N_{si}(t) - \varphi * N_{si}^{(v)}(t) - \mu_i * N_{si}^{(v)}(t) - k_i(t) \\ &\quad * N_{si}^{(v)}(t) + k_{i-1}(t) * N_{si-1}^{(v)}(t) \end{aligned}$$

$$\begin{aligned} \frac{dN_{wi}^{(v)}(t)}{dt} &= r_{Nsi} * N_{swi}^{(v)}(t) + r_{Vi} * B_{wi}^{(v)}(t) - r_{Nwi} * N_{wi}^{(v)}(t) + \lambda_{Nwi}(t) * S_i^{(v)}(t) - N_{wi}^{(v)}(t) \\ &\quad * ((1 - \varepsilon) * c_w * \lambda_{Vi}(t) + c_w * \lambda_{Nsi}(t)) + \eta * N_{wi}(t) - \varphi * N_{wi}^{(v)}(t) - \mu_i * N_{wi}^{(v)}(t) - k_i(t) \\ &\quad * N_{wi}^{(v)}(t) + k_{i-1}(t) * N_{wi-1}^{(v)}(t) \end{aligned}$$

$$\begin{aligned} \frac{dN_{swi}^{(v)}(t)}{dt} &= c_w * \lambda_{Nsi}(t) * N_{wi}^{(v)}(t) + c_s * \lambda_{Nwi}(t) * N_{si}^{(v)}(t) - (r_{Nsi} + r_{Nwi}) * N_{swi}^{(v)}(t) + \eta * N_{swi}(t) - \varphi \\ &\quad * N_{swi}^{(v)}(t) - \mu_i * N_{swi}^{(v)}(t) - k_i(t) * N_{swi}^{(v)}(t) + k_{i-1}(t) * N_{swi-1}^{(v)}(t) \end{aligned}$$

$$\begin{aligned} \frac{dB_{si}^{(v)}(t)}{dt} &= c_v * \lambda_{Nsi}(t) * V_i^{(v)}(t) + (1 - \varepsilon) * c_s * \lambda_{Vi}(t) * N_{si}^{(v)}(t) - (r_{Nsi} + r_{Vi}) * B_{si}^{(v)}(t) + \eta * B_{si}(t) \\ &\quad - \varphi * B_{si}^{(v)}(t) - \mu_i * B_{si}^{(v)}(t) - k_i(t) * B_{si}^{(v)}(t) + k_{i-1}(t) * B_{si-1}^{(v)}(t) \end{aligned}$$

$$\begin{aligned} \frac{dB_{wi}^{(v)}(t)}{dt} &= c_v * \lambda_{Nwi}(t) * V_i^{(v)}(t) + (1 - \varepsilon) * c_w * \lambda_{Vi}(t) * N_{wi}^{(v)}(t) - (r_{Nwi} + r_{Vi}) * B_{wi}^{(v)}(t) + \eta * B_{wi}(t) \\ &\quad - \varphi * B_{wi}^{(v)}(t) - \mu_i * B_{wi}^{(v)}(t) - k_i(t) * B_{wi}^{(v)}(t) + k_{i-1}(t) * B_{wi-1}^{(v)}(t) \end{aligned}$$

The forces of infection by VTs, weak NVTs, and strong NVTs are defined by equations 1, 2 and 3 below:

$$\lambda_{Vi}(t) = \sum_j \beta_{ij} * (V_j(t) + B_{sj}(t) + B_{wj}(t) + V_j^{(v)}(t) + B_{sj}^{(v)}(t) + B_{wj}^{(v)}(t)) \quad (1)$$

$$\lambda_{Nwi}(t) = \sum_j \beta_{ij} * (N_{wj}(t) + N_{swj}(t) + B_{wj}(t) + N_{wj}^{(v)}(t) + N_{swj}^{(v)}(t) + B_{wj}^{(v)}(t)) \quad (2)$$

$$\lambda_{Nsi}(t) = \sum_j \beta_{ij} * (N_{sj}(t) + N_{swj}(t) + B_{sj}(t) + N_{sj}^{(v)}(t) + N_{swj}^{(v)}(t) + B_{sj}^{(v)}(t)) \quad (3)$$

where the β_{ij} is the per capita transmission rate between an individual (carrier) in age class j and a (susceptible) individual in age class i . These rates are expressed as a function of the social mixing matrix U_{ij} as $\beta_{ij} = \frac{q_i * U_{ij}}{y_i}$, where the age group specific proportionality factor q_i scales the rate of social contacts into infectious contacts and represents the susceptibility to acquisition of carriage, given a contact¹. The elements of the matrix U_{ij} are the mean numbers of social contacts an individual in age class j makes with individuals in age class i per unit time and y_i is the population size of the i^{th} age group. The unknown scaling factors q_i were allowed differ across age groups, based on the initial observation that the pre-vaccination prevalence of carriage in the three first age groups was significantly different but the prevalence in each of the age groups above the age of 15 years were similar despite the varying average rates of social contacts.

Chapter 4. Clearance rates

To obtain the average age-group specific clearance rate for each serotype group, a weighted mean of the clearance rates of individual serotypes in the group was computed. The incidences of the individual serotypes were used as weights. For infants, the clearance rates were computed for the strong NVTs and weak NVTs. For 1-5 and ≥ 6 year olds, a single clearance rate was computed for the weak and strong NVTs by taking the weighted average of the clearance rates of all NVTs.

¹ Wallinga J, Teunis P, Kretzschmar M. Using data on social contacts to estimate age-specific transmission parameters for respiratory-spread infectious agents. *Am J Epidemiol* 2006;164:936–44. doi:10.1093/aje/kwj317.

Table A.3: Clearance rates (per month) by age group and serotype group.

Age group (years)	Serotype group		
	VT	Strong NVT	Weak NVT
<1	0.271	0.285	0.601
1-5	0.546	0.662	0.662
≥6	0.934	0.928	0.928

Chapter 5. Estimation of the model parameters

The model was calibrated to the age-specific prevalence and serotype distributions in the pre-vaccination era (Appendix chapter 1), assuming a steady-state distribution of carriage in the population. Since the calibration data recorded only one serotype for each carrying individual, there were only four carriage states (S_i, V_i, N_{si} and N_{wi}) on which to define the likelihood. The model output has three additional states (N_{swi}, B_{si}, B_{wi}). Therefore, for the age groups 6-14, 15-20, 21-49 and ≥50 years, the model output for the seven carriage states was collapsed into four states as follows:

$$V'_i = V_i + 0.5 * (B_{si} + B_{wi})$$

$$N'_{si} = N_{si} + 0.5 * (B_{si} + N_{swi})$$

$$N'_{wi} = N_{wi} + 0.5 * (B_{wi} + N_{swi})$$

This choice carries the assumption that in a doubly-colonised individual either of the two colonising serotypes was detected with 50% probability.

For the two youngest age groups, <1 and 1-5 years, data on the proportion of doubly-colonised individuals among pneumococcal carriers were available from a study in Kenya. Consequently, in the numerical estimation algorithm (see below), the proportion ρ “of doubly-colonised individuals in <6 year olds was randomly generated from a normal distribution with mean 24% and standard deviation of 3.5%. For any realisation of the

proportion, the expected number of doubly-colonised individuals in the first two age groups is then $D_{obs} = \rho * (V + N_s + N_w)$. The observed data for the two youngest age groups was adjusted to include five classes of carriage by

$$X_i = \{S_i, V_i(1 - \rho), N_{si}(1 - \rho), N_{wi}(1 - \rho), D_{obs\ i}\}$$

Accordingly, the model output for the carriage states was collapsed into 5 states by adding together the doubly-colonised states ($D_i = B_{si} + B_{wi} + N_{swi}$) so that collapsed model output was $\{S_i, V_i, N_{si}, N_{wi}, D_i\}$ for <6 year olds.

Denote the vectors containing the number of individuals in each j^{th} carriage status in the i^{th} age group in the empirical calibration data by X_{ij} . Denote the vectors containing the model output of the proportions of the carriage status in the i^{th} age group by $P_i(\theta)$. Vector θ contains all model parameters that are estimated from the data.

Denote the set of model parameters by $\theta = \{q_1, q_2, q_3, q_4, q_5, q_6, c_{v0}, c_{s0}, c_{w0}, c_{vw}, c_s\}$, where $q_i (i = 1,2,3,4,5,6)$ are the proportionality factors that scale the rate of social contacts into infectious contacts and $c_{v0}, c_{s0}, c_{w0}, c_{vw}, c_s$ are the competition parameters. The likelihood function of the model parameters is based on a multinomial distribution. In particular, the counts X_{ij} in the i^{th} age group follow a multinomial distribution, so that their log-likelihood based on the observations is

$$\sum_{i=1}^6 \sum_{j=1}^{k_i} X_{ij} \log(P_{ij}(\theta)),$$

where $k_i = 5$ for the two youngest age groups and 4 otherwise. For any given set, θ , the model equations (Appendix chapter 3) were solved to find the stationary numbers of individuals in each of the pre-vaccination compartments, from these numbers the age group specific carriage distribution in the four (or five for the first two age groups)

compartments was derived as the model output. The routine BBsolve in R¹ was used to solve the system of equations for a stationary solution.

The Metropolis-Hastings algorithm was used to draw samples from the posterior distributions of the parameters. A non-informative (uniform distribution in the range 0-1) prior was used for each parameter and the posterior distributions of the parameters were summarised to obtain point estimates (posterior mean) and probability (credibility) intervals for parameters included in θ . 100,000 MCMC iterations were used. After a burn-in of 40,000 the remaining samples, which were stationary, were thinned to 2000; the posterior means and 95% credible intervals of the parameters were calculated from these samples.

¹ Varadhan R, Gilbert PD. BB : An R Package for Solving a Large System of Nonlinear Equations and for Optimizing a High-Dimensional Nonlinear Objective Function. October 2009;32:1–26.

Chapter 6. Population model

Population under constant mortality across age groups

Denote the age-specific mortality, i.e., the per capita rate of death by $v(a)$. The steady-

state age distribution is $f(a) = \frac{\exp(-\int_0^a v(u)du)}{A}$, where the normalising constant $A =$

$$\int_0^\infty \exp(-\int_0^a v(u)du)da.$$

In case of constant mortality across age groups $v(a) = v$ and the steady state age distribution is exponential, i.e., $f(a) = v * \exp(-v * a)$. Denote the age group boundaries $t = (t_1, \dots, t_7) = (0, 1, 6, 15, 21, 50, \infty)$ (years) and the observed numbers of individuals in each of the age groups in the KHDSS in the year before vaccine introduction as $N_i = (N_1, \dots, N_6)$. To estimate a constant rate v , the steady-state age distribution was fitted to the observed data based on a multinomial likelihood for v :

$$\prod_{i=1}^6 [\exp(-vt_i) - \exp(-vt_{i+1})]^{N_i}.$$

The maximum likelihood estimate for v was found to be 0.046 per year (or 1.25E-04 per day). Based on this estimate, the fitted proportion of individuals in each of the age groups is shown in Table A.4.

Table A.4: Observed and model age distribution in the KDHSS before vaccine introduction. A constant birth and death rate was assumed.

<i>Age Group (years)</i>	<i>Number of individuals</i>	<i>Observed Proportion</i>	<i>Model Proportion</i>
<1	9,424	0.037	0.045
1-5	45,727	0.180	0.195
6-14	68,648	0.271	0.256
15-20	32,815	0.129	0.121
21-49	72,705	0.287	0.281
≥50	24,288	0.096	0.102

Under the assumptions of a constant death rate, in age group i with upper bound $a_i = (a_1, \dots, a_5) = (1,6,15,21,50)$ years, the per capita rate of aging is calculated as:

$$k_i(t) = v * \exp(-v * a_i) \text{ for all } t.$$

Individuals in the age group ≥ 50 do not move from that age group due to aging.

Population under age-specific mortality rates

Predictions of pneumococcal prevalence and invasive disease were done under an alternative assumption of a growing population, based the crude birth rate (8.78E-05 per

day) and age-specific death rates (Table A.5) in the KHDSS population. This section summarises how the per capita rate of aging was derived under this model.

Denote the age-specific per capita mortality rate as $m(a)$ and the number of individuals of age a at calendar time t by $N(a, t)$. The time evolution of $N(a, t)$ is defined through the following equation:

$$\frac{dN(a, t)}{dt} = -N(a, t)m(a) \quad (1)$$

With boundary conditions (i) $N(0, t) = N(t)\beta$ and (ii) $N(a, 0) = N(0)g(a)$, where β is the per capita rate of birth, $N(t)$ is the total population at time t and $g(a)$ is the probability density of age at time 0 estimated from the KHDSS data as an exponential distribution so that $g(a) = v * \exp(-v * a)$.

The rate of individuals of age a_i (in the i^{th} age group) moving to the next age group at time t is given by the solution to equation (1) and its boundary conditions. For the solution, we write $M(a_i) = \exp(-\int_0^{a_i} m(u)du)$ for survival up to age a_i , $N(t - a_i)\beta$ for the number of individuals (per time unit) born at time $t - a_i$ (if $t > a_i$), and $N(0)g(a_i - t)$ for the number of individuals (per time unit) of age $a_i - t$ (if $t \leq a_i$). The former deals with individuals born after the start of the simulation while the latter deals with individuals who belonged to the initial population at time $t = 0$. The following numbers of individuals of age a_i moving to the next age group at time t are obtained:

$$N(t - a_i)\beta M(a_i), t > a_i,$$

$$N(0)g(a_i - t) \frac{M(a_i)}{M(a_i - t)}, t \leq a_i$$

The division of the second expression by $M(a_i - t)$ corresponds to the survival probability being conditioned on the individual(s) being alive at age $a_i - t$.

The total numbers of individuals moved to the next age group were further divided according to the proportions of the 14 epidemiological states in the transmission model at time t to move an appropriate number of individuals to the next age group at each of the states.

In the discretized model, the per capita rate of aging is calculated as:

$$k_i(t) = \begin{cases} \frac{N(t-a_i)\beta M(a_i)}{w_i(t)} & \text{if } t > a_i \\ N(0)g(a_i - t) \frac{M(a_i)}{M(a_i-t)w_i(t)} & \text{if } t \leq a_i \end{cases},$$

where $w_i(t)$ is the number of individuals in age group i at time t .

Table A.5: Age specific death rates (per capita per day) in the KHDSS population. These are the rates used for $m(a)$ in the above equations.

Age group	<1	1-5	6-14	15-20	21-49	≥50
Death rate	7.18E-05	6.55E-06	2.73E-06	3.51E-06	1.21E-05	7.31E-05

Chapter 7. Sensitivity analysis

Simulation under a growing population with a catch-up dose in <5 year olds

Table A.6: Prediction of carriage prevalence before and 10-years post vaccination by age group. The table presents the predicted mean levels and 95% predictive intervals. A growing population and vaccine introduction with a catch-up dose were assumed.

Age group	Pre-vaccination				10 years post-vaccination			
	Carriage prevalence	VT	Strong NVT	Weak NVT	Carriage prevalence	VT	Strong NVT	Weak NVT
<1	80.8 (67.8-90.1)	32.6 (25.1-40.5)	37.5 (30.6-45.8)	9.9 (7.1-13.2)	82.9 (71.1-91.5)	10.5 (2.2-21.0)	53.6 (44.1-65.1)	17.6 (12.1-25.6)
1-5	72.5 (65.2-78.5)	29.5 (23.9-35.2)	29.7 (24.6-35.2)	13.1 (9.6-17.0)	74.6 (67.5-80.5)	9.7 (2.1-19.2)	42.1 (34.6-51.6)	21.8 (16.1-28.7)
6-14	54.0 (43.1-64.8)	17 (13.9-21.2)	26.8 (18.9-35.0)	9.9 (7.4-13.5)	45.9 (34.0-57.7)	4.4 (0.9-9.1)	28.8 (20.3-38.3)	12.2 (9.1-16.4)
15-20	27.9 (17.0-41.7)	9.1 (5.7-13.9)	13.4 (7.6-20.7)	5.3 (3.1-8.6)	18.4 (10.9-29.1)	2.0 (0.4-4.8)	11.2 (6.5-18.2)	5.1 (3.0-8.3)
21-49	25.5 (17.0-35.5)	8.6 (5.8-12.1)	12.0 (7.6-17.5)	4.8 (3.0-7.2)	16.9 (10.6-25.9)	2.0 (0.4-4.4)	10.0 (6.3-15.9)	4.7 (2.8-7.2)
≥50	21.0 (14.0-30.0)	7.1 (4.7-10.1)	9.8 (6.2-14.6)	4.0 (2.6-6.0)	17.4 (11.5-25.3)	2.0 (0.4-4.2)	10.4 (6.8-15.6)	4.8 (3.1-7.3)
Overall	44.4 (40.2-48.9)	15.9 (13.3-18.7)	20.4 (16.8-24.2)	44.4 (40.2-48.9)	34.9 (29.9-40.2)	4.0 (0.8-8.0)	21.1 (17.2-25.6)	9.6 (7.3-12.2)

Table A.7: Predictions of invasive pneumococcal disease (IPD) incidence before and 10-years post vaccination by age group. The table presents the predicted mean levels and 95% predictive intervals (PI). A growing population and vaccine introduction with a catch-up dose were assumed.

Age groups	Pre-vaccination IPD incidence			10 years post-vaccination IPD incidence (95% PI)			IRR
	VT	Strong NVT	Weak NVT	VT	Strong NVT	Weak NVT	
<1	67.0	21.0	7.1	8.6 (1.8, 18.3)	41.1 (32.2, 55.0)	14 (10.7, 19.0)	0.7 (0.6, 0.8)
1-5	39.3	5.1	0.7	8.1 (1.6, 17.4)	8.8 (7.2, 11.2)	1.3 (1.0, 1.7)	0.4 (0.3, 0.6)
6-14	7.3	1.0	0.0	1.5 (0.3, 3.1)	1.1 (0.9, 1.3)	0.0 (0.0, 0.0)	0.3 (0.2, 0.5)
15-20	1.0	0.0	0.0	0.2 (0.0, 0.4)	0.0 (0.0, 0.0)	0.0 (0.0, 0.0)	0.2 (0.0, 0.4)
21-49	4.2	0.9	0.0	0.9 (0.2, 1.7)	0.8 (0.7, 0.9)	0.0 (0.0, 0.0)	0.3 (0.2, 0.5)
≥50	9.2	2.8	4.1	2.5 (0.5, 4.7)	3.0 (2.7, 3.5)	4.9 (4.2, 6.0)	0.7 (0.5, 0.8)
Overall	14.8	2.7	0.9	2.4 (0.5, 4.9)	3.3 (2.8, 4.2)	1.1 (0.9, 1.4)	0.4 (0.3, 0.5)

Chapter 8. Pre-vaccination IPD Incidence

Table A.8: Pre-vaccination incidence of invasive pneumococcal disease (IPD) and case-to-carrier ratios by serotype group and age group. The IPD cases are from the KHDSS hospital surveillance data.

Age group (years)	Cases			IPD incidence* (per 100,000 per year)			Case-to-carrier ratio** (per 10,000)		
	VT	Strong NVT	Weak NVT	VT	Strong NVT	Weak NVT	VT	Strong NVT	Weak NVT
<1	19	6	2	67.0	21.0	7.1	4.28 (3.03-6.16)	1.02 (0.73 -1.40)	0.90 (0.65-1.31)
1-5	54	7	1	39.3	5.1	0.7	1.44 (1.11-1.91)	0.15 (0.12-0.20)	0.06 (0.04-0.09)
6-14	15	2	0	7.3	1.0	0.0	0.32 (0.24-0.40)	0.02 (0.02-0.04)	0.00 (0.00-0.00)
15-20	1	0	0	1.0	0.0	0.0	0.09 (0.06-0.15)	0.00 (0.00-0.00)	0.00 (0.00-0.00)
21-49	9	2	0	4.2	0.9	0.0	0.40 (0.27-0.61)	0.06 (0.04-0.10)	0.00 (0.00-0.00)
≥50	7	2	3	9.2	2.8	4.1	1.07 (0.73-1.65)	0.23 (0.15-0.38)	0.87 (0.57-1.37)

(*) Average across 3 years (2008,2009,2010) to represent pre-vaccination IPD incidence.

(**) These are estimated based on modelled carriage incidence and the observed IPD incidence. Figures in the brackets represent the 95% credible intervals

Chapter 3: Research paper 2

Title: Pneumococcal conjugate vaccine induced IgG and nasopharyngeal carriage of pneumococci: Hyporesponsiveness and immune correlates of protection for carriage

Author(s): John Ojal, Laura L. Hammitt, John Gaitho, J. Anthony G. Scott, David Goldblatt.

Journal/Publisher: Vaccine, 2017 Aug 16; 35(35 Pt B): 4652-4657

Type of publication: Original contribution

Stage of publication: In press

Academic peer-reviewed: Yes

Copyright: Open access

Candidate's role:

This manuscript drew data from two prior clinical trials that I had analysed and co-authored. I conceived the additional use of the data to answer the questions on hyporesponsiveness and correlates of protection together with Prof. David Goldblatt. I analysed the data using statistical models and generated all the results presented in the manuscript. I wrote the first draft of the manuscript, reviewed and responded to all comments from co-authors as well as those from journal reviewers to generate the published manuscript.

Candidate's signature: 

Supervisor or senior author's signature to confirm Candidates role:



Pneumococcal conjugate vaccine induced IgG and nasopharyngeal carriage of pneumococci: Hyporesponsiveness and immune correlates of protection for carriage

John Ojal^{1,3}, Laura L. Hammitt^{1,2}, John Gaitho¹, J. Anthony G. Scott^{1,3}, David Goldblatt⁴

1. KEMRI-Wellcome Trust Research Programme, Kilifi, Kenya

2. Department of International Health, Johns Hopkins Bloomberg School of Public Health, Baltimore, Maryland, USA.

3. Department of Infectious Disease Epidemiology, London School of Hygiene & Tropical Medicine, London, United Kingdom.

4. Great Ormond Street Institute of Child Health, University College, London, United Kingdom.

Key words: pneumococcal conjugate vaccine; nasopharyngeal carriage;

Kenya; hyporesponsiveness; correlates of protection.

Corresponding author:

John Ojal

PO Box 230- 80108

Kilifi, Kenya.

Tel +254 728 095 710

E-mail: jojal@kemri-wellcome.org

Abstract

Background: Prior studies have demonstrated hyporesponsiveness to pneumococcal conjugate vaccines (PCVs) when administered in the presence of homologous carriage. This may be substantially more important in Africa where carriage prevalence is high. Deriving a correlate of protection (CoP) for carriage is important in guiding the future use of extended PCVs as population control of pneumococcal disease by vaccination is now focused principally on its indirect effect. We therefore explored the complex relationship between existing carriage and vaccine responsiveness, and between serum IgG levels and risk of acquisition.

Methods: We undertook secondary analyses of data from two previously published clinical trials of the safety and immunogenicity of PCV in Kenya. We compared responses to vaccination between serotype-specific carriers and non-carriers at vaccination. We assessed the risk of carriage acquisition in relation to PCV-induced serum IgG levels using either a step- or continuous-risk function.

Results: For newborns, the immune response among carriers was 51-82% lower than that among non-carriers, depending on serotype. Among toddlers, for serotypes 6B, 14 and 19F the post-vaccination response among carriers was lower by between 29 -70%. The estimated CoP against acquisition ranged from 0.26 to 1.93 mg/mL across serotypes, however, these thresholds

could not be distinguished statistically from a model with constant probability of carriage independent of assay value.

Conclusion: We have confirmed hyporesponsiveness in an equatorial African setting in both infants and toddlers. Population responses to vaccination are likely to improve with time as carriage prevalence of vaccine serotypes is reduced. We have not found clear correlates of protection against carriage acquisition among toddlers in this population. Assessing the potential of new vaccines through the use of CoP against carriage is still difficult as there are no clear-cut serotype specific correlates.

Introduction

The first pneumococcal conjugate vaccine (PCV), which contained seven serotypes, reduced the incidence of pneumococcal disease and the prevalence of nasopharyngeal carriage in both vaccinated and unvaccinated children as well as adults when introduced into routine infant immunisation programme in the USA in 2000 [1]. The indirect protective effect of PCV is caused by a vaccine-induced reduction in the risk of acquiring colonisation by vaccine serotypes (VTs), which leads to a reduction in onward transmission from young children.

Recently, data have emerged that highlight the complexity of interactions between pneumococci, the human immune system and the nasopharynx. Infants carrying serotypes 6B, 19F or 23F at the time of PCV immunisation have reduced primary IgG responses to those serotypes [2,3] and this effect persists through to post-booster responses [4]. Rodenburg and colleagues showed that, at 24 months of age, children's responses to PCV against these three serotypes were reduced if they had carried them at any point in the 2 years prior to vaccination [5].

PCV responses in African children are generally thought to be higher than those seen in developed country settings [6–9]. For instance, the serotype-specific geometric mean foldrise between the time of the first dose and one month after the third dose of PCV were lower in USA [7] and Finland [9] compared to South Africa [6] and The Gambia [8]. Nonetheless, in parts of

Africa like The Gambia [10] and Kenya [11,12], carriage rates from very early in life are extremely high. Given high responses to PCV it is possible that hyporesponsiveness does not occur, or is immunologically irrelevant, in equatorial Africa.

The immunological mechanism that mediates vaccine-induced protection against colonisation at the mucosal level, or against disease, is not known. While circulating IgG may have a role in preventing colonisation, as demonstrated in a mouse model in which antibody blocked colonisation through agglutination [13], local B cells producing IgG and/or IgA in the nasopharynx may also be relevant and a role for T cells has also been suggested [14,15]. Nonetheless, to facilitate the licencing of new formulations of PCV, a single aggregate serological correlate of protection against invasive pneumococcal disease (IPD), has been derived based on circulating IgG [16,17]. However, a recent analysis that suggested correlates of protection (CoP) for IPD vary widely by serotype [18] has questioned the biological relevance of a single aggregate CoP common to all serotypes. It is likely that, as with IPD, the CoP against carriage also vary by serotype.

Numerous assumptions were made during the development of the common serological CoP and there is equipoise in the scientific community about the relevance of the CoP to carriage and mucosal disease [19]. For some serotypes, greater concentrations of serum IgG were likely to be required to protect at mucosal surfaces (e.g. in the nasopharynx) than in blood [20]. Subsequent analysis of vaccine-induced antibody and the prevention of carriage reinforced the notion that if circulating IgG is indeed a relevant

correlate for carriage, remarkably high concentrations are required to reduce carriage acquisition [21]. Deriving CoP for carriage would guide the future use of extended PCVs, as population control of pneumococcal disease by vaccination is now focused principally on its indirect effect mediated through carriage [22].

We therefore set out to explore both the relationship between existing carriage and vaccine responsiveness and between serum IgG levels and risk of acquisition by undertaking new analyses of two existing field studies of PCV in Kenya, with the following questions: (i) Does hyporesponsiveness occur in high carriage settings like Kenya? (ii) If so, can we detect this for serotypes other than the most common (e.g. 6B, 19F and 23F)? (iii) Is it possible to derive a serological correlate of protection against carriage acquisition using vaccine-induced IgG responses detected within randomized controlled trials of PCV in Kenya?

Methods

Data

Data from two previously published clinical trials of the safety and immunogenicity of PCV conducted in Kenya [14, 15] were further analysed in the current study. The first study (“Newborn study”) recruited 300 newborns that were randomized to receive 7-valent PCV (PCV7) in one of two vaccine schedules; at 0-10-14 weeks or at 6-10-14 weeks. The subjects received a PCV7 or 23-valent Pneumococcal Polysaccharide Vaccine (PPV23) booster dose of at 36 weeks. Serological measurements were made at 0, 6, 10, 14,

18, 36 and 37 weeks and nasopharyngeal carriage ascertained at 18 and 36 weeks. The objectives of this study were to examine the effect of a newborn vaccination schedule with PCV7 on the development of antibody and carriage prevalence. In the current analysis we used the carriage data at the time of the booster (week 36) and the serological measurements at week 36 and week 37.

The second study (“Toddler study”) recruited 600 children aged 1-4 years to examine the effect of 0, 1 or 2 doses of a 10-valent PCV (PCV10), on capsular antibody concentrations and nasopharyngeal carriage. Children were given PCV10 in three different schedules: Group A received PCV10 at day 0 and day 60; Group B received PCV10 at day 0 and day 180. Diphtheria-tetanus-pertussis (DTaP) was given as a control vaccine to group A at day 180 and to Group B at day 60. A third group, which is not considered in this analysis, received Hepatitis A virus (HAV) at day 0 and day 180 and DTaP at day 60. Antibody measurements were made at days 0, 30, 90 and 210 and nasopharyngeal carriage assessed at days 0, 30, 60, 90 and 180. Details of the study have been published elsewhere [23]. In the current analysis we used carriage data from vaccinees in Groups A and B at day 0, 60 and 180 (vaccination time points), and serological measurements 30 days post vaccination i.e. at 30, 90 and 210 days, respectively.

Analysis

For the newborn study, we calculated the fold-rise in serotype-specific geometric mean concentrations (GMC) between weeks 36 and 37, separately,

for carriers and non-carriers for each of the seven serotypes in PCV7. The differences between the two groups (homologous carriers vs. non-carriers) were quantified as ratios of the GMC fold-rises. These ratios were derived from log-linear regression models of the booster response taking account the vaccine schedule group (6-10-14 vs. 0-10-14), type of booster given (PCV7 vs. PPV23) and the baseline log-concentration of IgG, at 36 weeks. Baseline IgG concentrations is adjusted for since individuals with lower concentrations have more room for greater fold-rise than individuals who already have high concentration at baseline.

For the toddler study, we pooled paired carriage data and 30-day serological responses for each of the time points of PCV10 vaccination (0, 60 and 180 days). We calculated serotype-specific fold-rises in IgG concentration 30 days later (at 30, 90 and 210 days). There were no blood samples at time 60 and 180 by design therefore we used the IgG at time 30 to adjust for responses to vaccines given at 60 and 180 days. We would expect antibody concentrations to decay from day 30 to day 60 (and from day 30 to day 180) at the same rate for subjects in both Group A and Group B; therefore, the ranks in IgG baseline between time 30 days and the time of vaccination are likely to be highly correlated, provided that natural boosting is also distributed equally in both groups. To assess the impact of carriage at the time of vaccination, GMC fold-rise ratios between homologous carriers vs. non-carriers were estimated from log-linear serotype-specific regression models of the individual level fold-rise on the carriage status, taking account of the vaccine group (Group A and B), age group (12-23, 24-35, 36-47 and 48-59 months), season (month of sample

collection) and pre-vaccine (day 0 or 30) log IgG. We used Generalized Estimating Equations (GEE) to account for the correlations between the repeated measures within an individual. Data for serotypes 6B, 9V, 14, 19F and 23F were selected for the analysis since they were the most frequently carried of the 10 vaccine-type serotypes. As a supplementary analysis, we also calculated the post-vaccination GMC by pre-vaccination carriage status for both the newborn and toddler studies.

In order to derive the serotype-specific antibody threshold for vaccine efficacy against acquisition, we restricted our analysis to data from the toddler study and, in particular, to toddlers who were non-carriers at day zero. We compared carriage status at day-30 against vaccine-induced IgG concentration measured at day 30. We fitted to these two variables a model that incorporates a threshold parameter that is estimated through a profile likelihood [24], the a:b model. The model is a step-shaped function where the step corresponds to the antibody threshold. Thus, in addition to the threshold parameter, the model also contains two parameters for constant but different acquisition probabilities below and above the threshold. A test for the presence of a threshold was achieved by comparing the a:b model to a model with constant probability of acquisition independent of assay value, using a likelihood ratio test. Confidence intervals around the threshold estimates were constructed through bootstrapping.

The a:b model does not allow for adjustment of covariates, therefore, we also modelled the risk of serotype-specific acquisition as a continuous function of

log-IgG concentration in a Cox proportional hazards model that accounted for age group, carriage of a heterologous serotype at the point of vaccination, log IgG on the day of vaccination and season. Non-linear relationship between the acquisition incidence and log-IgG concentration was allowed through restricted cubic splines. Having no colonization by any serotype at day 0 predisposes one to considerably higher risk of colonization by an index serotype relative to someone colonised by a different serotype to the index at day 0, due to serotype competition [25,26]. This was the rationale for including carriage of a heterologous serotype at the point of vaccination in the model.

Results

In the newborn study, 235 pairs of 36- and 37-week samples were analysed. In these subjects the prevalence of carriage of PCV7 serotypes at 36 weeks ranged from 0.9% for serotype 23F to 12.8% for serotype 19F. Compared to non-carriers, the GMC fold-rise between week 36 and week 37 among carriers was substantially lower by a factor of 51-82% (Table 1). The point estimates of the GMC at post-booster (37 weeks) were higher among non-carriers at the point of vaccination, except of serotype 18C (Supplementary table S1).

In the toddler study, between 460-480 samples were analysed depending on serotype. The carriage prevalence at the time of vaccination ranged from 2.1% for serotype 9V to 8.0% for serotype 19F (Table 2). For serotypes 6B, 14 and 19F the GMC fold-rise post vaccination among carriers was lower by between 29 -70%. For serotype 9V and 23F the GMC fold-rise were 53% and

1% higher among carriers (Table 2). Except for serotype 9V the point estimates of the GMC post-vaccination were higher among non-carriers at the time of vaccination (Supplementary table S2).

We computed the serological threshold for vaccine efficacy against acquisition among serotype-specific non-carriers at the first vaccination time-point (day 0) by using their titres and carriage status 30 days later in the toddler study. The estimated thresholds ranged from 0.26 to 1.93 mg/mL across serotypes, however, a test for the presence of a threshold at these points suggested no significant difference from a model with constant probability of acquisition independent of assay value (Table 3).

We analysed carriage acquisition as a continuous function of log IgG. There was no convincing monotonically decreasing rate of carriage with increasing log IgG for each of the five serotypes (Figure 1). In a situation where a higher level IgG had strong negative impact on carriage, the prevalence ratios below the average (mean/median) log IgG would be above 1 and the prevalence ratios above the average log IgG would be below 1, in the plots.

Discussion

While inferior quantitative antibody responses to the colonising serotypes have been reported amongst children vaccinated with PCV in Philippines [2], Israel [3] and South Africa [27], none have studied this phenomenon in high carriage settings such as Equatorial Africa. Using data from two clinical trials

in Kenya, we have confirmed hyporesponsiveness in equatorial Africa in both infants and toddlers, and for the first time described it in serotype 14.

The reduced immune responses to PCV administered to an individual with prevailing carriage may reduce the vaccine's efficacy. The clinical implication of this is an increased susceptibility to acquisition of homologous pneumococcal serotypes, particularly when the reduction in immune response results in lower than sufficient protection against carriage. Several strategies can be useful in high carriage settings to counter the effect of hyporesponsiveness. The use of a catch-up campaign at the time of PCV introduction can speed-up the reduction in vaccine-type carriage thus improving the immune responses in cohorts vaccinated in the subsequent period of reduced carriage. Using a booster dose in the second year of life can also be used to overcome hyporesponsiveness [3]. However, the cost-effectiveness of such strategies needs to be evaluated to provide further evidence for or against their use.

We assessed the association between IgG concentration and the incidence of carriage in two ways; using a step function, the a:b model, which explicitly models a threshold and using a model with carriage incidence as a continuous function of IgG concentration, which does not explicitly model a threshold. The second approach allowed us to study the relation while accounting for potential confounding factors. The result from each of the approaches is mutually important and complementary in interpreting results from the alternative approach.

The CoP for carriage were generally higher than the recently derived serotype-specific CoP for IPD with the exception of serotype 14 (0.26 mg/ml for carriage acquisition vs. 0.46 mg/ml for IPD) [28]. It is expected that the CoP for carriage should be substantially higher than that for IPD; therefore, the result for serotype 14 is surprising. The evidence for the CoP for carriage being lower is, however, limited given the wide 95% confidence intervals of the CoP estimate of this serotype (Table 3) and the function of IgG that does not show drastic change around the estimated CoP (Figure 1).

For serotype 9V, all the carriers were above the estimated CoP against acquisition. This scenario reflects one of the potential problems with the a:b model, that in the estimation process the incidence below a candidate threshold is not restricted to be higher than that above it. This requirement is, however, imposed post-estimation in the test for the existence of a threshold at the estimated value [24], such that the test statistic always yields a non-significant result in such cases. Whether circulating IgG is the correct correlate of protection also needs to be considered. The exact mechanism by which pneumococci are prevented from colonising the nasopharynx is still unclear.

The licensing of future PCVs will likely take into account the potential impact on carriage [29]. Therefore, defining the CoP for carriage would provide a way of assessing the non-inferiority of new vaccines as has been the case for CoP for IPD [16,17]. However, until a better understanding of existing CoP for IPD

exists this may be complex. For example, there is limited information to sufficiently explain why IPD correlates for some serotypes are high and others low. Consequently, predicting whether the CoP for a novel serotype will be higher or lower, and by what factor, than available CoP for other serotypes is difficult. New PCVs might incorporate serotypes that are carried relatively infrequently further complicating the use of CoP for carriage. Only one previous study that was conducted in the United Kingdom has reported on PCV CoP for carriage where a clear threshold against carriage for a single serotype, serotype 14, was identified [20]. A second study in the Navajo Nation and White Mountain Apache tribal lands, in USA, did not find identifiable IgG threshold level that was associated with prevention of carriage acquisition for all the eight serotypes studied [30].

A limitation of the newborn study is that the period between booster dose and the assessment of its effect was one week. It generally takes about 4 weeks for a full immune response following vaccination. Therefore, what we show is that the impact of pre-existing carriage on immune response is notable as early as one week. It is possible that after 4 weeks the final concentrations between carriers and non-carriers are similar. If that is the case then the effect of pre-existing carriage is in delaying immune response. From the toddler study, in which there was sufficient time-lapse between vaccination and assessment of response, the final concentrations were still different between carriers and non-carriers. It is unlikely that the case is different for newborns, because the mechanism causing hypo-responsiveness should be similar between the two age groups.

In conclusion, we have confirmed hyporesponsiveness in an equatorial African setting in both infants and toddlers. Pneumococcal conjugate vaccines have been introduced in many African countries where carriage is generally high. Hyporesponsiveness might reduce the vaccine's effectiveness in the early years of introduction when the prevalence of vaccine serotypes is still high. If so, the speed with which vaccine-type carriage prevalence is reduced will determine how fast improved responses are realised in later years after vaccine introduction, when cohorts of children with reduced vaccine-type carriage rates replace the cohorts in high prevalence period. We did not identify clear correlates of protection against carriage acquisition among toddlers in this population. Given the limited information from the few studies that have reported on correlate of protection against carriage, assessing the potential of new vaccines through the use of correlate of protection against carriage remains difficult, as there are no clear-cut serotype-specific correlates.

Funding: The work was supported by the Wellcome Trust fellowships [092767 to JO, 098532 to JAGS].

Conflict of interest: LLH has received institutional research grants from Pfizer and GlaxoSmithKline. The rest of the authors do not have a commercial or other association that might pose a conflict of interest.

Ethics statement: the Kenya Medical Research Institute (KEMRI) Ethical review committee (Protocol number, SCC 2273) approved the study. This paper is published with the permission of the Director, Kenya Medical Research Institute.

References

- [1] Myint TTH, Madhava H, Balmer P, Christopoulou D, Attal S, Menegas D, et al. The impact of 7-valent pneumococcal conjugate vaccine on invasive pneumococcal disease: A literature review. *Adv Ther* 2013;30:127–51. doi:10.1007/s12325-013-0007-6.
- [2] Väkeväinen M, Soininen A, Lucero M, Nohynek H, Auranen K, Mäkelä PH, et al. Serotype-specific hyporesponsiveness to pneumococcal conjugate vaccine in infants carrying pneumococcus at the time of vaccination. *J Pediatr* 2010;157:778–83.e1. doi:10.1016/j.jpeds.2010.04.071.
- [3] Dagan R, Givon-Lavi N, Greenberg D, Fritzell B, Siegrist C-A. Nasopharyngeal carriage of *Streptococcus pneumoniae* shortly before vaccination with a pneumococcal conjugate vaccine causes serotype-specific hyporesponsiveness in early infancy. *J Infect Dis* 2010;201:1570–9. doi:10.1086/652006.
- [4] Licciardi P V, Russell FM, Balloch A, Burton RL, Nahm MH, Gilbert G, et al. Impaired serotype-specific immune function following pneumococcal vaccination in infants with prior carriage. *Vaccine* 2014;32:2321–7. doi:10.1016/j.vaccine.2014.02.064.
- [5] Rodenburg GD, van Gils EJM, Veenhoven RH, Bogaert D, van den Dobbelsteen GPJM, Berbers GAM, et al. Lower immunoglobulin G antibody responses to pneumococcal conjugate vaccination at the age of 2 years after previous nasopharyngeal carriage of *Streptococcus pneumoniae*. *J Pediatr* 2011;159:965–70.e1. doi:10.1016/j.jpeds.2011.06.011.
- [6] Mbelle N, Huebner RE, Wasas a D, Kimura a, Chang I, Klugman KP. Immunogenicity and impact on nasopharyngeal carriage of a nonavalent pneumococcal conjugate vaccine. *J Infect Dis* 1999;180:1171–6. doi:10.1086/315009.
- [7] O'Brien K, Moulton L, Reid R, Weatherholtz R, Oski J, Brown L, et al. Efficacy, safety and immunogenicity of heptavalent pneumococcal conjugate vaccine in children. Northern California Kaiser Permanente Vaccine Study Center Group. *Pediatr Infect Dis J* 2000;19:187–95.
- [8] Obaro SK, Adegbola R a, Chang I, Banya W a, Jaffar S, Mcadam KW, et al. Safety and immunogenicity of a nonavalent pneumococcal vaccine conjugated to CRM197 administered simultaneously but in a separate syringe with diphtheria, tetanus and pertussis vaccines in Gambian infants. *Pediatr Infect Dis J* 2000;19:463–9.
- [9] Nurkka a, Ahman H, Korkeila M, Jääntti V, Käyhty H, Eskola J. Serum and salivary anti-capsular antibodies in infants and children immunized with the heptavalent pneumococcal conjugate vaccine. *Pediatr Infect Dis J* 2001;20:25–33. doi:10.1097/00006454-200101000-00006.
- [10] Hill PC, Cheung YB, Akisanya A, Sankareh K, Lahai G, Greenwood BM, et al. Nasopharyngeal carriage of *Streptococcus pneumoniae* in Gambian infants: a longitudinal study. *Clin Infect Dis* 2008;46:807–14.

- doi:10.1086/528688.
- [11] Tigoi CC, Gatakaa H, Karani A, Mugo D, Kungu S, Wanjiru E, et al. Rates of acquisition of pneumococcal colonization and transmission probabilities, by serotype, among newborn infants in Kilifi District, Kenya. *Clin Infect Dis* 2012;55:180–8. doi:10.1093/cid/cis371.
- [12] Hammitt LL, Akech DO, Morpeth SC, Karani A, Kihuha N, Nyongesa S, et al. Population effect of 10-valent pneumococcal conjugate vaccine on nasopharyngeal carriage of *Streptococcus pneumoniae* and non-typeable *Haemophilus influenzae* in Kilifi, Kenya: findings from cross-sectional carriage studies. *Lancet Glob Heal* 2014:8–10. doi:10.1016/S2214-109X(14)70224-4.
- [13] Zangari T, Wang Y, Weiser JN. *Streptococcus pneumoniae* Transmission Is Blocked by Type-Specific Immunity in an Infant Mouse Model. *MBio* 2017;8:e00188-17. doi:10.1128/mBio.00188-17.
- [14] Pido-Lopez J, Kwok WW, Mitchell TJ, Heyderman RS, Williams NA. Acquisition of pneumococci specific effector and regulatory Cd4 + T cells localising within human upper respiratory-tract mucosal lymphoid tissue. *PLoS Pathog* 2011;7. doi:10.1371/journal.ppat.1002396.
- [15] Lu Y-J, Gross J, Bogaert D, Finn A, Bagrade L, Zhang Q, et al. Interleukin-17A mediates acquired immunity to pneumococcal colonization. *PLoS Pathog* 2008;4:e1000159. doi:10.1371/journal.ppat.1000159.
- [16] Jódar L, Butler J, Carlone G, Dagan R, Goldblatt D, Käyhty H, et al. Serological criteria for evaluation and licensure of new pneumococcal conjugate vaccine formulations for use in infants. *Vaccine* 2003;21:3265–72. doi:10.1016/S0264-410X(03)00230-5.
- [17] Siber GR, Chang I, Baker S, Fernsten P, O'Brien KL, Santosham M, et al. Estimating the protective concentration of anti-pneumococcal capsular polysaccharide antibodies. *Vaccine* 2007;25:3816–26. doi:10.1016/j.vaccine.2007.01.119.
- [18] Andrews NJ, Waight PA, Burbidge P, Pearce E, Roalfe L, Zancolli M, et al. Serotype-specific effectiveness and correlates of protection for the 13-valent pneumococcal conjugate vaccine: A postlicensure indirect cohort study. *Lancet Infect Dis* 2014;14:839–46. doi:10.1016/S1473-3099(14)70822-9.
- [19] Principi N, Esposito S. Serological criteria and carriage measurement for evaluation of new pneumococcal vaccines. *Hum Vaccines Immunother* 2015;11:1494–500. doi:10.1080/21645515.2015.1033600.
- [20] Goldblatt D, Hussain M, Andrews N, Ashton L, Virta C, Melegaro A, et al. Antibody responses to nasopharyngeal carriage of *Streptococcus pneumoniae* in adults: a longitudinal household study. *J Infect Dis* 2005;192:387–93. doi:10.1086/431524.
- [21] Dagan R, Juergens C, Trammel J, Patterson S, Greenberg D, Givon-Lavi N, et al. Modeling pneumococcal nasopharyngeal acquisition as a function of anticapsular serum antibody concentrations after pneumococcal conjugate vaccine administration. *Vaccine*

- 2016;34:4313–20. doi:10.1016/j.vaccine.2016.06.075.
- [22] Flasche S, Van Hoek AJ, Goldblatt D, Edmunds WJ, O'Brien KL, Scott JAG, et al. The Potential for Reducing the Number of Pneumococcal Conjugate Vaccine Doses While Sustaining Herd Immunity in High-Income Countries. *PLoS Med* 2015;12:1–5. doi:10.1371/journal.pmed.1001839.
- [23] Hammitt LL, Ojal J, Bashraheil M, Morpeth SC, Karani A, Habib A, et al. Immunogenicity, Impact on Carriage and Reactogenicity of 10-Valent Pneumococcal Non-Typeable Haemophilus influenzae Protein D Conjugate Vaccine in Kenyan Children Aged 1-4 Years: A Randomized Controlled Trial. *PLoS One* 2014;9:e85459. doi:10.1371/journal.pone.0085459.
- [24] Chen X, Bailleux F, Desai K, Qin L, Dunning AJ. A threshold method for immunological correlates of protection. *BMC Med Res Methodol* 2013;13:29. doi:10.1186/1471-2288-13-29.
- [25] Lipsitch M, Dykes JK, Johnson SE, Ades EW, King J, Briles DE, et al. Competition among Streptococcus pneumoniae for intranasal colonization in a mouse model. *Vaccine* 2000;18:2895–901.
- [26] Auranen K, Mehtälä J, Tanskanen A, S Kaltoft M. Between-strain competition in acquisition and clearance of pneumococcal carriage--epidemiologic evidence from a longitudinal study of day-care children. *Am J Epidemiol* 2010;171:169–76. doi:10.1093/aje/kwp351.
- [27] Madhi SA, Violari A, Klugman KP, Lin G, McIntyre JA, Gottberg A von, et al. Inferior quantitative and qualitative immune responses to pneumococcal conjugate vaccine in infants with nasopharyngeal colonization by Streptococcus pneumoniae during the primary series of immunization. *Vaccine* 2011;29:6994–7001. doi:10.1016/j.biotechadv.2011.08.021.Secreted.
- [28] Andrews NJ, Waight PA, Burbidge P, Pearce E, Roalfe L, Zancolli M, et al. Serotype-specific effectiveness and correlates of protection for the 13-valent pneumococcal conjugate vaccine: a postlicensure indirect cohort study. *Lancet Infect Dis* 2014;14:839–46. doi:10.1016/S1473-3099(14)70822-9.
- [29] Goldblatt D, Ramakrishnan M, O'Brien K. Using the impact of pneumococcal vaccines on nasopharyngeal carriage to aid licensing and vaccine implementation; A Pneumocarr meeting report March 27-28, 2012, Geneva. *Vaccine* 2013;32:146–52. doi:10.1016/j.vaccine.2013.06.040.
- [30] Grant L, Burbidge P, Goldblatt D, Donaldson C, Weatherholtz R, Reid R, et al. Levels of Anticapsular IgG and Protection Against Acquisition of Pneumococcus. *Int. Symposium Pneumococci Pneumococcal Dis., Glasgow, Scotland.:* 2016.

Table 1: Newborn study. Geometric mean fold rise between 36 and 37 weeks (with 95% confidence limits) stratified by carrier status, as well as the difference in the response between carriers and non-carriers expressed as a ratio. These ratios, and associated *p* values were derived from log-linear regression models of the booster response taking account of the vaccine group (EPI vs. newborn), the type of booster given (*Pneumococcal polysaccharide vaccine* vs. *Pneumococcal conjugate vaccine*) and log IgG in week 36.

Serotype	Carriers at 36 weeks		Non-carriers at 36 weeks		Ratio (95% CIs) for carrier/non-carrier	P-value
	n	GM fold-rise 37/36 Weeks (95% CI)	n	GM fold-rise 37/36 Weeks (95% CI)		
4	0	-	235	4.92 (4.36 – 5.55)	-	-
6B	6	2.85 (0.69 – 11.68)	229	13.52 (11.52 – 15.88)	0.18 (0.07 – 0.46)	<0.001
9V	4	1.62 (0.64 – 4.11)	231	5.32 (4.72 – 6.00)	0.31 (0.14 – 0.69)	0.005
14	10	1.29 (0.86 – 1.92)	225	2.79 (2.47 – 3.15)	0.49 (0.30 – 0.80)	0.004
18C	3	1.25 (0.87 – 1.79)	232	7.74 (6.87 – 8.73)	0.15 (0.05 – 0.40)	<0.001
19F	30	1.91 (1.34 – 2.73)	204	7.19 (6.11 – 8.45)	0.32 (0.21 – 0.48)	<0.001
23F	2	3.59 (0.02 – 663.49)	231	10.33 (8.80 – 12.14)	0.25 (0.06 – 1.09)	0.064

n: number of individuals

Table 2: Toddler study. Geometric mean fold-rise between day 0 to 30 or day 30 to 90/210 stratified by carrier status at the time of vaccination (day 0, 60 or 180), as well as the difference in the response between carriers and non-carriers expressed as a ratio. The ratios and associated *p*-values were derived from log-linear serotype specific regression models, using GEE, of the individual level fold-rise on the carriage status, taking account of the vaccine group (Group A and B), age group (12-23, 24-35, 36-47 and 48-59 months), season (month of swab) and pre-vaccine (day 0 or 30) log IgG.

Serotype	Carriers at point of vaccination		Non-carriers at point of vaccination		Ratio (95% CIs) for carrier/non-carrier	P-value
	n ^a	GM fold-rise (95% CI)	n ^a	GM fold-rise (95% CI)		
6B	23	1.65 (1.22 – 2.24)	457	2.35 (2.14 – 2.59)	0.70 (0.51 – 0.97)	0.034
9V	10	1.88 (0.98 – 3.61)	466	3.06 (2.65 – 3.53)	1.53 ^b (0.89 – 2.65)	0.119
14	15	3.02 (1.99 – 4.58)	445	5.32 (4.65 – 6.10)	0.71 (0.50 – 1.02)	0.067
19F	38	2.12 (1.57 – 2.87)	439	7.61 (6.50 – 8.90)	0.30 (0.19 – 0.46)	<0.001
23F	22	3.39 (1.35 – 8.47)	455	4.28 (3.66 – 5.00)	1.01 (0.63 – 1.63)	0.955

^aThere are two repeated measures for almost all participants. These numbers reflect the number of samples rather than individuals.

^bThe reason why the adjusted ratio is above 1 (instead of approx. 1.88/3.06=0.61, which is the unadjusted ratio) is because one of the factors adjusted for (pre-vaccine log IgG) was unevenly distributed among carriers vs. non-carriers; the GMC of pre-vaccine log IgG among carriers was significantly higher at 1.61 compared to 0.49 in non-carriers. Similar case for 23F.

Table 3: Toddler study. The serotype-specific serological thresholds for vaccine efficacy against acquisition for five most commonly carried serotypes at day 0. The thresholds are computed using a step-shaped function where the step corresponds to the threshold with different infection probabilities below and above the threshold. The threshold with the highest profile likelihood is chosen as the parameters estimate. Confidence intervals are constructed by bootstrapping.

Serotype	Threshold (95% CI)	Carriage prevalence Ratio ^a (95% CI)	Test for presence of a threshold ^b	Goodness of fit p-value ^c
6B	0.48 (0.07 - 2.68)	0.21 (0.04-0.72)	0.079	0.048
9V ^d	1.86 (1.86 - 22.67)	--	>0.999	0.219
14	0.26 (0.16 - 14.34)	0.26 (0.04-0.87)	0.542	0.851
19F	1.66 (0.85 - 6.60)	0.10 (0.00-0.60)	0.171	0.314
23F ^e	1.93 (0.09 - 1.94)	0.00 (0.00-0.00)	0.430	0.625

^a Carriage prevalence ratio is the carriage risk above the threshold divided by carriage risk below threshold, the confidence interval is obtained by bootstrapping

^b likelihood ratios test for the presence of a threshold. Achieved by comparing the a:b model to a model with constant probability of infection independent of assay value. Values above 0.05 indicate no sufficient evidence of a difference in the two models at % level of significance.

^cThis is the Hosmer and Lemeshow goodness of fit p-value testing the null hypothesis that there is no difference between observed and model predicted values. The test assesses whether the step function represented by the a:b model is an appropriate representation of infection or whether another relationship such as a gradual one between titre and infection might be more likely than a stepped relationship. All the p-values, except that for serotype 6B, which is borderline, are above 0.05 indicating insufficient evidence against the null hypothesis at the 5% level of significance.

^dThere were no carriers of serotype 9V below the threshold of 1.86 mcg/ml hence the risk ratio was undefined

^eThere were no carriers of serotype 23F above the threshold of 1.93 mcg/ml hence the risk ratio was zero

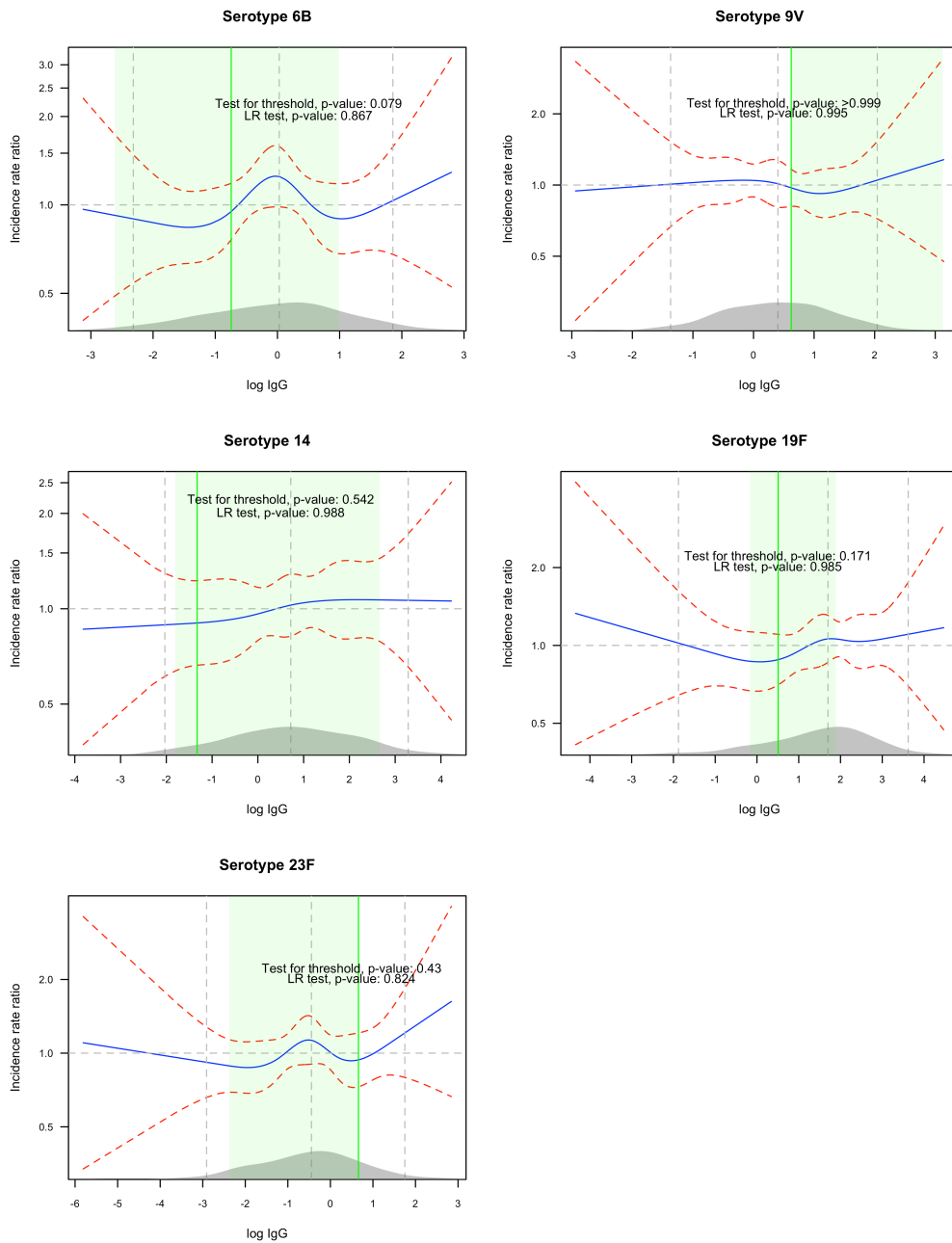

Figure 1: The incidence rate ratio (blue solid line) as a function of log IgG titre (x-axis) for each serotype labelled above the graph. The ratios are between the values of log IgG on the x-axis relative to someone with the average log IgG. For instance, for serotype 6B, the rate ratio between individuals with log IgG of -3 relative to individuals with the mean log IgG is slightly below 1 (95% CI: ~ 0.5 to 2). The red dashed lines are the 95%CI bounds of the rate ratio. The three vertical (grey) lines mark the 2.5th, 50th and 97.5th percentiles of the distribution of log IgG whose density is shown in grey on the x-axis. The green line shows the CoP obtained by the a:b model while the light green shade around it shows the region covered by the bootstrapped 95%CI of that CoP. The likelihood ratio (LR) test p-value for the significance of log IgG in predicting carriage acquisition and the test for the presence of a threshold estimated by the a:b model is indicated in the plot.

Appendix

Table S1: Newborn study. Geometric mean post-vaccination (at 37 weeks) stratified by carrier status, as well as the difference in the response between carriers and non-carriers expressed as a ratio. These ratios, and associated *p* values were derived from log-linear regression models of the booster response taking account of the vaccine group (EPI vs. newborn), the type of booster given (*Pneumococcal polysaccharide vaccine vs. Pneumococcal conjugate vaccine*) and log IgG in week 36.

Serotype	Carriers at 36 weeks		Non-carriers at 36 weeks		Ratio ^a (95% CIs) for carrier/non-carrier	P-value
	n	GM at 37 weeks (95% CI)	n	GM at 37 weeks (95% CI)		
4	0	-	236	3.69 (3.21 – 4.24)	-	-
6B	6	0.71 (0.06 – 8.01)	230	10.13 (8.44 – 12.16)	0.18 (0.07 – 0.46)	<0.001
9V	4	1.28 (0.06 – 26.16)	232	4.04 (3.48 – 4.69)	0.31 (0.14 – 0.69)	0.005
14	10	4.23 (1.18 – 15.17)	226	7.61 (6.45 – 8.98)	0.49 (0.30 – 0.80)	0.004
18C	3	14.98 (2.52 – 89.07)	233	3.49 (2.98 – 4.09)	0.15 (0.05 – 0.40)	<0.001
19F	30	2.25 (1.47 – 3.43)	206	6.45 (5.50 – 7.57)	0.32 (0.21 – 0.48)	<0.001
23F	2	2.58 (0.61 – 10.95)	232	5.49 (4.61 – 6.52)	0.25 (0.06 – 1.09)	0.064

n: number of individuals

^a The ratio comparing carriers vs. non-carriers obtained by regressing the log-concentration post-vaccination against carriage status at the point of vaccination (adjusting for pre-vaccination log-concentration, among other variables) is similar to that obtained when the response variable is instead the log of fold-rise (post-vaccination IgG divided by pre-vaccination IgG) and adjustment is also made for pre-vaccination log-IgG (Table 1). This is because only the coefficient of the pre-vaccination log-IgG will be altered across the two models; the coefficients of the rest of the predictors remain equal across the models.

Table S2: Toddler study. Geometric mean post-vaccination (day 30, 90/210) stratified by carrier status at the time of vaccination (day 0, 60 or 180), as well as the difference in the response between carriers and non-carriers expressed as a ratio. The ratios and associated *p*-values were derived from log-linear serotype specific regression models, using GEE, of the individual level post-vaccination log-IgG level on the carriage status, taking account of the vaccine group (Group A and B), age group (12-23, 24-35, 36-47 and 48-59 months), season (month of swab) and pre-vaccine (day 0 or 30) log IgG.

Serotype	Carriers at point of vaccination		Non-carriers at point of vaccination		Ratio ^b (95% CIs) for carrier/non-carrier	P-value
	n ^a	GM post-vaccination (95% CI)	n ^a	GM post-vaccination (95% CI)		
6B	23	1.03 (0.66 – 1.62)	457	1.23 (1.12 – 1.36)	0.70 (0.51 – 0.97)	0.034
9V	10	3.04 (1.36 – 6.77)	468	1.51 (1.40 – 1.64)	1.53 (0.89 – 2.65)	0.119
14	15	2.24 (1.14 – 4.42)	449	3.18 (2.79 – 3.63)	0.71 (0.50 – 1.02)	0.067
19F	39	0.58 (0.32 – 1.06)	442	7.18 (6.21 – 8.30)	0.30 (0.19 – 0.46)	<0.001
23F	22	0.74 (0.38 – 1.41)	457	0.80 (0.72 – 0.89)	1.01 (0.63 – 1.63)	0.955

^aThere are two repeated measures for almost all participants. These numbers reflect the number of samples rather than individuals.

^bThe ratio comparing carriers vs. non-carriers obtained by regressing the log-concentration post-vaccination against carriage status at the point of vaccination (adjusting for pre-vaccination log-concentration, among other variables) is similar to that obtained when the response variable is instead the log of fold-rise (post-vaccination IgG divided by pre-vaccination IgG) (Table 2). This is because only the coefficient of the pre-vaccination log-IgG will be altered across the two models; the coefficients of the rest of the predictors remain equal across the models.

Chapter 4: Research paper 3

Title: Effect of maternally-derived anti-protein and anti-capsular IgG antibodies on the rate of acquisition of nasopharyngeal carriage of pneumococcus in newborns

Author(s): John Ojal, David Goldblatt, Caroline Tigoi, J. Anthony G. Scott

Journal/Publisher: Clinical Infectious Diseases, doi.org/10.1093/cid/cix742

Type of publication: Original contribution

Stage of publication: Advance article

Academic peer-reviewed: Yes

Copyright: Open access

Candidate's role:

Prof. Anthony Scott designed the study. I proposed and implemented the statistical models to analyze data from this study and generated all the results presented in the manuscript. I wrote the first draft of the manuscript, reviewed and responded to all comments from co-authors as well as those from journal reviewers to generate the published manuscript.

Candidate's signature: 

Supervisor or senior author's signature to confirm Candidates role:

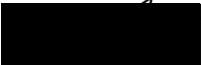

Effect of maternally-derived anti-protein and anti-capsular IgG antibodies on the rate of acquisition of nasopharyngeal carriage of pneumococcus in newborns

Short title: Maternal IgG and pneumococcal carriage

John Ojal^{1,2}, David Goldblatt³, Caroline Tigoi¹, J. Anthony G. Scott^{1,2}

1. KEMRI-Wellcome Trust Research Programme, Centre for Geographic Medicine-Coast, Kilifi, Kenya
2. Department of Infectious Disease Epidemiology, Faculty of Epidemiology and Population Health, London School of Hygiene and Tropical Medicine, London, United Kingdom.
3. Great Ormond Street Institute of Child Health, University College, London, United Kingdom.

Key words: antibodies; pneumococcus; nasopharyngeal carriage; Kenya;

Corresponding author:

John Ojal
P.O Box 230-80108
Kilifi, Kenya.
Tel: +254 728 095 710
E-mail: jojal@kemri-wellcome.org

Alternate corresponding author:

Prof. Anthony Scott
P.O Box 230-80108
Kilifi, Kenya.
Tel: +254 705 412 719
E-mail: ascott@ikilifi.org

Abstract

Background

In developing countries, introduction of pneumococcal conjugate vaccine has not eliminated circulation of vaccine serotypes. Vaccinating pregnant mothers to increase antibody concentrations in their newborn infants may reduce the acquisition of pneumococcal carriage and subsequent risk of disease. We explored the efficacy of passive immunity, attributable to anti-protein and anti-capsular pneumococcal antibodies, against acquisition of carriage.

Methods

We examined the rate of nasopharyngeal acquisition of pneumococci in the first 90 days of life associated with varying anti-capsular and anti-protein antibody concentrations in infant cord/maternal venous blood in Kilifi, Kenya. We used multivariable Cox proportional hazard models to estimate continuous functions relating acquisition of nasopharyngeal carriage to the concentration of maternally-derived antibody.

Results

Cord blood or maternal venous samples were collected from 976 mother-infant pairs. Pneumococci were acquired 561 times during 33,905 person-days of follow up. Increasing concentrations of anti-protein antibodies were associated with either a reduction (PhtD1, PspAFam2, Spr0096, StkP) or, paradoxically, an increase (CbpA, LytC, PcpA, PiaA, PspAFam1, RrgBT4) in acquisition rate. We observed a non-significant reduction in the incidence of homologous carriage acquisition with high concentrations of maternally-

derived anti-capsular antibodies to five serotypes (6A, 6B, 14, 19F and 23F).

Conclusion

The protective efficacy of several anti-protein antibodies supports the strategy of maternal vaccination to protect young infants from carriage and invasive disease. We were not able to demonstrate that passive anti-capsular antibodies were protective against carriage acquisition at naturally occurring concentrations though it remains possible they may do so at the higher concentrations elicited by vaccination.

Introduction

Among infants in low-income countries, pneumococcal carriage is acquired rapidly. In Kenya, in the pre-vaccination era, more than 80% of newborns acquired nasopharyngeal carriage by the age of 90 days [1]. The median time to colonization was 45 days in Thailand [2] while in India 54% of infants aged 2 months carried pneumococci [3]. Colonization is an essential step in the pathway to invasive pneumococcal disease (IPD) [4]. In a pre-vaccine surveillance exercise in Kilifi, Kenya, 15% of IPD episodes occurred in the first two months of life [5].

Pneumococcal Conjugate Vaccine (PCV) has been introduced in many low income countries in schedules where infants are first vaccinated at either 6 weeks or two months of age [6]. In addition to direct protection of the vaccinated infant, the vaccine provides herd protection to unvaccinated individuals by interrupting transmission [7]. However, in contrast to developed countries [8], herd protection has not eliminated the circulation of vaccine serotypes in low-income countries and evidence from Kenya [9] and The Gambia [10] suggests that the prevalence of vaccine serotypes remains relatively high several years after vaccine introduction.

This justifies the evaluation of maternal or newborn vaccination as strategies to protect young infants. Newborn vaccination with the 7-valent PCV was safe and immunogenic in Kenya and Papua New Guinea [11,12]. In a review of studies of maternal vaccination, no safety concerns were reported with the 23-valent pneumococcal polysaccharide vaccine (PPV-23) or in the only study of

maternal vaccination with a 9-valent PCV [13,14]. Vaccination increased the passive transfer of antibodies to newborns, more so with the PCV [13].

Protein and whole cell pneumococcal vaccines, currently in clinical development, are designed to protect recipients against all serotypes of pneumococcus [15] and could be used, potentially, to protect young infants through newborn or maternal vaccination.

The correlates of protection (CoP) against invasive pneumococcal disease (IPD) have been established [16]. Attempts to derive CoP for vaccine-induced protection against carriage have not provided a clear-cut threshold [17,18]. In addition, previous studies of this relationship have been constrained by several methodological limitations.

Most studies, for example, relating newborn colonization to maternally-derived antibodies, with [19,20] or without maternal vaccination [21–23], have failed to account for the colonization status of the mother at birth. Children born to carrier mothers have a higher risk of infection by the mother and are also likely to receive higher antibody concentrations by passive transfer, thus confounding the relationship between antibody concentration and carriage.

Secondly, the ascertainment of carriage acquisition in infants has been relatively insensitive. The earliest swabs were obtained at no younger than 1 month of age [20–25] and the period between subsequent swabs was also at least a month in all of the studies. Thirdly, previous studies have been undermined by the relatively small sample sizes, which limits the power to

detect modest protective efficacies. Clinical trials of maternal vaccination studied samples of both vaccinated and control children ranging in size from 46 to 437 infants [14] and studies without maternal vaccination had sample sizes in the range 51-310 [21–23,25]. Finally, only one previous study has measured both anti-capsular and anti-protein antibodies in the mother-infant pairs and, even here, they were assessed independently [25].

Understanding the association between maternally-derived antibodies and the rate of carriage acquisition for a panel of pneumococcal proteins and capsular polysaccharides is likely to guide antigen selection in future maternal/newborn immunization strategies. We aimed to characterize this association using a study where the carriage status of the mother at birth is already known; the ascertainment of carriage in the infant begins early and recurs frequently; the study population is of sufficient size to detect moderate associations; and the effects of anti-protein and anti-capsular antibodies are analyzed simultaneously to determine the independent protective efficacies of each.

Methods

Data

The study population and design have been described in detail elsewhere [1]. The study was conducted before the introduction of PCV vaccination in Kenya. Briefly, we collected nasopharyngeal swab specimens from participating newborns, aged at most 7 days, twice weekly for 2 weeks and weekly thereafter until a pneumococcus was cultured from an infant's swab or until 13 weeks after study entry, whichever was the sooner. Mothers were

swabbed at the time of birth and monthly thereafter. Cord blood was collected at the time of birth if the delivery took place at the hospital. Venous blood was collected from the mother if the child was born at home and reported to hospital within 7 days.

The environmental risk factors for carriage ascertained were: sex, mother's HIV status, history of cough, history of coryza, observed cough, observed coryza, observed runny nose and breastfeeding status. At the household level we ascertained: type of fuel used for cooking, number of siblings aged <10 years, number of other children aged <10 years, number of adults, number of smokers and number of carers.

Laboratory methods

A direct binding electrochemiluminescence-based multiplex assay [26] was used to measure serum IgG antibodies to 27 pneumococcal protein antigens. Pneumococcal reference serum 007sp was used as a standard and assigned a value of 1000 arbitrary units for each antigen [27]. Antibody levels in serum samples were expressed as concentrations with reference to the amount in 007sp.

We used ELISA to assay serum samples for antibodies to 6A, 6B, 14, 19F and 23F capsular polysaccharides as described previously [28]. The assays were done at the WHO reference laboratory for pneumococcal serology, University College London Institute of Child Health, UK. These five serotypes

were chosen because they were the serotypes most frequently acquired in the study.

Statistical analysis

Univariable Cox proportional hazard (Cox PH) models were fitted to assess the relationship between the hazard of acquisition of carriage and anti-protein antibody concentrations for each of the 27 proteins. Non-linear effects of antibodies were modeled using restricted cubic splines [29]. The univariable Cox PH models were also fitted for homologous carriage against serotype-specific anti-capsular antibody concentrations. Subjects were censored upon acquiring any pneumococcal serotype. For serotype-specific analyses this introduces a competing-risk scenario. Therefore, instead of estimating the standard hazard rates, we estimated the cause-specific hazard rates [30].

The principal problem with serotype-specific analyses is power, since only a subset of all pneumococcal acquisitions are used. We replicated timespan records for each individual four times resulting in five copies. We then associated each replicate record with a standardized log IgG concentration, as well as an indicator for acquisition, for each of the five serotypes. The log IgG concentrations were standardized using serotype-specific means and standard deviations. This restructured dataset allowed us to estimate the impact of anti-capsular antibodies on the acquisition of any of the five serotypes in a single model. We calculated cluster robust standard errors to account for the correlation introduced by replication.

We used the Least Absolute Shrinkage and Selection Operator (lasso) penalty to select anti-protein antibodies and environmental risk factors to retain in multivariable Cox PH models. We assumed that these factors were independent of serotype and therefore examined their effect by fitting a penalized Cox PH model with acquisition of any pneumococcus as outcome. The lasso procedure shrinks the coefficients of the less relevant variables to zero and results in a set of variables that have optimal predictive value. Simulations indicate that the lasso procedure can be more accurate than stepwise selection [31]. In the presence of strong correlations between candidate predictors, the lasso may not be consistent in variable selection [32]. Consistency here refers to a higher ability to recover the correct model with growing number of observations. To achieve consistency we used an ensemble voting approach [33]. This involved fitting the penalized model to the observed dataset and across 200 bootstrap-resampled datasets, and using this pool of estimated coefficients to vote on which variables to include in the model. A variable was selected if its coefficient was not reduced to zero in more than 50% of the resampled datasets, a threshold that is a balance between being too restrictive or too lenient.

We estimated non-linear effects on acquisition of any serotype of each selected anti-protein antibody adjusting for selected environmental variables and remaining selected protein variables. All the Cox PH models of the effect of anti-capsular IgG on the hazard of serotype-specific acquisition were adjusted for the selected environmental and protein variables. In these models, we entered the anti-capsular or anti-protein IgG coefficient of interest

unpenalized unlike the rest of the predictors used in adjustment. We also estimated non-linear effects on acquisition of the five serotypes of each selected protein antibody adjusting for selected environmental variables, the remaining selected protein variables and the standardized anti-capsular antibodies. Anti-capsular concentrations below the minimum detectable limit of 0.15 mcg/ml were imputed as half the value i.e. $0.15/2=0.075$. All anti-protein and anti-capsular concentrations were log-transformed before analysis.

Results

Acquisition rates

Cord or venous blood samples were collected from 976 newborns; 342 (35%) of these were venous blood. The newborns were followed for a total of 33,905 days resulting in 561 acquisitions of pneumococcus; 218 (39%) of these were for serotypes 6A, 6B, 14, 19F and 23F. The rate of acquisition per infant per 1000 days ranged from 0.77 for serotype 14 to 2.18 for serotype 19F (Table 1).

Univariable analyses

Higher levels of anti-protein IgG were associated with reduction in acquisition of any serotype for a number of proteins; nearly monotonic relations between acquisition hazard and IgG level were estimated for PhtD1, PhtD2, PhtE and StkP ($p>0.15$ for each). Higher anti-protein antibodies to PiaA, RrgBT4, RrgB6B and RrgB23F were associated with increased acquisition of carriage ($p<0.033$ for each) (Figure S1).

The serotype-specific hazard of acquisition as a function of homologous log IgG concentration did not show a monotonically decreasing trend with higher concentrations (Figure 1). For serotypes 14 and 19F, there was favorable reduction in acquisition hazard at higher IgG levels. In the joint analysis combining all five serotypes, higher anti-capsular IgG concentrations, on the extreme right of the distribution of IgG concentrations, were associated with a reduction in acquisition (Figure 2) however we did not find evidence of an association across the whole range of values ($p=0.797$). The point-wise confidence intervals (CIs) in the figures, at the upper bound descends below the hazard ratio (HR) of 1; this can be used to mark log IgG levels which result in a significant reduction in carriage rates compared to typical (mean) log IgG values. In the univariable analysis, the upper limits of the CIs are all above a HR of 1.

Multivariable analyses

Table 2 shows the set of environmental and anti-protein antibody variables selected by the lasso procedure. In the set of candidate environmental predictors, sex, history of cough, observed cough, observed runny nose and breastfeeding status were voted out of the model. Among the 27 candidate anti-protein antibody predictors, 17 were voted out. Except for antibodies to PhtD1, PspAFam2, StkP and Spr0096, in which higher concentrations were associated with reduction in carriage acquisition, higher IgG levels for the remaining proteins were associated with increased acquisition (Table 2). The group of newborns who were born in hospital, had a lower rate of

pneumococcal acquisition (18% lower) compared to newborns who were born at home (Table 2).

Among the ten proteins in which adjusted non-linear effects on carriage acquisition were analysed, higher concentrations of PhtD1 and StkP were associated ($p=0.020$ and 0.036 , respectively) with reduced acquisition. Higher concentrations of RrgBT4 were associated ($p=0.003$) with an increase in acquisition rate for the greater part of the distribution of anti-RrgBT4 antibodies (Figure 3). The function for anti-RrgBT4 concentration was non-monotonic; we also observed higher carriage rates in the lower tail of the distribution. The effects of the anti-protein concentration on acquisition of any of the five serotypes without adjusting for the anti-capsular concentrations (Figure S2) were similar with adjustment (Figure S3).

Adjusting for environmental and anti-protein antibody variables in the models of the effect of serotype-specific anti-capsular antibodies only marginally influenced the shape of the hazard functions compared to the unadjusted analyses. In serotype 19F there was lower risk in the upper tail of the distribution of IgG concentration, however, there was no evidence an overall effect of serotype-specific IgG ($p=0.13-0.97$) (Figure 4). In the joint multivariable analysis of all the five serotypes, individuals with standardized log IgG concentration of about 2 and above had significant reduction in the rate of acquisition, by 50% or more, compared to individuals with the average standardized log IgG (Figure 2, right panel). A standardized log IgG

concentration of 2 is equivalent to an absolute IgG concentration of 11.1, 9.8, 3.1, 5.5 and 19.0 mcg/ml for serotypes 6A, 6B, 14, 19F and 23F, respectively.

Discussion

We assessed the association between maternally-derived anti-protein and anti-capsular antibodies and the rate of carriage-acquisition in the first 90 days of life among mother-infant pairs in the pre-vaccination period in Kenya. Among anti-protein antibodies, we found that higher concentrations of antibody to some proteins (PhtD1, PspAFam2, Spr0096 and StkP) were associated with a reduction in the acquisition rate while some (CbpA, LytC, PcpA, PiaA, PspAFam1 and RrgBT4) were associated with an increase in acquisition rate (Figure 3).

Some of the associations are consistent with our understanding of the protein functions. For instance, higher anti-protein antibodies to histidine triad protein (PhtD) were significantly associated with a reduction in acquisition. PhtD is a pneumococcal cell surface protein that contributes to the adherence of *S. pneumoniae* to epithelial cells [34]. This protein has been used as a vaccine candidate [35].

Several associations are apparently inconsistent with known functions of the proteins. The presence of pilus has been implicated in adhesion to epithelial cells in humans and mice [36], suggesting a role in colonization. RrgB is a backbone subunit of pneumococcus pilus-1, anti-RrgBT4 antibody binding to pilus might reduce its capacity to bind epithelial cells and thereby abrogate its

role in adhesion. Therefore, higher anti-RrgBT4 concentrations would result in lower carriage acquisition. The pneumococcal serine threonine protein kinase (StkP) has recently been shown to repress the expression of pilus and modulate bacterial adherence to human epithelial cells [37]. Thus, higher anti-StkP antibodies imply impaired repression of the pilus in the pneumococcus enhancing the attachment capacity of the bacterium, leading to increased carriage acquisition.

However, we observed a non-monotonic relation between carriage acquisition anti-RrgBT4 concentrations; the hazard was higher at the lower and upper extremes of the concentration scale. We also observed a significant reduction in acquisition rate with increasing anti-StkP concentrations (Figure 3). The pilus is only expressed in 30-50% of pneumococci [38], therefore any effect mediated through pilus is likely to be diluted, thus the observed effect of anti-RrgBT4 and anti-StkP antibodies might not be entirely explained through their effect on the pilus. We did not determine pilus phenotypes of pneumococci isolated in this study, so we were unable to include the phenotype in our analysis. Nonetheless, StkP is a global kinase involved in regulating a number of pneumococcal functions that are critical for the resistance of pneumococcus to various stress conditions, one such function is cell wall biosynthesis [39]. Antibodies to StkP may inhibit the role it plays in cell wall development and that would lead to a decrease in pneumococcal viability and therefore reduced carriage. Some of these paradoxical associations may be due to the observational nature of the study, where it is difficult to control completely for confounding; the findings could be tested in an experimental

design using nasopharyngeal challenge studies in animal models.

Understanding both the positive and negative impacts of antibodies on adhesion may be useful for vaccine design.

Several prior studies have documented the limited role of maternally-derived antibodies in protecting infants from pneumococcal colonization [21,22,40].

Maternal vaccination in the third trimester of pregnancy increases the amount of antibody passed on to the newborn [20,41]. However, there is insufficient evidence that maternal vaccination during pregnancy could reduce infant carriage or infections [42].

We observed a reduction in the rate of acquisition associated with high levels of maternally-derived anti-capsular antibodies to five serotypes even though none of the associations was statistically significant across the whole range of concentrations (Figure 2&4). The limited effect of anti-capsular antibodies on carriage acquisition rates in our study could suggest that these antibodies are not effective against carriage acquisition, at least in an environment such as Kilifi with a high force of infection. However, we did observe a steep reduction in acquisition of carriage at very high concentration of antibodies in the range of 3.1-19.0 mcg/ml across different serotypes, though concentrations this high were attained by only about 3% of the newborn population (Figure 2). In other settings the proportion attaining these concentrations at birth might be higher; about 25% of newborns had these level of antibodies for serotypes 14 and 19F in a study of American children [43]. This provides some rationale for maternal vaccination, if the vaccine can raise the level of transferred

antibodies to very high concentrations above those observed as a consequence of repeated natural exposure.

One limitation of the analysis is that the HIV status of the mothers was not considered. Immunosuppressed mothers are more likely to be colonized by pneumococcus and have reduced immunological responses following colonization [44]. Therefore, HIV positive mothers are more likely to transmit pneumococcal carriage to their newborns and transfer lower antibody concentrations to their newborns compared to HIV negative mothers.

Consequently, the association between maternal antibodies and the risk of acquisition of carriage among children born to HIV positive mothers is likely to be stronger (large effect size) compared to the same association among children born to HIV negative mothers. Not accounting for mother's HIV status might therefore bias upwards the estimate of the hazard of acquisition per unit increase in maternal antibodies. The magnitude of this bias in a study population would depend on the prevalence of HIV among women in the childbearing age, where a small prevalence of HIV would reduce the bias. The prevalence of HIV in women in coastal Kenya reduced from 11% 2007 to 4% in 2012 [45], the period between which data analysed in this study was collected.

There are few analyses of CoP against carriage acquisition for anti-capsular antibodies. A value of 5mcg/ml was associated with protection against carriage of serotype 14 [17]. Our analysis suggests that the CoP is likely to be very high, in the range 3.1-19.0 mcg/ml. In the only reported study of maternal

vaccination with a PCV, the geometric mean concentrations (GMC) of anti-capsular antibodies in cord-blood of newborns to vaccinated mothers were between 3 and 19 times higher, depending on serotype, compared to newborns to mothers who received a placebo. The GMC in cord-blood among newborns from vaccinated mothers ranged between 2.4 to 14.3 mcg/ml [13]. This increases the potential of PCVs for use in maternal vaccination.

The serotype-specific rates of acquisition observed among the subset of newborns whose cord or maternal venous blood were collected were very similar to the total sample of 1400 newborns that constituted the original study [1] suggesting that the subset analysed was representative (Table 1). The newborns born in hospital, had lower rates of pneumococcal acquisition compared to those born at home. The blood type (cord or venous) provided was therefore a potential confounder in the relationship between antibodies and carriage acquisition. However, we adjusted for blood type in all multivariable models.

In conclusion, we observed a significant association between carriage acquisition and several anti-protein antibodies but only a limited role for maternally-derived anti-capsular antibodies, at high concentrations, on serotype-specific acquisition of pneumococci. This disparity between anti-protein and anti-capsular effects may be attributable to differential study power, as the anti-capsular analyses was restricted to homologous acquisitions but the anti-protein analysis included all acquisitions. Nonetheless, a strategy of maternal vaccination to improve the level of

transferred antibodies and thus protect newborns against acquisition of carriage may be successful if vaccine formulation is focused on enhancing specific anti-protein antibodies that are associated with reduced carriage, or if the strategy induces very high concentrations of anti-capsular antibodies, above those normally observed in physiological trans-placental transfer.

Funding

The study was funded by the Wellcome Trust, through research fellowships [098532 to JAGS and 092767 to JO].

Conflicts of Interest

DG is funded by the NIHR and his laboratory undertakes collaborative and contract research for GSK who make PCV. DG attends occasional advisory boards convened by GSK.

Ethics statement

The study was approved by the Kenya Medical Research Institute (KEMRI) Ethical review committee (Protocol number, SCC 2273). This paper is published with the permission of the Director, Kenya Medical Research Institute. We thank Nicola Green for performing the pneumococcal serology.

References

1. Tigoï CC, Gatakaa H, Karani A, et al. Rates of acquisition of pneumococcal colonization and transmission probabilities, by serotype, among newborn infants in Kilifi District, Kenya. *Clin. Infect. Dis.* **2012**; 55:180–8.
2. Turner P, Turner C, Jankhot A, et al. A Longitudinal Study of *Streptococcus pneumoniae* Carriage in a Cohort of Infants and Their Mothers on the Thailand-Myanmar Border. *PLoS One* **2012**; 7:e38271.
3. Coles CL, Rahmathullah L, Kanungo R, et al. Vitamin A supplementation at birth delays pneumococcal colonization in South Indian infants. *J. Nutr.* **2001**; 131:255–261.
4. Simell B, Auranen K, Käyhty H, et al. The fundamental link between pneumococcal carriage and disease. *Expert Rev. Vaccines* **2012**; 11:841–55.
5. Ndiritu M, Karani A, Nyiro J, et al. Epidemiology of invasive pneumococcal disease among children in Kilifi District, Kenya. In: Sixth International Symposium on Pneumococci and Pneumococcal Diseases. Reykjavik, Iceland: 2008: [abstract P1-059].
6. Whitney CG, Goldblatt D, O'Brien KL. Dosing Schedules for Pneumococcal Conjugate Vaccine. *Pediatr. Infect. Dis. J.* **2014**; 33:S172–S181.
7. Shiri T, Datta S, Madan J, et al. Indirect effects of childhood pneumococcal conjugate vaccination on invasive pneumococcal disease: a systematic review and meta-analysis. *Lancet Glob. Heal.* **2017**; 5:e51–e59.
8. Davis SM, Deloria-Knoll M, Kassa HT, O'Brien KL. Impact of pneumococcal conjugate vaccines on nasopharyngeal carriage and invasive disease among unvaccinated people: Review of evidence on indirect effects. *Vaccine* **2013**; 32:133–145.
9. Hammitt LL, Akech DO, Morpeth SC, et al. Population impact of 10-valent pneumococcal conjugate vaccine (PCV) on nasopharyngeal

- carriage of *Streptococcus pneumoniae* in Kilifi, Kenya. In: 10th International Symposium on Pneumococci & Pneumococcal Diseases. Glasgow, Scotland.: 2016.
10. Roca A, Bojang A, Bottomley C, et al. Effect on nasopharyngeal pneumococcal carriage of replacing PCV7 with PCV13 in the Expanded Programme of Immunization in The Gambia. *Vaccine* **2015**; 33:7144–7151.
 11. Scott JAG, Ojal J, Ashton L, Muhoro A, Burbidge P, Goldblatt D. Pneumococcal Conjugate Vaccine Given Shortly After Birth Stimulates Effective Antibody Concentrations and Primes Immunological Memory for Sustained Infant Protection. *Clin. Infect. Dis.* **2011**; :1–8.
 12. Pomat WS, van den Biggelaar AHJ, Phuanukoonnon S, et al. Safety and Immunogenicity of Neonatal Pneumococcal Conjugate Vaccination in Papua New Guinean Children: A Randomised Controlled Trial. *PLoS One* **2013**; 8:1–12.
 13. Daly KA, Scott Giebink G, Lindgren BR, et al. Maternal immunization with pneumococcal 9-valent conjugate vaccine and early infant otitis media. *Vaccine* **2014**; 32:6948–6955.
 14. Clarke E, Kampmann B, Goldblatt D. Maternal and neonatal pneumococcal vaccination - where are we now? *Expert Rev. Vaccines* **2016**; 584.
 15. Feldman C, Anderson R. Review: Current and new generation pneumococcal vaccines. *J. Infect.* **2014**; 69:309–325.
 16. Andrews NJ, Waight PA, Burbidge P, et al. Serotype-specific effectiveness and correlates of protection for the 13-valent pneumococcal conjugate vaccine: A postlicensure indirect cohort study. *Lancet Infect. Dis.* **2014**; 14:839–846.
 17. Goldblatt D, Hussain M, Andrews N, et al. Antibody responses to nasopharyngeal carriage of *Streptococcus pneumoniae* in adults: a longitudinal household study. *J. Infect. Dis.* **2005**; 192:387–93.
 18. Ojal J, Hammitt LL, Gaitho J, Scott JAG, Goldblatt D. Pneumococcal

- conjugate vaccine induced IgG and nasopharyngeal carriage of pneumococci: Hyporesponsiveness and immune correlates of protection for carriage. *Vaccine* **2017**; 35:4652–4657.
19. Lopes CRC, Berezin EN, Ching TH, Canuto JDS, Costa VO Da, Klering EM. Ineffectiveness for infants of immunization of mothers with pneumococcal capsular polysaccharide vaccine during pregnancy. *Braz. J. Infect. Dis.* **2009**; 13:104–6.
 20. Munoz FM, Englund J a, Cheesman CC, et al. Maternal immunization with pneumococcal polysaccharide vaccine in the third trimester of gestation. *Vaccine* **2001**; 20:826–37.
 21. Lebon A, Verkaik NJ, Labout J a M, et al. Natural antibodies against several pneumococcal virulence proteins in children during the pre-pneumococcal-vaccine era: The generation R study. *Infect. Immun.* **2011**; 79:1680–1687.
 22. Holmlund E, Quiambao B, Ollgren J, Nohynek H, Käyhty H. Development of natural antibodies to pneumococcal surface protein A, pneumococcal surface adhesin A and pneumolysin in Filipino pregnant women and their infants in relation to pneumococcal carriage. *Vaccine* **2006**; 24:57–65.
 23. Rosen A, Håkansson A, Aniansson G, et al. Antibodies to pneumococcal polysaccharides in human milk: lack of relationship to colonization and acute otitis media. *Pediatr. Infect. Dis. J.* **1996**; 15:498–507.
 24. Lopes CC, Berezin EN, Scheffer D, et al. Pneumococcal Nasopharyngeal Carriage in Infants of Mothers Immunized with 23V Non-conjugate Pneumococcal Polysaccharide Vaccine. *J. Trop. Pediatr.* **2012**; 58:348–352.
 25. Turner P, Turner C, Green N, et al. Serum antibody responses to pneumococcal colonization in the first 2 years of life: results from an SE Asian longitudinal cohort study. *Clin. Microbiol. Infect.* **2013**; 19:E551-8.
 26. Marchese RD, Puchalski D, Miller P, et al. Optimization and validation of a multiplex, electrochemiluminescence-based detection assay for the

- quantitation of immunoglobulin G serotype-specific antipneumococcal antibodies in human serum. *Clin. Vaccine Immunol.* **2009**; 16:387–396.
27. Goldblatt D, Plikaytis BD, Akkoyunlu M, et al. Establishment of a new human pneumococcal standard reference serum, 007sp. *Clin. Vaccine Immunol.* **2011**; 18:1728–1736.
 28. Rose CE, Romero-Steiner S, Burton RL, et al. Multilaboratory comparison of *Streptococcus pneumoniae* opsonophagocytic killing assays and their level of agreement for the determination of functional antibody activity in human reference sera. *Clin. Vaccine Immunol.* **2011**; 18:135–142.
 29. Desquilbet L, Mariotti F. Dose-response analyses using restricted cubic spline functions in public health research. *Stat. Med.* **2010**; 29:1037–1057.
 30. Dignam JJ, Zhang Q, Kocherginsky MN. The Use and Interpretation of Competing Risks Regression Models. **2013**; 18:2301–2308.
 31. Tibshirani R. The lasso method for variable selection in the cox model. *Stat. Med.* **1997**; 16:385–395.
 32. Zhao P, Yu B. On model selection consistency of Lasso. *J. Mach. Learn. Res.* **2006**; 7:2541–2563.
 33. Sinnott JA, Cai T. Inference for survival prediction under the regularized Cox model. *Biostatistics* **2016**; :kxw016.
 34. Plumptre CD, Ogunniyi AD, Paton JC. Surface association of pht proteins of *streptococcus pneumoniae*. *Infect. Immun.* **2013**; 81:3644–3651.
 35. Prymula R, Pazdiora P, Traskine M, Rüggeberg JU, Borys D. Safety and immunogenicity of an investigational vaccine containing two common pneumococcal proteins in toddlers: A phase II randomized clinical trial. *Vaccine* **2014**; 32:3025–3034.
 36. Barocchi MA, Ries J, Zogaj X, et al. A pneumococcal pilus influences virulence and host inflammatory responses. *Proc Natl Acad Sci USA* **2006**; 103:2857–2862.

37. Herbert JA, Mitchell AM, Mitchell TJ. A Serine-Threonine Kinase (StkP) Regulates Expression of the Pneumococcal Pilus and Modulates Bacterial Adherence to Human Epithelial and Endothelial Cells In Vitro. *PLoS One* **2015**; 10:e0127212.
38. Harfouche C, Filippini S, Gianfaldoni C, et al. RrgB321, a fusion protein of the three variants of the pneumococcal pilus backbone RrgB, is protective In Vivo and elicits opsonic antibodies. *Infect. Immun.* **2012**; 80:451–460.
39. Saskova L, Nova L, Basler M, Branny P. Eukaryotic-Type Serine / Threonine Protein Kinase StkP Is a Global Regulator of Gene Expression in *Streptococcus pneumoniae*. *J. Bacteriol.* **2007**; 189:4168–4179.
40. Francis JP, Richmond PC, Pomat WS, et al. Maternal antibodies to pneumolysin but not to pneumococcal surface protein a delay early pneumococcal carriage in high-risk Papua New Guinean infants. *Clin. Vaccine Immunol.* **2009**; 16:1633–1638.
41. O'Dempsey TJ, McArdle T, Ceesay SJ, et al. Immunization with a pneumococcal capsular polysaccharide vaccine during pregnancy. *Vaccine* **1996**; 14:963–70.
42. Chaithongwongwatthana S, Yamasmit W, Limpongsanurak S, et al. Pneumococcal vaccination during pregnancy for preventing infant infection. *Cochrane Database Syst. Rev.* **2006**; :CD004903.
43. Becken ET, Daly KA, Lindgren BR, Meland MH, Giebink GS. Low Cord Blood Pneumococcal Antibody Concentrations Predict More Episodes of Otitis Media. *Arch Otolaryngol Head Neck Surg.* **2001**; 127:517–522.
44. Palmeira P, Quinello C, Ana L, Zago A, Carneiro-sampaio M. IgG Placental Transfer in Healthy and Pathological Pregnancies. *Clin. Dev. Immunol.* **2012**; 2012.
45. Davies K, Samuel O, Mamo U, et al. Prevalence and Incidence of HIV Infection, Trends, and Risk Factors Among Persons Aged 15–64 Years in Kenya: Results From a Nationally Representative Study. *J Acquir Immune Defic Syndr.* **2014**; 66.

Table 1: Acquisitions rates of serotypes

Serotype	Acquisitions	Incidence (per 1000 days)	95% CI	Incidence in larger cohort* (per 1000 days)
6A	45	1.33	0.97-1.77	1.49
6B	38	1.12	0.79-1.54	1.26
14	26	0.77	0.50-1.12	0.79
19F	74	2.18	1.71-2.74	2.54
23F	35	1.03	0.72-1.44	1.24

The total time at risk was 33,905 person-days.

**The incidence estimated from the cohort of 1400 that included all newborns; those who gave and those who did not give serum samples.*

Table 2: Adjusted hazard ratios quantifying the association of acquisition of any pneumococcal serotypes with selected environmental and anti-protein antibody variables

Variable	Hazard Ratio*	95% CI
Coryza observed at last visit	1.36	1.03-1.60
History of coryza at last visit	1.20	0.87-1.63
Runny nose at last visit	1.17	0.96-1.51
Fuel used for cooking		
Firewood	Ref.	
Charcoal	0.61	0.37-0.94
Paraffin	0.81	0.67-0.97
Gas	2.04	1.03-6.48
No. of Siblings	1.06	1.01-1.13
No. of carers in household	0.94	0.89-0.99
No. of children aged <10 years in household	1.08	1.01-1.16
No. of smokers in household	1.11	0.97-1.30
Mother positive of carriage around time of birth	1.58	1.06-2.06
Type of sample: Cord vs. Venous blood (Ref)	0.82	0.69-0.98
Month of Swab		
January	Ref.	
February	1.22	0.76-1.87
March	1.22	0.78-1.94
April	1.12	0.72-1.64
May	1.02	0.63-1.53
June	1.95	1.08-2.92
July	2.57	1.37-3.64
August	2.19	1.13-3.17
September	1.99	1.04-2.71
October	1.93	1.06-2.79
November	1.84	1.01-3.27
December	0.88	0.55-1.32
CbpA	1.17	1.00-1.35
LytC	1.17	1.01-1.32
PcpA	1.13	1.00-1.24
PhtD1	0.79	0.70-0.95
PiaA	1.16	1.02-1.27
PspAFam2	0.85	0.77-0.98
PspAFam1	1.07	0.99-1.19
RrgBT4	1.15	1.05-1.25
Spr0096	0.92	0.85-1.00
StkP	0.88	0.81-0.99

*The hazard ratios for the anti-protein antibodies should be interpreted as the hazard ratio per unit increase in log IgG concentration.

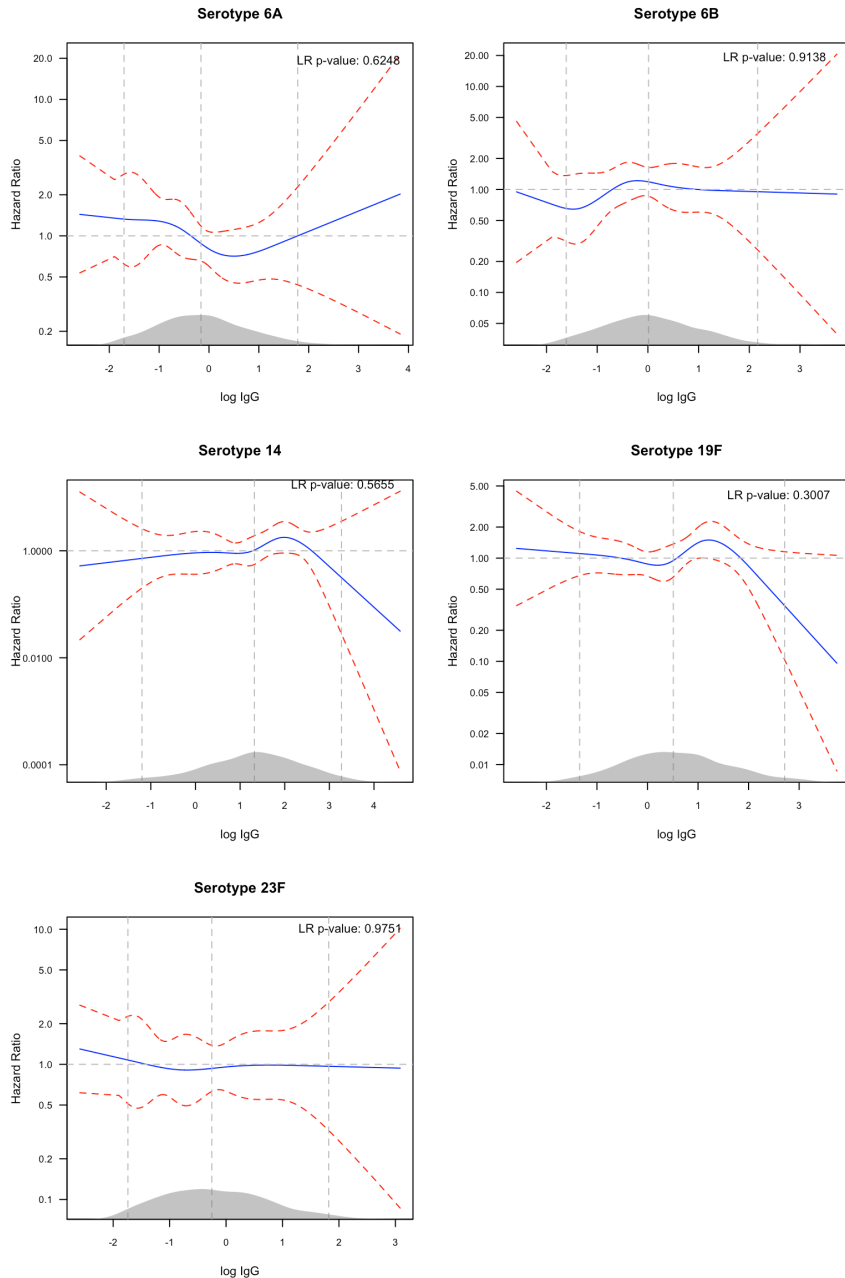

Figure 1: Univariable analysis of the effect of anti-capsular IgG on serotype-specific carriage acquisition rate. The figure shows the relative hazard of acquisition (blue solid line) as a function of log IgG concentration (x-axis) for each serotype labeled above the graph. The hazard at each level of log IgG is relative to the mean log IgG. The red dashed lines are the 95%CI bounds of the hazard ratio. The three vertical (grey) lines mark the 2.5th, 50th and 97.5th percentiles of the distribution of log IgG whose density is shown in grey on the x-axis. The likelihood ratio (LR) test p-value compares a model with and that without the log IgG concentration variable, thus indicating the overall significance of antibody concentration. The point-wise confidence intervals in the figures, at the point where the upper bound descends below the hazard ratio of 1, can be used to mark log IgG levels which results in significant reduction in carriage rates compared to typical (mean) log IgG values.

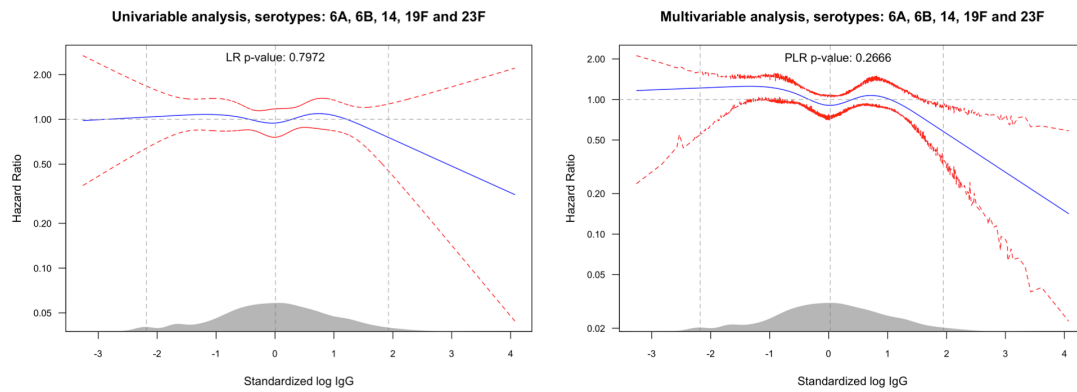

Figure 2: Univariable (left panel) and Multivariable (right panel) analysis of the effect of anti-capsular IgG concentration on carriage acquisition rates of any of the serotypes: 6A, 6B, 14, 19F and 23F. The figure follows the convention described in the legend for figure 1. The 95% CIs for the multivariable analysis are percentile-based and computed from 200 cluster bootstrap (clustered on subject/individual) resamples of the data. PLR stands for penalized likelihood ratio test, comparing a model with the log IgG concentration variable and one without.

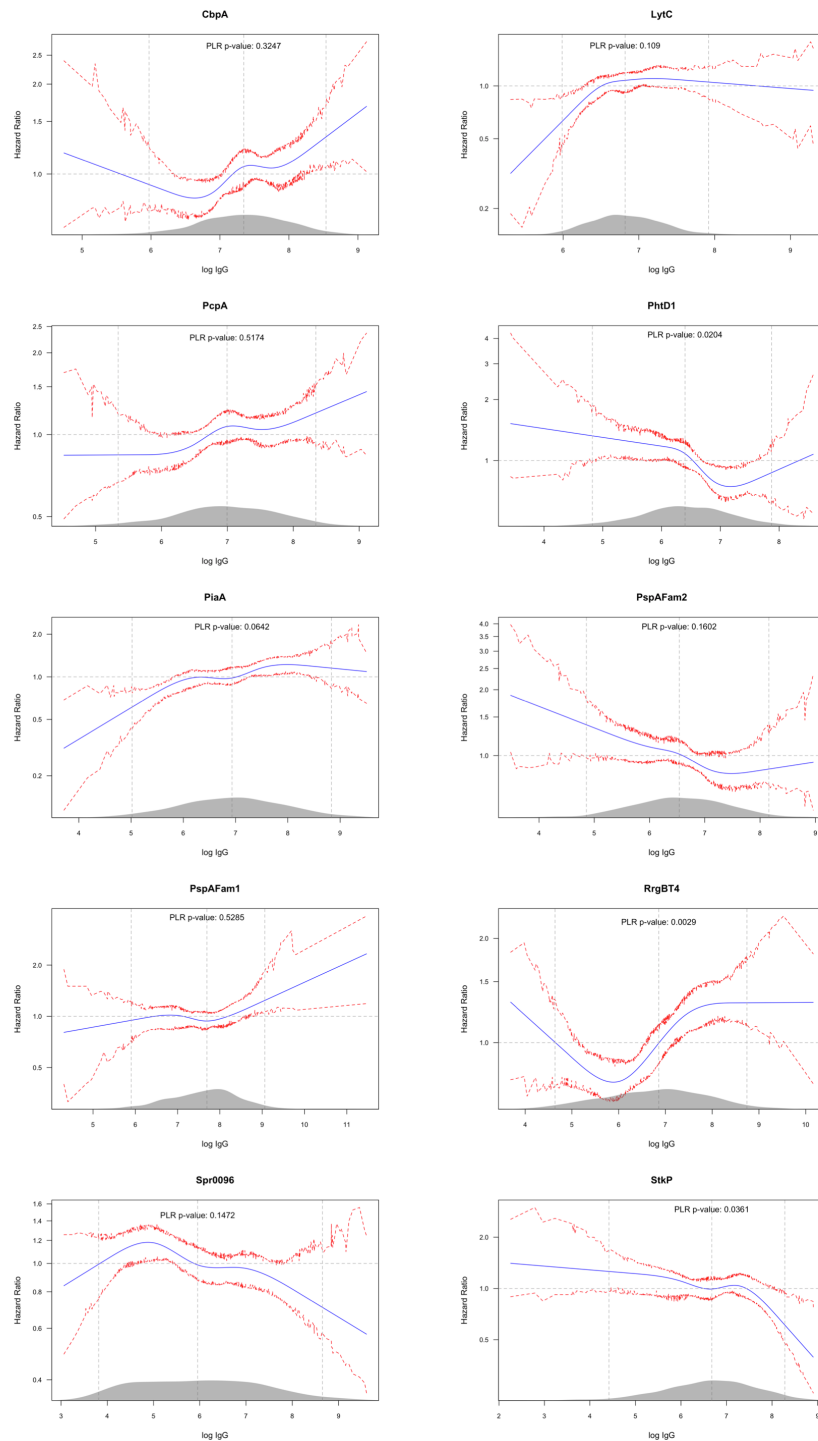

Figure 3: Multivariable analysis of the effect of the selected anti-protein IgG on all pneumococcal carriage acquisition rates. The figure follows the convention described in the legend for figure 1. The 95% CIs are percentile-based and computed from 200 cluster bootstrap (clustered on subject/individual) resamples of the data. PLR stands for penalized likelihood ratio test, comparing a model with the log IgG concentration variable and one without.

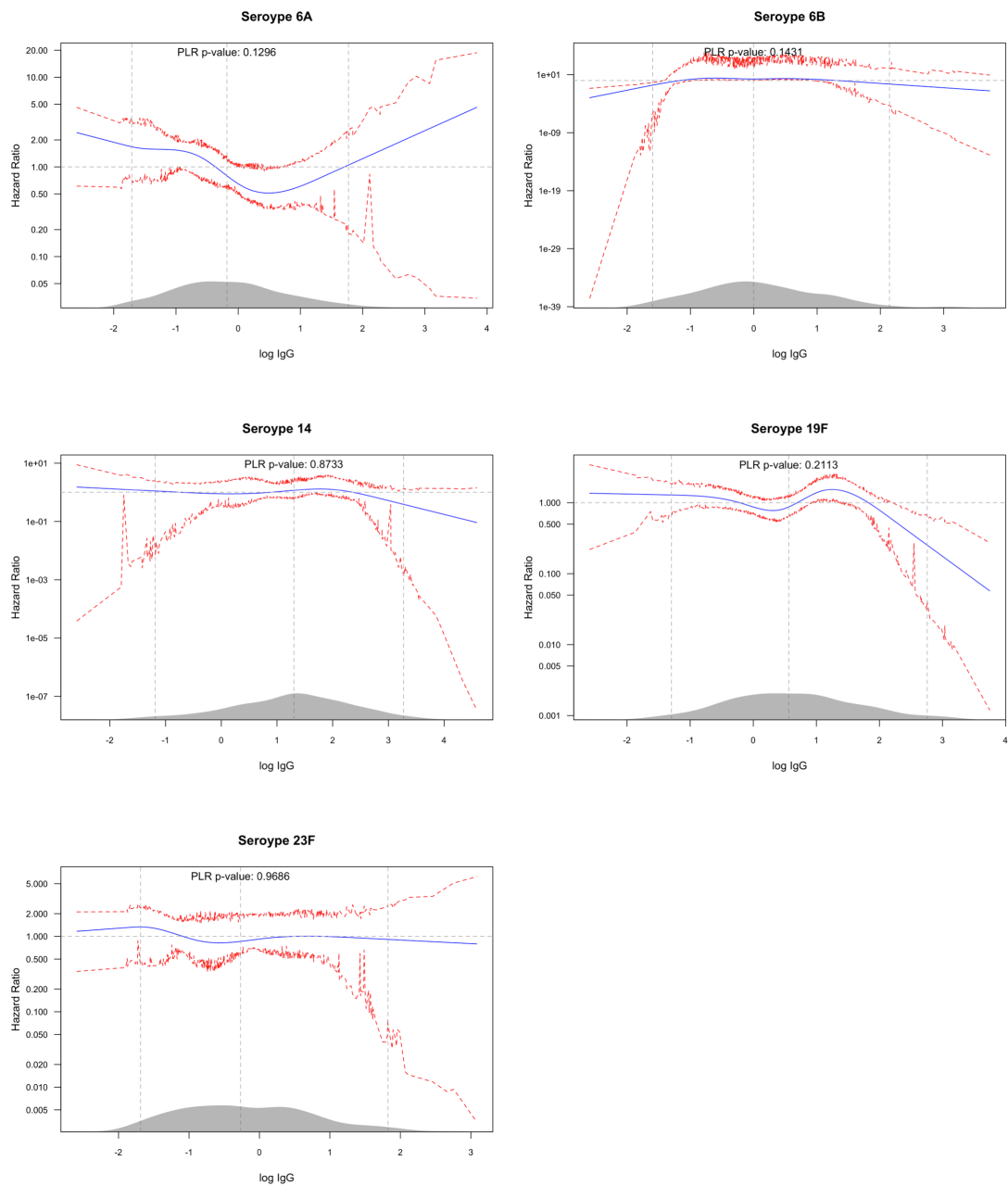
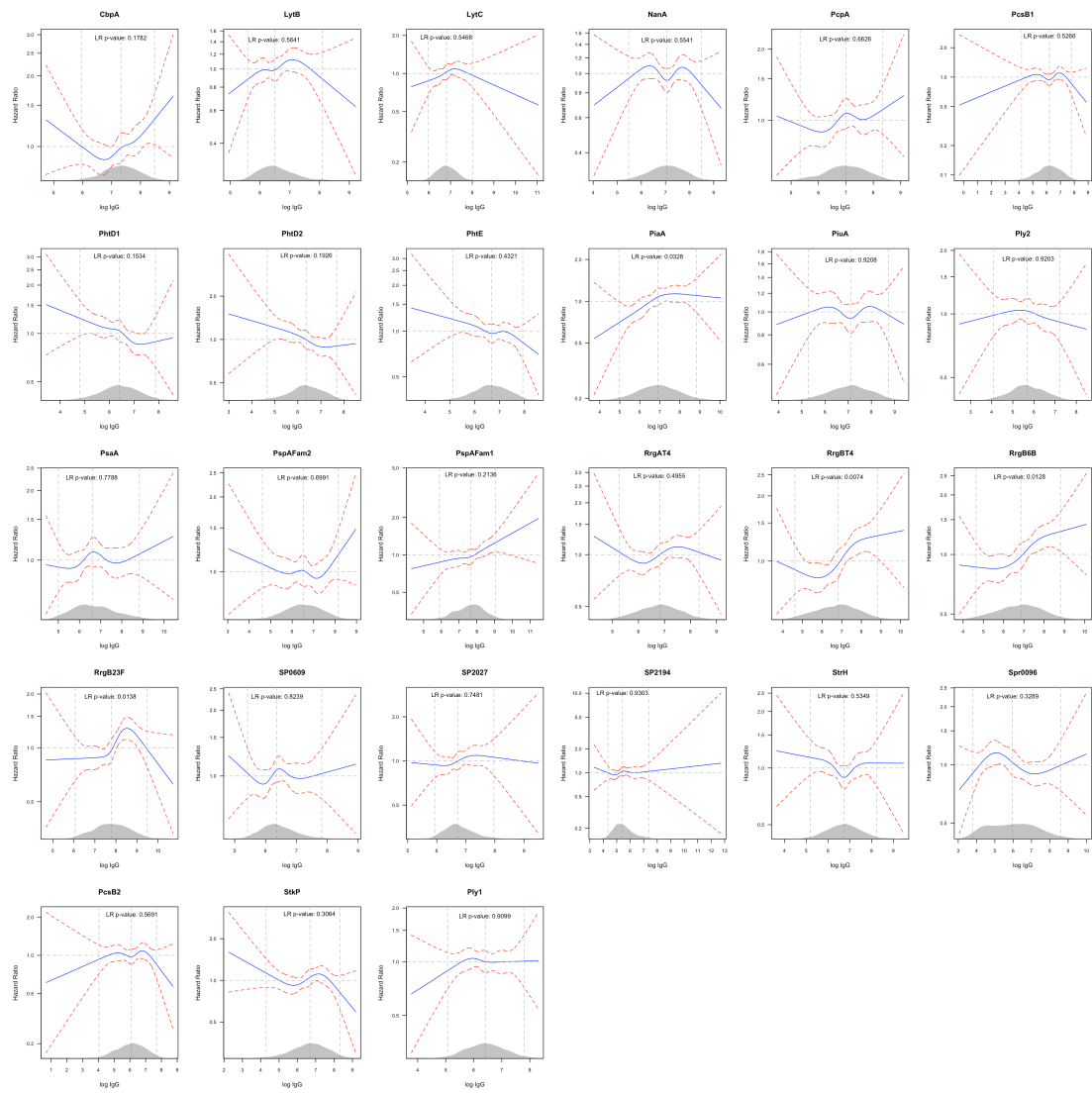
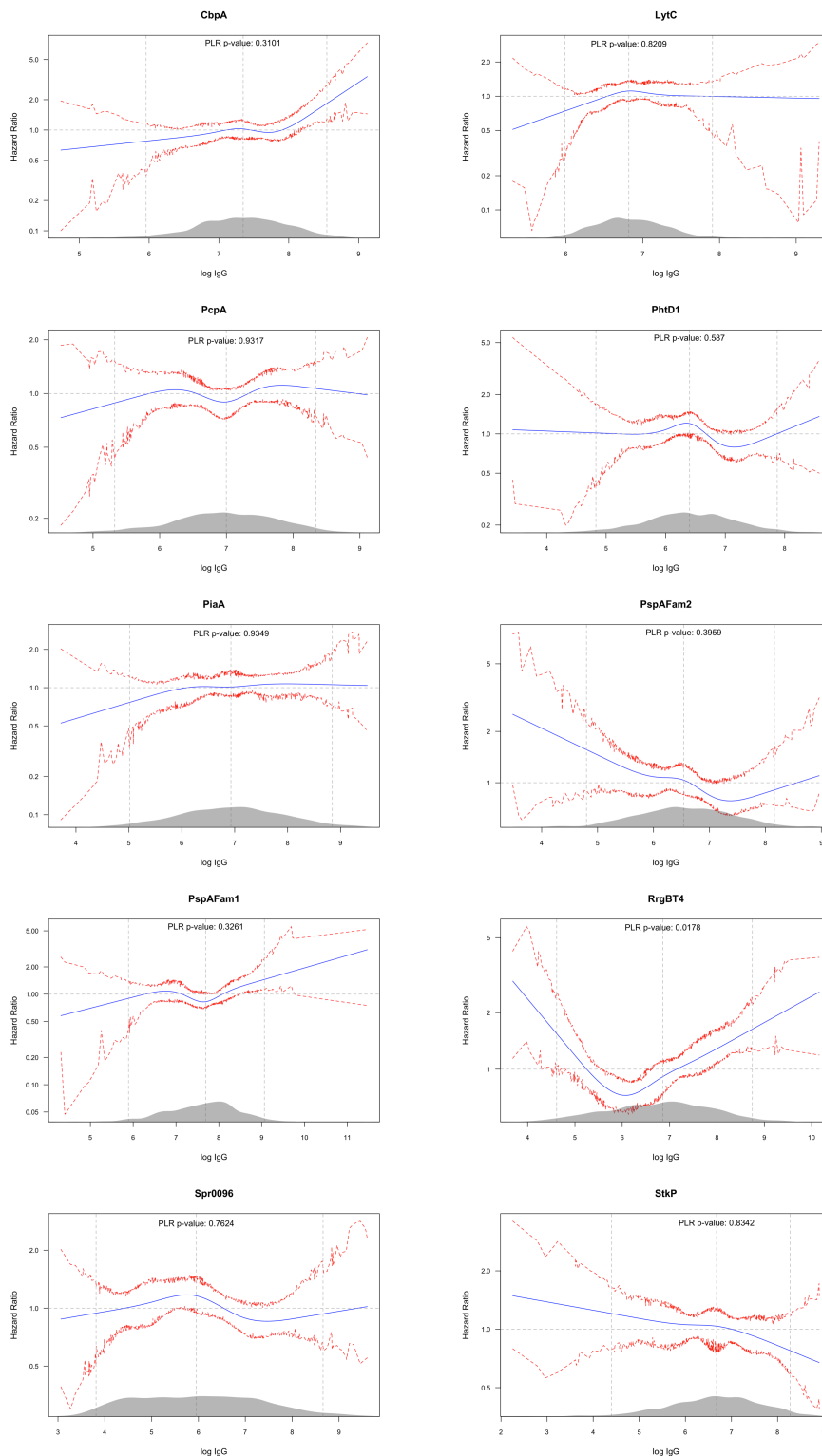

Figure 4: Multivariable analysis of the effect of anti-capsular IgG on serotype-specific carriage acquisition rate. The figure follows the convention described in the legend for figure 1. The 95% CIs are percentile-based and computed from 200 cluster bootstrap (clustered on subject/individual) resamples of the data. PLR stands for penalized likelihood ratio test, comparing a model with the log IgG concentration variable and one without.



Supplementary Figure S1: Univariable analysis of the effect of anti-protein IgG concentration on all pneumococcal carriage acquisition rates. The figure follows the convention described in the legend for figure 1.



Supplementary Figure S2: Multivariable analysis of the effect of anti-protein IgG concentration on carriage acquisition rates of any of the serotypes: 6A, 6B, 14, 19F and 23F not adjusting for anti-capsular antibodies. Adjustment variables for the functions presented in the plot include the environmental variables and rest of the selected anti-protein variables. The figure follows the convention described in the legend for figure 1.

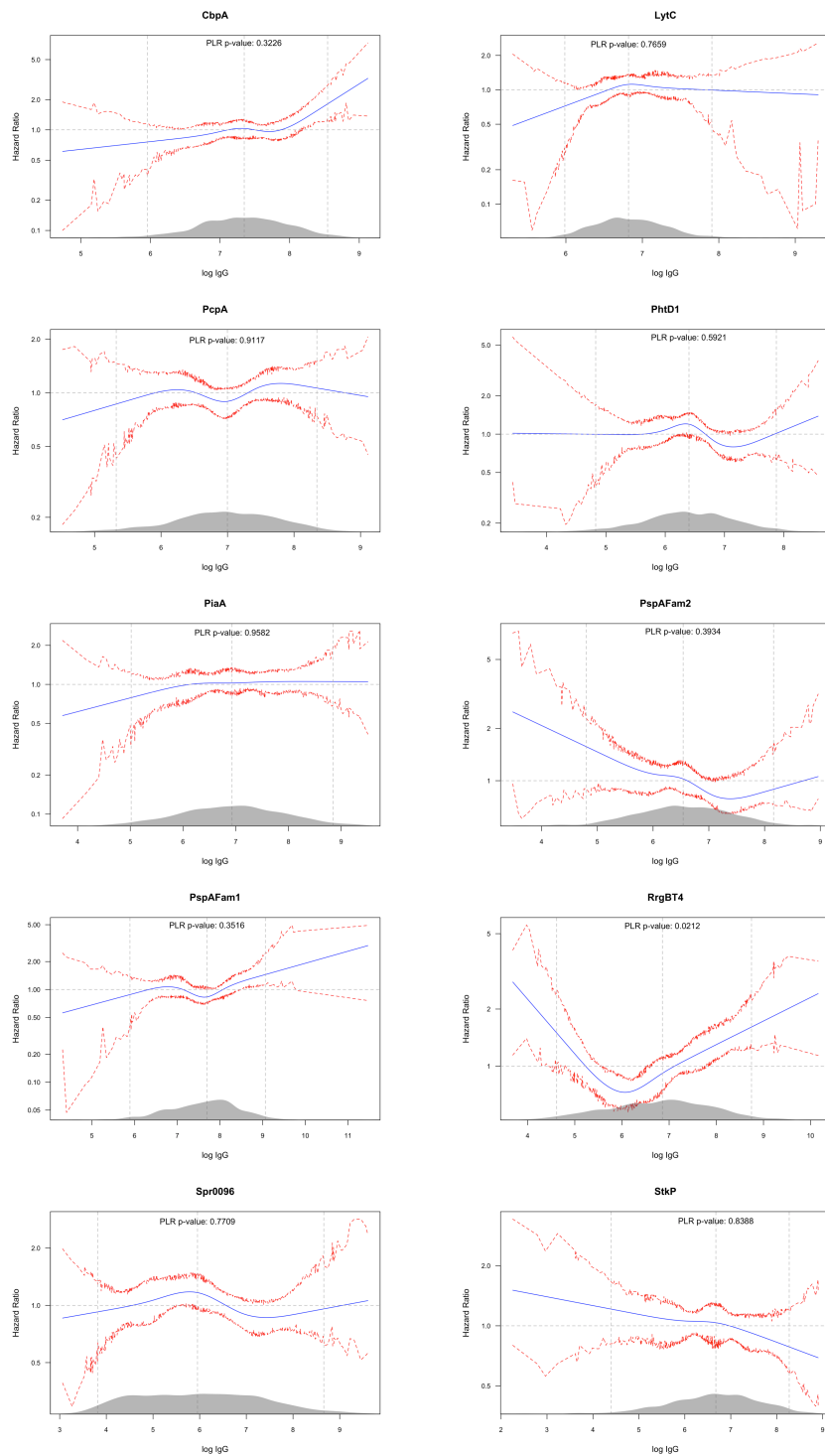

Supplementary Figure S3: Multivariable analysis of the effect of anti-protein IgG concentration on carriage acquisition rates of any of the serotypes: 6A, 6B, 14, 19F and 23F, adjusting for standardized anti-capsular antibodies.

Adjustment variables included the environmental variables, the rest of the selected anti-protein variables and standardized log anti-capsular antibodies of the five serotypes. The figure follows the convention described in the legend for figure 1.

Chapter 5: Research paper 4

Title: The merits of sustaining pneumococcal vaccination after transitioning from Gavi support – a cost-effectiveness study for Kenya

Author(s): John Ojal, Ulla Griffiths, Laura L. Hammitt, Ifedayo Adetifa, Donald Akech, Collins Tabu, J. Anthony G. Scott, Stefan Flasche

Journal/Publisher: Not decided

Type of publication: Original contribution

Stage of publication: Manuscript in preparation

Academic peer-reviewed: Reviewed by co-authors, pending further review after journal submission

Copyright: To be published as open access

Candidate's role:

I conceived the study together with Dr. Stefan Flasche. I developed the mathematical transmission models and implemented them in the R software to generate all the results presented in the manuscript. I wrote the first draft of the manuscript, reviewed and responded to all comments from co-authors. I will submit the manuscript and respond to all reviewer comments.

Candidate's signature:



Supervisor or senior author's signature to confirm Candidates role:



The merits of sustaining pneumococcal vaccination after transitioning from Gavi support – a cost-effectiveness study for Kenya

John Ojal^{1,2}, Ulla Griffiths⁴, Laura L. Hammitt^{1,2}, Ifedayo Adetifa^{1,2}, Donald Akech¹, Collins Tabu³, J. Anthony G. Scott^{1,2}, Stefan Flasche²

1. KEMRI-Wellcome Trust Research Programme, Centre for Geographic Medicine-Coast, Kilifi, Kenya
2. Department of Infectious Disease Epidemiology, Faculty of Epidemiology and Population Health, London School of Hygiene and Tropical Medicine, London, United Kingdom.
3. Kenya Ministry of Health, Nairobi, Kenya.
4. Department of Global Health and Development, London School of Hygiene and Tropical Medicine, London, United Kingdom.

Key words: pneumococcus; nasopharyngeal carriage; vaccination; mathematical modelling; cost-effectiveness; Kenya

Corresponding author:

John Ojal

PO Box 230- 80108

Kilifi, Kenya.

Tel +254 728 095 710

E-mail: jojal@kemri-wellcome.org

Abstract

Introduction

Most low-income countries have introduced pneumococcal conjugate vaccines (PCVs), all with substantial financial support from Gavi, the Vaccine Alliance. Within the next decade many of them will enter an accelerated transition phase and within the subsequent 5 years will need to either discontinue or gradually take over the full costs of their PCV programmes. Kenya introduced the ten valent PCV (PCV10) in 2011 and will enter Gavi transition in 2022. Using Kenya as a case study we assessed the cost-effectiveness of such strategies.

Methods

We fitted a dynamic compartmental model of pneumococcal carriage to annual carriage prevalence surveys and invasive pneumococcal disease (IPD) incidence in Kilifi obtained two years pre- and four years post- vaccine introduction and extrapolated this to the whole of Kenya. The incidence of pneumococcal sepsis, meningitis, bacteraemic pneumonia and non-bacteraemic pneumonia was estimated as a proportion of IPD incidence. The treatment costs of predicted cases of these four syndromes and vaccination cost of birth cohorts over a decade were estimated and used to calculate the costs per disability-adjusted-life-year (DALY) averted and associated predictive intervals (PI).

Results

We predict that overall IPD incidence will increase by 93% (PI: 72% - 114%) from 8.4 in 2022 to 16.3 per 100,000 per year in 2032, if vaccination is stopped. Continuing vaccination would prevent 15,355 (PI: 10,196–21,125) deaths and 112,050 (PI: 79,620–130,981) IPD and non-bacteraemic pneumonia cases during that time. The cost-effectiveness becomes more favourable as the effects of the current programme wane. The incremental cost per DALY averted of continuing PCV use versus discontinuing was predicted at \$142 (PI: 85 - 252) in 2032. We estimate that continuing the PCV programme after 2022 will require an additional US\$15.6 million annually compared to discontinuing vaccination. This is approximately triple Kenya's current annual immunization expenditure of US\$ 4.8 million.

Conclusion

Continuing PCV use is essential to sustain its health gains. Based on the Kenyan GDP per capita of \$1445, and in comparison to other vaccines, continued PCV use at full costs is still cost-effective. This supports an expansion of the vaccine budget, however, affordability may be a concern.

Introduction

The majority of African countries have introduced the pneumococcal conjugate vaccine (PCV) in their childhood immunization programmes which has led to a substantial reduction in pneumococcal disease [1,2]. In Kilifi, a coastal area in Kenya with enhanced surveillance for bacterial diseases, overall invasive pneumococcal disease (IPD) decreased by 68% in the post vaccination period (2012-2016) in children aged <5 years [3].

PCVs are among the most expensive vaccines available. However, most African countries did not undertake a cost-effectiveness analysis before deciding to introduce PCV as Gavi, the Vaccine Alliance, took over most vaccine costs. However, countries are expected to transition from Gavi support and subsequently take over the full cost once their average Gross National Income per capita over the past three years exceeds \$1580.

Currently four African countries (Angola, Congo Rep., Ghana and Nigeria) are in the accelerated transition phase [4] and five more (Ivory Coast, Lesotho, Sudan, Kenya and Zambia) are expected to join within the next five years.

With the increase in PCV costs upon transition countries will need to independently assess the cost-effectiveness and the affordability of sustaining the PCV infant vaccination programme.

Kenya introduced the 10 valent PCV (PCV10) in 2011 with Gavi's support and has recently entered the preparatory transition phase, which will see their current contribution of \$0.21 per dose increase by 15% every year. In 2022 Kenya will enter the accelerated transition phase that gradually increases their

cost contribution to 100% by 2027 [5]. Before entering the accelerated transition-phase Kenya will need to decide whether to continue with PCV vaccination and or discontinue the programme. We here assess the impact and cost-effectiveness of those two policy options.

Methods

We used a dynamic pneumococcal transmission model in combination with a costing model to estimate the cost-effectiveness of the two major policy options for PCV use in Kenya from 2022; i.e. continuation of PCV use at Gavi's scheduled prices or discontinuing the programme. The approach accounts for the uncertainty in both epidemiology and costing estimates and appropriately propagates it to the predicted outcomes.

Disease model and incidence prediction

The details of the transmission model are described elsewhere [6]. In brief, it is a compartmental, age-structured, dynamic model with 14 carriage states (Appendix, Supplementary Figure 3). The model has a Susceptible-Infected-Susceptible (SIS) structure for three serotype groups: the vaccine serotypes (VT), strongly competitive non-vaccine serotypes (sNVT) and weakly competitive non-vaccine serotypes (wNVT). We fitted the model to age stratified pre-vaccination (2009-2010) and post-vaccination (2011-2016) pneumococcal carriage data. This also allowed estimation of the vaccine efficacy against carriage.

In Kilifi, PCV vaccination was introduced together with a catch-up campaign in children <5 years old. To extrapolate findings to the rest of Kenya, where PCV

was introduced without a catch-up campaign, the fitted model was re-run under these conditions. We predicted carriage incidence for a 15-year period, from 2017 to 2032. We predicted IPD incidence by multiplying modelled carriage incidence with case-to-carrier ratios (CCR). For each model posterior the CCRs were calculated as the ratio of the observed pre-vaccination IPD incidence at Kilifi Country Hospital (KCH) [7] to modelled pre-vaccination carriage incidence. The CCR were assumed to remain unchanged post-vaccination.

IPD was defined as isolation of *Streptococcus pneumoniae* from a sterile site culture in an individual admitted to KCH. We split the predicted IPD incidence into the age dependent proportions that are pneumococcal meningitis, pneumococcal sepsis and bacteraemic pneumococcal pneumonia incidence based on the distribution observed in clinical data from KCH (Supplementary Table S1). We defined pneumococcal meningitis as isolation of *Streptococcus pneumoniae* from cerebrospinal fluid (CSF) or isolation of *S. pneumoniae* from blood, accompanied by a CSF white blood cell count of 50×10^6 cells/L or greater or a ratio of CSF glucose to plasma glucose less than 0.1. Bacteraemic pneumococcal pneumonia was defined as IPD with no pneumococcal meningitis but with WHO severe or very severe pneumonia. Pneumococcal sepsis was defined as IPD not meeting the definitions of pneumococcal meningitis or bacteraemic pneumococcal pneumonia. We further assume that for every prevented case of IPD one would prevent 5.3 cases of clinically-defined pneumonia [3,8]. This ratio was estimated by dividing the vaccine preventable clinical pneumonia incidence (351 per

100,000 per year) [3] to vaccine preventable IPD incidence (66.3 per 100,000 per year) [8] that were both estimated from surveillance at KCH.

Vaccination program costs

The program costs included vaccine costs, vaccine wastage, safety boxes, administering syringes for each dose, reconstitution syringes for each vial, syringe wastage and vaccine delivery cost (Table 1). The vaccine delivery cost included the vaccine supply chain cost and immunization service delivery cost. The initial investment in expanding the cold chain capacity in 2011 was not included. A switch from 2-dose to 4-dose presentation is expected during 2017. The 4-dose presentation has a preservative and once opened for the first time the vial can be kept for up to 28 days, therefore, Gavi expects no change in assumed vaccine wastage rates [9].

Treatment costs

We adopted a societal perspective in our analyses, i.e. including direct medical costs, the opportunity cost of caretaker time and household out-of-pocket costs. The hospital surveillance in KCH was found to underestimate the incidence of pneumonia and meningitis by 45% and 30% respectively [10]. We accounted for this age-independent under reporting in our analysis by inflating case numbers commensurately.

To apply the appropriate treatment costs, we divided the cases into three groups depending on where they were treated: hospitalised cases, cases treated as outpatients and those that did not reach medical care (Table 1). All

costs not referring to 2016 were expressed in 2016 US dollars for our analysis by using the International Monetary Fund's (IMF) GDP deflators for Kenya [11].

Disability Adjusted Life Years (DALYs)

The treatment costs for the predicted number of cases for the four syndromes considered and the vaccination cost of birth cohorts over a decade were estimated and used to calculate the costs per disability-adjusted-life-year (DALY) averted. Age weighting for the societal value of health loss was not considered in the analysis [12]. The years lost due to disability (YLD) were calculated as the product of disease incidence, duration of disease and disability weights. We used disability weights from the 2013 global burden of disease study [13] in calculating YLD component of DALYs. We used the disability weight of 0.133, assigned for infectious diseases with severe acute episodes, for both IPD and non-bacteraemic pneumonia episodes. For meningitis sequelae, we used a disability weight of 0.542 assigned for motor plus cognitive impairment. We assumed duration of 15 days for all IPD syndromes and 7 days for non-bacteraemic pneumonia. Meningitis sequelae were assumed to last a lifetime. We used the Kenyan age specific life expectancies [14] in calculating the Year of Life Lost (YLL) due to death. The discount rate on costs and DALYs was set at 3%.

Sensitivity analysis of the cost inputs and disease model

The full uncertainty of both epidemiological and costs parameters is propagated to the results as follows: for each posterior estimate of the

epidemiological model we sampled a set of cost parameters from the pre-set distributions, effectively combining probabilistic fitting of the epidemiological model with a probabilistic sensitivity analysis of the costing model (Table 1).

In Kenya, children who are carriers of VT pneumococci have been observed to respond less well to vaccine than non-carriers [15]. To assess structural uncertainty in our model we ran our analyses either with or without accounting for hyporesponsiveness. In the base case, we estimated a single vaccine efficacy independent of carrier status; in the sensitivity analysis, vaccine efficacy was estimated separately in vaccine-type carriers and in others. We also present two scenarios of discounting, i.e. discounting both costs and DALYs at 3% (base case) or discounting costs alone.

Results

Model fit and predicted IPD incidence

There was good agreement between the observed and fitted age-group and serotype-group specific carriage prevalence (Supplementary Figure 1 & Appendix). If cohorts of children born after the start of year 2022 are no longer vaccinated with PCV, the model predicts that IPD incidence will bounce back from 8.4, in 2022 to 16.3 per 100,000 per year in 2032 equalling pre PCV levels (Figure 1). Continuing with the PCV programme is predicted to result in additional small reductions in IPD incidence to 7.8 per 100,000 per year in 2032, and to avert 15,355 (PI: 10,196–21,125) deaths and 112,050 (PI: 79,620–130,981) IPD and non-bacteraemic pneumonia cases during the 11 years considered, if compared to discontinuing the PCV programme in 2022.

Estimated costs and cost effectiveness

The average annual treatment and vaccination costs for continuing the PCV programme during 2022-2032 were estimated as \$18,904,576. If vaccination was to be stopped in 2022 the estimated average annual treatment cost for pneumococcal disease in Kenya would be \$3,275,143 (Table 2).

Discontinuing the PCV programme was predicted to partially sustain direct and indirect protection from the vaccination of previous cohorts for much of the study period with only gradually declining impact on IPD incidence. As a result, we predict that continuation of the current PCV programme will not be cost effective initially. However, we show that within only one year after the decision to continue PCV vaccination the incremental cost-effectiveness ratio (ICER), in comparison to discontinuing the programme, rises substantially towards the threshold of the Kenyan GDP per capita (\$1455 in 2016) and continues to improve throughout the study period (Figure 2). Compared to discontinuing PCV in 2022, we predicted that, in 2032, the cost per DALY averted is \$142.7, the cost per case averted \$878.4 and the cost per death averted \$6386.8 (Table 2).

Sensitivity analyses

Using the Kenyan GDP per capita of \$1455 in 2016 as a threshold to determine cost effectiveness, all posterior samples indicated that continuation of PCV vaccination is cost effective no more than six years after 2022.

Compared to discounting both costs and DALYs, discounting costs alone resulted in an ICER that was twice as favourable (Table 2).

We estimate that the effect of hyporesponsiveness is relatively small. Vaccine serotype carriers had a vaccine efficacy estimate against carriage that was 4 percentage points lower than that for other vaccinees (Appendix, table A1). Hence omitting this mechanism in the model structure led to similar results (Supplementary Figure 2). Therefore, we did not include hyporesponsiveness in our final model.

Discussion

In the near future Kenya, like many other low income countries, will be expected to take over the full cost of the national pneumococcal conjugate vaccination programme [16]. In this study, we have estimated the cost-effectiveness of continuing with the vaccination programme using Gavi's schedule of vaccine prices, which reach a peak at \$3.05 per dose in 2027, at which point Kenya becomes fully self-financing. Our model projects that discontinuing the PCV vaccination programme would lead to an increase in IPD burden equivalent to pre-vaccination levels within ten years. Initially, however, continuing vaccination may not be cost-effective because of the benefits accrued through vaccination of previous cohorts. However, the cost-effectiveness becomes more favourable within a few years and, by 2032, the cost (in 2016 US dollars) plateaus at \$142.7 (\$85.1-\$252.4) per discounted DALY averted.

The most commonly used threshold for judging the cost-effectiveness of an intervention is a country's Gross Domestic Product (GDP) per capita. Using

this criterion, we find continuation of the PCV programme in Kenya after transition from Gavi support highly cost-effective. The GDP per capita threshold was initially supported by the Commission on Macroeconomics and Health [17] and adopted by WHO's Choosing Interventions that are Cost-Effective project (WHO-CHOICE). The use of GDP-based thresholds has been criticized because it: (i) does not consider potential benefits of other competing interventions; (ii) does not adequately address the willingness to pay; (iii) does not address affordability and (iv) is easily attained [18]. Alternatives include benchmarking interventions and league tables. A benchmark approach is a way of assessing willingness to pay by comparing cost-effectiveness ratios of the intervention under consideration with those of other interventions that have already been introduced. In the league table approach interventions are lined up in order of increasing ICER, then implemented in that order until the available budget runs out.

The cumulative costs per DALY averted of introducing the Rotarix or the RotaTeq rotavirus vaccines in Kenya have been estimated as \$200.1 and \$405.9 (2016 US Dollars) respectively, from a societal perspective [19]. The analysis was based on annual incidence of rotavirus associated diarrhoeal disease in children aged under 5 years estimated from national and sentinel surveillance data with 3% discounting on both cost and benefits, as in our current analysis. The *Haemophilus influenzae* type B (Hib) vaccine was introduced in 2001 Kenya as part of the pentavalent vaccine. In a static model developed to follow the Kenyan 2004 birth cohort until death, with and without Hib vaccine, it was estimated that the discounted (3% for both costs and

benefits) cost per DALY averted of introducing Hib vaccine was \$85 (2016 US Dollars) from a health provider perspective [20]. These ICERs suggest that continuation of the PCV programme is higher in value to the Hib vaccine programme and superior to the rotavirus vaccine programme. However, these comparisons must be tempered by the fact that the rotavirus analysis ignored herd immunity, which increases the ICER, while the Hib analysis took a health provider perspective, which reduces ICER.

Cost-effectiveness, however, does not necessarily imply affordability. The later depends on available resources in the health budget, or any other sources within the national accounts that can fill the gap in the health budget. Budgetary allocation to the health sector as a fraction of national government budget has slightly declined from 4% in financial year 2014/15 to 3.7% in financial year 2016/17 [21]. The Kenyan annual health budget for 2015 was \$600 million [21]. Out of this \$4.88 million (0.8%) [22] was spent on routine immunization. This has been possible because Kenya only needs to fund 10% of its routine immunization programme from its revenues, donors fund the rest of the budget [22]. We have estimated that continuing with the PCV vaccination after 2022 will require an additional \$15.6 million annually compared to discontinuing vaccination; in other words, it will more than triple Kenya current expenditure on vaccines.

Several initiatives indicate that the cost of the PCV programme may be reduced in future. For instance, the Serum Institute of India is developing of a 10-valent PCV with a target per-dose price of \$2.00 [23]. Also, in settings

where vaccine serotypes have been eliminated from circulation it may be possible to sustain control of transmission using a two-dose or even one-dose schedule[24]. If vaccine serotypes can be eliminated in Kenya, for example by additional efforts such as a catch-up campaign, then the shift to a reduced dose schedule may also be feasible. Most of these options will have a wider evidence base that may allow their formal consideration by 2022, however, currently there is insufficient support to include them in our analyses.

There are some potential limitations in our study. The proportion of pneumococcal disease cases that are hospitalized, treated as outpatients or do not access care is a key determinant of both costs incurred as well as DALYs, by determining the case fatality rate. Overestimating the proportion of cases that get hospital treatment would mean that the overall costs of treatment were overestimated while the fatal cases, and therefore DALYs, were underestimated. The overall effect would be an overestimated ICER, which is conservative. In our analysis, we estimated the proportion of cases that were hospitalized using local surveillance data [10]. However, we did not have local information on what proportion among unhospitalised cases are treated as outpatients; this was obtained from a Ugandan verbal autopsy study among fatal pneumonia cases [25]. It is possible, therefore, that we have overestimated the number of patients among unhospitalised treated as outpatients, and, by extension, overestimated the ICER.

Many low-income countries will soon be transitioning out of Gavi support and will need to decide whether to sustain their pneumococcal conjugate

vaccination programme. We demonstrate, using Kenya as an example, how ongoing detailed surveillance can be combined with mathematical modelling and health economics to inform an upcoming decision of a country's National Immunization Technical Advisory Group (NITAG) on the cost-effectiveness of different policy options. We estimate that maintaining the PCV programme is essential to sustain the decreased burden of pneumococcal disease and that it is cost-effective against conventional criteria. However, to afford PCV vaccination in the post-Gavi era, Kenya will need to substantially increase the proportion of health spending on routine immunization.

Author Contributions

Conceived the study: JO, UG, CL, JAGS, SF. Model coding and simulations: JO. Conducted the pneumococcal carriage surveys and/or facilitated IPD surveillance in Kilifi: LLH, DA, IA, JAGS. All authors: read and appraised the scientific content of the manuscript.

Ethics statement

The study was part of the Pneumococcal Conjugate Vaccine Impact Study (PCVIS) approved by the Kenya Medical Research Institute (KEMRI) Ethical review committee (SCC 1433). It has an additional approval by OXTREC (OXTREX 30-10), the Oxford Tropical Research Ethics Committee, with delegated authority from the London School of Hygiene & Tropical Medicine (LSHTM) Research Ethics Committee.

Acknowledgements

This paper is published with the permission of the Director, KEMRI. The work was funded by the Wellcome Trust through fellowship support to John Ojal (092767) and Prof. Anthony Scott (098532).

Conflict of interest: None.

References

1. Mackenzie GA, Hill PC, Jeffries DJ, Hossain I, Uchendu U, Ameh D, et al. Effect of the introduction of pneumococcal conjugate vaccination on invasive pneumococcal disease in The Gambia: A population-based surveillance study. *Lancet Infect. Dis.* 2016;703–11.
2. von Gottberg A, de Gouveia L, Tempia S, Quan V, Meiring S, von Mollendorf C, et al. Effects of Vaccination on Invasive Pneumococcal Disease in South Africa. *N. Engl. J. Med.* 2014;371:1411-14.
3. Hammit LL, Anthony E, Morpeth SC, Mutuku A, Ojal J, Mturi N, et al. Population effect of 10-valent pneumococcal conjugate vaccine on invasive pneumococcal disease and nasopharyngeal carriage in Kilifi, Kenya. *Manuscr. Prep.* 2017;
4. Transition process - Gavi, the Vaccine Alliance [Internet]. [cited 2017 Jul 10]. Available from: <http://www.gavi.org/support/sustainability/transition-process/>
5. Kenya : Gavi support documents - Proposals, reports, plans, decision letters [Internet]. [cited 2017 Mar 24]. Available from: <http://www.gavi.org/country/kenya/documents/>
6. Ojal J, Flasche S, Hammit LL, Akech D, Kiti MC, Kamau T, et al. Sustained reduction in vaccine-type invasive pneumococcal disease despite waning effects of a catch-up campaign in Kilifi, Kenya: a mathematical model based on pre-vaccination data. *Vaccine.* 2017;35:4561–8.
7. Scott Anthony, Hammit Laura, Karia Boniface, Mutuku Alex, Shariff Shahnaz, Kamau Tatu, et al. Pneumococcal Conjugate Vaccine Impact Study (PCVIS) [Internet]. [cited 2017 Jan 13]. Available from: <http://kemri->

wellcome.org/programme/pcvis-2/

8. Silaba M, Ooko M, Bottomley C, Sande J, Benamore R, Park K, et al. The impact of 10-valent Pneumococcal Conjugate Vaccine on the incidence of radiologically-confirmed pneumonia and on clinically-defined pneumonia among children in Kilifi, Kenya. Manuscr. Prep.

9. Gavi. Pneumococcal Conjugate Vaccine (PCV) 4-dose vial presentations [Internet]. 2017 [cited 2017 Sep 4]. p. 1–9. Available from: <http://www.gavi.org/library/gavi-documents/guidelines-and-forms/pcv-4-dose-vials-faqs/>

10. Moisi JC, Nokes DJ, Gatakaa H, Williams TN, Bauni E, Levine OS, et al. Sensitivity of hospital-based surveillance for severe disease: a geographic information system analysis of access to care in Kilifi district, Kenya. Bull. World Health Organ. 2011;89:102–11.

11. International Monetary Fund [Internet]. [cited 2017 Jun 18]. Available from: https://www.imf.org/external/pubs/ft/weo/2016/01/weodata/weorept.aspx?pr.x=43&pr.y=6&sy=2000&ey=2021&scsm=1&ssd=1&sort=country&ds=.&br=1&c=664&s=NGDP_D&grp=0&a=

12. Murray CJL. Supplementary appendix Comprehensive Systematic Analysis of Global Epidemiology : Definitions , Methods , Simplification of DALYs , and Comparative Results from the Global Burden of Disease Study 2010. Lancet. 2012;9859.

13. Salomon JA, Haagsma JA, Davis A, Noordhout CM De, Polinder S, Havelaar AH, et al. Disability weights for the Global Burden of Disease 2013 study. Lancet Glob. Heal. Salomon et al. Open Access article distributed under the terms of CC BY-NC-ND; 2015;3:712–23.

14. GHO | By category | Life tables by country - Kenya [Internet]. WHO. World Health Organization; [cited 2017 Jul 11]. Available from:
<http://apps.who.int/gho/data/?theme=main&vid=60850>
15. Ojal J, Hammitt LL, Gaitho J, Scott JAG, Goldblatt D. Pneumococcal conjugate vaccine induced IgG and nasopharyngeal carriage of pneumococci: Hyporesponsiveness and immune correlates of protection for carriage. *Vaccine*. 2017;35:4652–7.
16. Countries approved for support - Gavi, the Vaccine Alliance [Internet]. 2014 [cited 2015 Jan 20]. Available from:
<http://www.gavi.org/results/countries-approved-for-support/>
17. Sachs JD. Macroeconomics and Health: Investing in Health for Economic Development: Report of the Commission on Macroeconomics and Health. *Nat. Med*. 2001;8:1–200.
18. Marseille E, Larson B, Kazi DS, Kahn JG, Rosen S. Thresholds for the cost – effectiveness of interventions: alternative approaches. *Bull. World Health Organ*. 2015;93:118–24.
19. van Hoek AJ, Ngama M, Ismail A, Chuma J, Cheburet S, Mutonga D, et al. A Cost Effectiveness and Capacity Analysis for the Introduction of Universal Rotavirus Vaccination in Kenya: Comparison between Rotarix and RotaTeq Vaccines. *PLoS One*. 2012;7.
20. Oloo Akumu A. Economic evaluation of delivering Haemophilus influenzae type b vaccine in routine immunization services in Kenya. *Bull. World Health Organ*. 2007;85:511–8.
21. Kenya Ministry of Health. National and County Health Budget Analysis FY2015/2016. Nairobi; 2016.

22. The Global Alliance for Vaccines and Immunisation. Country co-financing information sheet, Kenya. 2017.
23. Burki TK han. Pricing of pneumococcal conjugate vaccine challenged. *Lancet. Respir. Med.* Elsevier Ltd; 2015;3:427.
24. Flasche S, Van Hoek AJ, Goldblatt D, Edmunds WJ, O'Brien KL, Scott JAG, et al. The Potential for Reducing the Number of Pneumococcal Conjugate Vaccine Doses While Sustaining Herd Immunity in High-Income Countries. *PLoS Med.* 2015;12:1–5.
25. Källander K, Hildenwall H, Waiswa P, Galiwango E, Peterson S, Pariyob G. Delayed care seeking for fatal pneumonia in children aged under five years in Uganda: A case-series study. *Bull. World Health Organ.* 2008;86:332–8.
26. Edmond K, Clark A, Korczak VS, Sanderson C, Griffiths UK, Rudan I. Global and regional risk of disabling sequelae from bacterial meningitis: A systematic review and meta-analysis. *Lancet Infect. Dis.* 2010;10:317–28.
27. Berkley J a, Lowe BS, Mwangi I, Williams T, Bauni E, Mwarumba S, et al. Bacteremia among children admitted to a rural hospital in Kenya. *N. Engl. J. Med.* 2005;352:39–47.
28. Ayieko P, Griffiths UK, Ndiritu M, Moisi J, Mugoya IK, Kamau T, et al. Assessment of health benefits and cost-effectiveness of 10-valent and 13-valent pneumococcal conjugate vaccination in Kenyan children. *PLoS One.* 2013;8:e67324.
29. Gavi welcomes new record low price for pneumococcal vaccine [Internet]. [cited 2017 Mar 24]. Available from: <http://www.gavi.org/library/news/statements/2016/gavi-welcomes-new-record-low-price-for-pneumococcal-vaccine/>

30. Gavi. Vaccine co-financing [Internet]. 2015 [cited 2017 Sep 4]. p. 1–4.
Available from: <http://www.gavi.org/support/sustainability/faqs-about-co-financing/>
31. Auto-Disable (AD) and Re-Use Prevention (RUP) Syringes and Safety Boxes - current price data [Internet]. Supplies Logist. UNICEF. 2016 [cited 2017 Jul 28]. Available from: https://www.unicef.org/supply/index_62309.html
32. Mvundura M, Lorenson K, Chweya A, Kigadye R, Bartholomew K, Makame M, et al. Estimating the costs of the vaccine supply chain and service delivery for selected districts in Kenya and Tanzania. *Vaccine*. Elsevier Ltd; 2015;33:2697–703.
33. Parmar D, Baruwa EM, Zuber P, Kone S. Impact of wastage on single and multi-dose vaccine vials: Implications for introducing pneumococcal vaccines in developing countries. *Hum. Vaccin*. 2010;6:270–8.
34. Ayieko P, Akumu AO, Griffiths UK, English M. The economic burden of inpatient paediatric care in Kenya: household and provider costs for treatment of pneumonia, malaria and meningitis. *Cost Eff. Resour. Alloc*. 2009;7:3.
35. Larson B, Amin A, Noor AM, Zurovac D, Snow RW. The cost of uncomplicated childhood fevers to Kenyan households: implications for reaching international access targets. *BMC Public Health*. 2006;6:314.

Table 1: Economic and health parameters varied in sensitivity analysis

Parameter	Point estimate	Statistical distribution	Source
Access to care proportions for pneumococcal diseases			
Hospitalised sepsis, bacteraemic and non-bacteraemic cases	55%	Beta (55,45)	[10]
Hospitalized meningitis cases	70%	Beta (70,30)	[10]
Unhospitalised IPD and non-bacteraemic cases treated as outpatient	63%	Beta (63,37)	[25]
Health outcomes			
Proportion of meningitis cases developing sequelae	25%	Beta (25,75)	[26]
CFR with hospital care			
Sepsis, bacteraemic and meningitis: Children (<15 years)	19%	Beta (19,81)	KCH
Sepsis, bacteraemic and meningitis: Adults (>=15 years)	46%	Beta (46,54)	KCH
Non-bacteraemic pneumonia	5.7%	Beta (6,94)	[27]
CFR without hospital care			
Meningitis	97%	Beta (97,3)	[28]
Sepsis and bacteraemic pneumonia	50%	Beta (4,4)	[28]
Non-bacteraemic pneumonia	12%	Beta (12,88)	[28]
Vaccination costs (US\$)			
Vaccine price per dose	\$0.21-\$3.05 (Table S2)	Fixed	[4,29,30]
Safety boxes	\$0.46	Fixed	[31]
AD syringes	\$0.045	Fixed	[31]
Reconstruction syringes	\$0.052	Fixed	[31]
Vaccine delivery cost per dose	\$1.42	Gamma (4,0.4)	[32]
Syringe wastage	5%	Fixed	[28]
Vaccine wastage	15%	Fixed	[9,28,33]
Treatment costs (US\$)			
With hospital care			
Meningitis	\$357.74	Gamma (4,97)	[34]
Sepsis, bacteraemic and non-bacteraemic pneumonia	\$74.64	Gamma (4,19)	[34]
With outpatient care (All four syndromes)	\$2.74	Gamma(4,0.75)	[35]
Without hospital care (All four syndromes)	\$1.15	Gamma (4,0.3)	[35]

Table 2: Estimated costs and cost-effectiveness ratios for different scenarios

Scenario	Average annual cost Over 2022-2032, millions of US\$ (95% PI)	Cost per case averted in 2032, US\$ (95% PI)	Cost per death averted in 2032, US\$ (95% PI)	Cost per DALY Averted in 2032, US\$ (95% PI)
Stopping vaccination in year 2022	3.3 (1.3 – 7.1)	Ref.	Ref.	Ref.
Continuing vaccination	18.9 (13.2 – 29.4)	878.4 (566.9- 1446.3)	6386.8 (3819.0 – 11250.1)	142.7(85.1 – 252.4)
Continuing vaccination (discounting costs only)	18.9 (13.2 – 29.4)	531.4 (343.0 – 875.0)	3864.1 (2310.6 – 6806.5)	67.5 (40.1 – 120.1)

Supplementary table S1: Invasive Pneumococcal disease (IPD) separation in to meningitis, pneumococcal bacteraemic pneumonia and sepsis. IPD cases are obtained from hospitalized cases at the Kilifi County hospital among residents of the Kilifi Health and Demographic Surveillance System for the period 1999-2016 (<15) for children and 2007-2016 for adults (>=15).

Age category	Pneumococcal Meningitis ^a		Pneumococcal Bacteraemic Pneumonia ^b		Pneumococcal Sepsis ^c	
	n	%	n	%	n	%
<1	52	28.0	85	45.7	49	26.3
1-5	32	11.3	126	44.4	126	44.4
6-14	39	29.8	47	35.9	45	34.4
15-20	1	33.3	0	0.0	2	66.7
21-49	11	29.7	3	8.1	23	62.2
50+	3	11.5	2	7.7	21	80.8

^a Isolation of *S. pneumoniae* from cerebrospinal fluid (CSF) or isolation of *S. pneumoniae* from blood, accompanied by a CSF white blood cell count of 50×10^6 cells/L or greater or a ratio of CSF glucose to plasma glucose less than 0.1

^b IPD with no pneumococcal meningitis but with WHO severe or very severe pneumonia.

^c IPD not meeting any of the above definitions of pneumococcal meningitis and bacteraemic pneumococcal pneumonia.

Supplementary table S2: Vaccine price per dose paid by Kenya in each year

Gavi transition phase	Year	Vaccine price per dose (US\$)
Preparatory transition phase: Contribution to price per dose increases by 15% annually	2017	0.21
	2018	0.24
	2019	0.28
	2020	0.31
	2021	0.37
Accelerated transition phase: Contribution starts at an additional 20% of the difference between the projected price of the vaccine in the year a country enters fully self-financing phase and the co-financing amount per dose paid in the preceding year, and increases linearly over four years to reach the projected price.	2022	0.91
	2023	1.34
	2024	1.77
	2025	2.20
	2026	2.63
Fully self-financing: Country pays the full vaccine price	2027 - 2032	3.05*

*This is the price assumed when Kenya enters the fully self-financing phase. It is the current price of PCV10. The actual price then might be lower since prices are generally expected to go down, but there are currently no projections from Gavi.

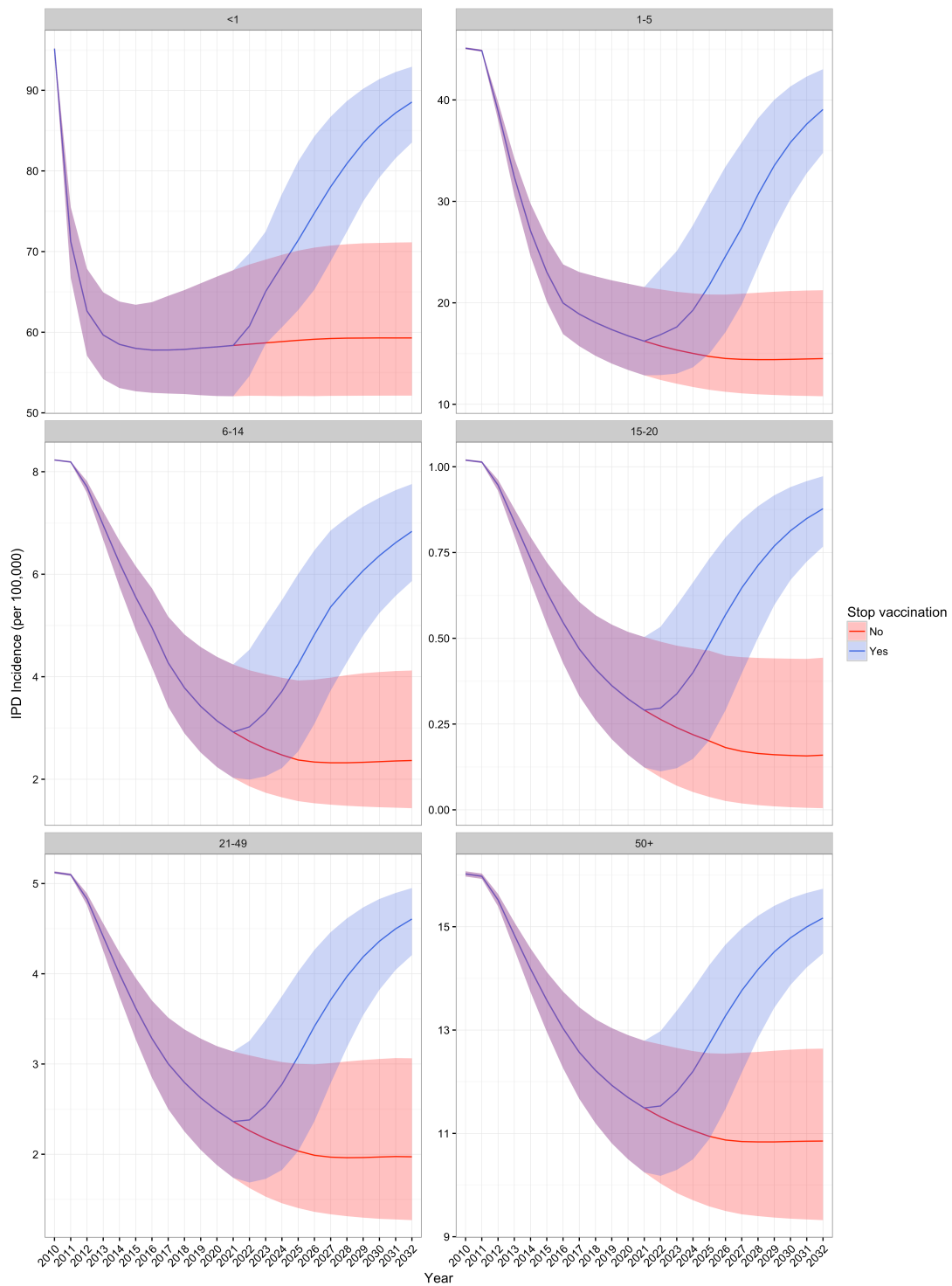

Figure 1: Invasive pneumococcal disease (IPD) impact by age group
 Predicted incidence of IPD when vaccination is continued in 2022 (red line), its 95% prediction interval (light-red shade), and when vaccination is stopped (blue line, with 95% prediction interval shown in light-blue shade) over time since vaccine introduction in Kenya in 2010.

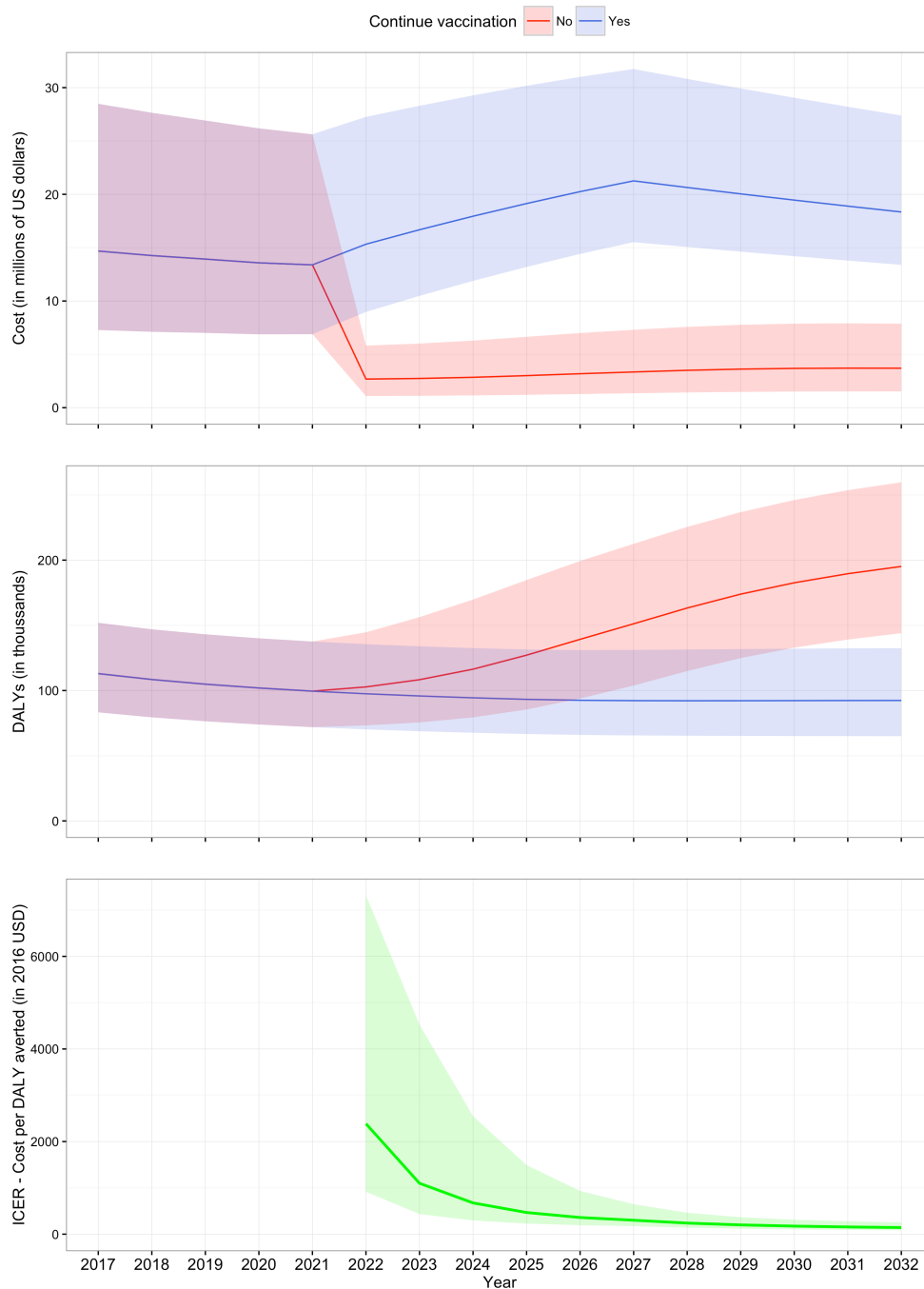
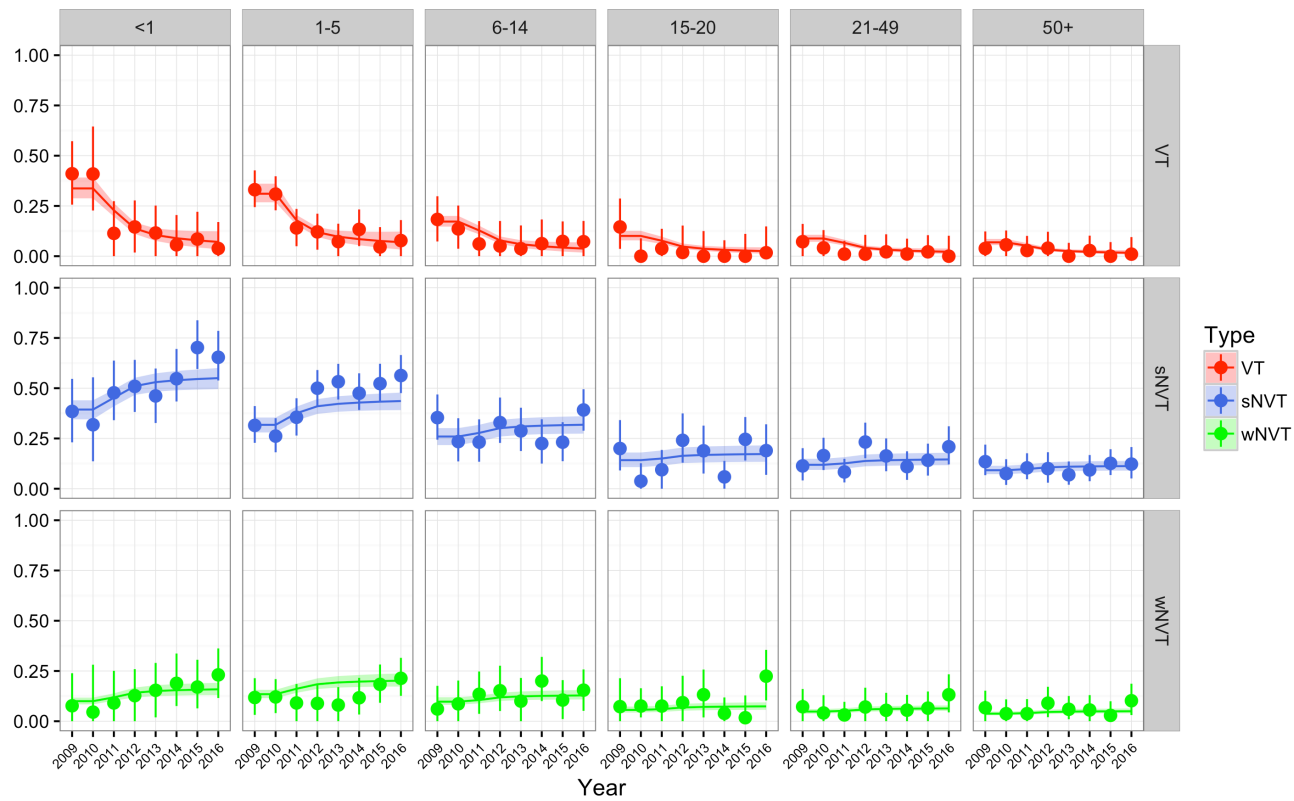

Figure 2: Costs, DALYs and incremental cost-effectiveness ratios (ICERs) by year

The topmost panel shows the cost of treatment and vaccination in each year (blue line with light-blue shade for 95% PI) when vaccination is continued, and the cost of treatment in each year when vaccination (red line, with light-red shade for 95% PI) is discontinued in 2022. The middle panel shows the corresponding DALYs gained in each year. The bottom panel shows the ICER (y-axis), incremental (continuing vaccination over stopping vaccination) cost per DALY averted (green line) and its 95% prediction interval (light-green shade) in each year (x-axis).



Supplementary Figure 1: Model fit to carriage data

Observed (circular dots with 95% credible intervals shown by spikes) and predicted (lines with 95% predictive intervals shown by shaded areas) carriage prevalence of vaccine-serotypes (VT), shown in red, strong non-vaccine serotypes (sNVT), shown in blue, and weak non-vaccine serotypes (wNVT), shown in lime green, over time. The age groups are labelled at the panel title.

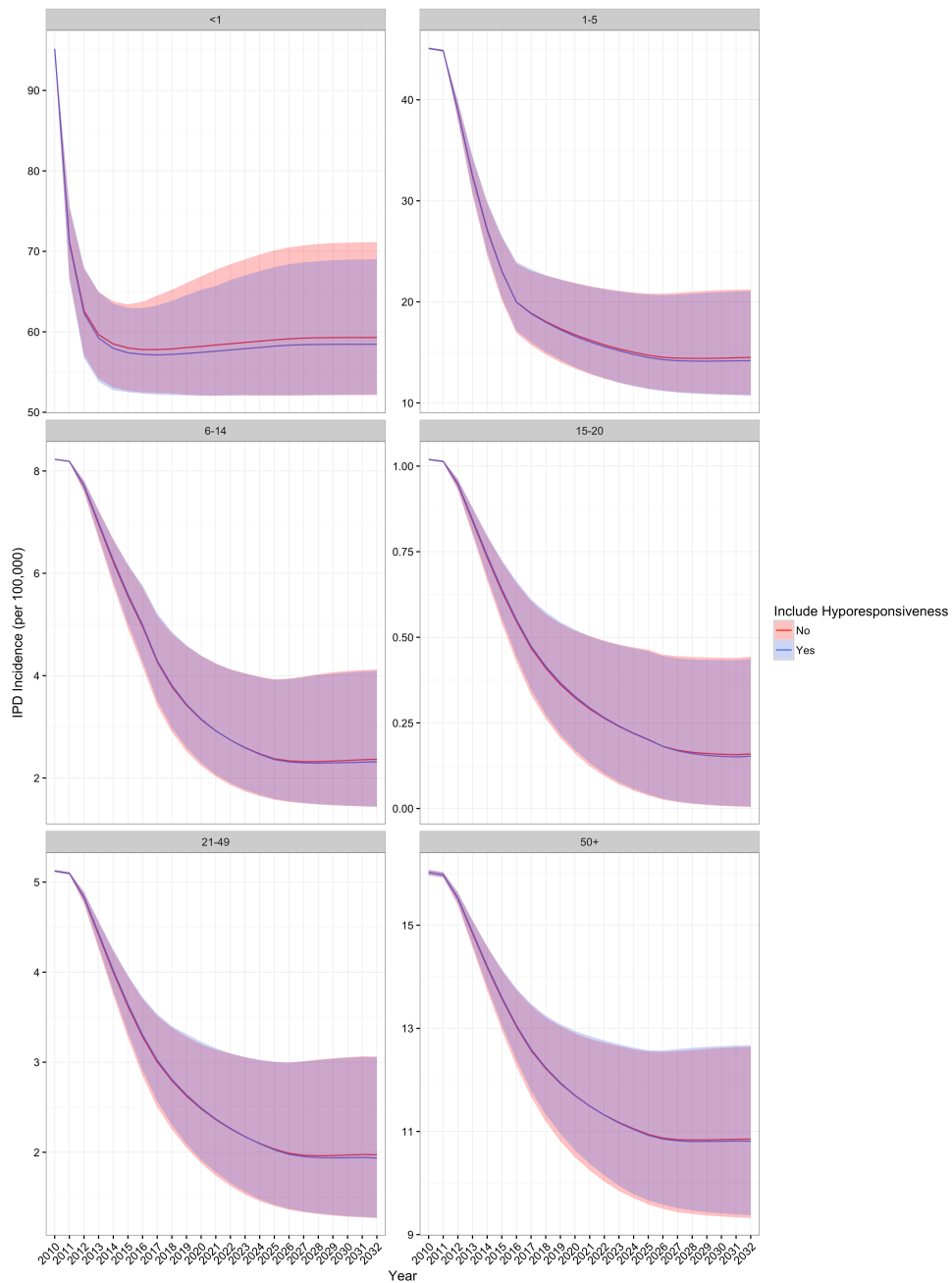

Supplementary Figure 2: IPD projection with and without hyporesponsiveness by age group

Predicted incidence of IPD when hyporesponsiveness is ignored in the carriage model (red line with 95% prediction interval shown in light-red shade, and when hyporesponsiveness is allowed for in the model structure (blue line, with 95% prediction interval shown in light-blue shade) over time since vaccine introduction in Kenya. Age groups are labelled on the panel titles.

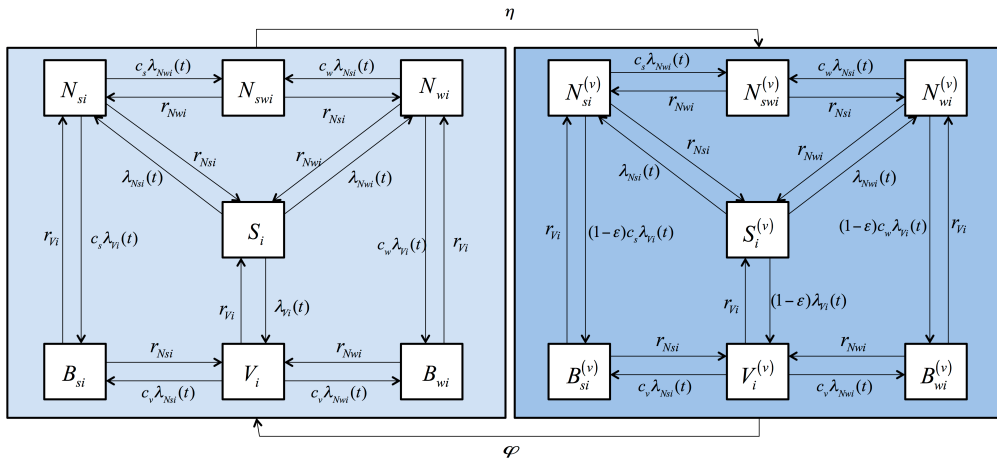

Supplementary Figure 3: Model structure flow diagram

The epidemiological states include individuals that are susceptible (non-carrying), S ; carry a vaccine serotype, V ; carry a weak non-vaccine serotype, N_w ; carry a strong non-vaccine serotype, N_s ; carry simultaneously a weak and a strong non-vaccine serotype, N_{sw} ; carry simultaneously a vaccine serotype and a weak non-vaccine serotype, B_w ; or carry simultaneously a vaccine serotype and a strong non-vaccine serotype, B_s (see text). Once vaccinated, the individual moves to one of the corresponding states, $(S^{(v)}, V^{(v)}, N_w^{(v)}, N_s^{(v)}, B_w^{(v)}$ and $B_s^{(v)})$. The acquisition rates from the single to multiple serotype carriage states are reduced by competition parameters denoted by c with two subscripts; the first denoting the serotype group (v, s and w , for VT, strong NVT and weak NVT respectively) of the resident serotypes and the second denoting the age-group. The competition parameters have two sets of values, one for age group <6 and another for age group ≥ 6 years (see Appendix). The age-group specific VT, weak NVT and strong NVT clearance rates are denoted by r_{Vi} , r_{Nwi} and r_{Nsi} , respectively. In addition to the transitions between the 14 epidemiological states as shown in the Figure, individuals die from any states at age-specific death rates and new individuals are born into the completely susceptible state.

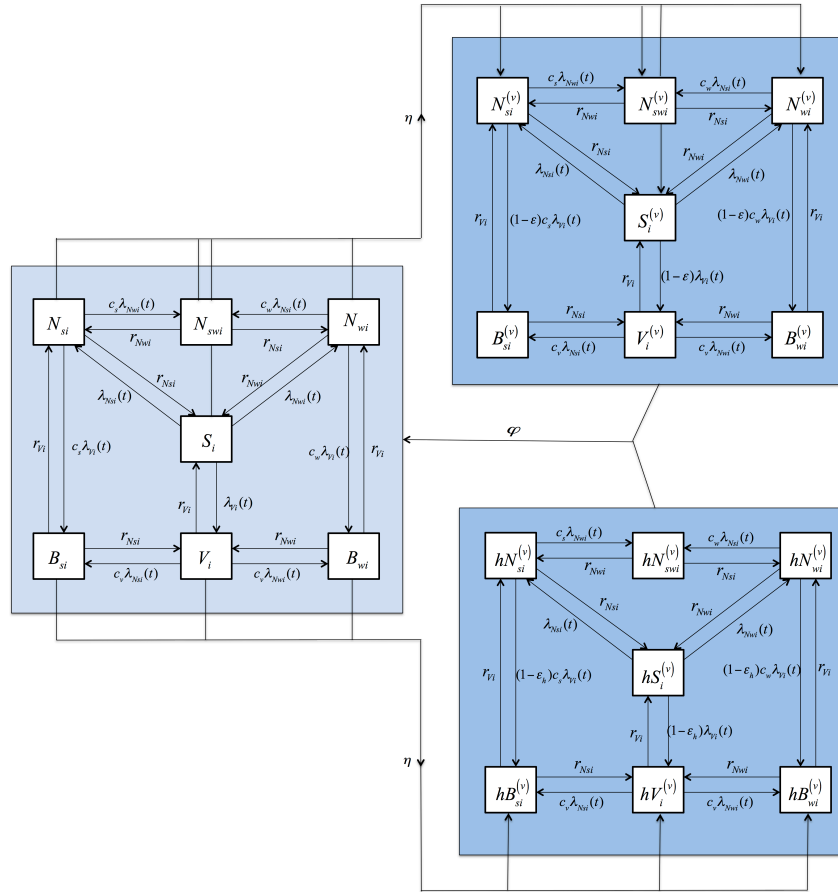

Supplementary Figure 4: Model structure flow diagram including hypo-responsiveness

The epidemiological states include individuals that are susceptible (non-carrying), S ; carry a vaccine serotype, V ; carry a weak non-vaccine serotype, N_w ; carry a strong non-vaccine serotype, N_s ; carry simultaneously a weak and a strong non-vaccine serotype, N_{sw} ; carry simultaneously a vaccine serotype and a weak non-vaccine serotype, B_w ; or carry simultaneously a vaccine serotype and a strong non-vaccine serotype, B_s (see text). Once vaccinated, individuals not carrying vaccine serotypes move to the corresponding states ($S^{(v)}, N_w^{(v)}, N_s^{(v)}, N_{sw}^{(v)}$) while those carrying vaccine serotypes ($V, B_w^{(v)}, B_s^{(v)}$) move to the corresponding hypo-response-associated states ($hV, hB_w^{(v)}, hB_s^{(v)}$). The acquisition rates from the single to multiple serotype carriage states are reduced by competition parameters denoted by c with two subscripts; the first denoting the serotype group (v, s and w , for VT, strong NVT and weak NVT respectively) of the resident serotypes and the second denoting the age-group. The competition parameters have two sets of values, one for age group <6 and another for age group ≥ 6 years (see Appendix). The age-group specific VT, weak NVT and strong NVT clearance rates are denoted by r_{Vi}, r_{Nwi} and r_{Nsi} , respectively. In addition to the transitions between the 21 epidemiological states as shown in the Figure, individuals die from any states at age-specific death rates and new individuals are born into the completely susceptible state.

Appendix: Model structure and parameters estimates

Model structure

A more detailed description of the model and the likelihood function is presented in¹. The brief description provided in this appendix is to help in the understanding of the notation used, without necessarily referring to¹. The model is compartmental, age-structured and dynamic. Compartments are defined according to pneumococcal carriage states (Supplementary Figure 3). It has a Susceptible-Infected-Susceptible (SIS) structure for three serotype groups: the PCV10 serotypes, strong NVT and weak NVT.

At any point in time, an unvaccinated individual can be susceptible (non-carrying) in state S ; carry a VT, V ; carry a weak NVT, N_w ; carry a strong NVT, N_s ; carry simultaneously a weak and strong NVT, N_{sw} ; carry simultaneously a VT and weak NVT, B_w ; or carry simultaneously a VT and a strong NVT, B_s . Once vaccinated, the individual moves to one of the corresponding states ($S^{(v)}, V^{(v)}, N_w^{(v)}, N_s^{(v)}, N_{sw}^{(v)}, B_w^{(v)}, B_s^{(v)}$). We also fitted a model in which the efficacy of the vaccine on carriage acquisition is reduced due to prevailing carriage at the point of vaccination (hyporesponsiveness) is considered. Under this model, upon vaccination, individuals not carrying vaccine serotypes move to the corresponding states ($S^{(v)}, N_w^{(v)}, N_s^{(v)}, N_{sw}^{(v)}$) while those carrying vaccine serotypes ($V, B_w^{(v)}, B_s^{(v)}$) move to the corresponding hyporesponse-related states ($hV, hB_w^{(v)}, hB_s^{(v)}$) (Supplementary Figure 4).

Parameterisation

A susceptible unvaccinated individual in age group i becomes colonised with VTs, strong NVTs or weak NVTs at age-group-specific time-dependent rates (forces of infection) denoted by $\lambda_{Vi}(t)$, $\lambda_{Nsi}(t)$ and $\lambda_{Nwi}(t)$, respectively. The forces of infection were expressed as functions of the social mixing matrix and age-group specific factors (q_i) that scale the rate of social contacts into infectious contacts. Due to competition between serotypes in colonising the nasopharynx, the acquisition rate of a secondary serotype is lower than the acquisition rate of that serotype in a completely susceptible individual. Three competition parameters, c_{v0} , c_{w0} and c_{s0} , represent the fraction by which acquisition rates of secondary serotypes are reduced in <6 year olds infected with VTs, weak NVTs and strong NVTs, respectively. Two competition parameters, $c_{vw} = c_v = c_w$ and c_s , were used for individuals aged ≥ 6 years infected with VTs/weak NVTs and strong NVTs, respectively. In the vaccinated compartments the rate of acquisition of VTs are reduced by the vaccine efficacy against carriage acquisition denoted ε , or ε_h according to whether the compartment is associated with hyporesponsiveness.

The Metropolis-Hastings algorithm was used to draw samples from the posterior distributions of the parameters. Uniform priors in the range 0-1 were used for competition parameters and the social contact scaling parameters (q_i). For the vaccine efficacy parameters we used a normal prior centered around 50% with 95% uncertainty interval of 40-60%. 50,000 adaptive MCMC iterations were used. After a burn-in of 25,000 was discarded the remaining

stationary samples were thinned to 5000 to estimate the posterior distribution. Convergence was assessed graphically, by observing was no negative or positive trend (zero gradient) in the chain, and by using Geweke diagnostic to check if a chain was stationary. The thinned posterior samples of the parameters were summarised to obtain point estimates (posterior mean) and probability (credibility) intervals. The parameter estimates are shown in Table A1.

¹ Ojal J, Flasche S, Hammitt LL, Akech D, Kiti MC, Kamau T, et al. *Sustained reduction in vaccine-type invasive pneumococcal disease despite waning effects of a catch-up campaign in Kilifi, Kenya: a mathematical model based on pre-vaccination data*. *Vaccine*. 2017;35:4561–8.

Table A1. Estimated parameters of the dynamic transmission models

Parameter	Estimate (95% Credible Interval)	Estimate accounting for hyporesponsiveness (95% Credible Interval)
Competition parameters	$c_{S0} = 0.42$ (0.24, 0.62) $c_{W0} = 0.73$ (0.44, 0.97) $c_{V0} = 0.44$ (0.25, 0.70) $c_S = 0.11$ (0.01, 0.40) $c_{vw} = c_v = c_w = 0.70$ (0.30, 0.98)	$c_{S0} = 0.41$ (0.25, 0.59) $c_{W0} = 0.70$ (0.43, 0.97) $c_{V0} = 0.46$ (0.27, 0.70) $c_S = 0.10$ (0.01, 0.30) $c_{vw} = c_v = c_w = 0.66$ (0.24, 0.98)
Probability of infection per 100 contacts	$q_1 = 0.14$ (0.11, 0.19) $q_2 = 0.45$ (0.38, 0.55) $q_3 = 0.30$ (0.26, 0.35) $q_4 = 0.08$ (0.06, 0.11) $q_5 = 0.16$ (0.13, 0.19) $q_6 = 0.06$ (0.05, 0.07)	$q_1 = 0.14$ (0.11, 0.19) $q_2 = 0.45$ (0.39, 0.54) $q_3 = 0.30$ (0.26, 0.35) $q_4 = 0.08$ (0.06, 0.10) $q_5 = 0.16$ (0.13, 0.19) $q_6 = 0.06$ (0.05, 0.07)
Vaccine efficacy against carriage	$\varepsilon = 0.59$ (0.49, 0.68)	$\varepsilon = 0.58$ (0.47, 0.68)
Vaccine efficacy against carriage for VT carriers (hyporesponsiveness)	N/A	$\varepsilon_h = 0.54$ (0.40, 0.68)

Chapter 6: General discussion

Kenya introduced PCV10 in 2011 in a 3+0 schedule in which infants are vaccinated at 6, 10 and 14 weeks of age. In Kilifi, a town in coastal Kenya, the introduction was accompanied by a catch-up campaign among children <5 years, which achieved coverage of 65%. Data from KHDSS, the demographic surveillance site in Kilifi, has shown a significant drop in both vaccine-serotype carriage and vaccine-serotype IPD. Carriage of vaccine serotypes was reduced by two-thirds both in children younger than 5 years and in older individuals [1,2]. In children <5 years, the incidence of vaccine-serotype IPD fell by 92% while the overall IPD decreased by 68% in the post vaccination period (2012-2016) [3].

1.1 Summary of findings

On top of this epidemiological background, I developed a transmission model fitted to pre-vaccination (2009-2010) carriage data. I validated the model predictions against post-vaccination carriage data (2011-2015) and showed that the model closely predicted the observed magnitude and timing of serotype replacement carriage. This illustrates the utility of transmission dynamic modelling in predicting disease changes from carriage data in the absence of disease data, as has been observed with several other models of pneumococcal transmission. However, most of the previous pneumococcal carriage models in literature have consolidated non-vaccine serotypes (NVT)

in to a single group. In the model I have developed, some of the heterogeneity in bacterial fitness parameters, such as susceptibility to the competition that exist across individual serotypes, has been accounted for by splitting NVT into weak and strong groups. Differentiating the non-vaccine serotypes into two groups led to different predictions for weak and strong NVT and these predictions matched well with the observed data.

A concern of the rapid and substantial impact of PCV10 in Kilifi was its sustainability once the effects of the catch-up campaign have waned. In the model presented, the current schedule was predicted to be sufficient to limit vaccine-type pneumococcal carriage to current levels even after incorporating demographic change; however, it is unlikely to lead to the elimination of vaccine serotypes [4].

If newborn infants are protected naturally in the first few months of life by maternally-derived serotype-specific antibodies and if the levels of these antibodies in mothers are maintained by repeated re-infection, then one of the consequences of introducing PCV10 into a population will be a reduction in the protection afforded to young infants through passive maternal protection; this comes about simply because the PCV10 programme will reduce transmission in the population, and reduce re-stimulation of mothers. However, in most settings this effect is likely to be amply compensated for by the reduced exposure of young infants to the vaccine serotypes. In Kilifi, unlike most developed country settings, transmission of vaccine types was not completely eliminated and so young infants remain at risk of infection and

disease. Also, a transmission model ignoring the effect serotype-specific maternal antibody protection would overestimate the impact of vaccination since that effect would be wholly, and wrongly, attributed to the herd protection from vaccination.

In the analysis of the protective effect of maternally-derived antibodies against carriage acquisition I found a significant association between carriage acquisition and several anti-protein antibodies but only a limited protective effect of maternally-derived anti-capsular antibodies and only at high concentrations [5]. The effect of anti-protein antibodies to a particular pneumococcal protein, whether in decreasing or increasing the risk of carriage acquisition, is not serotype-specific. I observed a limited protective effect of maternally-derived anti-capsular antibodies to five common serotypes (6A, 6B, 14, 19F and 23F) in the pre-vaccination period in Kenya at high concentrations, but those concentrations were achieved by only 3% of the newborn population [5]. The limited applicability of these findings in the natural setting justifies our decision to omit protection from maternally-derived anti-capsular antibodies in transmission models. In addition, I predict that a resurgence of VT disease in young infants as a result of reduced capsular protection from maternally-derived antibodies is unlikely.

Despite a significant reduction in VT carriage following PCV10 introduction we observed sustained transmission of VT serotypes within the surveillance population at KHDSS. If children are vaccinated while carrying a VT serotype the vaccine will have a reduced efficacy, designated as 'hyporesponsiveness'.

One would predict that, as VT carriage prevalence is reduced by the maturation of the PCV10 programme there would be a positive feedback loop, with increasing vaccine efficacy caused by a declining probability that the vaccine is given to a VT serotype carrier. If the impact of this hyporesponsiveness turned out to be immunologically significant, then, with time there should be improved protection from VT carriage that cannot be attributed to direct and herd protection alone and hence the issue of residual VT carriage may resolve itself more quickly than expected.

My analyses of the link between carriage and vaccine responses confirmed hyporesponsiveness in both infants and toddlers [6]. Hyporesponsiveness was quantified as the difference in geometric mean antibody concentrations, observed at a specific point after vaccination, between carriers and non-carriers at the time of vaccination. As we found no valid estimate of the correlates of protection against carriage acquisition, the clinical implication of the observed hyporesponsiveness, i.e. the percentage reduction of vaccine efficacy against carriage acquisition, could not be quantified. Therefore, it was not possible to account for hyporesponsiveness by reducing vaccine efficacy among VT carriers in the transmission model. Instead, the reduction in efficacy was estimated by fitting a model that incorporated hyporesponsiveness in its structure to age and serotype group dependent carriage data (research paper 4). From the fit of this model, VT carriers were estimated to have a vaccine efficacy against carriage that was 4% lower than that among non-VT carriers. This very small reduction in efficacy may be a function of the relatively short period of observation post-vaccination, during

which the effect of hyporesponsiveness on carriage may not yet have had sufficient opportunity to accelerate carriage clearance in the population.

Nonetheless, in comparison with a model structure that ignored hyporesponsiveness, the model that included hyporesponsiveness did not significantly improve on the predictions for carriage or disease (research paper 4). It is therefore unlikely that the effect of hyporesponsiveness is of epidemiological relevance for the vaccination programme in Kenya.

Most countries have now introduced PCV in to their childhood immunisation programmes. Because PCVs are expensive, the majority of developing countries were only able to introduce these vaccines with substantial financial support from Gavi, the Vaccine Alliance. However, these countries will be expected to transition out of Gavi support and begin to pay the full cost of their PCV vaccination programmes as their economies grow. Countries approaching the 'transition threshold' in economic development will need to assess the cost-effectiveness and affordability of sustaining their PCV programmes to guide policy decisions concerning these programmes.

Kenya's contribution to the vaccine price will increase rapidly from US\$0.91 to US\$3.05 per dose over the five years from 2022-2027. I show that sustaining PCV10 vaccination is cost-effective by conventional criteria in Kenya but it will present major challenges to affordability for the Kenya Government.

1.2 Limitations

Natural immunity can be acquired after exposure to pneumococcal carriage and can reduce the duration of carriage in subsequent episodes [7,8]. This means that those who have more prior experience (and are therefore generally older) will be less susceptible to carriage acquisition. However, natural immunity was not explicitly incorporated in the structure of the transmission model. Some of the protection derived from natural exposure would be captured in the age-group dependent risk of pneumococcal acquisition estimated in the model. Nonetheless, not explicitly incorporating natural immunity in the model might lead to an overestimate of the impact of vaccination, especially in the early years of vaccine introduction.

The model did not fully account for the heterogeneity in fitness characteristics across individual serotypes because it relied on broad serotypes groups. There was no formal validation of the optimal number of NVT groups. The decision to use two NVT groups was conservative in order to avoid potential difficulties in model fitting in a highly-compartmentalised model. A model comparison process with varying number of groups of VT and NVT could help in choosing the optimal number of serotype groupings. The grouping of serotypes may also artificially promote their co-existence in the model because it artificially reduces serotype-specific fitness differences.

It is an assumption of the model process that the case-to-carrier ratios remain constant across the whole period of observation. These, were estimated using pre-vaccination data and used to translate changes in carriage into changes

in disease incidence. However, there is some evidence to suggest that vaccine driven selection pressure can result in genetic shifts in the pneumococcal population and this may bring about serotype switching [9–11]. In fact, serotype switching has been documented even in the absence of vaccination [12]. Because the capsule is a determinant of virulence including the invasive capacity, serotype switching may lead to a change in the case-to-carrier ratio. For instance, it has been shown in the USA introduction of PCV7 led to genetic shifts such that strains carrying vaccine serotype 4 adopted the capsular genes of a 19A strain – which was non-PCV7 serotype [10]. The original serotype 4 strain carried virulence proteins that were likely to give rise to invasions, therefore, the case-to-carrier ratio for 19A probably increased across the vaccine eras as it incorporated strains of serotype 4 origin. If case-to-carrier ratios of non-vaccine serotypes generally become higher due to vaccine escape recombinants, then the future incidence of non-vaccine serotype IPD would be under predicted by the model. In Kenya, pneumococci collected pre-PCV10 have been genotyped [13], genotyping post-vaccination isolates will determine whether there is capsular switching linked to vaccination.

The model was fitted to data where only a single serotype was recorded per nasopharyngeal sample. Since the model had states in which individuals are carrying two serotypes simultaneously, fitting the model to the data was made possible through an assumption that in a doubly-colonised individual either of the two colonising serotypes was detected with equal probability. This implies that the relative abundance of the two serotypes were equal, which might not

be true. Genotypic laboratory methods that can measure the relative abundance of pneumococcal serotypes in a nasopharyngeal sample are now developed [14], and will be input in future transmission models. The mathematical model I developed can be fitted to multiple serotypes carriage data without structural modification, assuming that carriage of more than two serotypes is negligible. However, it is not yet clear if the density of carriage of serotypes is correlated with its ability to transmit, a dynamic that future pneumococcal transmission models might have to consider.

The principal limitation of the study of the effect of maternally-derived antibodies on the rate of acquisition of carriage in newborns was its observational design; the absence of a randomised intervention means it is difficult to control completely for confounding. Environmental factors can predispose mothers to increased carriage and this can lead to higher antibody concentrations which will be passively transferred to their newborns. Since the newborn is also brought up in the same high transmission environment, it might be estimated that higher antibody concentrations are associated with carriage if confounding by environmental factors cannot be adequately controlled for in the analysis. My analysis adjusted for household level risk factors for carriage such as: type of fuel used for cooking, number of siblings aged <10 years, number of other children aged <10 years, number of adults, number of smokers and number of carers. However, there could be residual confounding attributable to additional environmental factors beyond those already adjusted for. For instance, a poor social-economic status has been associated with increased carriage [15]. Incomplete adjustment for

confounding in the analysis could be overcome by testing the phenomenon in an experimental design using nasopharyngeal challenge studies in animal or human models [16–18]. Our lack of understanding of the primary biological role of different proteins limited the interpretation of some associations between high levels of anti-protein antibody and high levels of acquisition.

In the cost-effectiveness analysis, I focused on a single dichotomous decision - continuing with PCV10 vaccination versus discontinuing PCV in 2022. These are not the only options available for Kenya. For example, Kenya may choose to introduce a novel 10-valent PCV which is currently in clinical development by the Serum Institute of India and is aimed at a price of \$2.00 per dose [19]. Alternative vaccination schedules, for example using a booster dose in the second year of life with a reduced number of doses in infancy, may enhance the cost-effectiveness of PCV10 by further reducing VT carriage and disease and/or vaccination costs. However, this was not assessed within the current scope of the PhD. Furthermore, future cost-effectiveness models that incorporate the impact of vaccines on economic development [20], and not just the health loss in form of DALYs, may be more persuasive to governments and societies. This approach has not been taken in the current work though it may lead to a revision of the affordability of vaccines by government – the principal challenge identified in the CEA study.

Lastly, the predictions of the impact of PCV10 vaccination in this study can only be generalised to countries with similar pre-vaccination epidemiology as Kenya. This means that they should have similar carriage and IPD patterns,

similar transmission dynamics, similar vaccine serotype coverage and similar vaccination uptake. Nonetheless, the model can be re-parameterised with data from other settings and used to predict carriage and disease impact in those settings.

1.3 Future work

In African countries that have been using PCV for at least 5 years, vaccine serotypes continue to circulate at relatively higher levels [1,21] than in developed countries where carriage prevalence is now usually <2% [22]. Among infants and children aged <5 years in Kilifi, Kenya, the prevalence of PCV10 serotypes in carriage in 2016 is estimated from a cross-sectional carriage study at about 8% and 6%, respectively [3]. It is therefore necessary to maximise herd protection by eliminating VT circulation.

There are a number of factors that could explain the high residual VT carriage in children in these African countries. The first factor is a higher force of infection in African children. The population density, the effective contact patterns and environmental factors such as poor hygienic conditions can influence the force of infection. A high population density increases the frequency of contacts between individuals and consequently intensifies the force of infection. The population density in Africa (40 persons/km²) countries is higher than in developed countries (25 persons/km²) [23]. In addition, families in rural and semi-urban areas are organised into households with sizes that are much larger on average than those in developed countries [24];

this increases the frequency of close interactions. Poor hygienic conditions increase the transmission probability and therefore the force of infection.

Given this higher force of infection, the coverage of routine vaccination may not be sufficient to eliminate VT transmission; one solution therefore, might be to raise vaccine coverage to almost 100%. In The Gambia, the coverage of at least two doses of PCV13 in children aged 2-23 months plateaued at 73% in 2013 following replacement of PCV7 with PCV13 in 2011 [25]. Carriage prevalence of PCV13 serotypes in infants was 18.3% in 2013 [21], data on carriage in more recent years has not been published yet. In Kenya, the coverage of at least two doses of PCV10 in children aged 2-23 months was about 80% in 2011 and 85% in 2016 [3]. A modelling study in The Gambia projected that with 100% coverage the low to middle prevalence VT (i.e. vaccine serotypes with pre-vaccination prevalence <2%) would be eliminated, as a result the prevalence of all VT in the population would decline significantly from 20.1% before vaccination to 3.0% 10 years after [26]. Such an assessment of the impact of complete vaccine coverage has not yet been done for Kenya, which uses a different formulation of PCV and the model results from The Gambia cannot be assumed to apply directly.

The absence of a booster dose in the childhood immunisation schedule can be a factor too; most developed countries, which have achieved elimination of PCV7 serotypes, have incorporated a booster dose following either a 2-dose or 3-dose primary series in infancy [27]. In a systematic review of dosing schedules, a booster dose in the second year of life following a 2-dose

primary series induces substantially higher concentrations of anti-capsular antibodies compared to a schedule with 3-dose primary series without a booster [28]. Theoretically, the higher antibody concentrations imply longer duration of protection as well as reduction in carriage the second year of life, when carriage transmission is still high. The impact of the booster dose on carriage in the second year of life might also lead to more rapid induction of herd immunity, which accelerates VT elimination. This herd immunity could compensate for the potential increased risk of acquisition, between the second and the booster doses, associated with not giving the third primary dose.

Each of the above mechanisms through which VT circulation is hypothesised to be sustained in African populations could be incorporated in the baseline model to help inform related policy questions such as: (i) is there room for increasing vaccine coverage within current regime in the effort of eliminating of VT carriage in Kenya?; (ii) will a switch to a vaccination schedule that includes a booster dose bring about elimination?; (iii) will a mass campaign in age groups with high carriage prevalence bring about elimination?; (iv) what are the considerations of the optimal extent of campaigns to eliminate VT?

Finally, there are also protein and whole cell vaccines in different stages of development and clinical trials [29]; it would be useful to project their impact on carriage and disease and whether they are cost-effective once information concerning their efficacy becomes available and mechanism of protection against carriage and disease is more clearly understood in humans.

1.4 Conclusion

PCVs, introduced into the childhood immunisation programme, are highly effective in reducing the burden of disease caused by pneumococcus.

Compared to older vaccines, PCVs are very expensive but there are ongoing efforts to lower the prices, and the development of lower cost PCV by the Serum Institute of India is one such example. Meanwhile, as other cost-reducing options are developed and assessed, sustaining the PCV10 programme beyond 2022 will depend upon Kenya's financial resources.

Kenya has not previously been in a position where it is required to pick up the full cost of a vaccine introduced in a subsidized way. The first vaccines introduced through Gavi subsidies in 2001 are the Pentavalent and Yellow fever vaccines, which continue to be almost fully funded by Gavi since Kenya currently pays 6.87% of the price per dose of US\$1.24 and US\$1.19 respectively [30]. There is some impetus from Angola, which has been fully self-financing Pentavalent Vaccine since 2016, and will support PCV in full from 2018 [31]. However, Angola's GDP per capita of US\$3110 is double that of Kenya. The Kenya National Immunization Technical Advisory Group (KENITAG) is mandated to issue recommendations to the Kenyan Ministry of Health (MoH) on national vaccine policy. KENITAG is supposed to issue these recommendations based on the best available, ideally local, supporting evidence. This work provides KENITAG with the much-needed evidence base. The PCV10 vaccine programme is cost-effective based on acceptable thresholds. However, to afford PCV vaccination Kenya will need to substantially increase the budget for routine immunization.

References

- [1] Hammitt LL, Akech DO, Morpeth SC, Karani A, Nyongesa S, Ooko M, et al. Population impact of 10-valent pneumococcal conjugate vaccine (PCV) on nasopharyngeal carriage of *Streptococcus pneumoniae* in Kilifi, Kenya. 10th Int. Symp. Pneumococci Pneumococcal Dis., Glasgow, Scotland.: 2016.
- [2] Hammitt LL, Akech DO, Morpeth SC, Karani A, Kihuha N, Nyongesa S, et al. Population effect of 10-valent pneumococcal conjugate vaccine on nasopharyngeal carriage of *Streptococcus pneumoniae* and non-typeable *Haemophilus influenzae* in Kilifi, Kenya: findings from cross-sectional carriage studies. *Lancet Glob Heal* 2014;8–10. doi:10.1016/S2214-109X(14)70224-4.
- [3] Hammitt LL, Anthony E, Morpeth SC, Mutuku A, Ojal J, Mturi N, et al. Population effect of 10-valent pneumococcal conjugate vaccine on invasive pneumococcal disease and nasopharyngeal carriage in Kilifi, Kenya. *Manuscr Prep* 2017.
- [4] Ojal J, Flasche S, Hammitt LL, Akech D, Kiti MC, Kamau T, et al. Sustained reduction in vaccine-type invasive pneumococcal disease despite waning effects of a catch-up campaign in Kilifi, Kenya: a mathematical model based on pre-vaccination data. *Vaccine* 2017;35:4561–8.
- [5] Ojal J, Goldblatt D, Tigoi C, Scott JAG. Effect of maternally-derived anti-protein and anti-capsular IgG antibodies on the rate of acquisition of nasopharyngeal carriage of pneumococcus in newborns. *Clin Infect Dis* 2017;Accepted M. doi:10.1093/cid/cix742.
- [6] Ojal J, Hammitt LL, Gaitho J, Scott JAG, Goldblatt D. Pneumococcal conjugate vaccine induced IgG and nasopharyngeal carriage of pneumococci: Hyporesponsiveness and immune correlates of protection for carriage. *Vaccine* 2017;35:4652–7.
- [7] Zhang Q, Leong SC, McNamara PS, Mubarak A, Malley R, Finn A. Characterisation of regulatory t cells in nasal associated lymphoid tissue in children: Relationships with pneumococcal colonization. *PLoS Pathog* 2011;7. doi:10.1371/journal.ppat.1002175.
- [8] Lu Y-J, Gross J, Bogaert D, Finn A, Bagrade L, Zhang Q, et al. Interleukin-17A mediates acquired immunity to pneumococcal colonization. *PLoS Pathog* 2008;4:e1000159. doi:10.1371/journal.ppat.1000159.
- [9] Ansaldi F, Canepa P, De Florentiis D, Bandettini R, Durando P, Icardi G. Increasing incidence of *Streptococcus pneumoniae* serotype 19A and emergence of two vaccine escape recombinant ST695 strains in Liguria, Italy, 7 years after implementation of the 7-valent conjugated vaccine. *Clin Vaccine Immunol* 2011;18:343–5. doi:10.1128/CVI.00383-10.
- [10] Brueggemann AB, Pai R, Crook DW, Beall B. Vaccine escape recombinants emerge after pneumococcal vaccination in the United States. *PLoS Pathog* 2007;3:1628–36. doi:10.1371/journal.ppat.0030168.
- [11] Andam CP, Hanage WP. Mechanisms of genome evolution of *Streptococcus*. *Infect Genet Evol* 2015;33:334–42.

- doi:10.1016/j.meegid.2014.11.007.
- [12] Wyres KL, Lambertsen LM, Croucher NJ, McGee L, Von Gottberg A, Liñares J, et al. Pneumococcal capsular switching: A historical perspective. *J Infect Dis* 2013;207:439–49. doi:10.1093/infdis/jis703.
- [13] Brueggemann AB, Muroki BM, Kulohoma BW, Karani A, Wanjiru E, Morpeth S, et al. Population genetic structure of *Streptococcus pneumoniae* in Kilifi, Kenya, prior to the introduction of pneumococcal conjugate vaccine. *PLoS One* 2013;8:1–12. doi:10.1371/journal.pone.0081539.
- [14] Satzke C, Turner P, Virolainen-julkunen A, Adrian P V, Antonio M, Hare KM, et al. Standard method for detecting upper respiratory carriage of *Streptococcus pneumoniae* : Updated recommendations from the World Health Organization Pneumococcal Carriage Working Group. *Vaccine* 2014;32:165–79. doi:10.1016/j.vaccine.2013.08.062.
- [15] Huang SS, Finkelstein JA, Rifas-Shiman SL, Kleinman K, Platt R. Community-Level Predictors of Pneumococcal Carriage and Resistance in Young Children. *Am J Epidemiol* 2004;159:645–54. doi:10.1093/aje/kwh088.
- [16] Ferreira DM, Neill DR, Bangert M, Gritzfeld JF, Green N, Wright AKA, et al. Controlled human infection and rechallenge with *Streptococcus pneumoniae* reveals the protective efficacy of carriage in healthy adults. *Am J Respir Crit Care Med* 2013;187:855–64. doi:10.1164/rccm.201212-2277OC.
- [17] Gordon SB, Rylance J, Luck A, Jambo K, Ferreira DM, Manda-Taylor L, et al. A framework for Controlled Human Infection Model (CHIM) studies in Malawi: Report of a Wellcome Trust workshop on CHIM in Low Income Countries held in Blantyre, Malawi. *Wellcome Open Res* 2017;2:70. doi:10.12688/wellcomeopenres.12256.1.
- [18] Wright AKA, Ferreira DM, Gritzfeld JF, Wright AD, Armitage K, Jambo KC, et al. Human nasal challenge with *streptococcus pneumoniae* is immunising in the absence of carriage. *PLoS Pathog* 2012;8:16–9. doi:10.1371/journal.ppat.1002622.
- [19] Burki TK han. Pricing of pneumococcal conjugate vaccine challenged. *Lancet Respir Med* 2015;3:427. doi:10.1016/S2213-2600(15)00194-0.
- [20] Ozawa S, Clark S, Portnoy A, Grewal S, Meghan L, Sinha A, et al. Estimated economic impact of vaccinations in 73 low- and middle-income countries , 2001 – 2020 2010:1–18. doi:10.2471/BLT.16.178475.
- [21] Roca A, Bojang A, Bottomley C, Gladstone RA, Adetifa JU, Egere U, et al. Effect on nasopharyngeal pneumococcal carriage of replacing PCV7 with PCV13 in the Expanded Programme of Immunization in The Gambia. *Vaccine* 2015;33:7144–51. doi:10.1016/j.vaccine.2015.11.012.
- [22] Davis SM, Deloria-Knoll M, Kassa HT, O'Brien KL. Impact of pneumococcal conjugate vaccines on nasopharyngeal carriage and invasive disease among unvaccinated people: Review of evidence on indirect effects. *Vaccine* 2013;32:133–45. doi:10.1016/j.vaccine.2013.05.005.
- [23] World Population Prospects - Population Division - United Nations 2017. <https://esa.un.org/unpd/wpp/DataQuery/> (accessed September 20, 2017).

- [24] Bongaarts J. Household size and composition in the developing world in the 1990s. *Popul Stud (NY)* 2001;55:263–79. doi:10.1080/00324720127697.
- [25] Mackenzie GA, Hill PC, Jeffries DJ, Hossain I, Uchendu U, Ameh D, et al. Effect of the introduction of pneumococcal conjugate vaccination on invasive pneumococcal disease in The Gambia: A population-based surveillance study. *Lancet Infect Dis* 2016;703–11. doi:10.1016/S1473-3099(16)00054-2.
- [26] Bottomley C, Roca A, Hill PC, Greenwood B, Isham V. A mathematical model of serotype replacement in pneumococcal carriage following vaccination. *J R Soc Interface* 2013;10.
- [27] Whitney CG, Goldblatt D, O'Brien KL. Dosing Schedules for Pneumococcal Conjugate Vaccine. *Pediatr Infect Dis J* 2014;33:S172–81. doi:10.1097/INF.0000000000000076.
- [28] Knoll MD, Park DE, Johnson TS, Chandir S, Loo JD, Goldblatt D, et al. Systematic Review of the Effect of Pneumococcal Conjugate Vaccine Dosing Schedules on Immunogenicity 2014;33. doi:10.1097/INF.0000000000000079.
- [29] Moffitt KL, Malley R. Next generation pneumococcal vaccines. *Curr Opin Immunol* 2011;23:407–13. doi:10.1016/j.coi.2011.04.002.
- [30] The Global Alliance for Vaccines and Immunisation. Country co-financing information sheet, Kenya. 2017.
- [31] Immunisation TGA for V and. Country co-financing information sheet, Angola. 2018.

Appendix 1: Ethical approval for statistical analysis

The secondary statistical data analysis was give local ethical approval under SSC 2273.



KENYA MEDICAL RESEARCH INSTITUTE

P.O. Box 54840-00200, NAIROBI, Kenya
Tel (254) (020) 2722541, 2713349, 0722-205901, 0733-400003; Fax: (254) (020) 2720030
E-mail: director@kemri.org info@kemri.org Website:www.kemri.org

KEMRI/RES/7/3/1

September 21, 2012

TO: MR. JOHN OJAL (PRINCIPAL INVESTIGATOR)

**THROUGH: DR. SABAH OMAR,
THE DIRECTOR, CGMR-C,
KILIFI**

Dear Sir,

RE: SSC PROTOCOL No. 2273 – 2ND REVISION (RE-SUBMISSION): STATISTICAL ANALYSIS AND MODELLING OF THE EFFECT OF CONJUGATE VACCINE AND SYSTEMIC CAPSULAR ANTIBODY ON CARRIAGE AND TRANSMISSION OF STREPTOCOCCUS PNEUMONIA IN KENYAN CHILDREN (VERSION 1.2 DATED 3RD SEPTEMBER 2012)

Reference is made to your letter dated September 3, 2012. The ERC Secretariat acknowledges receipt of the revised proposal on September 5, 2012.

This is to inform you that the Committee determines that the issues raised at the initial review (July 31, 2012) are adequately addressed. Consequently, the study is granted approval for implementation effective this **21st day of September 2012** for a period of one year.

Please note that authorization to conduct this study will automatically expire on **September 20, 2013**. If you plan to continue data collection or analysis beyond this date, please submit an application for continuation approval to the ERC Secretariat by **August 9, 2013**. The regulations require continuing review even though the research activity may not have begun until sometime after the ERC approval.

You are required to submit any proposed changes to this study to the SSC and ERC for review and the changes should not be initiated until written approval from the ERC is received. Please note that any unanticipated problems resulting from the implementation of this study should be brought to the attention of the ERC and you should advise the ERC when the study is completed or discontinued.

Work on this project may begin.

Sincerely,

**DR. CHRISTINE WASUNNA,
ACTING SECRETARY,
KEMRI ETHICS REVIEW COMMITTEE**



Appendix 2: Ethical approval for mathematical modelling work

The modelling and cost-effectiveness work is covered under the protocol SSC 1433 with matching approval from Oxford University and LSTHM under OXTREX 30-10



KENYA MEDICAL RESEARCH INSTITUTE

P.O. Box 54840-00200, NAIROBI, Kenya
Tel: (254) (020) 2722541, 2713349, 0722-205901, 0733-400003, Fax: (254) (020) 2720030
E-mail: director@kemri.org, info@kemri.org, Website: www.kemri.org

KEMRI/RES/7/3/1

March 03, 2017

TO: **PROF. ANTHONY SCOTT,
PRINCIPAL INVESTIGATOR**

THROUGH: **DR. BENJAMIN TSOFA,
THE DIRECTOR, CGMR-C,
KILIFI**

Dear Sir,

RE: **SSC PROTOCOL NO. 1433 (RESUBMISSION REQUEST FOR ANNUAL RENEWAL AND DEVIATION): AN EFFECTIVENESS STUDY IN KILIFI DISTRICT OF 10-VALENT PNEUMOCOCCAL CONJUGATE VACCINE (PCV) ADMINISTERED THROUGH ROUTINE CHILDHOOD IMMUNIZATION PROGRAMME**

Reference is made to your letter dated 20th February, 2017. The KEMRI/Scientific and Ethics Review Unit (SERU) acknowledges receipt of the revised study documents on 23rd February, 2017.

The Committee notes that the issues raised during the 260th Committee A meeting of the KEMRI/SERU held on 7th February, 2017 have been adequately addressed.

Consequently, the study is granted approval for continuation effective **March 3, 2017** through to **March 2, 2018**. Please note that authorization to conduct this study will automatically expire on **March 2, 2018**. If you plan to continue with data collection or analysis beyond this date, please submit an application for continuing approval to SERU by **January 20, 2018**.

The Committee also noted that a protocol deviation form has been submitted, as the request for annual renewal was done after the expiration date of the last approval. The measures taken to prevent this from recurring in the future are satisfactory.

You are required to submit any proposed changes to this study to the SERU for review and the changes should not be initiated until written approval from the SERU is received. Please note that any unanticipated problems resulting from the implementation of this study should be brought to the attention of the SERU and you should advise them when the study is completed or discontinued.

You may continue with the study.

Yours faithfully,

FOR: **DR. EVANS AMUKOYE,
ACTING HEAD,**



Appendix 3: Typeset published papers

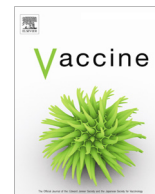

Sustained reduction in vaccine-type invasive pneumococcal disease despite waning effects of a catch-up campaign in Kilifi, Kenya: A mathematical model based on pre-vaccination data



John Ojal^{a,c,*}, Stefan Flasche^c, Laura L. Hammitt^{a,b}, Donald Akech^a, Moses C. Kiti^a, Tatu Kamau^d, Ifedayo Adetifa^{a,c}, Markku Nurhonen^e, J. Anthony G. Scott^{a,c}, Kari Auranen^{e,f}

^a KEMRI-Wellcome Trust Research Programme, Centre for Geographic Medicine-Coast, Kilifi, Kenya

^b Department of International Health, Johns Hopkins Bloomberg School of Public Health, Baltimore, MD, USA

^c Department of Infectious Disease Epidemiology, Faculty of Epidemiology and Population Health, London School of Hygiene and Tropical Medicine, London, United Kingdom

^d Kenya Ministry of Health, Nairobi, Kenya

^e Department of Public Health Solutions, National Institute for Health and Welfare (THL), Finland

^f Department of Mathematics and Statistics, University of Turku, Finland

ARTICLE INFO

Article history:

Received 24 January 2017

Received in revised form 4 July 2017

Accepted 5 July 2017

Available online 17 July 2017

Keywords:

Pneumococcal conjugate vaccine

Nasopharyngeal carriage

Kenya

Mathematical model

ABSTRACT

Background: In 2011, Kenya introduced the 10-valent pneumococcal conjugate vaccine together with a catch-up campaign for children aged <5 years in Kilifi County. In a post-vaccination surveillance study based in Kilifi, there was a substantial decline in invasive pneumococcal disease (IPD). However, given the continued circulation of the vaccine serotypes it is possible that vaccine-serotype disease may re-emerge once the effects of the catch-up campaign wear off.

Methods: We developed a compartmental, age-structured dynamic model of pneumococcal carriage and invasive disease for three serotype groups: the 10-valent vaccine serotypes and two groups of non-vaccine serotypes based on their susceptibility to mutual competition. The model was calibrated to age- and serotype-specific data on carriage and IPD in the pre-vaccination era and used to predict carriage prevalence and IPD up to ten years post-vaccination in Kilifi. The model was validated against the observed carriage prevalence after vaccine introduction.

Results: The model predicts a sustained reduction in vaccine-type pneumococcal carriage prevalence from 33% to 8% in infants and from 30% to 8% in 1–5 year olds over the 10-year period following vaccine introduction. The incidence of IPD is predicted to decline across all age groups resulting in an overall reduction of 56% in the population, corresponding to 10.4 cases per 100,000 per year. The vaccine-type IPD incidence is estimated to decline by 83% while non-vaccine-type IPD incidence is predicted to increase by 52%. The model's predictions of carriage prevalence agrees well with the observed data in the first five years post-vaccination.

Conclusion: We predict a sustained and substantial decline in IPD through PCV vaccination and that the current regimen is insufficient to fully eliminate vaccine-serotype circulation in the model. We show that the observed impact is likely to be sustained despite waning effects of the catch-up campaign.

© 2017 The Author(s). Published by Elsevier Ltd. This is an open access article under the CC BY license (<http://creativecommons.org/licenses/by/4.0/>).

1. Background

Reduction in nasopharyngeal carriage of vaccine-type pneumococci has been documented after vaccination with pneumococcal conjugate vaccines (PCVs) [1–3]. Moreover, by reducing pneumococcal acquisition, PCVs reduce pneumococcal transmission in the community offering indirect protection to the unvaccinated

[4]. However, non-vaccine-type pneumococci rapidly colonise this vacated ecological niche, which can result in serotype replacement carriage [5] and replacement disease reducing the overall impact of PCVs [6]. With support from Gavi, The Vaccine Alliance, African countries have been introducing PCVs since 2009. Kenya introduced a 10-valent PCV (PCV10) targeting serotypes 1, 4, 5, 6B, 7F, 9V, 14, 18C, 19F and 23F in 2011. In Kilifi, a coastal area with enhanced surveillance for invasive pneumococcal disease (IPD) and carriage prevalence, the introduction was supplemented by a catch-up campaign in children <5 years old. At the same time

* Corresponding author at: PO Box 230, 80108 Kilifi, Kenya.

E-mail addresses: jojal@kemri-wellcome.org, john.ojal@lshtm.ac.uk (J. Ojal).

annual carriage prevalence surveys have been conducted in the Kilifi Health and Demographic Surveillance System (KHDSS) population since 2009 [5].

Within a few months post-vaccination vaccine-type pneumococcal carriage and disease had dropped substantially in all age groups. However, vaccine serotypes (VTs) continue to circulate in the community [7,5]. This raises the concern that, after the population effects of the catch-up campaign have worn off, vaccine-type pneumococcal disease will re-emerge.

We developed a dynamic compartmental model parameterized with detailed data from the KHDSS population [8] to describe the pre-vaccination pneumococcal epidemiology and predict the long-term impact of PCV10 in Kilifi. We use post-vaccination data on carriage and disease over the past five years for validation of the model predictions.

2. Methods

2.1. Data

Kilifi County Hospital (KCH) is the main referral hospital in KHDSS. At KCH, morbidity events linked with the population register have been used to define the incidence of hospital presentation with infectious diseases, including IPD [8,9]. Datasets on pneumococcal carriage, IPD and contact patterns in KHDSS are described in detail elsewhere [5,10,11]. Here we briefly describe them as used in the current analysis.

2.1.1. Nasopharyngeal pneumococcal carriage surveys

Two cross-sectional surveys of pneumococcal carriage were done pre-vaccination. Nasopharyngeal swabs were collected and pneumococcal serotype-specific carriage ascertained [5] to obtain the pre-vaccination age-specific prevalence and serotype distribution of carriage. The two datasets were combined since there were

no significant differences between them in the carriage prevalence or serotype distribution (Appendix chapter 1).

The non-vaccine serotypes (NVTs) were classified as *weak* or *strong* based on their susceptibility to competition and carriage incidence, as estimated in a prior field study within KHDSS [12]. Strong NVTs (23B, 11A, 15A, 6A, 16F, 35B, 10A, 13, 23A 19A, 21; ordered by increasing susceptibility to competition) were less susceptible to competition. Two NVTs (34, 15B/C) were classified as strong for their higher carriage incidences compared to many of the ones chosen on the basis of susceptibility. The remaining NVTs were classified as weak (Appendix chapter 2).

2.1.2. Prospective diary survey

Selected residents from KHDSS filled in a diary on the ages of all persons they physically contacted on one randomly assigned weekday [10]. For children, the diary was completed by their guardians. This information defined a social mixing matrix of contact frequencies between age groups.

2.2. Carriage model structure

We developed a compartmental, age-structured dynamic model with 14 pneumococcal carriage states (Fig. 1). The model has a Susceptible-Infected-Susceptible (SIS) structure for three serotype groups: the PCV10 serotypes, strong NVT and weak NVT.

At any point in time, an unvaccinated individual can be susceptible (non-carrying) in state S ; carry a VT, V ; carry a weak NVT, N_w ; carry a strong NVT, N_s ; carry simultaneously a weak and strong NVT, N_{sw} ; carry simultaneously a VT and weak NVT, B_w ; or carry simultaneously a VT and a strong NVT, B_s . Once vaccinated, the individual moves to one of the corresponding states ($S^{(v)}$, $V^{(v)}$, $N_w^{(v)}$, $N_s^{(v)}$, $N_{sw}^{(v)}$, $B_w^{(v)}$, $B_s^{(v)}$). The equations of inter-state transitions are presented in Appendix chapter 3.

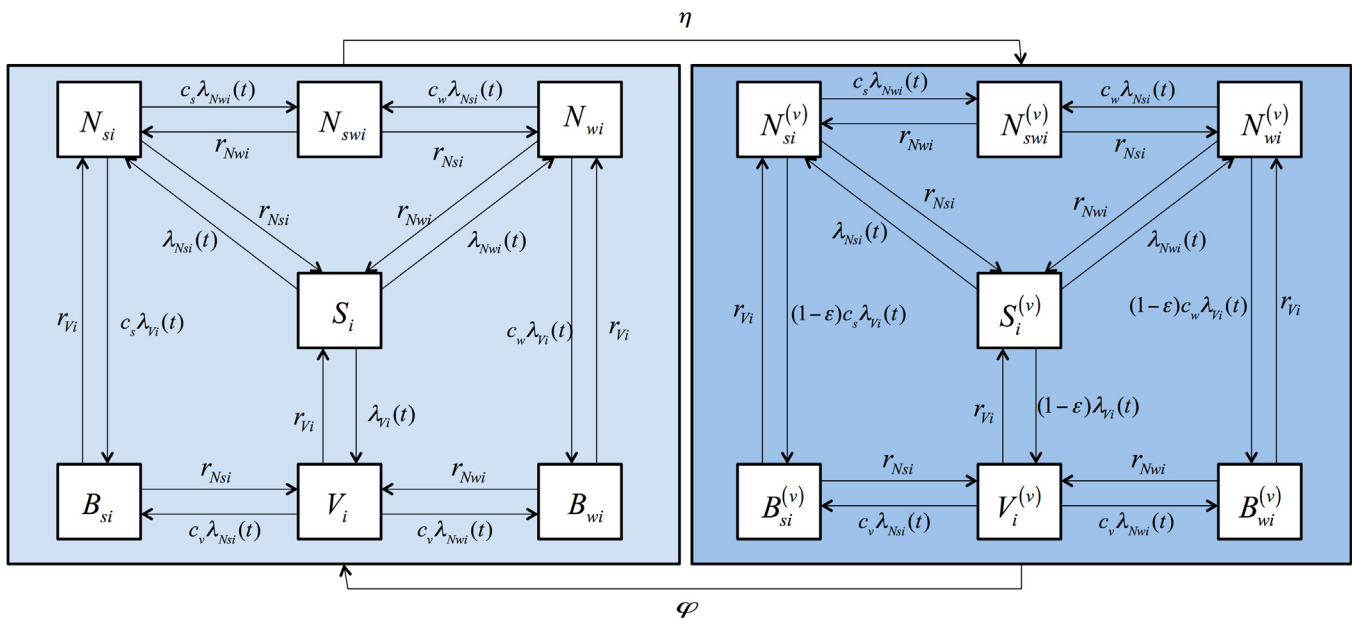

Fig. 1. Model structure flow diagram. The epidemiological states include individuals that are susceptible (non-carrying), S ; carry a vaccine serotype, V ; carry a weak non-vaccine serotype, N_w ; carry a strong non-vaccine serotype, N_s ; carry simultaneously a weak and a strong non-vaccine serotype, N_{sw} ; carry simultaneously a vaccine serotype and a weak non-vaccine serotype, B_w ; or carry simultaneously a vaccine serotype and a strong non-vaccine serotype, B_s (see text). Once vaccinated, the individual moves to one of the corresponding states, ($S^{(v)}$, $V^{(v)}$, $N_w^{(v)}$, $N_s^{(v)}$, $N_{sw}^{(v)}$, $B_w^{(v)}$ and $B_s^{(v)}$). The acquisition rates from the single to multiple serotype carriage states are reduced by competition parameters denoted by c with two subscripts; the first denoting the serotype group (v , s and w , for VT, strong NVT and weak NVT respectively) of the resident serotypes and the second denoting the age-group. The competition parameters have two sets of values, one for age group <6 and another for age group ≥ 6 years (see text). The age-group specific VT, weak NVT and strong NVT clearance rates are denoted by r_{Vi} , r_{Nwi} and r_{Nsi} , respectively. In addition to the transitions between the 14 epidemiological states as shown in the figure, individuals die from any states at age-specific death rates and new individuals are born into the completely susceptible state.

2.3. Parameterisation

2.3.1. Population structure

The model population is stratified into six age groups (<1, 1–5, 6–14, 15–20, 21–49 and ≥50 years) corresponding to those in the diary survey and reflecting the age structure in KHDSS as of 1st January 2010. Individuals in the model are born completely susceptible to carriage according to prevailing birth rates and die according to age-specific mortality rates from KHDSS (Table 1).

2.3.2. Acquisition of carriage

A susceptible unvaccinated individual in age group *i* becomes colonised with VTs, strong NVTs or weak NVTs at age-group-specific time-dependent rates (forces of infection) denoted by $\lambda_{Vi}(t)$, $\lambda_{Nsi}(t)$ and $\lambda_{Nwi}(t)$, respectively. The forces of infection were expressed as functions of the social mixing matrix and age-group specific factors (q_i) that scale the rate of social contacts into infectious contacts (Appendix chapter 3). Due to competition between serotypes in colonising the nasopharynx, the acquisition rate of a secondary serotype is lower than the acquisition rate of that serotype in a completely susceptible individual. Three competition parameters, c_{v0} , c_{w0} and c_{s0} , represent the fraction by which acquisition rates of secondary serotypes are reduced in <6 year olds infected with VTs, weak NVTs and strong NVTs, respectively. Two competition parameters, $c_{vw} = c_v = c_w$ and c_s , were used for individuals aged ≥6 years infected with VTs/weak NVTs and strong NVTs, respectively.

Table 1
Parameters of the dynamic transmission model and the sources of information. The parameters are classified as those estimated (calibrated) in the context of the model and those derived from external sources.

Parameter/input	Estimate/value (interval ^a)	Source
<i>Calibrated</i>		
Competition parameters	$c_{s0} = 0.44$ (0.13, 0.82) $c_{w0} = 0.59$ (0.19, 0.96) $c_{v0} = 0.39$ (0.15, 0.71) $c_s = 0.11$ (0.004, 0.49) $c_{vw} = c_v = c_w = 0.77$ (0.30, 0.99)	Estimated
Probability of infection per 100 contacts	$q_1 = 0.13$ (0.07, 0.25) $q_2 = 0.40$ (0.30, 0.55) $q_3 = 0.32$ (0.24, 0.43) $q_4 = 0.07$ (0.04, 0.13) $q_5 = 0.16$ (0.11, 0.23) $q_6 = 0.06$ (0.04, 0.09)	Estimated
Case-to-carrier ratios ^b	Appendix chapter 7	[11]
<i>From external sources</i>		
Clearance rates	Appendix chapter 3	[12]
Birth rate	32.0 per 1000/year	[8]
Age-specific mortality	Appendix chapter 5	[8]
Contact rates		[10]
Vaccine efficacy against carriage acquisition (ϵ)	50% (40–60)	[3,25–27]
Vaccine efficacy against IPD	85% (80–90)	[34]
Waning rate of protection against carriage (ϕ)	0.12 per year (0.09–0.20)	[35]
Routine vaccination coverage (η)	80% (70–90)	[9,11]
Catch-up coverage	65% (60–70)	[9,11]

^a The intervals indicated for the estimated parameters are 95% credible intervals. The intervals indicated for the rest of the parameters are the ranges within which they were sampled in the model to account for their uncertainty and assess the model's sensitivity.

^b IPD incidence from Kilifi district hospital in KHDSS is divided by the carriage incidence from the model to obtain case-to-carrier ratios (Appendix chapter 7).

2.3.3. Clearance of carriage

The immune clearance rates of carriage (Appendix chapter 4) depend on the serotype group and age (<1, 1–5 and >5 years) and were obtained from a prior study in Kenyan children [12].

2.3.4. Disease

For each serotype group and age group, case-to-carrier ratios were calculated as ratios of the observed IPD incidence at KCH [11] to the respective model-predicted pre-vaccination carriage incidence. The case-to-carrier ratios were assumed to remain unchanged post-vaccination and were multiplied with the predicted carriage incidence to predict post-vaccination IPD incidence.

2.3.5. Vaccination

In Kenya, children receive PCV10 at age 6, 10 and 14 weeks. In the model, $\eta=80\%$ of all newborns are considered vaccinated at age 18 weeks, one month after the third dose of the 3-dose series (Table 1). A catch-up programme is simulated by vaccinating 65% of children younger than 5 years at the onset of the vaccination programme. Upon vaccination, an individual moves to the corresponding state in the vaccine-protected compartment based on his/her prevailing carriage status.

The vaccine efficacy against carriage is modelled as a 50% reduction ($\epsilon = 0.50$) in the acquisition rate of VTs in a vaccinated individual relative to an unvaccinated individual (Table 1). The vaccine efficacy against carriage progression to disease (VE_{prog}) was calculated as a function of ϵ and the vaccine efficacy against IPD ($VE_{IPD} = 85\%$) as:

$$VE_{prog} = 1 - \frac{1 - VE_{IPD}}{1 - \epsilon} = 70\%.$$

We assumed that a proportion $\phi = 0.12$ of the vaccinated population loses their protection every year. This corresponds to an average duration of protection for an individual of just over 8 years (Table 1).

2.3.6. Implementation and model calibration

In the first stage, the stationary solution of the transmission model was fitted to the age-stratified pre-vaccination carriage prevalence and serotype distribution (Appendix chapter 1). Using a multinomial likelihood function and uninformative priors in a Bayesian framework, the five competition parameters (c_{vw} , c_{v0} , c_s , c_{s0} and c_{w0}) and six scaling/infectivity parameters ($q_1, q_2, q_3, q_4, q_5, q_6$) were estimated (Appendix chapter 5). In each iteration, bootstrapping the social contact data and reconstructing the mixing matrix incorporated uncertainty in the social contact rates. A stationary population with equal birth and mortality rates was assumed.

In the second stage, the posterior samples of model parameters obtained in the first stage were applied in a prediction model. Projections were made assuming a constant population. To measure how fast the effect of the catch-up campaign wanes, we calculated the additional cases of IPD the campaign prevents in the first 10 years and estimated the time required to achieve 90% of that effect. Simulations were performed in R [13].

2.4. Sensitivity analysis

The sensitivity of the predicted IPD incidence averted, i.e., the difference in the overall incidence of IPD before and at 10 years post-vaccination, was assessed with respect to uncertainties in the assumed levels of: (i) vaccine efficacy against carriage acquisition; (ii) vaccine efficacy against IPD; (iii) the waning rate of vaccine-induced protection against carriage; (iv) vaccine coverage.

We performed additional simulations under a growing population using birth and death rates corresponding to the local demo-

graphics [8]. The probabilities of contact per person per day were recalculated for each time step according to the current population (Appendix chapter 6).

2.5. Model validation

We visually assessed proximity of the base-case predictions of the age-group specific carriage of VTs and NVTs to the corresponding observed values over a five-year period post-vaccination (2011–2015).

3. Results

3.1. Model fit to pre-vaccination epidemiology

There was a good agreement between the observed age-group and serotype-group specific pre-vaccination carriage prevalence and their posterior estimates (Fig. 2). Within each age group, the 95% credible intervals agreed with the data. Nonetheless, the differences in the posterior mean estimates of the proportions of carriers of VTs and NVTs among pneumococcal carriers were in most instances larger than observed in individuals ≥ 6 years old, compared to the differences in individuals < 6 years old.

3.2. Competition parameters

The probability of infection per contact was higher among 1–5 and 6–14 year olds as compared to other age groups (Table 1). An individual < 6 years carrying a vaccine-serotype had a 61%

(95% credible interval, CrI, 29–85%) protection against acquiring NVTs, relative to an uninfected individual of the same age group. In older age groups, the corresponding level of protection was 23% (95% CrI 1–70%).

3.3. Model projections on pneumococcal carriage

Under the base-case model, the overall prevalence of pneumococcal carriage was estimated to remain essentially at its pre-vaccination level, with only a slight reduction from 44% to 41% within 10 years post-vaccination. The prevalence of VTs in the overall population was estimated to reduce from 16% to 4%, with a simultaneous increase in the prevalence of NVTs from 28% to 36%.

The prevalence of VTs was predicted to reduce in all age groups. In the older, mostly unvaccinated population, the reduction was estimated to be about two thirds of the pre-vaccination level (Table 2), suggesting a benefit of herd immunity. Changes in the prevalence of VTs and NVTs occur within the first 4–5 years post-vaccination and little change was predicted thereafter (Fig. 3).

3.4. Model projections on IPD

The incidence of IPD from VTs was projected to decline in all age groups. The changes in IPD and carriage were linked and over 50% reduction in IPD occurs within the first 4–5 years after PCV introduction. The overall reduction in the incidence of IPD ten years post-vaccination is predicted to be 56% (Table 3). The overall reduction in the incidence of IPD from year 5 to 10 was 7% (95% predictive interval: -0.4% to 14%). As a result of waning direct

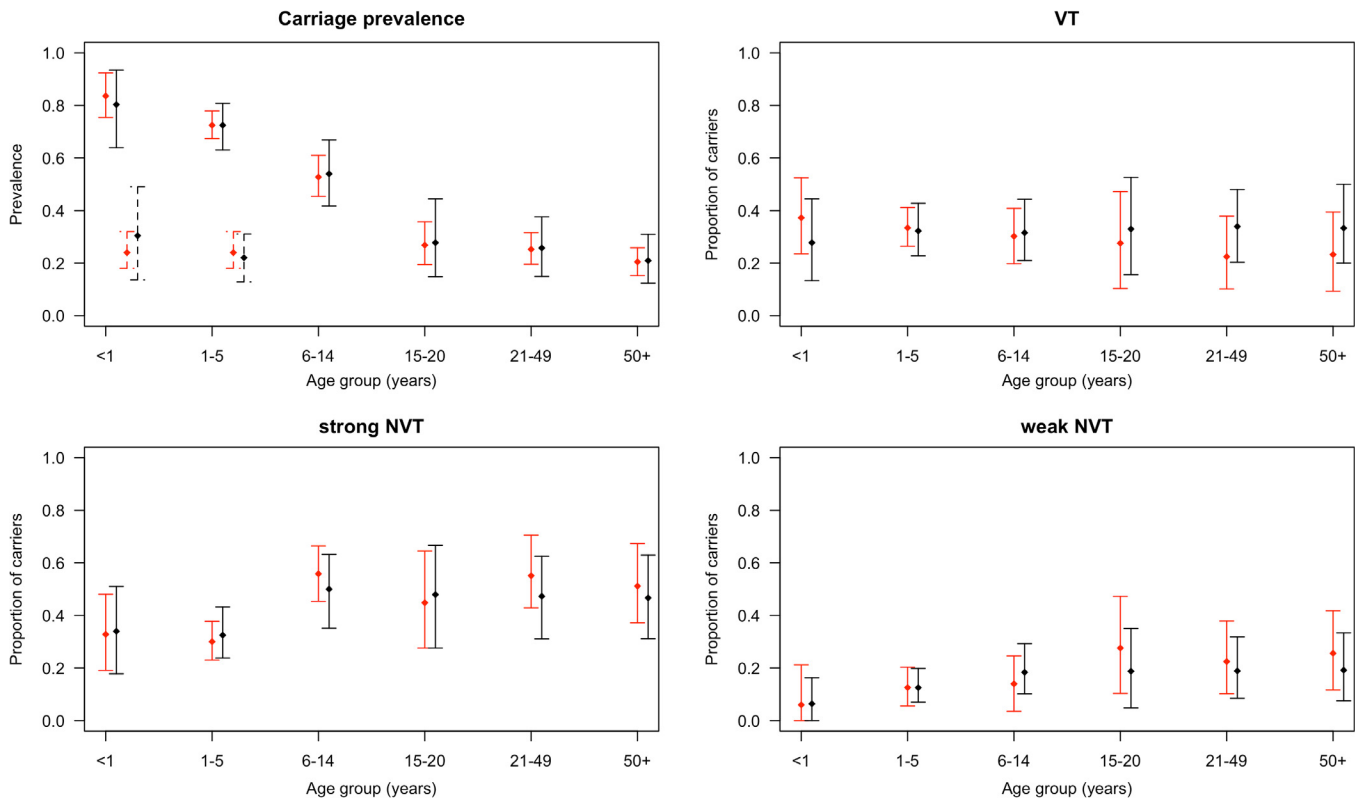

Fig. 2. Model fit. Observed prevalence (red points) of pneumococcal carriage across age groups (top-left panel) and the proportion of carriers of VT (top-right panel), strong NVT (bottom-left panel) and weak NVT (bottom-right panel) among pneumococcal carriers prior to vaccine introduction. The black points show the corresponding estimated values of the prevalence/proportion, based on data given in Appendix chapter 1. The capped bars represent the 95% credible intervals. The dotted lines in the top-left panel (and the points they pass through) are the observed (red) and the predicted (black) proportions of double carriers among < 1 and 1–5 year olds. For these two age groups, the top-right, bottom-left and bottom-right panels present the proportions of single carriers of the respective types (VT, strong NVT, weak NVT) among all carriers in the age group. (For interpretation of the references to colour in this figure legend, the reader is referred to the web version of this article.)

Table 2

The prevalence of nasopharyngeal carriage of pneumococci pre- and 10 years post-vaccination. The table presents the posterior predictive mean values with the 95% posterior predictive intervals.

Age group (years)	Pre-vaccination				10 years post-vaccination			
	Carriage prevalence	VT ^a	Strong NVT ^b	Weak NVT	Carriage prevalence	VT	Strong NVT	Weak NVT
<1	80.8 (67.8–90.1)	32.6 (25.1–40.5)	37.5 (30.6–45.8)	9.9 (7.1–13.2)	75.7 (61.4–87.2)	8.3 (1.6–18.2)	50.9 (40.9–62.6)	15.2 (10.5–22.2)
1–5	72.5 (65.2–78.5)	29.5 (23.9–35.2)	29.7 (24.6–35.2)	13.1 (9.6–17.0)	67.2 (58.9–74.6)	8.0 (1.5–16.9)	39.2 (32.2–48.5)	19.3 (14.1–25.5)
6–14	54.0 (43.1–64.8)	17.0 (13.9–21.2)	26.8 (18.9–35.0)	9.9 (7.4–13.5)	49.7 (38.6–61.0)	4.4 (0.9–9.6)	32.0 (23.6–41.2)	12.8 (9.5–17.1)
15–20	27.9 (17.0–41.7)	9.1 (5.7–13.9)	13.4 (7.6–20.7)	5.3 (3.1–8.6)	25.3 (15.6–38.0)	2.5 (0.5–6.0)	15.8 (9.5–24.3)	6.8 (4.1–10.8)
21–49	25.5 (17.0–35.5)	8.6 (5.8–12.1)	12.0 (7.6–17.5)	4.8 (3.0–7.2)	23.2 (15.2–33.0)	2.5 (0.5–5.6)	14.2 (9.2–20.9)	6.2 (3.9–9.3)
50+	21.0 (14.0–30.0)	7.1 (4.7–10.1)	9.8 (6.2–14.6)	4.0 (2.6–6.0)	19.1 (12.7–27.3)	2.0 (0.4–4.5)	11.7 (7.6–17.2)	5.2 (3.3–7.9)
Overall	44.4 (40.2–48.9)	15.9 (13.3–18.7)	20.4 (16.8–24.2)	8.0 (6.1–10.2)	40.8 (36.0–46.0)	4.3 (0.8–9.1)	25.4 (21.2–30.0)	10.9 (8.4–13.8)

^a Vaccine serotypes.

^b Non-vaccine serotypes.

effects of the catch-up campaign and increasing herd-effects of routine immunisation with time, we estimated that the incremental benefit of a catch-up over routine vaccination alone would be negligible from year 7 after introduction of PCV10.

3.5. Sensitivity analyses

Among the variables included in the sensitivity analysis, the duration of protection had the largest effect on the predicted IPD incidence averted in year 10, followed by the vaccine efficacy against carriage. The vaccine efficacy against IPD had the least influence (Fig. S1).

Assuming a growing population, the overall prevalence of carriage was projected to decline to a somewhat lower level of 35% (95% prediction interval 30–40%) ten years post-vaccination (Appendix chapter 7).

3.6. Model validation

The point predictions and corresponding 95% prediction intervals (PI) of carriage prevalence cover most of the observed values, showing good predictive ability (Fig. S2). Among <1 and 1–5 year olds the model predicted much lower carriage prevalence of NVTs in year 2015 (49% vs. 70% observed and 38% vs. 52% observed, respectively).

4. Discussion

We used a model calibrated with local data to predict the incidence of pneumococcal carriage and IPD in Kilifi, Kenya, over a 10-year period post-vaccination to assess whether additional measures have to be considered to prevent a resurgence of vaccine-type pneumococci once the impact of the catch-up campaign wanes. We validated the model against immediate post-vaccination epidemiological data, a unique exercise in pneumococcal carriage models, and found that such resurgence is unlikely if the routine immunisation programme continues.

Most PCV introductions in African countries have occurred since year 2011. Therefore, only a few years of observation are available to assess impact. A meta-analysis of four randomized trials in African children aged 9–24 months showed that carriage of VTs decreased with vaccination but the overall carriage remained the same [14]. In the United Kingdom, the overall prevalence of pneumococcal carriage was stable four years post-vaccination [15]. In our model predictions, the overall carriage prevalence remains essentially unchanged due to serotype replacement in carriage. Replacement carriage was most prominent in <6 year olds because the pre-vaccination proportion of VTs among pneumococcal

carriers was highest in young children (Appendix chapter 1). We predict that elimination of VTs in this community is unlikely. In high-income countries that have almost eliminated circulation of VTs, a reduced-dose schedule has been considered to improve the cost-effectiveness of the programme [16]. The World Health Organization (WHO) also recently convened a working group to review the policy recommendations for the optimal use of PCVs in low- and middle-income countries, which includes discussion of reduced dose schedules [17]. Theoretically, where herd protection has been established, it may be possible to sustain it using, for example, a single dose in infancy and a booster dose in the second year of life. In the Kenyan setting, however, where vaccine-type pneumococci continue to circulate several years post introduction of PCV with a catch-up campaign, it would be difficult to argue that disease prevention among infants is currently guaranteed by herd protection.

In the model presented, the incidence of IPD is predicted to decline across all age groups. The non-vaccine-type IPD incidence is expected to increase by 52%, which translates to an increase in the annual incidence of 1.9 per 100,000, suggesting little replacement disease relative to the reduction in the annual overall vaccine-type IPD incidence of 12.3 per 100,000. This is explained by the lower average case-to-carrier ratios (i.e., lower invasiveness) of the replacing non-vaccine serotypes (Appendix chapter 8).

South Africa and The Gambia introduced PCV7 in 2009 and replaced it with PCV13 in 2011 [18,19]. The reduction in vaccine-type and overall IPD reported in these countries are similar to the predictions our model produces for Kilifi, Kenya, over the first few years post-vaccination. This, however, does not validate the model because of differences across the settings. The vaccination coverage in Kenya is likely to differ from coverage in The Gambia and South Africa, and Kenya introduced PCV10. We thus validated our model predictions against observed carriage prevalence and IPD incidence in Kilifi. The model predictions were generally consistent with the observed data (Fig. S2). The model, however, underestimated prevalence of carriage of NVTs in <6 year olds in 2014–15. Relaxing the assumption of a constant population size only made minimal difference to the goodness of fit (Fig. S3).

Pneumococcal serotypes are heterogeneous in transmissibility and mutual competition [12,20]. By splitting the NVTs into two groups and allowing unequal mutual competition between these groups, our model accounts for some of this heterogeneity. We did not split VTs because we aimed to reproduce serotype replacement with as small a number of parameters as possible, by limiting the number of compartments. Splitting NVTs was preferred because the group has a larger number of serotypes and hence more heterogeneity. The model projected differing magnitudes of change in the prevalence of the strong and weak NVTs. Given the different case-to-carrier ratios of the two groups of NVTs

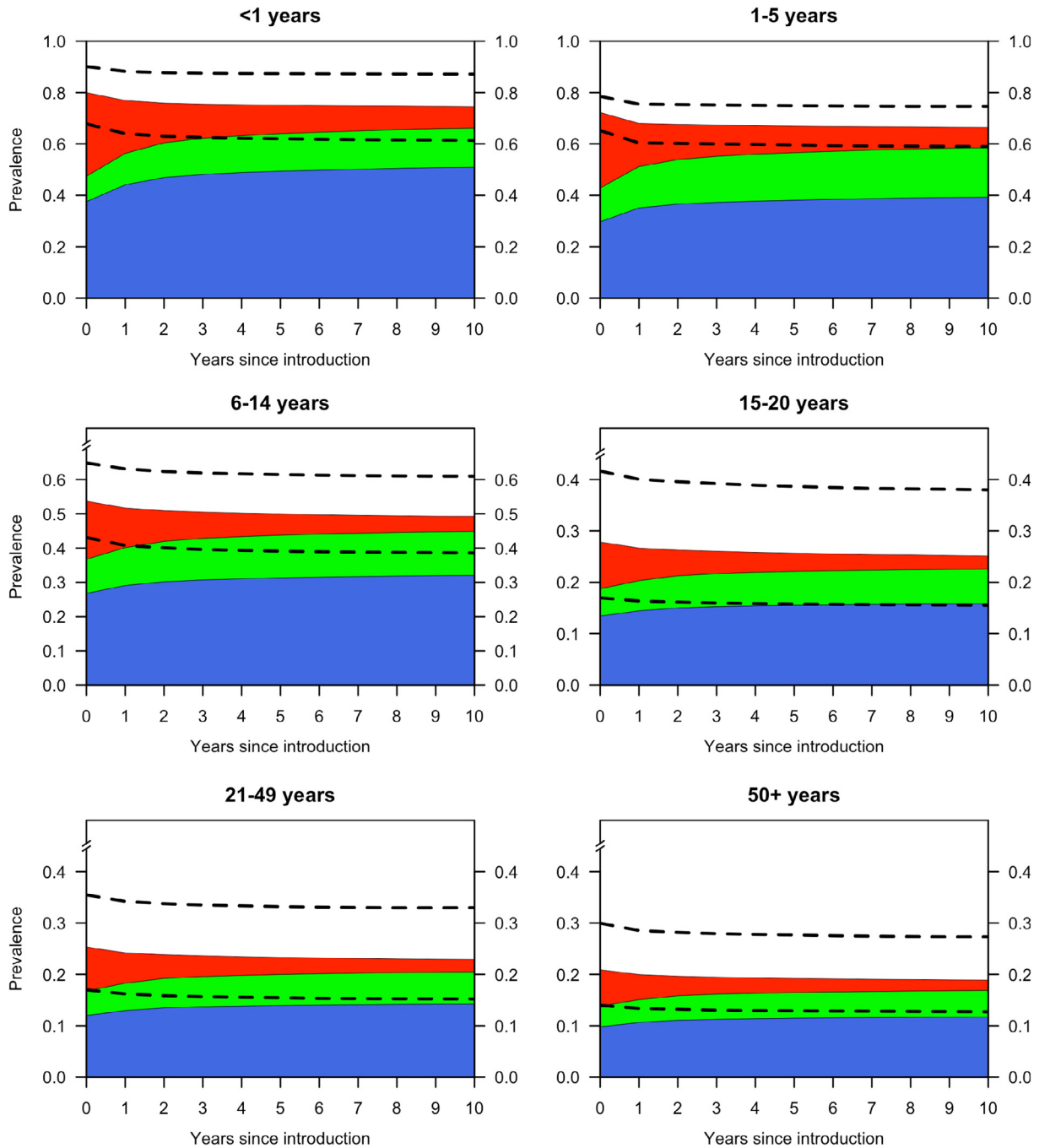

Fig. 3. Model projections on carriage prevalence over 10 years by age group. Projected cumulative prevalence of pneumococcal carriage of VT (red), strong NVT (blue) and weak NVT (lime green) by age group over time since vaccine introduction. For each age group, the dotted lines show the 95% predictive intervals for the overall prevalence of pneumococcal carriage. (For interpretation of the references to colour in this figure legend, the reader is referred to the web version of this article.)

(Appendix chapter 8), the projected non-vaccine-type IPD incidence is different from what would have been predicted using a single group of NVTs. Nonetheless, grouping serotypes can create some ‘super types’ that might have different characteristics, e.g. higher acquisition rate of the VTs group compared to the individual serotypes in the group. This might lead to conservative vaccine effectiveness estimates. Grouping of serotypes may also result in the estimated acquisition rate of NVTs being lower than that of individual serotypes in the group. This would lead to an underestimation of the indirect impact of vaccination on NVTs – lower than the observed predicted prevalence of NVTs.

To limit the number of estimated parameters, age dependency in competition was considered using two age classes (<6 and ≥ 6 years). Some discrepancies between the fitted and observed age-specific serotype distributions were present. The proportion of carriers of VTs was overestimated among carriers aged ≥ 15 years (Fig. 2); the susceptibility to competition of VTs against NVTs is likely biased downwards in adults, thus underestimating the reduction in prevalence of VTs. With our current specification, the estimates of competition parameters in age group ≥ 6 years largely depends on data from the age groups 6–14 years. A model including more groups of VTs and NVTs or individual serotypes

Table 3

The incidence of invasive pneumococcal disease (IPD) pre- and 10 years post-vaccination. The table presents the posterior predictive mean values with the 95% predictive intervals.

Age group (years)	Pre-vaccination IPD incidence (/100,000/year)			10 years post-vaccination IPD incidence (/100,000/year)			
	VT	Strong NVT	Weak NVT	VT	Strong NVT	Weak NVT	IRR ^a
<1	67.0	21.0	7.1	6.7 (1.1, 15.1)	37.0 (29.5, 50.4)	11.6 (9.4, 15.6)	0.59 (0.51, 0.72)
1–5	39.3	5.1	0.7	6.4 (1.2, 14.7)	7.8 (6.5, 10.0)	1.1 (0.9, 1.4)	0.34 (0.24, 0.50)
6–14	7.3	1.0	0.0	1.4 (0.3, 3.3)	1.2 (1.1, 1.5)	0.0 (0.0, 0.0)	0.33 (0.20, 0.54)
15–20	1.0	0.0	0.0	0.3 (0.1, 0.5)	0.0 (0.0, 0.0)	0.0 (0.0, 0.0)	0.26 (0.05, 0.54)
21–49	4.2	0.9	0.0	1.2 (0.2, 2.3)	1.1 (1.0, 1.3)	0.0 (0.0, 0.0)	0.45 (0.28, 0.66)
≥50	9.2	2.8	4.1	2.5 (0.5, 5.1)	3.4 (3.1, 3.9)	5.3 (4.7, 6.3)	0.71 (0.60, 0.82)
All ages	14.8	2.7	0.9	2.5 (0.5, 5.6)	4.2 (3.5, 5.3)	1.3 (1.1, 1.6)	0.44 (0.34, 0.56)

^a The incidence rate ratio (IRR) is between the overall IPD incidence before vaccination and the IPD incidence 10 years post vaccination.

[21–23] would allow for even more heterogeneity. However, the estimation of competition parameters from available carriage data would become increasingly difficult in a highly compartmentalized model.

We estimated case-to-carrier ratios using hospital-based data on IPD incidence in KHDSS [8]. The access to care for IPD is unknown in KHDSS, but meningitis incidence is underestimated by over 30% by hospital-based surveillance [24]. Since IPD and meningitis are severe syndromes, the underestimation of IPD incidence could be similar implying case-to-carrier ratios are likely underestimated. Nonetheless, since the ratios estimated pre-vaccination are applied post-vaccination, the predicted reduction in IPD is not affected.

We excluded partial protection from first and second doses. Our estimates of the vaccine impact may thus be conservative if the vaccines' efficacy is substantial after fewer than three doses. We treated vaccine efficacy against carriage and its waning as equal for routine and catch-up vaccination. A Kenyan trial estimated vaccine efficacy against carriage of 40% among children aged 1–4 years [3], lower than the 50% for infant vaccination [25–27]. The duration of protection of catch-up vaccination is not documented yet. One dose of PCV administered outside of infancy may have a more enduring effect than 3 routine infant doses. If so, our similar treatment of the duration of immunity means there is no inflection on the carriage prevalence of VTs as the cohort of highly immune <5 year olds who received a catch-up dose is replaced by a new birth cohort of less immune children over time.

We assumed children are born completely susceptible to acquisition of pneumococcus ignoring the influence of maternal antibodies. Newborns in a Kenyan study had a very high rate of first acquisition [20]. Early acquisition has also been reported in other African settings [28–30]. In Netherlands and Papua New Guinea a protective effect of maternal IgG antibodies against colonisation in infancy was not observed [31,32]. Based on high early acquisition rates and insufficient evidence of protection from maternal antibodies in some studies, this assumption is plausible.

A significant reduction in IPD caused by vaccine-related serotypes 6A and 19A IPD has been observed in some PCV10-using settings [33]. However, surveillance in Kilifi recorded no change in carriage of serotype 6A and increased carriage of serotype 19A after vaccine introduction [7]. We have not observed a change in IPD caused by these serotypes. We therefore did not account for 6A and 19A as vaccine serotypes.

In conclusion, we predict a substantial and sustainable decline in the carriage prevalence of VTs among vaccinated and unvaccinated individuals and consequently a reduction of about 56% in overall IPD incidence ten years post-vaccination. While we show that the current schedule is sufficient to limit vaccine-type pneumococcal carriage to current levels, it is unlikely to achieve elimination of VTs. Strategies that heavily rely on protection from the

herd, including a reduced dose schedule, will need additional efforts to stop circulation of VTs before their implementation.

Author contributions

Conceived the study: JO, KA, MN, JAGS, SF. Model coding and simulations: JO. Conducted the pneumococcal carriage surveys and/or facilitated IPD surveillance in Kilifi: LLH, DA, IA, JAGS, TK. Conducted the social contact survey: MCK. All authors: read and appraised the scientific content of the manuscript.

Ethics statement

The study was part of the Pneumococcal Conjugate Vaccine Impact Study (PCVIS) approved by the Kenya Medical Research Institute (KEMRI) Ethical review committee (SCC 1433). It has an additional approval by OXTREC (OXTREX 30-10), the Oxford Tropical Research Ethics Committee, with delegated authority from the London School of Hygiene & Tropical Medicine (LSHTM) Research Ethics Committee.

Conflict of interest

None.

Acknowledgements

This paper is published with the permission of the Director, KEMRI. The work was funded by the Wellcome Trust through fellowship support to John Ojal (092767) and Prof. Anthony Scott (098532). The social contact study was funded by Wellcome Trust fellowship to Prof. James Nokes (084633) and Moses C. Kiti (098556). We acknowledge Dr. Shahnaaz K. Sharif of the Kenya Ministry of health for his involvement in the design and conduct of the pneumococcal carriage surveys in Kilifi.

Appendix A. Supplementary material

Supplementary data associated with this article can be found, in the online version, at <http://dx.doi.org/10.1016/j.vaccine.2017.07.019>.

References

- [1] Dagan R, Givon-Lavi N, Zamir O, Sikuler-Cohen M, Guy L, Janco J, et al. Reduction of nasopharyngeal carriage of *Streptococcus pneumoniae* after administration of a 9-valent pneumococcal conjugate vaccine to toddlers attending day care centers. *J Infect Dis* 2002;185:927–36.
- [2] Dagan R, Muallem M, Melamed R, Leroy O, Yagupsky P. Reduction of pneumococcal nasopharyngeal carriage in early infancy after immunization

- with tetravalent pneumococcal vaccines conjugated to either tetanus toxoid or diphtheria toxoid. *Pediatr Infect Dis* 1997;16:1060–4.
- [3] Hammitt LL, Ojal J, Bashraheil M, Morpeth SC, Karani A, Habib A, et al. Immunogenicity, impact on carriage and reagentogenicity of 10-valent pneumococcal non-typeable *Haemophilus influenzae* protein D conjugate vaccine in Kenyan children aged 1–4 years: a randomized controlled trial. *PLoS One* 2014;9:e85459. <http://dx.doi.org/10.1371/journal.pone.0085459>.
- [4] Davis SM, Deloria-Knoll M, Kassa HT, O'Brien KL. Impact of pneumococcal conjugate vaccines on nasopharyngeal carriage and invasive disease among unvaccinated people: review of evidence on indirect effects. *Vaccine* 2013;32:133–45. <http://dx.doi.org/10.1016/j.vaccine.2013.05.005>.
- [5] Hammitt LL, Akech DO, Morpeth SC, Karani A, Kihuhu N, Nyongesa S, et al. Population effect of 10-valent pneumococcal conjugate vaccine on nasopharyngeal carriage of *Streptococcus pneumoniae* and non-typeable *Haemophilus influenzae* in Kilifi, Kenya: findings from cross-sectional carriage studies. *Lancet Glob Heal* 2014;8–10. [http://dx.doi.org/10.1016/S2214-109X\(14\)70224-4](http://dx.doi.org/10.1016/S2214-109X(14)70224-4).
- [6] Weinberger DM, Malley R, Lipsitch M. Serotype replacement in disease after pneumococcal vaccination. *Lancet* 2011;378:1962–73. [http://dx.doi.org/10.1016/S0140-6736\(10\)62225-8](http://dx.doi.org/10.1016/S0140-6736(10)62225-8).
- [7] Hammitt LL, Akech DO, Morpeth SC, Karani A, Nyongesa S, Ooko M, et al. Population impact of 10-valent pneumococcal conjugate vaccine (PCV) on nasopharyngeal carriage of *Streptococcus pneumoniae* in Kilifi, Kenya. In: 10th Int. Symp. Pneumococci Pneumococcal Dis., Glasgow, Scotland; 2016.
- [8] Scott JAG, Bauni E, Moisi JC, Ojal J, Gatakaa H, Nyundo C, et al. Profile: the Kilifi Health and Demographic Surveillance System (KHDSS). *Int J Epidemiol* 2012;41:650–7. <http://dx.doi.org/10.1093/ije/dys062>.
- [9] Adetifa IMO, Bwanaali T, Wafula J, Mutuku A, Karia B, Makumi A, et al. Cohort profile: the Kilifi vaccine monitoring study. *Int J Epidemiol* 2016;dyw202. <http://dx.doi.org/10.1093/ije/dyw202>.
- [10] Kiti MC, Kinyanjui TM, Koeh DC, Munywoki PK, Medley GF, Nokes DJ. Quantifying age-related rates of social contact using diaries in a rural coastal population of Kenya. *PLoS One* 2014;9:e104786. <http://dx.doi.org/10.1371/journal.pone.0104786>.
- [11] Scott Anthony, Hammit Laura, Karia Boniface, Mutuku Alex, Shariff Shahnaaz, Kamau Tatu, et al. Pneumococcal conjugate vaccine impact study (PCVIS) n.d. <http://kemri-wellcome.org/programme/pcvis-2/> [accessed January 13, 2017].
- [12] Lipsitch M, Abdullahi O, D'amour A, Xie W, Weinberger DM, Tchetgen ET, et al. Estimating rates of carriage acquisition and clearance and competitive ability for pneumococcal serotypes in Kenya with a Markov transition mode. *Epidemiology* 2012;23:1–10. <http://dx.doi.org/10.1097/EDE.0b013e31824f2f32>.
- [13] R Core Team. R: a language and environment for statistical computing; 2014. <https://www.r-project.org/>.
- [14] Usuf E, Bottomley C, Adegbola RA, Hall A. Pneumococcal carriage in sub-Saharan Africa—a systematic review. *PLoS One* 2014;9:e85001. <http://dx.doi.org/10.1371/journal.pone.0085001>.
- [15] Gladstone RA, Jefferies JM, Tocheva AS, Beard KR, Garley D, Wei W, et al. Five winters of pneumococcal serotype replacement in UK carriage following PCV introduction. *Vaccine* 2015;33:2015–21.
- [16] Flasche S, Van Hoek AJ, Goldblatt D, Edmunds WJ, O'Brien KL, Scott JAG, et al. The potential for reducing the number of pneumococcal conjugate vaccine doses while sustaining herd immunity in high-income countries. *PLoS Med* 2015;12:1–5. <http://dx.doi.org/10.1371/journal.pmed.1001839>.
- [17] Call for nomination for experts to serve on a Strategic Advisory Group of Experts (SAGE) on Immunization working group on Pneumococcal Conjugate Vaccine (PCV). WHO website; 2016. http://www.who.int/immunization/policy/sage/call_nominations_working_group_pcv/en/ [accessed December 21, 2016].
- [18] Mackenzie GA, Hill PC, Jeffries DJ, Hossain I, Uchendu U, Ameh D, et al. Effect of the introduction of pneumococcal conjugate vaccination on invasive pneumococcal disease in The Gambia: a population-based surveillance study. *Lancet Infect Dis* 2016;703–11. [http://dx.doi.org/10.1016/S1473-3099\(16\)00054-2](http://dx.doi.org/10.1016/S1473-3099(16)00054-2).
- [19] von Gottberg A, de Gouveia L, Tempia S, Quan V, Meiring S, von Mollendorf C, et al. Effects of vaccination on invasive pneumococcal disease in South Africa. *N Engl J Med* 2014;371. <http://dx.doi.org/10.1056/NEJMoa1401914>. 141111140010002.
- [20] Tigoi CC, Gatakaa H, Karani A, Mugo D, Kungu S, Wanjiru E, et al. Rates of acquisition of pneumococcal colonization and transmission probabilities, by serotype, among newborn infants in Kilifi district, Kenya. *Clin Infect Dis* 2012;55:180–8. <http://dx.doi.org/10.1093/cid/cis371>.
- [21] Cobey S, Lipsitch M. Niche and neutral effects of acquired immunity permit coexistence of pneumococcal serotypes. *Science* 2012;335:1376–80. <http://dx.doi.org/10.1126/science.1215947>.
- [22] Flasche S, Edmunds WJ, Miller E, Goldblatt D, Robertson C, Choi YH. The impact of specific and non-specific immunity on the ecology of *Streptococcus pneumoniae* and the implications for vaccination. *Proc Biol Sci* 2013;280:20131939. <http://dx.doi.org/10.1098/rspb.2013.1939>.
- [23] Bottomley C, Roca A, Hill PC, Greenwood B, Isham V. A mathematical model of serotype replacement in pneumococcal carriage following vaccination. *J R Soc Interf* 2013;10.
- [24] Moisi JC, Nokes DJ, Gatakaa H, Williams TN, Bauni E, Levine OS, et al. Sensitivity of hospital-based surveillance for severe disease: a geographic information system analysis of access to care in Kilifi district, Kenya. *Bull World Health Organ* 2011;89:102–11. <http://dx.doi.org/10.2471/BLT.10.080796>.
- [25] O'Brien K, Moulton L, Reid R, Weatherholtz R, Oski J, Brown L, et al. Efficacy, safety and immunogenicity of heptavalent pneumococcal conjugate vaccine in children. Northern California Kaiser Permanente Vaccine Study Center Group. *Pediatr Infect Dis J* 2000;19:187–95.
- [26] O'Brien K, Moulton L, Reid R, Weatherholtz R, Oski J, Brown L, et al. Efficacy and safety of seven-valent conjugate pneumococcal vaccine in American Indian children: group randomised trial. *Lancet* 2003;362:355–61.
- [27] Cutts FT, Zaman SMA, Enwere G, Jaffar S, Levine OS, Okoko JB, et al. Efficacy of nine-valent pneumococcal conjugate vaccine against pneumonia and invasive pneumococcal disease in The Gambia: randomised, double-blind, placebo-controlled trial. *Lancet* 2005;365:1139–46. [http://dx.doi.org/10.1016/S0140-6736\(05\)17876-6](http://dx.doi.org/10.1016/S0140-6736(05)17876-6).
- [28] Gratten M, Gratten H, Poli A, Carrad E, Raymer M, Koki G. Colonisation of *Haemophilus influenzae* and *Streptococcus pneumoniae* in the upper respiratory tract of neonates in Papua New Guinea: primary acquisition, duration of carriage, and relationship to carriage in mothers. *Biol Neonate* 1986;50:114–20.
- [29] Hill PC, Cheung YB, Akisanya A, Sankareh K, Lahai G, Greenwood BM, et al. Nasopharyngeal carriage of *Streptococcus pneumoniae* in Gambian infants: a longitudinal study. *Clin Infect Dis* 2008;46:807–14. <http://dx.doi.org/10.1086/528688>.
- [30] Montgomery J, Lehmann D, Smith T, Michael A, Joseph B, Lupiwa T, et al. Bacterial colonization of the upper respiratory tract and its association with acute lower respiratory tract infections in Highland children of Papua New Guinea. *Rev Infect Dis* 1990;Suppl. 8:S1006–16.
- [31] Lebon A, Verkaik NJ, Labout JAM, de Vogel CP, Hooijkaas H, Verbrugh HA, et al. Natural antibodies against several pneumococcal virulence proteins in children during the pre-pneumococcal-vaccine era: the generation R study. *Infect Immun* 2011;79:1680–7. <http://dx.doi.org/10.1128/IAI.01379-10>.
- [32] Francis JP, Richmond PC, Pomat WS, Michael A, Keno H, Phuanukoonnon S, et al. Maternal antibodies to pneumolysin but not to pneumococcal surface protein a delay early pneumococcal carriage in high-risk Papua New Guinea infants. *Clin Vaccine Immunol* 2009;16:1633–8. <http://dx.doi.org/10.1128/CVI.00247-09>.
- [33] Jokinen J, Rinta-Kokko H, Siira L, Palmu AA, Virtanen MJ, Nohynek H, et al. Impact of ten-valent pneumococcal conjugate vaccination on invasive pneumococcal disease in Finnish children - a population-based study. *PLoS One* 2015;10:1–11. <http://dx.doi.org/10.1371/journal.pone.0120290>.
- [34] Lucero MG, Dulalia VE, Nillos LT, Williams G, Parreño RAN, Nohynek H, et al. Pneumococcal conjugate vaccines for preventing vaccine-type invasive pneumococcal disease and X-ray defined pneumonia in children less than two years of age. *Cochrane Database Systematic Rev* 2009 2010;CD004977 [Review].
- [35] Choi YH, Jit M, Gay N, Andrews N, Waight PA, Melegaro A, et al. 7-Valent pneumococcal conjugate vaccination in England and Wales: is it still beneficial despite high levels of serotype replacement? *PLoS One* 2011;6:e26190. <http://dx.doi.org/10.1371/journal.pone.0026190>.

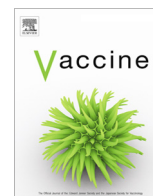

Pneumococcal conjugate vaccine induced IgG and nasopharyngeal carriage of pneumococci: Hyporesponsiveness and immune correlates of protection for carriage



John Ojal^{a,c,*}, Laura L. Hammitt^{a,b}, John Gaitho^a, J. Anthony G. Scott^{a,c}, David Goldblatt^d

^a KEMRI-Wellcome Trust Research Programme, Kilifi, Kenya

^b Department of International Health, Johns Hopkins Bloomberg School of Public Health, Baltimore, MD, USA

^c Department of Infectious Disease Epidemiology, London School of Hygiene & Tropical Medicine, London, United Kingdom

^d Great Ormond Street Institute of Child Health, University College, London, United Kingdom

ARTICLE INFO

Article history:

Received 15 March 2017

Received in revised form 28 May 2017

Accepted 30 May 2017

Available online 21 July 2017

Keywords:

Pneumococcal conjugate vaccine

Nasopharyngeal carriage

Kenya

Hyporesponsiveness

Correlates of protection

ABSTRACT

Background: Prior studies have demonstrated hyporesponsiveness to pneumococcal conjugate vaccines (PCVs) when administered in the presence of homologous carriage. This may be substantially more important in Africa where carriage prevalence is high. Deriving a correlate of protection (CoP) for carriage is important in guiding the future use of extended PCVs as population control of pneumococcal disease by vaccination is now focused principally on its indirect effect. We therefore explored the complex relationship between existing carriage and vaccine responsiveness, and between serum IgG levels and risk of acquisition.

Methods: We undertook secondary analyses of data from two previously published clinical trials of the safety and immunogenicity of PCV in Kenya. We compared responses to vaccination between serotype-specific carriers and non-carriers at vaccination. We assessed the risk of carriage acquisition in relation to PCV-induced serum IgG levels using either a step- or continuous-risk function.

Results: For newborns, the immune response among carriers was 51–82% lower than that among non-carriers, depending on serotype. Among toddlers, for serotypes 6B, 14 and 19F the post-vaccination response among carriers was lower by between 29 and 70%. The estimated CoP against acquisition ranged from 0.26 to 1.93 µg/mL across serotypes, however, these thresholds could not be distinguished statistically from a model with constant probability of carriage independent of assay value.

Conclusion: We have confirmed hyporesponsiveness in an equatorial African setting in both infants and toddlers. Population responses to vaccination are likely to improve with time as carriage prevalence of vaccine serotypes is reduced. We have not found clear correlates of protection against carriage acquisition among toddlers in this population. Assessing the potential of new vaccines through the use of CoP against carriage is still difficult as there are no clear-cut serotype specific correlates.

© 2017 The Author(s). Published by Elsevier Ltd. This is an open access article under the CC BY license (<http://creativecommons.org/licenses/by/4.0/>).

1. Introduction

The first pneumococcal conjugate vaccine (PCV), which contained seven serotypes, reduced the incidence of pneumococcal disease and the prevalence of nasopharyngeal carriage in both vaccinated and unvaccinated children as well as adults when introduced into routine infant immunisation programme in the USA in 2000 [1]. The indirect protective effect of PCV is caused by a vaccine-induced reduction in the risk of acquiring colonisation by

vaccine serotypes (VTs), which leads to a reduction in onward transmission from young children.

Recently, data have emerged that highlight the complexity of interactions between pneumococci, the human immune system and the nasopharynx. Infants carrying serotypes 6B, 19F or 23F at the time of PCV immunisation have reduced primary IgG responses to those serotypes [2,3] and this effect persists through to post-booster responses [4]. Rodenburg and colleagues showed that, at 24 months of age, children's responses to PCV against these three serotypes were reduced if they had carried them at any point in the 2 years prior to vaccination [5].

PCV responses in African children are generally thought to be higher than those seen in developed country settings [6–9]. For instance, the serotype-specific geometric mean fold-rise between

* Corresponding author at: PO Box 230- 80108, Kilifi, Kenya.
E-mail address: jojal@kemri-wellcome.org (J. Ojal).

the time of the first dose and one month after the third dose of PCV were lower in USA [7] and Finland [9] compared to South Africa [6] and The Gambia [8]. Nonetheless, in parts of Africa like The Gambia [10] and Kenya [11,12], carriage rates from very early in life are extremely high. Given high responses to PCV it is possible that hyporesponsiveness does not occur, or is immunologically irrelevant, in equatorial Africa.

The immunological mechanism that mediates vaccine-induced protection against colonisation at the mucosal level, or against disease, is not known. While circulating IgG may have a role in preventing colonisation, as demonstrated in a mouse model in which antibody blocked colonisation through agglutination [13], local B cells producing IgG and/or IgA in the nasopharynx may also be relevant and a role for T cells has also been suggested [14,15]. Nonetheless, to facilitate the licencing of new formulations of PCV, a single aggregate serological correlate of protection against invasive pneumococcal disease (IPD), has been derived based on circulating IgG [16,17]. However, a recent analysis that suggested correlates of protection (CoP) for IPD vary widely by serotype [18] has questioned the biological relevance of a single aggregate CoP common to all serotypes. It is likely that, as with IPD, the CoP against carriage also vary by serotype.

Numerous assumptions were made during the development of the common serological CoP and there is equipoise in the scientific community about the relevance of the CoP to carriage and mucosal disease [19]. For some serotypes, greater concentrations of serum IgG were likely to be required to protect at mucosal surfaces (e.g. in the nasopharynx) than in blood [20]. Subsequent analysis of vaccine-induced antibody and the prevention of carriage reinforced the notion that if circulating IgG is indeed a relevant correlate for carriage, remarkably high concentrations are required to reduce carriage acquisition [21]. Deriving CoP for carriage would guide the future use of extended PCVs, as population control of pneumococcal disease by vaccination is now focused principally on its indirect effect mediated through carriage [22].

We therefore set out to explore both the relationship between existing carriage and vaccine responsiveness and between serum IgG levels and risk of acquisition by undertaking new analyses of two existing field studies of PCV in Kenya, with the following questions: (i) Does hyporesponsiveness occur in high carriage settings like Kenya? (ii) If so, can we detect this for serotypes other than the most common (e.g. 6B, 19F and 23F)? (iii) Is it possible to derive a serological correlate of protection against carriage acquisition using vaccine-induced IgG responses detected within randomized controlled trials of PCV in Kenya?

2. Methods

2.1. Data

Data from two previously published clinical trials of the safety and immunogenicity of PCV conducted in Kenya [14,15] were further analysed in the current study. The first study (“Newborn study”) recruited 300 newborns that were randomized to receive 7-valent PCV (PCV7) in one of two vaccine schedules; at 0–10–14 weeks or at 6–10–14 weeks. The subjects received a PCV7 or 23-valent Pneumococcal Polysaccharide Vaccine (PPV23) booster dose of at 36 weeks. Serological measurements were made at 0, 6, 10, 14, 18, 36 and 37 weeks and nasopharyngeal carriage ascertained at 18 and 36 weeks. The objectives of this study were to examine the effect of a newborn vaccination schedule with PCV7 on the development of antibody and carriage prevalence. In the current analysis we used the carriage data at the time of the booster (week 36) and the serological measurements at week 36 and week 37.

The second study (“Toddler study”) recruited 600 children aged 1–4 years to examine the effect of 0, 1 or 2 doses of a 10-valent PCV (PCV10), on capsular antibody concentrations and nasopharyngeal carriage. Children were given PCV10 in three different schedules: Group A received PCV10 at day 0 and day 60; Group B received PCV10 at day 0 and day 180. Diphtheria-tetanus-pertussis (DTaP) was given as a control vaccine to group A at day 180 and to Group B at day 60. A third group, which is not considered in this analysis, received Hepatitis A virus (HAV) at day 0 and day 180 and DTaP at day 60. Antibody measurements were made at days 0, 30, 90 and 210 and nasopharyngeal carriage assessed at days 0, 30, 60, 90 and 180. Details of the study have been published elsewhere [23]. In the current analysis we used carriage data from vaccinees in Groups A and B at day 0, 60 and 180 (vaccination time points), and serological measurements 30 days post vaccination i.e. at 30, 90 and 210 days, respectively.

2.2. Analysis

For the newborn study, we calculated the fold-rise in serotype-specific geometric mean concentrations (GMC) between weeks 36 and 37, separately, for carriers and non-carriers for each of the seven serotypes in PCV7. The differences between the two groups (homologous carriers vs. non-carriers) were quantified as ratios of the GMC fold-rises. These ratios were derived from log-linear regression models of the booster response taking account the vaccine schedule group (6–10–14 vs 0–10–14), type of booster given (PCV7 vs PPV23) and the baseline log-concentration of IgG, at 36 weeks. Baseline IgG concentrations is adjusted for since individuals with lower concentrations have more room for greater fold-rise than individuals who already have high concentration at baseline.

For the toddler study, we pooled paired carriage data and 30-day serological responses for each of the time points of PCV10 vaccination (0, 60 and 180 days). We calculated serotype-specific fold-rises in IgG concentration 30 days later (at 30, 90 and 210 days). There were no blood samples at time 60 and 180 by design therefore we used the IgG at time 30 to adjust for responses to vaccines given at 60 and 180 days. We would expect antibody concentrations to decay from day 30 to day 60 (and from day 30 to day 180) at the same rate for subjects in both Group A and Group B; therefore, the ranks in IgG baseline between time 30 days and the time of vaccination are likely to be highly correlated, provided that natural boosting is also distributed equally in both groups. To assess the impact of carriage at the time of vaccination, GMC fold-rise ratios between homologous carriers vs. non-carriers were estimated from log-linear serotype-specific regression models of the individual level fold-rise on the carriage status, taking account of the vaccine group (Group A and B), age group (12–23, 24–35, 36–47 and 48–59 months), season (month of sample collection) and pre-vaccine (day 0 or 30) log IgG. We used Generalized Estimating Equations (GEE) to account for the correlations between the repeated measures within an individual. Data for serotypes 6B, 9V, 14, 19F and 23F were selected for the analysis since they were the most frequently carried of the 10 vaccine-type serotypes. As a supplementary analysis, we also calculated the post-vaccination GMC by pre-vaccination carriage status for both the newborn and toddler studies.

In order to derive the serotype-specific antibody threshold for vaccine efficacy against acquisition, we restricted our analysis to data from the toddler study and, in particular, to toddlers who were non-carriers at day zero. We compared carriage status at day-30 against vaccine-induced IgG concentration measured at day 30. We fitted to these two variables a model that incorporates a threshold parameter that is estimated through a profile likelihood [24], the a:b model. The model is a step-shaped function

where the step corresponds to the antibody threshold. Thus, in addition to the threshold parameter, the model also contains two parameters for constant but different acquisition probabilities below and above the threshold. A test for the presence of a threshold was achieved by comparing the a:b model to a model with constant probability of acquisition independent of assay value, using a likelihood ratio test. Confidence intervals around the threshold estimates were constructed through bootstrapping.

The a:b model does not allow for adjustment of covariates, therefore, we also modelled the risk of serotype-specific acquisition as a continuous function of log-IgG concentration in a Cox proportional hazards model that accounted for age group, carriage of a heterologous serotype at the point of vaccination, log IgG on the day of vaccination and season. Non-linear relationship between the acquisition incidence and log-IgG concentration was allowed through restricted cubic splines. Having no colonisation by any serotype at day 0 predisposes one to considerably higher risk of colonisation by an index serotype relative to someone colonised by a different serotype to the index at day 0, due to serotype competition [25,26]. This was the rationale for including carriage of a heterologous serotype at the point of vaccination in the model.

3. Results

In the newborn study, 235 pairs of 36- and 37-week samples were analysed. In these subjects the prevalence of carriage of PCV7 serotypes at 36 weeks ranged from 0.9% for serotype 23F to 12.8% for serotype 19F. Compared to non-carriers, the GMC fold-rise between week 36 and week 37 among carriers was substantially lower by a factor of 51–82% (Table 1). The point estimates of the GMC at post-booster (37 weeks) were higher among non-carriers at the point of vaccination, except of serotype 18C (Supplementary Table S1).

Table 1
Newborn study. Geometric mean fold rise between 36 and 37 weeks (with 95% confidence limits) stratified by carrier status, as well as the difference in the response between carriers and non-carriers expressed as a ratio. These ratios, and associated p values were derived from log-linear regression models of the booster response taking account of the vaccine group (EPI vs newborn), the type of booster given (Pneumococcal polysaccharide vaccine vs Pneumococcal conjugate vaccine) and log IgG in week 36.

Serotype	Carriers at 36 weeks		Non-carriers at 36 weeks		Ratio (95% CIs) for carrier/non-carrier	P-value
	n	GM fold-rise 37/36 Weeks (95% CI)	n	GM fold-rise 37/36 Weeks (95% CI)		
4	0	–	235	4.92 (4.36–5.55)	–	–
6B	6	2.85 (0.69–11.68)	229	13.52 (11.52–15.88)	0.18 (0.07–0.46)	<0.001
9V	4	1.62 (0.64–4.11)	231	5.32 (4.72–6.00)	0.31 (0.14–0.69)	0.005
14	10	1.29 (0.86–1.92)	225	2.79 (2.47–3.15)	0.49 (0.30–0.80)	0.004
18C	3	1.25 (0.87–1.79)	232	7.74 (6.87–8.73)	0.15 (0.05–0.40)	<0.001
19F	30	1.91 (1.34–2.73)	204	7.19 (6.11–8.45)	0.32 (0.21–0.48)	<0.001
23F	2	3.59 (0.02–663.49)	231	10.33 (8.80–12.14)	0.25 (0.06–1.09)	0.064

n: number of individuals.

Table 2
Toddler study. Geometric mean fold-rise between day 0 to 30 or day 30 to 90/210 stratified by carrier status at the time of vaccination (day 0, 60 or 180), as well as the difference in the response between carriers and non-carriers expressed as a ratio. The ratios and associated p-values were derived from log-linear serotype specific regression models, using GEE, of the individual level fold-rise on the carriage status, taking account of the vaccine group (Group A and B), age group (12–23, 24–35, 36–47 and 48–59 months), season (month of swab) and pre-vaccine (day 0 or 30) log IgG.

Serotype	Carriers at point of vaccination		Non-carriers at point of vaccination		Ratio (95% CIs) for carrier/non-carrier	P-value
	n ^a	GM fold-rise (95% CI)	n ^a	GM fold-rise (95% CI)		
6B	23	1.65 (1.22–2.24)	457	2.35 (2.14–2.59)	0.70 (0.51–0.97)	0.034
9V	10	1.88 (0.98–3.61)	466	3.06 (2.65–3.53)	1.53 ^b (0.89–2.65)	0.119
14	15	3.02 (1.99–4.58)	445	5.32 (4.65–6.10)	0.71 (0.50–1.02)	0.067
19F	38	2.12 (1.57–2.87)	439	7.61 (6.50–8.90)	0.30 (0.19–0.46)	<0.001
23F	22	3.39 (1.35–8.47)	455	4.28 (3.66–5.00)	1.01 (0.63–1.63)	0.955

^a There are two repeated measures for almost all participants. These numbers reflect the number of samples rather than individuals.

^b The reason why the adjusted ratio is above 1 (instead of approx. $1.88/3.06 = 0.61$, which is the unadjusted ratio) is because one of the factors adjusted for (pre-vaccine log IgG) was unevenly distributed among carriers vs. non-carriers; the GMC of pre-vaccine log IgG among carriers was significantly higher at 1.61 compared to 0.49 in non-carriers. Similar case for 23F.

In the toddler study, between 460 and 480 samples were analysed depending on serotype. The carriage prevalence at the time of vaccination ranged from 2.1% for serotype 9V to 8.0% for serotype 19F (Table 2). For serotypes 6B, 14 and 19F the GMC fold-rise post vaccination among carriers was lower by between 29 and 70%. For serotype 9V and 23F the GMC fold-rise were 53% and 1% higher among carriers (Table 2). Except for serotype 9V the point estimates of the GMC post-vaccination were higher among non-carriers at the time of vaccination (Supplementary Table S2).

We computed the serological threshold for vaccine efficacy against acquisition among serotype-specific non-carriers at the first vaccination time-point (day 0) by using their titers and carriage status 30 days later in the toddler study. The estimated thresholds ranged from 0.26 to 1.93 $\mu\text{g}/\text{mL}$ across serotypes, however, a test for the presence of a threshold at these points suggested no significant difference from a model with constant probability of acquisition independent of assay value (Table 3).

We analysed carriage acquisition as a continuous function of log IgG. There was no convincing monotonically decreasing rate of carriage with increasing log IgG for each of the five serotypes (Fig. 1). In a situation where a higher level IgG had strong negative impact on carriage, the prevalence ratios below the average (mean/median) log IgG would be above 1 and the prevalence ratios above the average log IgG would be below 1, in the plots.

4. Discussion

While inferior quantitative antibody responses to the colonising serotypes have been reported amongst children vaccinated with PCV in Philippines [2], Israel [3] and South Africa [27], none have studied this phenomenon in high carriage settings such as Equatorial Africa. Using data from two clinical trials in Kenya, we have

Table 3

Toddler study. The serotype-specific serological thresholds for vaccine efficacy against acquisition for five most commonly carried serotypes at day 0. The thresholds are computed using a step-shaped function where the step corresponds to the threshold with different infection probabilities below and above the threshold. The threshold with the highest profile likelihood is chosen as the parameters estimate. Confidence intervals are constructed by bootstrapping.

Serotype	Threshold (95% CI)	Carriage prevalence Ratio ^a (95% CI)	Test for presence of a threshold ^b	Goodness of fit p-value ^c
6B	0.48 (0.07–2.68)	0.21 (0.04–0.72)	0.079	0.048
9V ^d	1.86 (1.86–22.67)	–	>0.999	0.219
14	0.26 (0.16–14.34)	0.26 (0.04–0.87)	0.542	0.851
19F	1.66 (0.85–6.60)	0.10 (0.00–0.60)	0.171	0.314
23F ^e	1.93 (0.09–1.94)	0.00 (0.00–0.00)	0.430	0.625

^a Carriage prevalence ratio is the carriage risk above the threshold divided by carriage risk below threshold, the confidence interval is obtained by bootstrapping

^b A likelihood ratio test for the presence of a threshold. Achieved by comparing the a:b model to a model with constant probability of infection independent of assay value. Values above 0.05 indicate no sufficient evidence of a difference in the two models at % level of significance.

^c This is the Hosmer and Lemeshow goodness of fit p-value testing the null hypothesis that there is no difference between observed and model predicted values. The test assesses whether the step function represented by the a:b model is an appropriate representation of infection or whether another relationship such as a gradual one between titer and infection might be more likely than a stepped relationship. All the p-values, except that for serotype 6B, which is borderline, are above 0.05 indicating insufficient evidence against the null hypothesis at the 5% level of significance.

^d There were no carriers of serotype 9V below the threshold of 1.86 mcg/ml hence the risk ratio was undefined.

^e There were no carriers of serotype 23F above the threshold of 1.93 mcg/ml hence the risk ratio was zero.

confirmed hyporesponsiveness in equatorial Africa in both infants and toddlers, and for the first time described it in serotype 14.

The reduced immune responses to PCV administered to an individual with prevailing carriage may reduce the vaccine's efficacy. The clinical implication of this is an increased susceptibility to acquisition of homologous pneumococcal serotypes, particularly when the reduction in immune response results in lower than sufficient protection against carriage. Several strategies can be useful in high carriage settings to counter the effect of hyporesponsiveness. The use of a catch-up campaign at the time of PCV introduction can speed-up the reduction in vaccine-type carriage thus improving the immune responses in cohorts vaccinated in the subsequent period of reduced carriage. Using a booster dose in the second year of life can also be used to overcome hyporesponsiveness [3]. However, the cost-effectiveness of such strategies needs to be evaluated to provide further evidence for or against their use.

We assessed the association between IgG concentration and the incidence of carriage in two ways; using a step function, the a:b model, which explicitly models a threshold and using a model with carriage incidence as a continuous function of IgG concentration, which does not explicitly model a threshold. The second approach allowed us to study the relation while accounting for potential confounding factors. The result from each of the approaches is mutually important and complementary in interpreting results from the alternative approach.

The CoP for carriage were generally higher than the recently derived serotype-specific CoP for IPD with the exception of serotype 14 (0.26 µg/ml for carriage acquisition vs. 0.46 µg/ml for IPD) [18]. It is expected that the CoP for carriage should be substantially higher than that for IPD; therefore, the result for serotype 14 is surprising. The evidence for the CoP for carriage being lower is, however, limited given the wide 95% confidence intervals of the CoP estimate of this serotype (Table 3) and the function of IgG that does not show drastic change around the estimated CoP (Fig. 1).

For serotype 9V, all the carriers were above the estimated CoP against acquisition. This scenario reflects one of the potential problems with the a:b model, that in the estimation process the incidence below a candidate threshold is not restricted to be higher than that above it. This requirement is, however, imposed post-estimation in the test for the existence of a threshold at the estimated value [24], such that the test statistic always yields a non-significant result in such cases. Whether circulating IgG is the correct correlate of protection also needs to be considered. The exact mechanism by which pneumococci are prevented from colonising the nasopharynx is still unclear.

The licensing of future PCVs will likely take into account the potential impact on carriage [28]. Therefore, defining the CoP for

carriage would provide a way of assessing the non-inferiority of new vaccines as has been the case for CoP for IPD [16,17]. However, until a better understanding of existing CoP for IPD exists this may be complex. For example, there is limited information to sufficiently explain why IPD correlates for some serotypes are high and others low. Consequently, predicting whether the CoP for a novel serotype will be higher or lower, and by what factor, than available CoP for other serotypes is difficult. New PCVs might incorporate serotypes that are carried relatively infrequently further complicating the use of CoP for carriage. Only one previous study that was conducted in the United Kingdom has reported on PCV CoP for carriage where a clear threshold against carriage for a single serotype, serotype 14, was identified [20]. A second study in the Navajo Nation and White Mountain Apache tribal lands, in USA, did not find identifiable IgG threshold level that was associated with prevention of carriage acquisition for all the eight serotypes studied [29].

A limitation of the newborn study is that the period between booster dose and the assessment of its effect was one week. It generally takes about 4 weeks for a full immune response following vaccination. Therefore, what we show is that the impact of pre-existing carriage on immune response is notable as early as one week. It is possible that after 4 weeks the final concentrations between carriers and non-carriers are similar. If that is the case then the effect of pre-existing carriage is in delaying immune response. From the toddler study, in which there was sufficient time-lapse between vaccination and assessment of response, the final concentrations were still different between carriers and non-carriers. It is unlikely that the case is different for newborns, because the mechanism causing hypo-responsiveness should be similar between the two age groups.

In conclusion, we have confirmed hyporesponsiveness in an equatorial African setting in both infants and toddlers. Pneumococcal conjugate vaccines have been introduced in many African countries where carriage is generally high. Hyporesponsiveness might reduce the vaccine's effectiveness in the early years of introduction when the prevalence of vaccine serotypes is still high. If so, the speed with which vaccine-type carriage prevalence is reduced will determine how fast improved responses are realised in later years after vaccine introduction, when cohorts of children with reduced vaccine-type carriage rates replace the cohorts in high prevalence period. We did not identify clear correlates of protection against carriage acquisition among toddlers in this population. Given the limited information from the few studies that have reported on correlate of protection against carriage, assessing the potential of new vaccines through the use of correlate of protection against carriage remains difficult, as there are no clear-cut serotype-specific correlates.

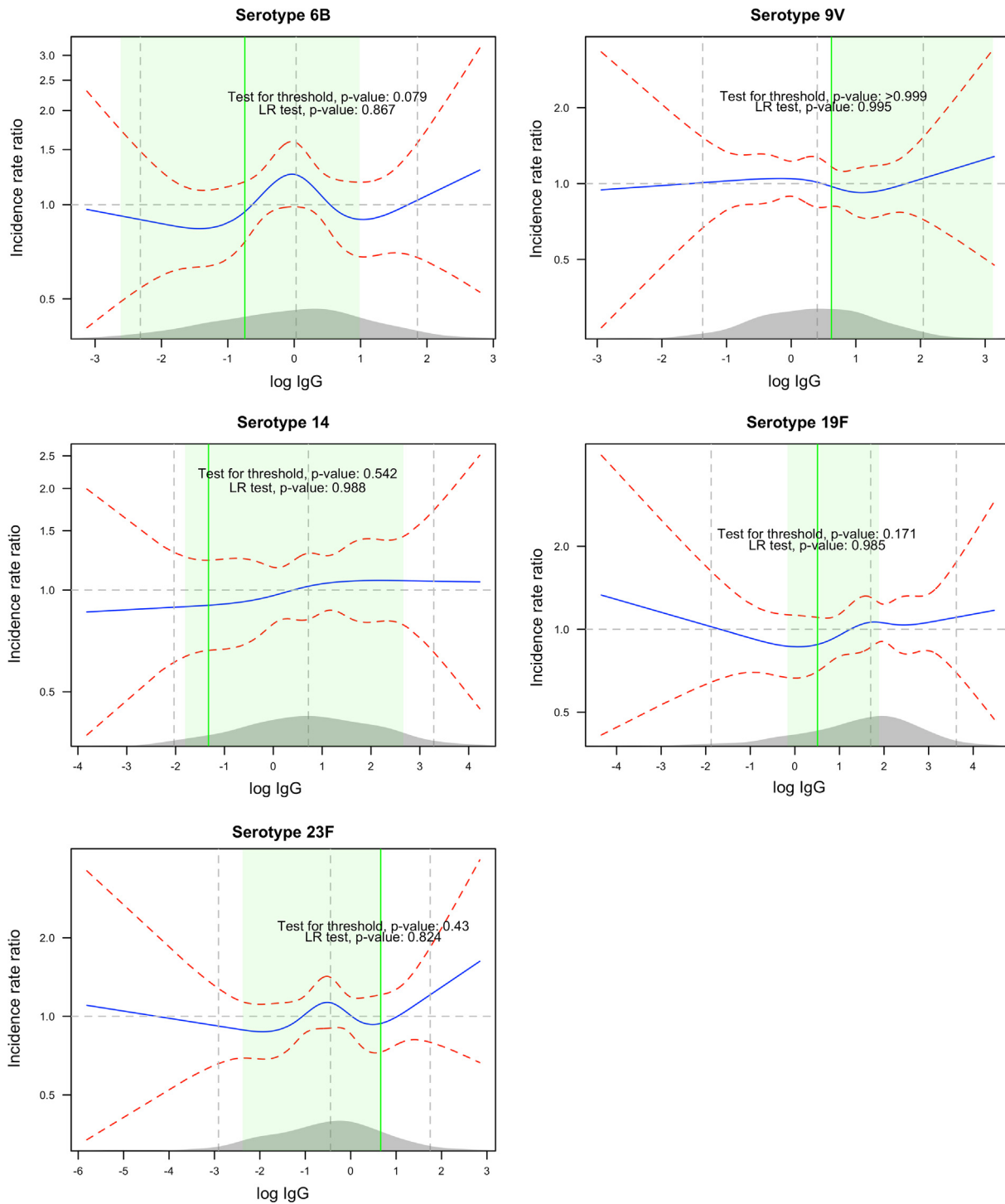

Fig. 1. The incidence rate ratio (blue solid line) as a function of log IgG titre (x-axis) for each serotype labeled above the graph. The ratios are between the values of log IgG on the x-axis relative to someone with the average log IgG. For instance, for serotype 6B, the rate ratio between individuals with log IgG of -3 relative to individuals with the mean log IgG is slightly below 1 (95% CI: ~ 0.5 to 2). The red dashed lines are the 95% CI bounds of the rate ratio. The three vertical (grey) lines mark the 2.5th, 50th and 97.5th percentiles of the distribution of log IgG whose density is shown in grey on the x-axis. The green line shows the CoP obtained by the a:b model while the light green shade around it shows the region covered by the bootstrapped 95% CI of that CoP. The likelihood ratio (LR) test p-value for the significance of log IgG in predicting carriage acquisition and the test for the presence of a threshold estimated by the a:b model is indicated in the plot. (For interpretation of the references to color in this figure legend, the reader is referred to the web version of this article.)

Funding

The work was supported by the Wellcome Trust fellowships [092767 to JO, 098532 to JAGS].

Conflict of interest

LLH has received institutional research grants from Pfizer and GlaxoSmithKline. The rest of the authors do not have a commercial or other association that might pose a conflict of interest.

Ethical approval

This paper is published with the permission of the Director, Kenya Medical Research Institute. The study was approved by the Kenya Medical Research Institute National Ethical Review Committee (SSC 2273).

Appendix A. Supplementary material

Supplementary data associated with this article can be found, in the online version, at <http://dx.doi.org/10.1016/j.vaccine.2017.05.088>.

References

- [1] Myint TTH, Madhava H, Balmer P, Christopoulou D, Attal S, Menegas D, et al. The impact of 7-valent pneumococcal conjugate vaccine on invasive pneumococcal disease: a literature review. *Adv Ther* 2013;30:127–51. <http://dx.doi.org/10.1007/s12325-013-0007-6>.
- [2] Väkeväinen M, Soininen A, Lucero M, Nohynek H, Auranen K, Mäkelä PH, et al. Serotype-specific hyporesponsiveness to pneumococcal conjugate vaccine in infants carrying pneumococcus at the time of vaccination. *J Pediatr* 2010;157(778–783):e1. <http://dx.doi.org/10.1016/j.jpeds.2010.04.071>.
- [3] Dagan R, Givon-Lavi N, Greenberg D, Fritzell B, Siegrist C-A. Nasopharyngeal carriage of *Streptococcus pneumoniae* shortly before vaccination with a pneumococcal conjugate vaccine causes serotype-specific hyporesponsiveness in early infancy. *J Infect Dis* 2010;201:1570–9. <http://dx.doi.org/10.1086/652006>.
- [4] Licciardi PV, Russell FM, Balloch A, Burton RL, Nahm MH, Gilbert G, et al. Impaired serotype-specific immune function following pneumococcal vaccination in infants with prior carriage. *Vaccine* 2014;32:2321–7. <http://dx.doi.org/10.1016/j.vaccine.2014.02.064>.
- [5] Rodenburg GD, van Gils EJM, Veenhoven RH, Bogaert D, van den Dobbelsteen GPJM, Berbers GAM, et al. Lower immunoglobulin G antibody responses to pneumococcal conjugate vaccination at the age of 2 years after previous nasopharyngeal carriage of *Streptococcus pneumoniae*. *J Pediatr* 2011;159(965–70):e1. <http://dx.doi.org/10.1016/j.jpeds.2011.06.011>.
- [6] Mbelle N, Huebner RE, Wasas AD, Kimura A, Chang I, Klugman KP. Immunogenicity and impact on nasopharyngeal carriage of a nonavalent pneumococcal conjugate vaccine. *J Infect Dis* 1999;180:1171–6. <http://dx.doi.org/10.1086/315009>.
- [7] O'Brien K, Moulton L, Reid R, Weatherholtz R, Oski J, Brown L, et al. Efficacy, safety and immunogenicity of heptavalent pneumococcal conjugate vaccine in children. Northern California Kaiser Permanente Vaccine Study Center Group. *Pediatr Infect Dis J* 2000;19:187–95.
- [8] Obaro SK, Adegbola RA, Chang I, Banya WA, Jaffar S, Mcadam KW, et al. Safety and immunogenicity of a nonavalent pneumococcal vaccine conjugated to CRM197 administered simultaneously but in a separate syringe with diphtheria, tetanus and pertussis vaccines in Gambian infants. *Pediatr Infect Dis J* 2000;19:463–9.
- [9] Nurkka A, Ahman H, Korkeila M, Jääntti V, Käyhty H, Eskola J. Serum and salivary anti-capsular antibodies in infants and children immunized with the heptavalent pneumococcal conjugate vaccine. *Pediatr Infect Dis J* 2001;20:25–33. 10.1097/00006454-200101000-00006.
- [10] Hill PC, Cheung YB, Akisanya A, Sankareh K, Lahai G, Greenwood BM, et al. Nasopharyngeal carriage of *Streptococcus pneumoniae* in Gambian infants: a longitudinal study. *Clin Infect Dis* 2008;46:807–14. <http://dx.doi.org/10.1086/528688>.
- [11] Tigoi CC, Gatakaa H, Karani A, Mugo D, Kungu S, Wanjiru E, et al. Rates of acquisition of pneumococcal colonization and transmission probabilities, by serotype, among newborn infants in Kilifi District, Kenya. *Clin Infect Dis* 2012;55:180–8. <http://dx.doi.org/10.1093/cid/cis371>.
- [12] Hammitt LL, Akech DO, Morpeth SC, Karani A, Kihuha N, Nyongesa S, et al. Population effect of 10-valent pneumococcal conjugate vaccine on nasopharyngeal carriage of *Streptococcus pneumoniae* and non-typeable *Haemophilus influenzae* in Kilifi, Kenya: findings from cross-sectional carriage studies. *Lancet Glob Heal* 2014;8–10. [http://dx.doi.org/10.1016/S2214-109X\(14\)70224-4](http://dx.doi.org/10.1016/S2214-109X(14)70224-4).
- [13] Zangari T, Wang Y, Weiser JN. *Streptococcus pneumoniae* transmission is blocked by type-specific immunity in an infant mouse model. *MBio* 2017;8:e00188–e217. <http://dx.doi.org/10.1128/mBio.00188-17>.
- [14] Pido-Lopez J, Kwok WW, Mitchell TJ, Heyderman RS, Williams NA. Acquisition of pneumococci specific effector and regulatory Cd4 + T cells localising within human upper respiratory-tract mucosal lymphoid tissue. *PLoS Pathog* 2011;7:10.1371/journal.ppat.1002396.
- [15] Lu Y-J, Gross J, Bogaert D, Finn A, Bagrade L, Zhang Q, et al. Interleukin-17A mediates acquired immunity to pneumococcal colonization. *PLoS Pathog* 2008;4:e1000159. <http://dx.doi.org/10.1371/journal.ppat.1000159>.
- [16] Jódar L, Butler J, Carlone G, Dagan R, Goldblatt D, Käyhty H, et al. Serological criteria for evaluation and licensure of new pneumococcal conjugate vaccine formulations for use in infants. *Vaccine* 2003;21:3265–72. [http://dx.doi.org/10.1016/S0264-410X\(03\)00230-5](http://dx.doi.org/10.1016/S0264-410X(03)00230-5).
- [17] Siber GR, Chang I, Baker S, Fernsten P, O'Brien KL, Santosham M, et al. Estimating the protective concentration of anti-pneumococcal capsular polysaccharide antibodies. *Vaccine* 2007;25:3816–26. <http://dx.doi.org/10.1016/j.vaccine.2007.01.119>.
- [18] Andrews NJ, Waight PA, Burbidge P, Pearce E, Roalfe L, Zancolli M, et al. Serotype-specific effectiveness and correlates of protection for the 13-valent pneumococcal conjugate vaccine: a postlicensure indirect cohort study. *Lancet Infect Dis* 2014;14:839–46. [http://dx.doi.org/10.1016/S1473-3099\(14\)70822-9](http://dx.doi.org/10.1016/S1473-3099(14)70822-9).
- [19] Principi N, Esposito S. Serological criteria and carriage measurement for evaluation of new pneumococcal vaccines. *Hum Vaccines Immunother* 2015;11:1494–500. <http://dx.doi.org/10.1080/21645515.2015.1033600>.
- [20] Goldblatt D, Hussain M, Andrews N, Ashton L, Virta C, Melegaro A, et al. Antibody responses to nasopharyngeal carriage of *Streptococcus pneumoniae* in adults: a longitudinal household study. *J Infect Dis* 2005;192:387–93. <http://dx.doi.org/10.1086/431524>.
- [21] Dagan R, Juergens C, Trammel J, Patterson S, Greenberg D, Givon-Lavi N, et al. Modeling pneumococcal nasopharyngeal acquisition as a function of antipsular serum antibody concentrations after pneumococcal conjugate vaccine administration. *Vaccine* 2016;34:4313–20. <http://dx.doi.org/10.1016/j.vaccine.2016.06.075>.
- [22] Flasche S, Van Hoek AJ, Goldblatt D, Edmunds WJ, O'Brien KL, Scott JAG, et al. The potential for reducing the number of pneumococcal conjugate vaccine doses while sustaining herd immunity in high-income countries. *PLoS Med* 2015;12:1–5. <http://dx.doi.org/10.1371/journal.pmed.1001839>.
- [23] Hammitt LL, Ojal J, Bashraheil M, Morpeth SC, Karani A, Habib A, et al. Immunogenicity, impact on carriage and reactivity of 10-valent pneumococcal non-typeable *Haemophilus influenzae* protein D conjugate vaccine in Kenyan children aged 1–4 years: a randomized controlled trial. *PLoS One* 2014;9:e85459. <http://dx.doi.org/10.1371/journal.pone.0085459>.
- [24] Chen X, Bailleux F, Desai K, Qin L, Dunning AJ. A threshold method for immunological correlates of protection. *BMC Med Res Methodol* 2013;13:29. <http://dx.doi.org/10.1186/1471-2288-13-29>.
- [25] Lipsitch M, Dykes JK, Johnson SE, Ades EW, King J, Briles DE, et al. Competition among *Streptococcus pneumoniae* for intranasal colonization in a mouse model. *Vaccine* 2000;18:2895–901.
- [26] Auranen K, Mehtälä J, Tanskanen A, S Kalltoft M. Between-strain competition in acquisition and clearance of pneumococcal carriage—epidemiologic evidence from a longitudinal study of day-care children. *Am J Epidemiol* 2010;171:169–76. <http://dx.doi.org/10.1093/aje/kwp351>.
- [27] Madhi SA, Violari A, Klugman KP, Lin G, McIntyre JA, von Gottberg A, et al. Inferior quantitative and qualitative immune responses to pneumococcal conjugate vaccine in infants with nasopharyngeal colonization by *Streptococcus pneumoniae* during the primary series of immunization. *Vaccine* 2011;29:6994–7001. <http://dx.doi.org/10.1016/j.biotechadv.2011.08.021>. *Secreted*.
- [28] Goldblatt D, Ramakrishnan M, O'Brien K. Using the impact of pneumococcal vaccines on nasopharyngeal carriage to aid licensing and vaccine implementation; a Pneumocarr meeting report March 27–28, 2012, Geneva. *Vaccine* 2013;32:146–52. <http://dx.doi.org/10.1016/j.vaccine.2013.06.040>.
- [29] Grant L, Burbidge P, Goldblatt D, Donaldson C, Weatherholtz R, Reid R, et al. Levels of antipsular IgG and protection against acquisition of pneumococcus. In: *Int. Symposium pneumococci pneumococcal dis.*, Glasgow, Scotland.; 2016.