

LONDON  
SCHOOL of  
HYGIENE  
& TROPICAL  
MEDICINE



The economics of antiretroviral therapy in  
South Africa: The role of budget impact  
modelling in changing policy

GESINE MEYER-RATH

Thesis submitted in accordance with the requirements for the degree of  
Doctor of Philosophy of the  
University of London  
OCTOBER 2015

Department of Health Services Research and Policy  
Faculty of Public Health and Policy  
LONDON SCHOOL OF HYGIENE & TROPICAL MEDICINE

No funding received

## Declaration

I, Gesine Meyer-Rath, confirm that the work presented in this thesis is my own. Where information has been derived from other sources, I confirm that this has been indicated in the thesis. Over and above the information given in the preambles for each published paper, I acknowledge the following assistance in specific parts of the thesis: Alana Brennan assisted with data analysis in producing the survival and loss-to-follow up rates and transition probabilities for adult and paediatric populations as well as the average hospitalisation frequency and length used in the National ART Cost Model (NACM). Dr Leigh Johnson calculated the number of HIV-infected adults and children and the number of adults in need of and initiating ART used in the NACM. Prof Matthew Fox conducted Empirical-Bayesian smoothing of the mortality and loss-to-follow-up rates for adult first-line treatment for the NACM and audited the model calculations. The analytical framework used in the calculation of the cost of early versus routine initiation of paediatric treatment was developed by Prof Sydney Rosen and Lawrence Long. Earlier versions of part of section 4.4 and the tables 6 to 8 in the Appendix to Chapter 4 have been published as part of a review of the state of art of modelling the cost of ART worldwide [1]; all text was written by the candidate.



Dr Gesine Meyer-Rath

## References

1. Meyer-Rath G, Over M (2012) HIV Treatment as Prevention: Modelling the Cost of Antiretroviral Treatment - State of the Art and Future Directions. PLoS Med 9(7): e1001247.  
doi:10.1371/journal.pmed.1001247

## Abstract

South Africa is home to the largest number of people living with HIV in the world, as well as the world's largest public-sector antiretroviral treatment (ART) programme. Despite the absolute majority of it being domestically funded, planning and budgeting for this programme has in the past been based on assumptions regarding target population and unit cost and on politically expedient coverage targets. The aim of this thesis was to improve on this situation by developing a budget impact model that could project the number of adults and children in treatment based on sound epidemiological methods, and calculate the cost of treating them based on the results of detailed bottom-up cost analyses at relevant clinics and hospitals in South Africa. The thesis describes the methods used in generating the inputs for the model, including the outpatient and inpatient cost of ART provision to adults and children of different ages, and the rates of CD4 cell count development, mortality, loss to follow-up, treatment failure, and regimen switches that were used in the model. The model was used to illustrate the budget impact of a number of guideline changes under discussion by the South African government in 2009/10, including 1.) expanding eligibility to all adults with CD4 cell counts <350 cells/microl, as well as to all TB co-infected and pregnant patients and all children under the age of 12 months regardless of immunological status, and 2.) replacing stavudine in first-line regimens with tenofovir for adults and with abacavir for children, with concomitant changes to second-line regimens. Both 1.) and 2.) had been suggested by the 2009 World Health Organization (WHO) guidelines ("Full WHO guidelines"). A second scenario was considered that expanded eligibility at 350 CD4 cells/microl only to those adults who were pregnant or had active TB at initiation while also replacing the current drug regimens as under 2.) ("New guidelines"). Additional factors with an impact on cost that were considered in the model were a) the introduction of a task-shifting policy that allowed antiretroviral drugs to be prescribed by nurses instead of doctors, and dispensed by pharmacy assistants instead of pharmacists, and b) replacing the existing system of antiretroviral drug procurement via government tenders that favour domestic production with drugs sourced globally at ceiling prices based on the cheapest internationally available price for each drug, including fixed-dose combinations (FDCs) wherever possible. Combining all the inputs, the model showed that while the Full WHO guidelines scenario would increase total cost over the next two mid-term expenditure framework periods (2010/11 to 2016/17) by 35% to USD 19.1 billion, and the New Guidelines scenario by 19%, this increase could be more than offset by introducing the two additional policies. In this case, the total cost of the ART programme under the New Guidelines would be 32% less than under the Old Guidelines without FDCs and task-shifting (taken as government's revealed willingness-to-pay), while reaching 14% more patients, and implementing the Full WHO Guidelines would still be 23% less costly than continuing the Old Guidelines, while reaching 23% more patients. Based in part on this analysis, the South African government increased treatment eligibility in two steps in April 2010 and in August 2011, introduced the improved drug regimens, established task shifting, and, using the proposed reference price list, negotiated significant drug price reductions for both the December 2010 and the December 2012 ARV drug tender. The budget impact model, named the National ART Cost Model, has been used in budget planning processes for the last seven financial

years and, based in part on it, the government's Conditional Grant for HIV/AIDS, the main vehicle for ART funding, was more than doubled in real terms over this time period. The thesis ends by presenting the results of a cost-benefit analysis of an alternative funding mechanism to public-sector funding, the provision of ART at the workplace, which was found from the company perspective to be cost-saving over no provision of ART, reducing the total cost due to HIV by 5%, and the cost per HIV-infected employee by 14%, over 20 years.

# Table of Contents

|   |    |
|---|----|
| Declaration   | 2  |
| Abstract .....  | 3  |
| List of Acronyms.....   | 9  |
| Acknowledgements .....  | 11 |
| 1 Introduction .....  | 14 |
| 1.1 The South African national ART programme.....   | 14 |
| 1.2 The budget process for the public-sector ART programme.....   | 15 |
| 1.3 Aim of the model .....  | 15 |
| 1.4 Policy changes between 2009 and 2011 .....  | 16 |
| 1.5 Alternatives to public sector provision of ART .....  | 18 |
| References.....   | 18 |
| 2 Background .....  | 21 |
| 2.1 Economic evaluation of healthcare programmes - principles and uses .....  | 21 |
| 2.2 Budget impact analysis in healthcare - principles and uses .....  | 22 |
| 2.3 Cost-effectiveness analysis vs. budget impact analysis: What is useful for governments? .....                         | 24 |
| 2.4 Modelling in the economic analysis of healthcare interventions.....   | 25 |
| References.....   | 27 |
| 3 Research question .....   | 29 |
| 4 Literature review: Past use of economic evaluation and budget-impact models of HIV-related interventions worldwide..... | 30 |
| 4.1 Background .....  | 30 |
| 4.2 Search strategy.....  | 32 |
| 4.3 Past budget impact analyses of HIV interventions including ART.....   | 33 |
| 4.4 Past modelled economic evaluations of antiretroviral treatment .....  | 43 |
| 4.5 The scope of economic analyses of ART in South Africa.....  | 47 |
| 4.6 Choosing an analytical framework for the budget impact analysis.....  | 48 |
| References.....   | 52 |
| Appendix to chapter 4 .....   | 59 |
| 5 Outpatient and inpatient cost of adult ART in urban and semi-urban South Africa .....                                   | 78 |
| Preamble for paper 1 .....  | 80 |
| Paper 1.....  | 81 |

|   |     |
|---|-----|
| 6 Inpatient cost of adults before and after ART .....   | 95  |
| Preamble for paper 2 .....  | 97  |
| Paper 2.....  | 98  |
| 7 Outpatient cost and outcomes of paediatric antiretroviral treatment in South Africa.....    | 111 |
| Preamble for paper 3 .....  | 113 |
| Paper 3.....  | 115 |
| 8 Outpatient and inpatient cost of early vs. deferred paediatric treatment .....              | 128 |
| 8.1 Background .....  | 128 |
| 8.2 Methods .....   | 129 |
| 8.3 Results .....   | 130 |
| 8.4 Discussion .....  | 133 |
| 8.5 Conclusion .....  | 134 |
| References.....   | 134 |
| 9 Modelling the cost of the South African national treatment programme.....                   | 135 |
| 9.1 Introduction .....  | 135 |
| 9.2 Methods .....   | 136 |
| 9.3 Results .....   | 147 |
| 9.4 Discussion.....   | 151 |
| References.....   | 153 |
| Appendix to chapter 9 .....   | 155 |
| 10 Cost benefit of workplace provision of ART .....   | 159 |
| Preamble for paper 4 .....  | 161 |
| Paper 4.....  | 162 |
| 11 Conclusions.....   | 205 |
| 11.1 Overall findings of the thesis.....  | 205 |
| 11.2 Comparison of results with those of recent economic analyses of ART in South Africa..... | 207 |
| 11.3 Contributions of the thesis .....  | 208 |
| 11.4 Limitations .....  | 211 |
| 11.5 Areas of further research .....  | 213 |
| 11.6 Policy relevance of research.....  | 214 |
| References.....   | 218 |

## List of Tables

|  |     |
|--|-----|
| Table 1: Model elements and data sources for National ART Cost Model.....                              | 51  |
| Table 2: Demographic and treatment characteristics of the two CHER trial cohorts.....                  | 130 |
| Table 3: Average resource use per child in the first year of life in the two CHER trial cohorts .....  | 131 |
| Table 4: Total cost for first year of life per child and cost per item by CHER cohort [2009 USD] ..... | 132 |
| Table 5: Summary of model elements and data sources for NACM .....                                     | 137 |
| Table 6: Scenarios of analysis .....   | 138 |
| Table 7: Assumptions regarding target population and coverage .....                                    | 140 |
| Table 8: Probabilities of death, loss to follow-up, and treatment failure (Adults).....                | 144 |
| Table 9: Assumptions regarding drug toxicity .....   | 145 |
| Table 10: Cost inputs in 2011 USD.....   | 147 |
| Table 11: Total number of patients on ART [thousands], 2010/11-2016/17 .....                           | 148 |
| Table 12: Total outpatient cost by scenario, 2010/11-2016/17 [million 2009 USD].....                   | 150 |
| Table 13: Total inpatient cost by scenario, 2010/11-2016/17 [million 2009 USD] .....                   | 151 |

## List of Figures

|   |     |
|---|-----|
| Figure 1: Health-state transition model .....   | 136 |
| Figure 2: Selected results of linear regression and Empirical-Bayes shrinkage.....      | 143 |
| Figure 3: Distribution of adult patients into antiretroviral regimens.....              | 148 |
| Figure 4: Development of HIV Conditional Grant amounts (2009/10 to 2011/12) .....       | 209 |
| Figure 5: Historic and planned government expenditure on HIV (2003/04 to 2016/17) ..... | 210 |
| Figure 6: Total government, health, HIV budgets/ expenditure (2009/10 - 2016/17) .....  | 217 |



## List of Acronyms

|            |  |
|------------|--|
| 3TC        | lamivudine   |
| ABC        | abacavir   |
| ADD        | AIDS-defining disease                                      |
| AIDS       | acquired immune deficiency syndrome                        |
| ARV        | antiretrovirals  |
| ART        | antiretroviral treatment                                   |
| ASSA       | Actuarial Society of South Africa                          |
| ASSA2003   | Actuarial Society of South Africa AIDS Model 2003          |
| AZT        | zidovudine (also abbreviated as ZDV)                       |
| BIA        | budget impact analysis                                     |
| CDC        | Centers for Disease Control and Prevention                 |
| CD4        | cluster of differentiation 4                               |
| CD4 cell   | specialised lymphocyte                                     |
| CD4%       | percentage of all lymphocytes that are CD4 cells           |
| CEA        | cost-effectiveness analysis                                |
| CHAI       | Clinton Health Access Initiative                           |
| CI         | confidence interval  |
| CHOICE     | CHOosing Interventions that are Cost Effective unit at WHO |
| CMH        | Charlotte Maxeke Hospital                                  |
| d4T        | stavudine  |
| DALY       | disability-adjusted life-year                              |
| ddC        | zalcitabine  |
| ddl        | didanosine   |
| DoH        | Department of Health                                       |
| DRV/r      | darunavir boosted with ritonavir                           |
| EFV        | efavirenz  |
| EID        | early infant diagnosis                                     |
| ESRU       | Empilweni Services and Research Unit                       |
| FDA        | US Food and Drug Administration                            |
| FDC        | fixed-dose combination                                     |
| GFATM      | Global Fund for AIDS, Tuberculosis and Malaria             |
| HAART      | highly active antiretroviral therapy                       |
| HCT        | HIV counselling and testing                                |
| HIC        | high-income country  |
| HIV        | human immunodeficiency syndrome                            |
| HSSC       | Harriet Shezi Children's Clinic                            |
| HTA        | Health technology assessment                               |
| ICER       | incremental cost-effectiveness ratio                       |
| IDV        | indinavir  |
| IQR        | inter-quartile range                                       |
| IRR        | incident rate ratio  |
| LFTU       | loss to follow-up  |
| LMIC       | low- and middle-income country                             |
| LOS        | length of stay   |
| LPV/r      | lopinavir boosted with ritonavir                           |
| LY         | life year(s)   |
| n.a. or NA | not available/ applicable                                  |
| NACM       | National ART Cost Model                                    |
| NDoH       | National Department of Health                              |

|       |  |
|-------|--|
| NGO   | non-governmental organisation              |
| NRTI  | nucleoside reverse transcriptase inhibitor |
| NSP   | National Strategic Plan                    |
| NVP   | nevirapine                                 |
| PCR   | polymerase chain reaction                  |
| PDE   | patient-day equivalent                     |
| PHCs  | primary healthcare clinics                 |
| PMTCT | prevention of mother-to-child transmission |
| pt    | patient                                    |
| pts   | patients                                   |
| QALY  | quality-adjusted life year                 |
| QoL   | quality of life                            |
| R     | South African rand                         |
| R/M   | radiometric method                         |
| RTI   | reverse transcriptase inhibitor            |
| SA    | sensitivity analysis                       |
| SANAC | South African National AIDS Council        |
| STI   | sexually transmitted infection(s)          |
| TB    | tuberculosis                               |
| TDF   | tenofovir                                  |
| TF    | treatment failure                          |
| TLC   | Themba Lethu Clinic                        |
| TWC   | Tshepong Wellness Clinic                   |
| U+E   | urea and electrolytes                      |
| USD   | US dollar                                  |
| VL    | viral load                                 |
| WHO   | World Health Organization                  |
| ZAR   | South African rand                         |
| ZDV   | zidovudine (also abbreviated as AZT)       |

## Acknowledgements

A large number of people have helped this thesis along. My main thanks goes to my supervisor, Dr Alec Miners, for offering to take over supervision at a crucial point. His support, patience and interest was pivotal in enabling me to finish this thesis. I've learned far more from him than I reckoned when I switched supervisors at the stage of data analysis. I am grateful to my original supervisor, Dr Lilani Kumaranayake, for offering to supervise me, for going far beyond her original role in acting as my agent in early attempts to finance my research, and for providing insight and inspiration in equally high doses.

I am grateful to Prof Peter Vickerman, Prof Charlotte Watts and Dr Fern Terris-Prestholt for longstanding academic and moral support. Dr Vickerman in particular taught me most of what I know about modelling and provided patience and incentive in equal measures throughout this long project. Prof Kara Hanson, Dr Arnab Acharya and Prof John Cairns provided expert research degree student co-ordination and much appreciated support. Thanks to my advisors Dr Richard Grieve, Dr Jack Dowie and Dr Philippe Mayaud for their early interest in the original version of work towards this thesis. Dr Andreia Santos and Dr Rosa Legood helped re-conceptualise some of the analysis at a crucial point in time.

The fact that I was able to finish this thesis owes much to Prof Jonathon Simon, Prof Sydney Rosen and Prof Rich Feeley at the Center for Global Health and Development at Boston University who graciously provided time for this project after I took up employment with them and allowed me to submit work resulting from my employment at Boston University towards this thesis. I am grateful for the kind support and interest of my colleagues and one-time colleagues at the Health Economics and Epidemiology Research Office in Johannesburg, especially Alana Brennan, Lawrence Long and Kathryn Schnippel. There's no-one I'd rather be discussing research with.

I am grateful for the support of a great many friends whose interest in my work helped this thesis along, in particular Ayako Honda, Grace Jennings, Markus Siegel, Gunar Guenther, Felix Roepcke, Marlise Richter, Anne Regierer, Anna Holzscheiter, and Julia Hornberger. Veronica Lillie, Michael and Jill Speed and June Fabian kindly provided accommodation and quiet that assisted in the analysis for and drafting of several of the chapters.

Staff at the Reproductive Health and HIV Research Unit at the University of the Witwatersrand (now Wits Institute for Reproductive Health and HIV) provided an intellectual home for several years and supported me in my early research and other projects for which I am very grateful, especially to Prof Francois Venter, Prof Helen Rees, Mmabatho Mqhayi, Ambereen Jaffer, Holly Fee, Winnie Moleko, Alison Jane Edge, Dr Kerrigan McCarthy and Dr Malebo Maponyane.

In addition to the people acknowledged in the published papers, I am indebted to a large number of people at different hospitals and academic institutions who assisted in data collection. Staff at clinic

556 at Charlotte Maxeke Hospital and at the Tshepong Wellness Clinic at Tshepong/ Klerksdorp Hospital Complex endured a full economic analysis to be conducted alongside their work for almost a year, and I am grateful for the patience and support they showed. My thanks go to Prof Jeffrey Wing, Sisters Onica Khumalo and Ursula Malao at Charlotte Maxeke Hospital and to Dr Ebrahim Variava and Mrs Mlambo at Tshepong Wellness Clinic, as well as all the physicians, nurses, clerks and counsellors at the clinics. At Charlotte Maxeke Hospital, I am indebted to many people for providing important information on unit and overhead costs, including Sagie Pillay, Mrs Ramothallo, Robert Matodzi, Eunice Sithole, Johannes van der Walt, Debbie Lourens, Lucky Sithole, Mrs van Schalkwyk, Lenore Terblanche, Louise Laws, Prof Debbie van der Merwe, Willie Buys, Mr Masomane, Mr Mostert, Prof Wendy Stevens, Neelen Poonen, Floyd Olsen and Alex Jennings. At the Tshepong/ Klerksdorp Hospital Complex, I am indebted to Nompoti Metsing, Dr Tsele, Erna du Plessis, Marabata Lesoge, Alpha Williams, Ms Jacobs, Martha Baarhuizen, Kido Nchang, Annalien Snyders and Mr Drosky. For help with the analysis of paediatric HIV-related cost in the first year of life I am grateful to Busisiwe Sithole and Buyiswa Ndibongo from HE<sup>2</sup>RO, Dr Avy Violari, Ravindre Panchia, Kennedy Otwombe and Handrè Truter from the Perinatal HIV Research Unit of the University of the Witwatersrand, Prof Mark Cotton of the Children's Infectious Diseases Clinical Research Unit of Stellenbosch University, Prof Ashraf Coovadia, Dr Karl Technau, Sister Annie Jordan, and Vincent Kgakgadi from the Empilweni Services and Research Unit at Rahima Moosa Mother and Child Hospital, and Prof Diana Gibb from the Clinical Trials Unit of the UK Medical Research Council. For help with the analysis of survival in care, CD4 cell count development and development of resistance and side effects in adults and children on ART that are at the centre of the National ART Cost Model I owe thanks to Alana Brennan, Lawrence Long, Prof Matthew Fox and Prof Sydney Rosen from HE<sup>2</sup>RO and the Center for Global Health and Development at Boston University as well as Dr Harrie Moultrie from the Wits Institute for Reproductive Health and HIV.

I reserve my deepest appreciation for the superior work undertaken by my four research assistants, Kgomotso Thloaele, Albertina Dambuza, Motlalepule Letsapa and Belinda Dambuza, in recruiting and interviewing the patients of the two longitudinal study cohorts at clinic 556 at Charlotte Maxeke Hospital and at the Tshepong Wellness Clinic at Tshepong/ Klerksdorp Hospital Complex, and to the many patients who agreed to be part of them and sacrificed time and offered information towards this study.

I am grateful for the early financial support of work towards this thesis by the South African Department of Health and Medical Research Council and by the World Health Organization. Dr Yogan Pillay of the South African Department of Health and Dr Mark Blecher of the South African Treasury and their teams have showed appreciation of my work and its relevance for health planning in South African throughout our longstanding interaction for which I am very grateful. It is rare for a health economist to have policy makers awaiting the results on one's analysis with such eagerness and insight.

Finally, I owe the opportunity to have learned a second trade to the support of my parents which has been invaluable in providing the space for me to be able to concentrate on this work, which was carried by their and my sister Anne's interest until the very end. I am grateful for the unwavering patience, confidence and support of my husband Steyn without which none of this would have been possible. This thesis is dedicated to our daughter Eline Margrethe.

# 1 Introduction

## 1.1 *The South African national ART programme*

South Africa is home to both the largest number of people infected with the Human Immunodeficiency Virus (HIV) as well as the largest number of patients on antiretroviral treatment (ART) in the world [1,2]. At the beginning of my work on the budget impact model presented in this thesis, in February 2010, out of a total of about 2.9 million HIV-infected citizens [3], the public-sector ART programme started in April 2004 had initiated more than 1 million patients, of whom 919,923 were reported to still be on treatment as of November 2009 [4].<sup>1</sup> In contrast to the ART programmes of other sub-Saharan countries, it was also the only one that was largely domestically funded. In 2009, 83% of total HIV funding was provided by the government [5]. By the beginning of 2009, demand for treatment had increased rapidly with over 300,000 new patients initiated per year, placing tremendous pressure on expenditure and service delivery capacity. Partly as a result, the financial year 2008/09 saw some provinces stop the initiation of new patients due to shortages of funding and staff [5].

The moratoria on treatment initiation were identified by the National Department of Health as being partly due to the lack of comprehensive planning models that allowed the estimation of ART resource use based on the number of patients currently in care, the number of patients in need of care in the future, and data on rates of death and loss from the programme, to extrapolate cost into the future. At the same time, the government, clinicians and civil society debated a range of changes to the national ART guidelines, all of which would have considerable implications for the cost of the programme. As a result, in April 2009, the South African National Department of Health created a task team to calculate the resources required for national ART provision between the financial years 2009/10 and 2016/17.

The proposed changes to the national ART guidelines included adopting the World Health Organization's (WHO) updated ART guidelines for resource-limited settings that were under discussion at the time and were released in early 2010 [6]. These increased the immunological threshold for eligibility from <200 CD4 cells/microl to <350 CD4 cells/microl and replaced stavudine (d4T) with tenofovir (TDF) in first-line ART for newly initiated adults. Proposed changes to the paediatric ART guidelines included initiating on treatment all children <12 months who tested positive by HIV PCR (Early Paediatric Treatment), regardless of clinical or immunological status, and the replacement of stavudine with abacavir (ABC) in first-line regimens for newly initiated children. Other changes the task team considered were task-shifting from doctors to nurses and from pharmacists to pharmacy assistants, and replacing the existing system of antiretroviral drug procurement via

---

<sup>1</sup> In the interim, both the total number of HIV-infected South Africans and those on ART have increased several-fold. For 2014, UNAIDS estimated that there were 6.8 million people living with HIV in South Africa, out of which 6.5 million (96%) were adults. The country was experiencing 340,000 new cases of HIV in 2014 (52% of which were amongst adult women), representing an adult incidence rate of 1.27. AIDS-related deaths were estimated at 140,000 in the same year [2].

government tenders that favoured domestic production with drugs sourced globally at ceiling prices based on the cheapest internationally available price for each drug.

To help the Department of Health assess the likely effect of these changes on ART programme costs and to improve the accuracy of national HIV/AIDS budget projections, a health-state transition model was developed that combined primary data on patient costs and outcomes with existing national projections of numbers of patients in need of and initiating care. The model (called the National ART Cost Model, NACM) allowed the Department to estimate current and future budgetary needs, assess proposed treatment guideline changes, and calibrate programme expansion to financial resources.

## ***1.2 The budget process for the public-sector ART programme***

In South Africa, the public-sector antiretroviral treatment programme is implemented at the level of the nine provinces and funded via two mechanisms: the HIV/AIDS Conditional Grant from the National Treasury that pays for antiretroviral drugs, all laboratory tests that are ordered out of ART clinics, and a share of the staff time at the clinic. The second mechanism is the province's general share of national revenue, called the Equitable Share, which is meant to cover all remaining outpatient expenditure, i. e., the remaining staff costs, buildings and other overheads [7]. These budget items cover the outpatient expenditure for ART provision only; inpatient care for patients on ART is paid for by the general Hospital Grant [7].

Until early 2009 the annual conditional grant budgets that were submitted by the National Department of Health (NDoH) to Treasury were principally based on provincial plans that contained almost no analysis. As a result, the process of setting a budget for the ART programme at the national level was based on targets and unit costs set by provinces which in turn were most often based on past budgets or assumptions. A notable exception was the National Strategic Plan for HIV and AIDS & STIs 2007-2011 which marked a turn-around in the national HIV policy away from decades of underestimation and several years of outright denial of the problem. This plan contained a detailed analysis of the cost of most interventions contained in the plan that was based on population data produced by epidemiological models, unit costs based on cost analyses, and coverage targets agreed on by policy makers [8]. It did not, however, change the budgeting process for HIV or ART in South Africa.

## ***1.3 Aim of the model***

As will be discussed in section 4.5, owing to its size and the contested nature of its policy foundation during the early years, the South African ART programme has been subjected to more economic scrutiny than any other ART programme outside the United States [9-20]. Again because of its prominent nature, together with the availability of good outcomes and cost data, the programme has furthermore been used as a case in point for a growing body of more extensive economic analyses of

various changes to ART eligibility [21-27] and monitoring strategies [28] for other countries as well as globally, often using extensive modelling techniques.

The model developed in this thesis, the National ART Cost Model (NACM), differs from these economic analyses of the South African ART programme in a number of important aspects. Firstly, and most importantly, in contrast to the previous analyses it is a national-level budget impact model, which means the analytical framework is dictated by the exact budget items it will inform. In contrast to the other analyses that reported the cost of some of these budget items only or aimed at shaping global decision around antiretroviral treatment provision, the NACM aims at producing cost projections relevant to the South African public-sector payer and budget process, using the best available local data regarding numbers in need of ART, on ART, and cost. Since it is a budget impact model, the NACM's projection period is eight years only, spanning two mid-term expenditure framework terms, the relevant planning unit for public finance in South Africa; its outcomes are numbers of people on treatment and cost only, instead of life-years gained or utility; and most importantly, it is limited to calculating the part of the cost of the programme that is relevant to the ART budget. The model calculates the required size of both the HIV/AIDS conditional grant and the contribution from the equitable share, and has an option to also calculate the share of the hospital budget that will be required for the inpatient care of patients on ART, but does not include costs above the clinic or hospital level that are associated with ART provision (as these are covered under separate budgets) or costs accrued by HIV-positive patients not on ART, beyond costs required for the preparation of a patient about to initiate ART. Secondly, in contrast to most other published studies that use a multitude of data sources, both cost and cohort data (such as mortality, loss, and treatment failure rates as well as transition probabilities between CD4 cell count-defined health states) were generated in the same two clinics, supporting the notion that the resources used in the model in fact contributed to the outcomes used in the model- Themba Lethu Clinic at Helen Joseph Hospital for adult data and Harriet Shezi Clinic at Chris Hani Baragwanath Hospital for paediatric data.

This thesis describes the characteristics and uses of the National ART Cost Model and presents the research used to estimate a number of the inputs used in the model. These inputs include the outpatient and inpatient cost of ART provision to adults and children as well as survival, retention in care and CD4 cell count development of the clinic cohorts used in the parameterisation of the model. It finishes with an analysis of an alternative funding model to public-sector provision, ART programmes at the workplace level paid for by private-sector companies.

#### ***1.4 Policy changes between 2009 and 2011***

In late 2009, the results of the model were among the factors that led the South African Government to revise its treatment guidelines and nearly double the budget allocation for ART [29,30]. The new guidelines included an increase in the adult eligibility threshold to 350 CD4 cells/microl for patients with tuberculosis and pregnant patients, early paediatric treatment of infants under 1 year of age, and



the replacement of the first-line drug d4T by TDF for adults and by ABC for children, thus bringing the South African guidelines closer to the 2010 WHO guidelines. These changes were announced by the South African president, Jacob Zuma, in a speech on World AIDS Day 2009, and the budget for the HIV/AIDS Conditional Grant was increased by R8.4 billion (USD 1.2 billion) or 87.9% between 2009/10 and 2012/13 [31].

In order to cope with the projected increase in patients on ART as a result of these new guidelines, the number of public-sector clinics accredited to provide ART was increased from 497 in December 2009 to 814 by July 2010 [32] and to 2,205 by May 2011 [33]- a more than 5-fold increase in a mere 18 months. At the same time, task-shifting from doctors to nurses was implemented, and by May 2011, 2,000 nurses had been trained to initiate and manage ART [33], thereby implementing one of the recommendations of our research for improving technical and economic efficiencies. The second suggested measure, the opening of the 4-yearly tender process for antiretrovirals to international bidders, was implemented for the ARV tender negotiated in December 2010 and led to a reduction of the per-drug cost by an average of 53% [33], a reduction in the cost of the standard first-line regimen for adults of 32% [34], and a reduction in the projected annual cost of the ART programme by 25% to 26% [34]. Lastly, in April 2010 the Government embarked on a country-wide HIV counseling and testing (HCT) campaign which succeeded in counseling 14 million South Africans, and testing 12 million of them, over 15 months, during which 2 million people were found to be HIV positive and were referred for further care [33].

As a result of these changes, by the middle of 2011, the number of patients receiving ART in South Africa was estimated at 1.79 million out of a total of 3.1 million HIV-positive people, with adult ART coverage having increased to 79% under the old eligibility criterion ( $CD4 < 200$  cells/microl), or 52% under the eligibility criterion of the 2010 WHO guidelines ( $CD4 < 350$  cells/microl) [3].

In August 2011, again based in part on the model projections, the adult guidelines were revised a second time, to now increase the eligibility threshold to 350 CD4 cells/microl for all adults. This last step meant that within less than two years the 2010 WHO ART guidelines had been fully implemented [35]. The National Strategic Plan on HIV, STIs and TB 2012-2016 which was issued by the South African National AIDS Council in December 2011 then extended adult eligibility further to include pregnant patients and patients with TB regardless of CD4 cell count [36]. Because coverage of children with ART was lagging behind adult coverage, additional resources were committed to Early Infant Diagnosis with PCR, and in August 2012 the age of eligibility for immediate treatment regardless of CD4% or clinical status was progressively raised to encompass all children aged below six years [37].

Beyond enabling decision makers in the South African government to commit to guideline and other programmatic changes, the model also improved the budgeting process for ART more generally, by allowing the national Department of Health in particular to scrutinise budget submissions from

provinces and motion for budget increases from Treasury based on real data. This aspect will be discussed in more detail in section 11.3.

### ***1.5 Alternatives to public sector provision of ART***

Despite early commitments by the South African National AIDS Council and the South African Business Coalition on HIV/AIDS to involve the private sector in the roll-out of ART, the private sector has been slow to implement HIV care. In November 2009, between 51,633 and 86,000 patients were reported to be on ART through private sector programmes such as workplace treatment programmes and disease management providers - less than 10% of the public-sector treatment cohort [4]. According to the National AIDS Spending Assessment conducted for 2008/09, the private sector contributed about 8.5% of the country's total HIV expenditure [38]. In 2006, an analysis of 53 companies with more than 6,000 employees in South Africa showed that while availability of treatment was high, uptake was low, with only 27% of HIV-positive patients enrolled in any kind of disease management programme [39]. The 2012-16 National Strategic Plan set out to address the "inadequate co-ordination of public sector, private sector and non-governmental sector responses" and called on all employers to ensure that employees had access to testing, prevention, pre-ART ("wellness") care and treatment, with special attention given to high-risk workplaces such as mines [36].

Among the possible alternatives to public-sector funding of ART provision, workplace provision stands out in that businesses, by offsetting absenteeism and high labour turnover due to HIV, have a potential to reap positive financial returns from a treatment programme. A synthesis of work on the impact of HIV prevalence and ART on companies of different sizes in sub-Saharan Africa reported that ART at a cost of USD 360/ year (in 2006 terms) was cost-saving for most larger companies, depending on HIV prevalence, the skill level of the employees and existing employment and benefit policies [40]. Very few analyses quantified the impact of ART on a single workforce, and none of them had been conducted in South Africa [41,42].

The final section of the thesis reports on a cost-benefit analysis of an antiretroviral treatment programme supplied by a coal mining company in South Africa and discusses the impact of extending it to all HIV-infected employees and to the miners' families, respectively. It is the first full cost-benefit analysis of ART provision at the workplace of any country that includes not only the impact on worker absenteeism and productivity but also healthcare costs and is based on primary data.

### ***References***

1. UNAIDS: AIDS epidemic update December 2009. Geneva 2009
2. UNAIDS Aidsinfo. Accessed under [aidsinfo.unaids.org](http://aidsinfo.unaids.org). Last accessed 28 July 2015.
3. Johnson LF: Access to Antiretroviral Treatment in South Africa, 2004-2011. *South Afr J HIV Med* 13(10):22-27.

4. Republic of South Africa (2010) Country Progress Report on the Declaration of Commitment on HIV/AIDS. 2010 Report
5. AIDS Law Project: Submission on the Division of Revenue Bill, 2010.
6. World Health Organization: Rapid advice: antiretroviral therapy for HIV infection in adults and adolescents. Geneva 2009
7. Karume J, Ndlovu N, Meyer-Rath G: Understanding the financing of HIV/AIDS in the public sector of South Africa. HE<sup>2</sup>RO Policy Brief Number 9, Health Economics and Epidemiology Research Office, 2014.
8. Cleary S: The costs of the National Strategic Plan on HIV and AIDS & STIs 2007-2011. Pretoria 2007
9. Rosen S, Long L, Fox M, Sanne I: Cost and cost-effectiveness of switching from stavudine to tenofovir in first-line antiretroviral regimens in South Africa. *J Acquir Immune Defic Syndr* 2008;48(3):334-44.
10. Rosen S, Long L, Sanne I: The outcomes and outpatient costs of different models of antiretroviral treatment delivery in South Africa. *Trop Med Int Health* 2008;13(8):1005-15
11. Long L, Fox M, Sanne I, Rosen S: The high cost of second-line antiretroviral therapy for HIV/AIDS in South Africa. *AIDS* 2010,24(6):915-9
12. Leisegang R, Cleary S, Hislop M, et al: Early and late direct costs in a Southern African antiretroviral treatment programme: A retrospective cohort analysis. *PLoS Med* 2009 6(12)
13. Badri M, Cleary S, Maartens G, et al: When to initiate highly active antiretroviral therapy in sub-Saharan Africa? A South African cost-effectiveness study. *Antivir Ther* 2006;11(1):63-72
14. Cleary S, McIntyre D, Boule A: The cost-effectiveness of antiretroviral treatment in Khayelitsha, South Africa - a primary data analysis. *Cost Effect Res All.* 2006;4:20.
15. Harling G, Wood R: The evolving cost of HIV in South Africa. *JAIDS* 2007;45:348-54.
16. Martinson N, Mohapi L, Bakos D, et al. Costs of providing care for HIV-infected adults in an urban HIV clinic in Soweto, South Africa. *JAIDS* 2009;50: 327-30
17. Stearns BK, Evans DK, Lutung P, et al. Primary estimates of the costs of ART care at 5 AHF clinics in sub-Saharan Africa [MOPE0706]. Presented at: XVIIth International AIDS Conference; 2008; Mexico City.
18. Kevany S, Meintjes G, Rebe K, et al: Clinical And Financial Burdens of Secondary Level Care In A Public Sector Antiretroviral Roll-out Setting (G F Jooste Hospital). *S Afr Med J.* 2009;99:320-25.
19. Smith de Cherif TK, Schoeman JH, Cleary S, et al: Early severe morbidity and resource utilization in South African adults on antiretroviral therapy. *BMC Inf Dis* 2009;9:205.
20. Thomas LS, Manning A, Holmes CB, et al: Comparative Costs of Inpatient Care for HIV-Infected and Uninfected Children and Adults in Soweto, South Africa. *JAIDS* 2007;46:410-6.
21. Granich RM, Gilks CF, Dye C, De Cock KM, Williams BG: Universal voluntary HIV testing with immediate antiretroviral therapy as a strategy for elimination of HIV transmission: a mathematical model. *Lancet* 2009;373(9657):48-57
22. Walensky RP, Wolf LL, Wood R et al for the CEPAC (Cost-Effectiveness of Preventing AIDS Complications)-International Investigators: When to Start Antiretroviral Therapy in Resource-Limited Settings. *Ann Int Med* 2009;151:157-166
23. Walensky RP, Wood R, Ciaranello AL, Paltiel AD, Lorenzana SB, Anglaret X, et al for the CEPAC-International Investigators: Scaling Up the 2010 World Health Organization HIV Treatment Guidelines in Resource-Limited Settings: A Model-Based Analysis. *PLoS Med* 2010;7(12): e1000382. doi:10.1371/journal.pmed.1000382
24. Bendavid E, Grant P, Talbot A, Owens DK, Zolopa A (2011) Cost-effectiveness of antiretroviral regimens in the World Health Organization's treatment guidelines: a South African analysis. *AIDS* 25: 211–220.
25. Ciaranello AL, Lockman S, Freedberg KA, Hughes M, Chu J, et al (2011) First-line antiretroviral therapy after single-dose nevirapine exposure in South Africa: a cost-effectiveness analysis of the OCTANE trial. *AIDS* 25:479–492.

26. Bachmann MO (2006) Effectiveness and cost effectiveness of early and late prevention of HIV/AIDS progression with antiretrovirals or antibiotics in Southern African adults. *AIDS Care* 18(2): 109-120.
27. Hontelez JAC, de Vlas SJ, Tanser F, Bakker R, Bärnighausen T, et al (2011) The Impact of the New WHO Antiretroviral Treatment Guidelines on HIV Epidemic Dynamics and Cost in South Africa. *PLoS ONE* 6:e21919.
28. Vijayaraghavan A, Efrusy MB, Mazonson PD, Ebrahim O, Sanne IM, et al (2007) Cost effectiveness of alternative strategies for initiating and monitoring highly active antiretroviral therapy in the developing world. *J Acquir Immune Defic Syndr* 46(1): 91-100.
29. National Department of Health, Republic of South Africa (2010) Clinical Guidelines for the Management of HIV & AIDS in Adults and Adolescents
30. National Department of Health, Republic of South Africa (2010) Guidelines for the Management of HIV in Children
31. Ndlovu N, Sithole F, Vilakazi M, Mbatha K, Guthrie T: CEGAA TAC Joint Statement: A story of hope on national HIV and AIDS policy and funding in South Africa. Available under [www.tac.org.za/community/node/2815](http://www.tac.org.za/community/node/2815), accessed 24 Nov 2010.
32. Speech by Minister of Health Dr Aaron Motsoaledi, on occasion of XVIII International AIDS Conference, Vienna. 20/7/10. Available under [www.cabsa.org.za/content/speech-minister-health-dr-aaron-motsoaledion-occasion-xviii-international-aids-conference-vi](http://www.cabsa.org.za/content/speech-minister-health-dr-aaron-motsoaledion-occasion-xviii-international-aids-conference-vi), accessed 5 Jan 2011.
33. Health Budget Vote Policy Speech presented at the National Assembly by Minister of Health, Dr A Motsoaledi. Available under [www.info.gov.za/speech/DynamicAction?pageid=461&sid=18751&tid=34232](http://www.info.gov.za/speech/DynamicAction?pageid=461&sid=18751&tid=34232), accessed 8 July 2011.
34. Meyer-Rath G, Pillay Y, Blecher M, Brennan A, Long L, Johnson LF, Moultrie H, Sanne I, Fox M, Rosen S: The impact of a new reference price list mechanism for drugs on the total cost of the national antiretroviral treatment programme in South Africa 2011 to 2017. Abstract no. 621 (oral presentation), South African AIDS Conference 2011
35. Statement on the meeting of the South African National AIDS Council (SANAC), 12 August 2011
36. South African National Council: National Strategic Plan on HIV, STIs and TB 2012-2016. Pretoria, December 2011
37. National Department of Health, Republic of South Africa: Initiation of antiretroviral treatment (ART) to all HIV positive children aged 5 or under regardless of CD4 count and/ or clinical staging. Circular Minute No. 2 of 2012.
38. Centre for Economic Governance and AIDS/ South African National AIDS Council: South Africa's National Aids Spending Assessment Brief (2007/08--2009/10). Pretoria, April 2013
39. Connelly P, Rosen S: Treatment for HIV/AIDS at South Africa's largest employers: myth and reality. *S Afr Med J* 2006; 96: 128-133.
40. Rosen S, Feeley F, Connelly P, Simon J: The private sector and HIV/AIDS in Africa: taking stock of 6 years of applied research. *AIDS* 2007, 21 (suppl 3):S41-S51
41. Larson BA, Fox MP, Rosen S, Bii M, Sigei C, Shaffer D, Sawe F, Wasunna M, Simon JL: Early effects of antiretroviral therapy on work performance: preliminary results from a cohort study of Kenyan agricultural workers. *AIDS* 2008, 22:421-425
42. Larson BA, Fox MP, Rosen S, Bii M, Sigei C, Shaffer D, Sawe F, K McCoy, Wasunna M, Simon JL: Do the socioeconomic impacts of antiretroviral therapy vary by gender? A longitudinal study of Kenyan agricultural worker employment outcomes. *BMC Public Health* 2009, 9:240

## 2 Background

### ***2.1 Economic evaluation of healthcare programmes - principles and uses***

Economic evaluation of health interventions consists of a suite of methods that allow the comparison of the costs and outcomes of medical interventions in order to make decisions in a situation of resource constraint [1], effectively providing answers in a situation in which healthcare is an economic good for which resources are limited while the possible uses for these resources are unbound [2]. Importantly, cost in this sense is not the result of an accounting procedure, but the value of the benefit that was forgone by not choosing the next best alternative - in other words, cost in economic evaluation is defined as opportunity cost [2]. Economic evaluation helps policy makers gain maximum benefits from a given level of resources, or minimise the cost to achieve a desired level of benefit, by improving the technical and/ or economic efficiency of existing practices, both when planning new interventions and when expanding existing ones.

A full economic analysis of a healthcare intervention always includes costs as well as consequences and compares two or more alternatives. It can take one of three different forms [3]:

1. Cost-effectiveness analysis, which compares the cost of an intervention with its effects, where the outcome is either a process or intermediary health indicator or a final health outcome such as life years (LY) gained.
2. Cost-utility analysis, which compares the cost of an intervention with its outcome valued using health-state preferences. Results are often presented as cost per quality-adjusted life year (QALY) gained or cost-per disability-adjusted life year (DALY) averted.
3. Cost-benefit analysis, which compares the cost of an intervention with its outcome valued in monetary terms, often in terms of the willingness-to-pay of a group of individuals or society as a whole.

Cost-benefit analysis (CBA) is the original and most comprehensive of the techniques discussed above. In its purest form, a CBA evaluates as wide a range of health and other consequences of a new intervention as possible and compares these with the required resources in a form of compensation test- that is, whether those who gain from the new intervention could theoretically compensate those who lose due to it, and still end up in a preferred position [1,4]. It is also the only type of economic evaluation that allows the consideration of the value created by a healthcare programme that is not directly linked to changes in health, such as receiving additional information or reassurance. In keeping with its welfarist foundations, the perspective from which the analysis is conducted and which defines which costs and benefits to include is that of society as a whole. Under specific circumstances, such as when the payer for a healthcare programme is clearly defined and reaps all or most of the benefits from the programme, the perspective can be changed to be that of the particular payer (i.e., a government, an individual or a company). The decision rule based on the results of CBAs is simple: if the sum of the benefits of an intervention is greater than the sum of its

costs (in other words, if the net benefit, the difference between benefits and costs, is positive), it should be undertaken on the grounds of efficiency [2].

A cost-effectiveness analysis (CEA) extends the notion of welfarism by allowing for an exogenously defined societal objective in terms of maximising health, and an exogenously set budget constraint for healthcare, a concept that has been called “extra welfarism” [5], or social decision making [1]. In other words, while CBA can be used to determine the overall budget in line with the most efficient resource allocation between interventions, CEA can be used to allocate resources most efficiently *after* the overall budget has been allocated to a particular intervention [6]. The decision rule resulting from this is that an intervention is cost effective if its cost per defined outcome is lower than a pre-defined threshold signifying the willingness-to-pay of the relevant payer (which can be a government, society, an individual or a company). As in a CBA, this payer also defines the perspective that the analysis takes.

Cost-utility analysis extends the notion of the societal objective in terms of maximising health by adding an explicit valuation of utility to it; as a result, it is for example able to compare the resources spent on an intervention or policy option with its impact not only on length but also on quality of life. Utility, or quality weights, can be elicited from society as a whole, healthcare providers, or patients, each of which will result in different values. The same decision rule as for CEA applies, though the willingness-to-pay threshold will be different.

## ***2.2 Budget impact analysis in healthcare - principles and uses***

Budget impact analysis (BIA) is an evaluation of the financial consequences arising from a reimbursement decision regarding a healthcare technology, intervention or programme in a specific healthcare setting [8]. In contrast to the normative framework of a full economic evaluation which allows policy makers to prioritise between interventions by comparing the relative cost of implementing a new intervention or scaling up an existing one with the relative outcomes of the intervention, a budget impact analysis focuses on the costs and use of other resources by an intervention and its alternatives only, leaving out all considerations of outcomes, and as such allows policy makers to decide on an intervention’s affordability and sustainability [9]. While an economic evaluation seeks to include all benefits from an intervention, potentially requiring a societal perspective and modelling over the lifetime of the patient cohort in question, a BIA is typically conducted from the perspective of the relevant payer (which can be the government or any other funder or funders, such as reimbursement agencies), and its timeframe is defined by this payer’s planning and budgeting cycles [9].

BIAs are now part of the standard requirement for submissions to a number of national regulatory agencies, such as the National Institute for Clinical Excellence (NICE) in England and Wales and the Pharmaceutical Benefits Advisory Committee (PBAC) in Australia, as well as several managed care

organisations in the US [9]; however, the degree to which the information on budget impact informs the decisions of these regulators differs. Generally, it is important to note that decisions on whether or not a specific healthcare intervention will be funded will depend mostly on the robustness of evidence on effects and cost-effectiveness of an intervention, while the BIA's role is mostly in aiding planning and budgeting for the intervention once a decision to fund it has been made [10]. Thus, a BIA tends to supply secondary information regarding affordability and, potentially, sustainability to supplement the primary information regarding value added that is conveyed in an economic evaluation [7].

BIA was introduced into the health economic literature by Mauskopf in 1998 [11] as a complement to standard economic evaluations. She proposed that a full economic assessment of a new drug should include a CEA in order to establish product efficiency and value from a societal perspective, as well as a BIA to determine affordability as well as the impact on service use and population health from a national health insurance perspective [11]. Since then, a number of national and international guidelines have been issued that describe principles of good practice for the execution of BIAs [8-10,12-14].

In 2007, the International Society for Pharmacoeconomics and Outcomes Research (ISPOR) published the report of a task force that had been formed to issue good research practices for modellers and end users of BIAs [8]. One focus of the recommendations was that the perspective of the specific healthcare decision maker was paramount in selecting data on the target population for a health intervention, the current and expected new treatment mix, and the relevant resource use and costs. Additionally, scenario analysis representing alternatives of relevance for the decision-maker should be added, similar to sensitivity analyses in CEAs. Another recommendation was that the simplest possible analytical framework that would produce transparent, valid estimates should be chosen; though that if a health-state transition model was needed, all possible health outcomes, together with their cost, for the total population affected by the intervention should be included [8]. Finally, a recommendation was made to present the resulting costs undiscounted since these reflect financial streams over time, but to leave the framework open for the decision maker to add discounting if the need arose, using local practice [8].

In 2014, the same organisation convened another task force to update these recommendations. Concerns regarding potential access restrictions, the anticipated uptake, and the use and effects of the new interventions as well as current interventions that might be replaced by them were added. In terms of methods, again simplicity was paramount, with a specific recommendation for a simple spreadsheet-based cost calculator approach unless anticipated changes in the target population, disease severity mix or treatment pattern would call for a condition-specific cohort or patient simulation model. In terms of uncertainty analysis, the recommendations limit it to parameter uncertainty of the input values and structural uncertainty in the choice of the analytical framework. Since data for a new intervention is often limited, standard approaches such as one-way and stochastic analysis can often not be carried out meaningfully, in which case the task force

recommended scenario analysis taking into account plausible alternative input parameter values and structural assumptions. Finally, a recommendation for validation of the computing framework and input data was added, including, at the least, a check for face validity with the decision makers and the verification of calculations [10].

In a review of existing BIA guidelines, including the first of the ISPOR guidelines, in 2011 Garattini and van de Vooren summarised the existing national and international recommendations at the time to generate a single definition of a state-of-the-art BIA: a “BIA should be defined as an EE [economic evaluation] conducted: (1) according to the budget holders’ perspective; (2) with a short TH [time horizon] (<3 years) and within a clearly specified setting; (3) where results are expressed as undiscounted cost differences between the new scenario (including the new technology) and the current/ reference scenario; (4) taking account of the potential trade-offs in healthcare resources induced by the effectiveness of the new technology, and (5) examining the results using SA [sensitivity analysis] responsive to the uncertainty surrounding future market developments (like scenario analysis), and easy to understand by budget holders (like the analysis of extremes)” [7]. To this one could add that rather than restricting the time horizon for the analysis to an arbitrary 3 years, this, as the rest of the analytical framework, should be defined by the planning horizon of the payer whose perspective the BIA takes, be this a budget cycle, a government tender period, or similar.

In South Africa, guidance on economic analyses, including budget impact analyses, for priority setting in the public sector is lacking. Since 2013 the country has had a set of guidelines for pharmaco-economic analyses that guides submissions to the Pricing Committee of the directorate for Pharmaceutical Economic Evaluations of the National Department of Health [15]. While these guidelines are very detailed in their description of the required aspects of such analyses, including modelling methods, they currently apply to submissions for the private sector only, and do not give any details on budget impact analyses [15].

### ***2.3 Cost-effectiveness analysis vs. budget impact analysis: What is useful for governments?***

Trueman et al in 2001 defined the BIA as an analysis that “falls somewhere between a simple 1-year accounting model and the costing side of an economic evaluation from a societal point of view” [8]. Despite the fact that BIA is a somewhat simpler and restricted method than an economic evaluation, in our experience it has an important role to play in allowing a government that has made up its mind about its priorities to decide on the exact strategy for initiating or increasing coverage with a new programme and commit the necessary resources. The answer a BIA gives might be simple, but often it is exactly the answer to the question that a government has asked.

The notion of policy makers at national government level prioritising information on affordability over information regarding cost-effectiveness is borne out by recent reviews of the criteria used in



healthcare priority setting by decision-makers around the world. A review of 40 papers describing either surveys amongst policy makers or tools used in priority-setting found that criteria relating to cost, budget impact, or financial impact were mentioned as relevant 29 times, while cost effectiveness was mentioned 23 times [16]. Likewise, a review of 36 studies concluded that cost effectiveness had limited influence on healthcare decision-making at different political levels [17]. Garattini and van de Vooren argue that it is exactly the preference for complexity that is inherent in an economic evaluation - and more especially a cost-effectiveness analysis -, such as a societal perspective and a time horizon that includes all potential benefits of a new intervention or technology, that makes the results unwieldy for decision makers and has given rise to the popularity of BIAs for budget holders [7].

As mentioned in chapter 1, because of its size and its ability to generate and record relevant data, by 2009 the South African public-sector ART programme had already been subjected to a large number of economic analyses, including cost analyses, cost-utility and cost-effectiveness analyses. A number of analyses had furthermore sought to extrapolate from South African data to answer questions about the relative cost effectiveness of increases in eligibility and of treatment for HIV prevention for low- and middle-income countries generally. An important finding from our work with the South African Department of Health and Treasury was that the final decision to change the national antiretroviral treatment guidelines in order to increase eligibility and provide better drugs was not made based on criteria of cost effectiveness but on criteria of affordability. It stands to reason however that some or all of the numerous cost-effectiveness analyses that had been conducted previously were important in preparing this decision, in particular two analyses of the cost effectiveness of replacing d4T by TDF in the first-line regimen for adults [18] and of increasing the eligibility threshold from 200 to 350 CD4 cells/microl [19].

Be this as it may, in 2009, the South African government, after having answered the question “Is an expansion of the ART programme a good investment?” in the affirmative, needed an answer to the question “What will it cost compared to the planned health budget?”. This type of question could only be answered by a budget impact analysis.

## ***2.4 Modelling in the economic analysis of healthcare interventions***

In both economic evaluations and budget impact analyses, mathematical models are used as a means of extrapolating data from a clinical trial or the literature in a way that goes beyond the original setting of the trial or study, both in terms of time period as well as populations covered. As the review of existing literature on budget impact analyses of HIV interventions in Chapter 4 will show, it would have been impossible to calculate the cost and budget impact of ART provision under a number of different eligibility scenarios and combinations of drug regimens for a national-level cohort comprising both adults and children without taking respite to a detailed mathematical model. Despite the differences in purpose and design mentioned above, much of the structure of such a model will be

similar between an economic evaluation and a budget impact analysis, so the principles informing the choice of this structure are reviewed together here.

In general, models used in the economic evaluations and budget impact analyses of healthcare interventions consist of a set of mathematical operations that structure the extrapolation of an intervention's effects and cost over time [1] and allow linking observable intermediate endpoints (for example, a CD4 cell count) to final endpoints (for example, HIV disease progression or survival) [2]. Models can be used whenever input data from more than one source have to be synthesised in a meaningful way, allowing the analyst to deal with uncertainty arising from these different sources systematically [2].

Standard literature on the methodology of models used for economic analysis in healthcare settings suggest that the analytical framework should incorporate the following aspects [1,2,3]:

1. Consideration of all relevant scenarios for comparison that could be used in practice, including, where appropriate, a “do nothing” scenario;
2. A framework for evidence synthesis that incorporates all relevant evidence;
3. An appropriate time horizon that is able to capture the relevant differences in cost and/ or outcomes between the scenarios;
4. An explicit treatment of uncertainty in both the observed data and techniques used in their extrapolation which allows the user of the model results to see how uncertainty in the evidence translates into uncertainty surrounding the decision.

While models are primarily a means of expanding the knowledge generated by other forms of research beyond the limits of the observed, they also bear the risk of adding uncertainty, especially in terms of parameter uncertainty in the data points chosen and in terms of structural uncertainty in terms of the choice of analytical framework. Another source of bias lies in the nature of the extrapolation, where outcome data is often based on surrogate markers requiring additional assumptions regarding the relationship between the observed marker and the outcome. The use of uncertainty analysis or, in the case of models used for BIA, scenario analysis is therefore paramount.

A number of different techniques have been devised over the last decades for use in modelling healthcare interventions. An important distinction between these methods is whether their inputs are based on data from single patients (microsimulation models) or on cohort averages and their ranges (decision trees and health-state transition models). Cohort-based models often follow groups of people through a series of mutually exclusive and collectively exhaustive health states that together fully describe the course of a disease. Health states are meant to be differentiated from each other by important differences in terms of either the outcomes (eg, probability of survival) or the cost attached to the categories used to describe them, or both. Decision trees are organised in such a way that movements between health states follow a fixed sequence and each health state can be occupied only once by a group of individuals, while health-state transition models typically allow groups of

individuals to revisit health states and are often run until all individuals have entered into an absorbing state from which there is no exit (most often the “Dead” state). Another important difference between decision trees and health-state transition models is the use of time - in decision trees, time is often not explicitly defined and is mostly relevant for defining the sequence of events; health-state transition models on the other hand evaluate the evolution of health states over defined time periods, called model cycles [2].

In both types of models, transitions between health states depend on a set of transition probabilities that are conditioned on the characteristics of the current health state, and costs get accumulated along the path a group of individuals take through the model. The most frequently used type of health-state transition models are Markov models in which transition probabilities often are characterised by two additional criteria: firstly, the “Markovian assumption” of zero memory which defines that transition probabilities can only ever be conditional on the last health state, and all “memory” of previous events is lost; and secondly, the time homogeneity of transition probabilities, in which all probabilities apply to the same length of time (called a model cycle, defined as a time period relevant for the disease or intervention in question).

A second important distinction between types of disease models is whether they are solved using deterministic or stochastic methods. While microsimulation models tend to be stochastic models that are evaluated using between ten thousands to millions of model runs, for decision trees and health-state transition models, this choice is open to the analyst.

## **References**

1. Briggs, Claxton, Sculpher 2006: Briggs A, Claxton K, Sculpher M: *Decision Modelling for Health Economic Evaluation*. Oxford: Oxford University Press (2006)
2. Morris S, Devlin N, Parkin D: *Economic Analysis in Health Care*. Chichester: John Wiley & Sons (2007)
3. Drummond M, O'Brien B, Stoddart G, Torrance G, *Methods for the economic evaluation of health care programmes*. 3rd ed. 2005, New York: Oxford University Press.
4. Sudgen and Williams 1978: Sudgen R, Williams A: *The Principles of Practical Cost-Benefit Analysis*. Oxford: Oxford University Press (1978)
5. Culyer 1989: Culyer AJ: The normative economics of health care finance and provision. *Oxford Rev Econ Policy* 1989;5:34-68
6. Mishan E: *Cost-benefit analysis*. Sydney: Allen and Unwin (1971)
7. Garattini L, van de Vooren K: Budget impact analysis in economic evaluation: a proposal for a clearer definition. *Eur J Health Econ* 2011;12:499–502
8. Trueman P, Drummond M, Hutton J. Developing guidance for budget impact analysis. *Pharmacoeconomics* 2001; 19(6): 609-621.

9. Mauskopf JA, Sullivan SD, Annemans L, Caro J, Mullins CD, Nuijten M, PhD, Orlewska E, Watkins J, Trueman T: Principles of Good Practice for Budget Impact Analysis: Report of the ISPOR Task Force on Good Research Practices - Budget Impact Analysis. *Value Health* 10(5):336-347 (2007)
10. IQWiG (Institut für Qualität und Wirtschaftlichkeit im Gesundheitswesen- Institute for Quality and Efficiency in Health Care): Methods for assessment of the relation of benefits to costs in the German statutory health care system. Version 1, 24th January, 2008
11. Mauskopf J. Prevalence-based economic evaluation. *Value Health* 1, 251-259 (1998).
12. Sullivan SD, Mauskopf JA, Augustovski F, Caro J, Lee KM, Minchin M, Orlewska E, Penna P, Rodriguez Barrios JM, Shau WY. Budget impact analysis-principles of good practice: report of the ISPOR 2012 Budget Impact Analysis Good Practice II Task Force. *Value Health*. 2014 Jan-Feb;17(1):5-14. doi: 10.1016/j.jval.2013.08.2291. Epub 2013 Dec 13.
13. Marshall DA, Douglas PR, Drummond MF, et al.: Guidelines for conducting pharmaceutical budget impact analyses for submission to public drug plans in Canada. *Pharmacoeconomics* 26, 477–495 (2008)
14. Orlewska E, Mierzejewski P: Proposal of Polish guidelines for conducting financial analysis and their comparison to existing guidance on budget impact in other countries. *Value Health* 7, 1–10 (2004)
15. National Department of Health: Guidelines for Pharmacoeconomic Submissions. Pretoria, December 2012 (in: Government Gazette 36118, Feb 2013)
16. Guindo LA, Wagner M, Baltussen R, Rindress D, van Til J, Kind P, et al: From efficacy to equity: Literature review of decision criteria for resource allocation and healthcare decisionmaking. *Cost Eff Res Alloc* 2012;10:9.
17. van Velden ME, Severens JL, Novak A: Economic evaluations of healthcare programmes and decision making: the influence of economic evaluations on different healthcare decision-making levels. *Pharmacoeconomics* 2005, 23:1075–1082.
18. Rosen S, Long L, Fox M, Sanne I: Cost and cost-effectiveness of switching from stavudine to tenofovir in first-line antiretroviral regimens in South Africa. *J Acquir Immune Defic Syndr* 2008;48(3):334-44.
19. Walensky RP, Wood R, Ciaranello AL, Paltiel AD, Lorenzana SB, Anglaret X, et al for the CEPAC-International Investigators: Scaling Up the 2010 World Health Organization HIV Treatment Guidelines in Resource-Limited Settings: A Model-Based Analysis. *PLoS Med* 2010;7(12): e1000382. doi:10.1371/journal.pmed.1000382

### **3 Research question**

This thesis sets out to investigate how the results of cost and outcome analyses in routine care can be used to parameterise a budget impact model in a way that informs budgets and guideline changes and other policy decisions regarding HIV policy and programming. The thesis firstly reviews available global evidence from and methods used for modelled estimates of the cost of providing antiretroviral treatment (ART) as well as estimates of the budget impact of HIV interventions more generally. It then summarises the findings of cost and outcome analyses of adult and paediatric ART provision at the outpatient and inpatient level collected at seven different hospitals in various regions of South Africa. In a next step, the thesis describes how these findings were used to parameterise a health-state transition model predicting the size of the treatment cohort and budget required for the South African national public-sector treatment programme between 2009/10 and 2016/17, and discusses how this model has been used to inform the national ART budget, changes to clinical guidelines, and other policy decisions in South Africa over the last seven financial years. Lastly, the thesis examines the cost benefit of ART provision by the employer at the workplace level as an alternative to public-sector provision.

## **4 Literature review: Past use of economic evaluation and budget-impact models of HIV-related interventions worldwide**

This chapter summarises the findings of a review of the literature on economic analyses, including budget impact analyses, of HIV interventions worldwide, covering the last 27 years. The literature was reviewed in two parts: The first search focused on budget impact analyses of any HIV intervention, including HIV prevention and testing interventions as well as antiretroviral treatment, with the aim of describing the methods used in these analyses, with particular reference to the best practice principles established in the ISPOR guidelines reviewed in section 2.2 [1,2], in order to establish any methodological gaps left by these analyses. Because of the limited number of such analyses and the fact that even fewer of them used health-state transition models such as the model described in this thesis, a second search considered all economic analyses of antiretroviral treatment that had made use of a health-state transition model, with the aim of describing the methods used in the construction of these models.

Due to the purpose they fulfilled in the development of this thesis, the searches cover different time periods. The search for economic evaluations was done at the beginning of my work on the budget impact model discussed in this thesis, with the aim of establishing methodological gaps and informing the structure of this model; it covers the time period from 1988 to 2011. The time period for the budget impact analyses however was extended until 2014 due to the scarcity of such publications by 2011.

### **4.1 Background**

#### **4.1.1 Nomenclature**

Categorising the literature as either pertaining to a budget impact analysis or an economic evaluation (including cost, cost-effectiveness, cost-utility and cost-benefit analyses) was difficult, in part due to the fact that BIA as a separate method was introduced much later than economic evaluation, in 1998 [3], and was only formally defined fully in 2001 [4]. In addition, many papers that reported the results of a BIA were not labelled as such by the authors, while many papers on economic evaluations included limited information also relevant to a BIA, such as the full cost of the intervention, but without the intention of informing a budget (i.e., often without having identified a payer or giving consideration to this payer's budget period).

For the purposes of this review, based on the ISPOR guidelines summarised in section 2.2 [1,2], I therefore defined as budget impact analysis any paper that gave information on the future cost of an intervention from the perspective of a distinct payer or payers which had been declared by the analyst(s). Additionally, at least one of the results of such an analysis needed to be the full or incremental cost of introducing or scaling up an intervention, over a time period not exceeding five years; papers giving average costs per patient or per patient year only, or reporting costs over longer

time periods were not considered to be BIAs. Papers reporting resource needs estimates, often for a whole number of low- and middle-income countries together, were equally not classified as BIAs, since although they tended to report full costs, they did not explicitly mention the payer or payers. Lastly, papers retrospectively reporting expenditure rather than future costs were not considered BIAs either.

On the other hand, all papers that were declared by the authors to be cost, cost effectiveness, cost-utility or cost-benefit analyses were considered to be economic evaluations for the purposes of this review. As the focus of this thesis is on budget impact analyses, the review of economic evaluations was restricted to modelled evaluations of ART only, and these were reviewed mostly for information regarding the methods used in constructing health-state transition models, while the review of BIAs included analyses of any HIV intervention and both analyses that made use of a model and those that did not. If a paper reported on both a BIA and an economic evaluation using a health-state transition model, the two methods were considered separately in this review.

#### **4.1.2 Principles and eras of antiretroviral therapy**

Since many of the reviewed papers regarding ART compare drug regimens from different time periods of antiretroviral drug development with each other, the following section summarises the principles and recommendations governing the different “eras” of antiretroviral treatment over the past 30 years, in particular delineating the differences between monotherapy, combination therapy and highly active ART (HAART).

From the wealth of potential targets within the replication cycle of a human immunodeficiency virus, only a few lend themselves to successful therapeutic interference. Of these targets, the enzymes reverse transcriptase and protease can be targeted by orally administrable drugs - by reverse transcriptase inhibitors (RTI) and protease inhibitors (PI), respectively. A combination of three antiretroviral drugs, including at least one PI or one non-nucleoside RTI, known as highly active antiretroviral therapy, or HAART, employs a highly effective strategy of targeting the viral enzymes from different angles while controlling resistance-inducing mutations to a far wider degree.

In high-income countries with a high coverage of antiretroviral drugs, the time since the advent of antiretroviral therapy can be divided into three eras:

**Era 1:** 1987 to 1991 **Monotherapy** with zidovudine (AZT or ZDV)

**Era 2:** 1991 to 1995 **Combination therapy** with 2 or 3 nucleoside reverse transcriptase inhibitors

**Era 3:** 1995 to date **Highly active antiretroviral therapy (HAART)**, using a combination of at least three drugs, including at least one protease inhibitor or one non-nucleotide reverse transcriptase inhibitor.

For antiretroviral programmes in low- and middle-income countries, the World Health Organization (WHO) initially recommended the following HAART regimens as first line therapy (2 NRTI + 1 NNRTI) [5]:

*Stavudine or zidovudine + lamivudine + nevirapine or efavirenz.*

In 2010, this recommendation was changed due to the accumulating evidence on the severe and irreversible long-term side effects of stavudine, to

*Tenofovir + lamivudine + nevirapine or efavirenz* [6].

While the development of severe side effects of a single drug might necessitate the replacement of a single drug, in case of treatment failure a replacement of the whole treatment regimen will become necessary. In this case, the recommended second line therapy (2 NRTI + 1 PI) for developing countries was initially:

*Tenofovir disoproxil or abacavir + didanosine + lopinavir (ritonavir-boosted) or saquinavir (ritonavir-boosted* [5]).

In 2010, this recommendation was changed to

*Zidovudine + lamivudine + lopinavir (ritonavir-boosted)* [6].

## **4.2 Search strategy**

### **4.2.1 Budget impact analyses**

For the review of budget impact analyses of HIV-related interventions, I searched PubMed using the terms “((hiv[Title]) OR antiretroviral[Title]) AND "budget impact"[Title/Abstract]” for the years 1988–2014 which retrieved 20 abstracts, of which 17 were selected as relevant based on the abstract. After reviewing the full paper, eleven papers were deemed to be full budget impact analyses using the criteria set out in section 4.1.1. An additional eleven papers from the reference lists of these 17 papers were included in the review, out of which six were deemed to be of relevance based on the abstract. Of these, two were deemed to be real BIAs based on review of the paper. An additional two papers were identified from the reference lists of these six papers, of which one was deemed to be of relevance based on review of the full paper.

Information from the 14 included papers was retrieved using the criteria and recommendations for budget impact analyses detailed in the 2007 and 2014 ISPOR budget impact analysis guidelines described in Section 2.2 [1,2].



### **4.2.2 Economic evaluations**

I searched eight databases (PubMed, HealthSTAR, POPLINE, EconLit, HEED, Web of Knowledge [Science and Social Sciences], Embase and CAB Health) for the years 1988–2011 using any combination of the terms cost\*, econ\*, and HIV or AIDS. The identified articles were supplemented by reviewing the reference lists of identified articles, additional review articles, and grey literature (conference presentations and proceedings, books, and manuals). All articles in any language that contained modelled cost data of any kind as well as ART as an intervention were included, except where ART was used for the prevention of mother-to-child transmission only. Editorials and letters, articles without quantitative data, and articles that did not include a modelled estimate, such as papers reporting cost data from a single site, were excluded. The latter have been reviewed repeatedly in the past [7-10]. Forty-five published articles, one conference abstract, and four reports on modelled economic analyses of ART provision worldwide were included. Thirty-eight analyses were for single countries, four were for wider regions, and eight were global.

The included articles were reviewed with regards to their economic evaluation method, the type of model used, their time horizon, the outcome metric and result, and whether the input cost (often in the form of average per patient cost per unit time) was constant or had been varied by determinants such as types of regimens used, health state, time on treatment, and mode of delivery, in either the main or the sensitivity analysis.

### **4.3 Past budget impact analyses of HIV interventions including ART**

Compared to economic evaluation, budget impact analysis is a younger method, and relatively few such analyses have been undertaken for HIV-related interventions specifically. The search retrieved 14 analyses covering the time between 2000<sup>2</sup> and 2014 and eight countries (in order of frequency, US, Spain, Italy, Chad, Vietnam, Uganda, Canada and France). More details on the papers included in this review can be found in the Appendix to chapter 4.

Two of the 14 papers covered prevention interventions [11,12] (including a comprehensive range of prevention interventions in Chad [11], and methadone replacement therapy in Vietnam [12]), three covered HIV counselling and testing (HCT) [13-15], and the remaining ten covered ART, with the earliest paper comparing highly active ART with monotherapy [16], four papers analysing the impact of increasing ART eligibility [17-20], two considering simplifications to treatment regimens in the shape of fixed-drug combinations or “less-drug regimens” [21,22], and two analysing the impact of the fairly novel proteinase inhibitor (PI) darunavir (boosted with ritonavir, DRV/r) [23,24] which was approved by the US Food and Drug Administration (FDA) in 2006. One analysis in particular included not only the

---

<sup>2</sup> The earliest included paper, from 2000, was first-authored by Josephine Mauskopf, the author of the 2001 seminal paper defining BIA and one of the authors of the 2007 and 2014 ISPOR BIA guidelines [16]. Even though in the 2000 paper the analysis is not defined as a BIA, one of the keywords is “Budget impact” and the abstract talks about “total ADAP budget impacts” [16].

impact of increasing eligibility (from a threshold of 350 to 500 CD4 cell counts/microl, in Italy) but also of a range of cost-saving measures that could offset the necessary increase in the required budget, in particular of increasing the use of NNRTI-based regimens in new starters, single tablet regimens and PI/r-based monotherapy, and replacing branded drugs by their generic equivalent [20]. For more details see Table 1 in the Appendix.

While four of the analyses combined a BIA with a cost-effectiveness analysis [11,12,15,18], another paper reported on both budget impact and cost per patient [20]. Perhaps of note is that four of the 14 papers had at least one co-author who was in the employ of a pharmaceutical company [16,21,23,24]; in all cases, these were the companies producing the drug under analysis.

### **4.3.1 Methods used in budget impact analyses of HIV interventions**

#### **4.3.1.1 Perspective**

The choice of a perspective is of importance in a BIA since much of the remainder of the analysis follows from it. All but one paper [23] gave details regarding the perspective adopted (see Table 2 in the Appendix). In all but the US papers, this was the public health system (even though two papers from Spain gave the perspective as “perspective of pharmaceutical expenditure” [19] and “hospital” [21], respectively). In the US papers, owing to the complexity of funding for HIV-related healthcare in that country, the perspective was defined as that of the relevant payer or payers for the intervention under study, with two papers focusing on the Veterans Health Administration system [14,15], one analysis focusing on one state’s AIDS Drug Assistance Program (ADAP) programme [16], and two more papers specifically analysing the distribution of costs between all relevant funders (ADAP as well as federal Medicaid and Medicare) [13,17].

#### **4.3.1.1.2 Target population**

The ISPOR guidelines [25,26] specifically recommend for the perspective chosen to define a) the target population, b) the current and expected new treatment mix, and c) the resource use and cost that should be included in the analysis. While all of these aspects are important for the relevance and stability of the final outcomes, in the reviewed papers, the second two aspects tended to receive more attention than the definition of a target population. Of note is also that the target population for prevention and testing interventions is, by definition, different to that of a treatment intervention; while treatment is reserved for HIV-positive people at differing levels of immunological and clinical eligibility, testing is targeted at the general population, regardless of HIV status, and most prevention interventions are specifically designed for HIV-negative people, such as pre-exposure prophylaxis or medical male circumcision. As a result, defining a target population for prevention and testing interventions only requires data on the size of the general population, while deciding on a target population for treatment interventions requires data on, at the least, HIV prevalence and incidence over the analysis period, and current coverage with ART. Additionally, for analyses of the impact of a change in eligibility, a further break-down of the cohort of people requiring ART into categories defining eligibility (such as CD4 cell count strata) is needed; for analyses of the impact of a change in

drug formulations or a switch between single drugs, information on the distribution of the current and projected future treatment cohort into treatment regimens is required, including, for the budget impact of second-line drugs such as protease inhibitors, assumptions on the prevalence of treatment failure and drug resistance mutations.

In all reviewed papers but two [16,18], the target population appeared to be relevant to the chosen perspective. The exceptions are one analysis which used identically sized target populations for both monotherapy and highly active ART (HAART), seemingly assuming that HAART would not confer a survival benefit over the three years of the analysis [16]. The analysis of ART at different eligibility levels in Uganda assumed a closed cohort of people requiring ART at one of two eligibility levels, seemingly excluding any cases becoming newly eligible over the projection period [18].

In the reviewed papers on prevention interventions, the target population was based on an external epidemiological model (EpiModel [11] and Mode of Transmission Model [12]). In the case of the papers evaluating testing, the target population was a function of current testing coverage and different assumptions regarding increasing uptake as a result of the intervention [12-14]. One of these papers in particular gave detailed justifications for the population groups included and excluded in the analysis, based on the populations targeted by the payers under analysis [14]. BIAs of treatment options fell into two groups: Those analyses that used a detailed, pre-established model of HIV disease and treatment impact that had been used in economic evaluations of ART before [13,16,17], and those analyses that were based on the authors' own extrapolations of the number of people either currently receiving ART in a single cohort or group of hospitals, region or country, or registered as being HIV-positive, with additional assumptions about inflation for non-registered cases and incidence going forward [19-23].

#### **4.3.1.1.2 Treatment mix**

Of similar importance to the result of a BIA are assumptions about the current and future mix of interventions and intervention coverage, both at baseline and as a result of the programme(s) under study being rolled out. The paper analysing a host of prevention interventions in Chad did not give enough information about coverage levels to be able to analyse this [11]. Of the remaining 13 papers, ten included comprehensive changes in coverage resulting from the scale-up of the intervention or interventions under study [12-17,20-22,24], while three papers considered some, but not all likely changes in coverage resulting from the intervention [18,19,23]: The study of different ART eligibility options in Uganda included the impact on TB, but no other opportunistic infections [18], one analysis of different eligibility options in Spain applied the same distribution of the treatment cohort into treatment regimens as at baseline [19], and one analysis of DRV/r use in Spain limited the analysis to those options included in a single trial [23]. Only one paper of ART explicitly included a change in regimen distributions in both the baseline and the intervention scenario [24].

#### **4.3.1.1.3 Resource use and cost**

Only half of the papers included all resource use and cost implications of the scale-up of the intervention in question, as far as could be ascertained based on the information given. The largest omission across both those papers focused on ART and those reporting on prevention and testing interventions was the failure to include all HIV-related healthcare costs, not just the cost of the immediate intervention under study. Standard guidance [25] suggests that in an incremental cost analysis, those cost items for which resource use and prices are likely to be the same both at baseline and in the intervention scenario can be excluded from the analysis, but for this it either needs to be shown that they are the same, or the assumption has to be justified otherwise. This was not the case in any of the papers that omitted these cost items; it is furthermore questionable if the same guidance should apply to BIAs unless it is clear that the budget in question is limited to, for example, ARV drugs.

The more comprehensive papers included both inpatient and outpatient resource use and costs, with outpatient costs including ARV and non-ARV drug costs, the cost of laboratory tests and other diagnostics, visit costs, and overheads, and, for HCT in particular, the cost of the entire testing algorithm, including confirmatory tests in the case of rapid tests being the first test, the cost of pre- and post-test counselling where applicable, and if it was not done at the same visit, the cost of staff following up patients for post-test counselling.

#### **4.3.1.2 Analytical framework**

In terms of analytical framework, four of the 14 papers used a simple spreadsheet-based calculator only [11,19,21,23]; three of these papers were analyses of ART eligibility [19] or drug options [21,23], and all of them concerned European countries (see Table 3 in the Appendix). For the analyses of drug options, the choice of a simpler analytical framework (and the restriction to incremental cost items only, see above) could have been warranted if the perspective had indeed been limited to the payer of a drug budget only, but it is hard to know if this was the case given the limited information regarding perspective in the same papers (the perspective taken is given as "perspective of pharmaceutical expenditure" [19] and "hospital" [21] in the first two papers, and is not mentioned at all in the third analysis [23]). Of the remaining 10 analyses, five employ a health-state transition model [13,17,18,20,24] and the other five some other type of model, the classification of which varies widely - one is termed a "decision-tree model" [12], one a "dynamic model" [14], one a "decision tree" [15], one a "static deterministic model" [16], and one a "simple budget impact model" [22].

For all but the calculator-based analyses and the one termed a "simple budget impact model", I reviewed the appropriateness of assumptions regarding changes in population, disease severity and treatment patterns, as well as the comprehensiveness of included health outcomes and costs, as stipulated by the ISPOR guidelines [1,2] - though there is some overlap between the latter aspect and the aspects covered under 4.3.1.1.

#### **4.3.1.2.1 Assumptions regarding changes in population, disease severity and treatment patterns**

Assumptions in all except three of the nine model-based analyses seemed warranted, based on the available information. In the remaining three papers, analysts chose unusual limitations to their analysis, and did so without appropriate justification: In the paper on methadone-replacement therapy (MRT) in Vietnam, the model was only run for one year, with the size and distribution of the population assumed constant thereafter and only MRT coverage being scaled up [12]; in the early paper of the impact of HAART vs. monotherapy, the different regimens seem to impact OI incidence only, but not mortality [16], and in the budget impact analysis of DRV/r for highly treatment-experienced patients in France [24], the unusual decision was taken to compare DRV/r to a baseline in which most patients with PI resistance would be given ritonavir-boosted tipranavir (TPV/r) instead which was not available in France at the time, effectively turning this BIA of DRV/r into a head-to-head comparison of DRV/r and TPV/r for highly treatment-experienced patients, and possibly underestimating the cost savings from DRV/r.

#### **4.3.1.2.2 Health outcomes included**

Even though a budget impact analysis does not traditionally take health outcomes into account, outcomes such as survival in care are still relevant for the calculation of the overall size of the treatment cohorts and the cost of treating them, especially where survival or retention in care, or both, is likely to differ between treatment arms. For this reason, I reviewed the methods used in calculating health outcomes in the included models alongside their other characteristics.

Five of the nine model-based analyses included all HIV-related health outcomes for the affected population [12,13,17,20,24]. None of the analyses included non-HIV related outcomes. Of the four analyses with limited outcomes data, two of the HCT analyses included either the results of the test only, or the results of the test and of ensuing ART only, but no other outcomes such as morbidity and mortality [14,15]. As mentioned before, the analysis of HAART vs. monotherapy in the US included an impact on OI incidence only, but not on mortality [16], and the analysis of changing ART eligibility in Uganda included TB, but no other OIs [18]. Those BIAs that were based on trial data only [24] might have overestimated the intervention's effectiveness in a routine setting. Across analyses, and by design, the short-term time frame necessary in a BIA will have led to an underestimation of both the health and cost impact of longer-term side effects.

#### **4.3.1.2.3 Costs included**

Somewhat related to the decisions regarding inclusion and exclusion of health outcomes above, six of the nine analyses included comprehensive resource use and costs [13,16,17,18,20,24]. As stated under 4.3.1.1, the shortfalls in accounting for cost items were mostly with regards to cost items beyond those necessary for the intervention under study - such as the inclusion of ART in HCT studies, or inpatient care in ART studies. Across the board, the most comprehensive analyses were those of ART eligibility changes, which included both inpatient and outpatient care, and all outpatient costs, not just the cost of ARVs [17,20,24].

#### **4.3.1.3 Impact on access and uptake**

A third major concern expressed in the ISPOR guidelines is that BIAs include a realistic approximation of accessibility and uptake of the new intervention over the examined time period, as well as an acknowledgement of its replacement effect on existing interventions and services [1,2]. The first two items were not always easy to delineate if only a combined assumption concerning coverage, or of coverage scale-up, was given; where this was the case, a single coverage point estimate was interpreted as “access”, and a change in coverage over time was read as “uptake”. Using this approach, only three papers did not take access or uptake into account at all - one simply tagged coverage (of ART at higher eligibility) to the baseline level, 53%, throughout the analysis [18], and two did not supply any information regarding this [11,23] (see Table 4 in the Appendix).

In terms of access restrictions, essentially a supply-side concern, only five of the 14 analyses included in this review explicitly took these into account, mostly through assuming a certain limit to how far coverage could be scaled up [12,13,19,22,24]. All of these access limitations appeared reasonable and grounded in the realities at the programme level. For example, the analysis of MRT scale-up in Vietnam assumed a 70% coverage cap [12]; the analysis of the impact of expanding HCT on the budgets of “US government discretionary, entitlement, and separate testing programs” purposely excluded privately insured patients and those covered by US Veteran Affairs programmes [13]; the analysis of new ART eligibility guidelines in Spain capped the uptake of the new guidelines at 80% [19]; the analysis of “less-drug” ART regimens in Italy restricted access to these regimens in some of the analysed scenarios [22]; and the analysis of the scale-up of DVR/r in France targeted highly experienced patients with PI mutations only [24].

In terms of limitations in uptake, a demand-side concern, one analysis did not give any information on whether and how this was taken into account [11]. Those papers that ignored uptake did so mostly because they only modelled the budget for a single year [12,19]. Out of the remaining 13 papers, a full nine took uptake, or a change in uptake, into account [13-17,20-22,24], mostly by varying uptake to some degree either over time, as a function of the scenario of analysis, for example by varying ART uptake from 66% for monotherapy to 100% for HAART [16], or as a function of another model parameter, for example by varying ART uptake from 20% to 85% depending on CD4 cell count stratum [20].

With regards to their treatment of a replacement effect, in other words, whether the use and effects of both the new intervention as well as any current interventions that might be replaced by the new intervention had been included, only seven of the 13 analyses seemed to take this into account comprehensively [13,14,16,17,18,20,24]. Since all of these analyses also made use of a health-state transition model, it could be argued that the distribution of a cohort into different service modalities that is necessary for the consideration of replacement effects is difficult to achieve in a simple calculator spreadsheet. One of the papers, the paper comparing a number of prevention interventions in Chad, reported on a full (rather than incremental) analysis in which the comparator was “do

nothing”, which means that the exclusion of replacement effects was likely warranted [11]<sup>3</sup>. The remainder of the analyses did not consider replacement effects comprehensively because, just as seen in the review of the health outcomes and resource use in Section 4.3.1.2, they did not include the full spectrum of interventions that would be impacted by the scale-up or change to the service they analysed, which would have meant including ART in HCT analyses, or inpatient care in ART analyses. Other analyses artificially restricted the replacement effect by limiting the entry population [18], assuming the same distribution into ART regimens as at baseline [19], or having an artificial baseline containing a drug that was not currently available in the setting under study [24].

#### **4.3.1.4 Uncertainty analysis and validation**

All but two of the Spanish analyses [19,23] included some form of uncertainty analysis (Table 5 in the Appendix). In all cases, this included a sensitivity analysis, most often a univariate one; all of these sensitivity analyses interrogated parameter uncertainty in input parameters, but only three papers also included structural uncertainty in the choice of the analytical framework in their analyses [13,15,20]. This was done by including a 10- instead of 5-year modelling framework [13], by broadening the perspective and including an impact on productivity in the analysis [18], or by assuming no restrictions in uptake [20]. Two papers reported on additional scenario analysis, one by testing what would happen if enrolment under new ART guidelines was capped in not just one, but both US states under study [17], and one by testing four different scenarios defined by different levels of ART eligibility and coverage [22]. While the former included some variation in the cost of ART in the scenario analysis [22], none of the two papers included variation in the inputs for health outcomes or alternative structural assumptions as stipulated in the ISPOR guidelines [1,2].

Finally, the 2014 ISPOR guidelines recommend validating the computing framework and input data, including, at the least, a check for face validity of central inputs with decision makers and the verification of all calculations [2]. With the exception of one paper that mentioned having used expert opinion in arriving at the model endpoints that would be most useful for programming [14], none of the reviewed papers reported on any such validation having been undertaken.

#### **4.3.2 Results of budget impact analyses of HIV interventions**

As a result of not only the wide variety in the interventions examined but also in the methods employed, as described above, the results of the reviewed budget impact analyses vary widely. These results are summarised separately for each type of intervention below.

---

<sup>3</sup> It needs to be noted however that this is an artificial comparator since most of the interventions included in the final recommended package were already part of government policy in Chad at baseline [1].

#### **4.3.2.1 HIV prevention interventions**

The two papers reporting on the budget impact of HIV prevention interventions both found that over the examined time period, interventions had a positive budget impact - in other words, they were net costing rather than cost saving [11,12]. In the case of the analysis of a range of prevention interventions in Chad, this was likely because the cost of ART provision was not included since at the time of the study, 2003, this was not an option available in the public sector [11]. Based on the separate CEA, the authors found a large group of the examined interventions to be cost-effective against a threshold of USD 1,000 per HIV infection averted, and that those interventions found to be cost effective “do not require large budgets” [11]. Annual budgets for those interventions that were either strongly recommended or recommended based on their cost effectiveness ranged from USD 50,000 (strengthening screening of donated blood) to USD 1 million (HIV education of high risk groups), and the total budget of these recommended interventions was found to be USD 3.2 million [11]. (Of note is that most of these interventions were already part of the current HIV strategy in Chad at baseline, making the authors’ choice of a baseline of “do nothing” questionable, as mentioned in 4.3.1.3.) In the case of the analysis of MRT in Vietnam, the authors calculated a budget impact of USD 97 million over 5 years [12]. Again, in the accompanying CEA they found this intervention to be cost effective at a threshold of 3 x gross domestic product (GDP) per capita [12].

#### **4.3.2.2 HIV counselling and testing interventions**

The three papers reporting on the budget impact of HIV counselling and testing interventions all focused on expanding coverage with HCT in the US, with one paper examining increasing testing frequency from, on average, every 5 instead of every 10 years [13], the second examining expanding coverage with routinely offered HCT from 2% to 15% per year [14], and the third analysing adding an electronic reminder system to the latter intervention [15]. As with prevention, all of the analyses found a positive budget impact, but of varying sizes. While the first paper found a budget impact of USD 2.7 million over 5 years for 46,000 additionally identified cases of HIV, with testing only contributing 18% of this amount and the largest budget increase stemming from ART [13], the second found that their more limited testing intervention had a comparatively smaller budget impact of USD 290,000 over 2 years, while only identifying 21 new cases [14], and the third found a budget impact of USD 81,726 over 1 year for the cheapest scenario, a reminder system without pre-test counselling [15].

#### **4.3.2.2 Treatment interventions**

##### **4.3.2.2.1 Changes to ART eligibility**

Four analyses focused on the impact of increasing eligibility thresholds and criteria for antiretroviral treatment in a number of countries and settings [17-20]. Two of these papers looked at expanding the eligibility threshold from 200 to 350 CD4 cells/microl [17,18], a move supported by the 2010 WHO ART guidelines [26]. The first paper was specifically set up to test whether the expansion of eligibility did not exceed allocated Medicaid budgets in the US states of Georgia and Massachusetts in order to meet the criteria of a Medicaid Section 1115 demonstration application. The authors found that neither demonstration project would meet the 5-year test of “no increase in federal spending over and



above what would be expected in absence of demonstration project", contrary to what both states' applications had stipulated [17]. The second paper analysed the budget impact of the eligibility increase for Uganda and found that covering 53% of those that became eligible in a fixed cohort of 520,000 HIV-positive people under the 350 eligibility criterion would cost an additional USD 261,651,942 over 5 years, and USD 872,685,561 over 30 years. Again, in the accompanying CEA they found this move highly cost-effective, as the cost per life-year saved was below GDP per capita [18].

Two more papers compared the cost of expanding treatment eligibility even further, from a threshold of 350 to 500 CD4 cells/microl [19,20], as stipulated by the 2013 WHO ART guidelines [27]. The first analysed the impact of the Spanish ART guidelines from 2011 which included eligibility at <500 CD4 cells/microl as well as additional clinical and age criteria. The authors found that applying these guidelines in a group of hospitals contributing to the VACH<sup>4</sup> HIV cohort would increase the cost of ARV drugs by €3,270,975, or 3%, over the first year [19]. The second analysis looked at the impact of similar guidelines issued in Italy in 2011 on the cost of treating the HIV-infected population of the Lazio region between 2012 and 2016 and found that earlier initiation would increase the budget by 2.3% [20]. In contrast to the other papers, this paper specifically also looked at the impact of a number of cost-saving measures, such as increasing the use of NNRTI-based regimens in new starters (from 27% to 50% coverage), introducing single tablet regimens and PI/r-based monotherapy, and replacing branded drugs by their generic equivalent [20]. The authors found that these measures would decrease the budget impact by 0.3%, 1.5%, and 3.3%, respectively, more than making up for the budget increase from the introduction of the new guidelines [20].

#### **4.3.2.2.2 Changes to ART regimens and drug formulations**

Five of the papers reported on the budget impact of changes in ART regimens, including changing from NRTI-based monotherapy to HAART [16], replacing other protease inhibitors by DRV/r [23,24] or by PI-based mono- and dual therapy [22], and of changes to drug formulations, in particular by substituting a number of first-line drug regimens with a fixed-dose combination of EFV, emtricitabine (FTC) and TDF taken as a single drug [21].

The first paper, reporting on the impact on the New York State AIDS Drug Assistance Program of replacing monotherapy by HAART [16], is much older than the others - HAART became the recommended standard therapy around 1995, see section 1.4 - and, as mentioned above, is one of the oldest BIAs ever published. The authors found that introducing HAART would increase the state's ADAP budget by 115%, though the entire budget increase would be recouped by savings on OI treatment costs as a result of the higher effectiveness of HAART especially with regards to maintaining patient's immunocompetence and high CD4 cell count levels, resulting in a net decrease in the required ADAP budget of 0.4% [16].

---

<sup>4</sup> "VACH" being short for "VIH y AdvanCedHIV"

One of the two papers examining the impact on ARV drug expenditure of DRV/r in Spain looked at the cost of switching those 15% of Spanish ART patients who at baseline were on a regimen of 2 NRTI + PI or NNRTI to either a regimen of 2 NRTI + DRV/r or alternatively to DRV/r monotherapy [23]. The authors found that this would save €62 million over 3 years [23]. The second paper examined the evolution of the ARV and non-ARV budget over 3 years as a result of scaling up DRV/r coverage of highly treatment-experienced patients from 20% to 70% in France [24]. This paper found a net saving of €11.4 m (2.9% of total budget) under the DVR/r scale-up, mostly again from preventing patients' CD4 cell count levels falling, with the associated higher hospitalisation costs [24].<sup>5</sup> The third paper examined the budget impact of PI-based dual and monotherapies over the current mix of ARV regimens over 3 years in Italy and found that, depending on the chosen scenario, ART expenditure would decrease by between 6.7% and 12.8% in the examined hospitals, or by 1.1% to 1.2% for the entire Italian National Health Service [22].

The last paper examined the impact of substituting a number of first-line drug regimens with a fixed-dose combination of EFV, FTC and TDF in Spain over 1 year and found that the incremental budget would increase by between -1.99 and +6.73%, based on the replacement scenario chosen [21].

#### **4.3.3 Conclusions: Lessons learned from the review of past budget impact analyses of HIV interventions**

A number of conclusions can be drawn from the review of past budget impact analyses of HIV interventions.

- 1. A budget impact analysis is of limited use without a clearly identified payer and a circumscribed budget.** As seen with a number of the BIAs for European countries, in contrast to the US system where HIV-related healthcare costs are borne by specific payers, some of which (such as ADAP) are specifically designed to bear costs from HIV only, budget analyses for a country's public sector more generally sometimes struggle with identifying a designated payer and a clearly delineated budget that they can inform.
- 2. The budget impact of most interventions will be positive, unless specific measures are included that decrease costs.** In comparison to the BIAs of prevention interventions, a number of the reviewed ART-related budget impact analyses started from a different premise, by specifically examining ways to make an existing rather expensive intervention cheaper to implement and roll-out further. Accordingly, many of them managed to identify negative budget impacts, or cost savings.

---

<sup>5</sup> As mentioned in section 4.3.1, the results of this study are likely an underestimate, as the baseline contains a novel PI, TPV/r, which was not available in the public sector in France at the time, making the baseline artificially expensive [24].

3. **The target population for BIAs of antiretroviral treatment that have a period of analysis of more than 1 year needs to be informed by the current cohort of identified HIV-positive people in a country or region *plus* additionally eligible and identified cases.** In most cases this will mean that incidence has to be taken into account as well as the distribution of people into eligibility-defining health states and, in the case of BIAs of different drug regimen choices, into regimens have to be taken into account. This seems to be easiest done in comprehensive health-state transition models.
4. **BIAs of both prevention/ testing interventions and ART from a public-sector perspective need to take into account more than just the resource use and cost of the intervention under analysis in order to capture the full impact on the budget.** For BIAs of prevention/ testing interventions this means including the down-stream costs of ART in those people for whom prevention fails and who test HIV-positive. For BIAs of ART-related interventions this means including both outpatient and inpatient costs, and at the outpatient level more than just ARV drug costs. The only exception to this is if the perspective has been clearly and justifiably chosen to be that of the ARV drug budget alone, and there is demonstrated reason to believe that all other costs will stay the same.
5. **If more than ARV drug costs or HIV test costs are included, costs should be modelled in a way that links resource use to disease progression,** by using a metric such as CD4 cell counts.
6. **Almost none of the reviewed papers provided any information on a validation of their analytical framework and input data.** Such information regarding validation is standard in the reporting on epidemiological models and should be included in economic models and analyses as well.

#### ***4.4 Past modelled economic evaluations of antiretroviral treatment***

##### **4.4.1 Types of analyses identified**

Starting in 1992, a wealth of papers have been published on the economics of antiretroviral treatment. The first papers were prompted by the need to make the economic case for public-sector provision and funding of ART in high-income countries, pointing to the beneficial effect of ART not only on survival and quality of life but also on shifting resources from expensive inpatient care to cheaper outpatient care and from the treatment to the prevention of opportunistic infections. From about 2001 on, the same methods were used to also make the case for extending ART provision to low- and middle income countries (LMIC) characterised by both higher HIV prevalence and lower ability to pay for the programmes themselves.

Publications included two modelled cost analyses for two high-income countries and 23 modelled cost-effectiveness or -utility analyses for nine high-income countries (HIC) as well as 13 cost-effectiveness or -utility analyses for six low- and middle income countries. Furthermore, the search identified four analyses of regional cost and cost-effectiveness of ART and eight studies of the global cost and cost benefit of ART, either for all countries world-wide or for a large number of LMIC. The details of these papers are summarised in the Appendix for chapter 4.

Thirty-eight analyses modelled ART programmes within a single country [28-65] (Table 6 in the Appendix). Most of the 25 analyses from high-income countries (HIC) compared the incremental cost and effectiveness of a new drug regimen with that of an older one [36,38-40,47,50-53]; only one analysis considered the impact of a change in eligibility criteria [63]. Amongst the fourteen low- and middle-income-country analyses, twelve analyses focused on the choice of eligibility criteria [28,29,54-59,61,62,64,65]. Two of these were analyses of the cost and cost benefit of universal testing and treatment [28,29]. One analysis compared ART with no ART [57], one, first-line treatment with first- and second-line treatment [54], and one, different regimens for women previously exposed to single-dose nevirapine as part of prevention of mother-to-child transmission [61].

The four regional studies [66-69] all focused on sub-Saharan Africa (with one study [69] additionally including Southeast Asia) (Table 7 in the Appendix). These studies modelled the cost of defined increases in ART coverage from a low baseline [66,67] and the cost effectiveness of ART provision through the specific setting of an antenatal care clinic [68].

The eight global studies, published between 1997 and 2011, describe a clear evolution in both data availability and modelling techniques [70-77] (Table 7 in the Appendix). The older analyses estimate cost based based on assumptions only [70,71], while later analyses model global cost under concrete programmes, based on per patient cost estimates from relevant LMICs and more advanced epidemiological models of the number of patients in need of ART [73-77].

#### **4.4.2 Methods used in past modelled economic evaluations of ART**

##### **4.4.2.1 Types of analyses**

The search identified 38 modelled economic analyses of single-country ART programmes [28-65]. Most of the 25 HIC analyses compared the incremental cost and effectiveness of a drug regimen of one phase of antiretroviral drug development to that of one of the former, with the biggest output of such analyses being prompted by the introduction of new classes of antiretroviral drugs such as protease inhibitors [36,38-40,47,50,52] and a fusion inhibitor [51-53]. Apart from six studies adopting a societal perspective [34,42,45,46,63,65] (only one of which specifically including indirect costs [34]), all analyses analysed cost from a provider perspective, with some specifically identifying the payers and comparing different cost reimbursement strategies [41,48], or the impact of earlier treatment initiation [28-30,41,44,45].

Four analyses modelled the cost of ART provision in a specific region [66-69], all of which focused on sub-Saharan Africa (with one study additionally including South East Asia [69]). Studies modelled the cost of defined increases in ART coverage from a low baseline [66,67] and the cost effectiveness of ART provision through the specific setting of an antenatal care clinic [68]. Details with regards to model characteristics or sources of input data were unavailable for two analyses [66,67]; one publication was a systematic review of cost-effectiveness analyses of HIV interventions, with the cost of ART modelled on the cheapest available prices at the time [68]; the other used an epidemiological model [69]. All analyses were conducted from the provider perspective. Time horizons, where available, were five years [66], eight years [67], and lifetime [69]. One paper used the same constant input cost for all patients [67]; two papers varied input cost by regimen [66,69].

Eight papers estimated the cost of global antiretroviral treatment provision [70-77]. Published between 1997 and 2011, they show a clear evolution in both data availability and modelling techniques. Almost all papers analyse the global cost of ART provision only, with the exception of one paper modelling the incremental cost effectiveness of UNAIDS' new "investment approach" to achieving universal ART access [77] and one paper analysing the cost benefit of maintaining the 2011 cohort of patients supported by the Global Fund to Fight AIDS, Tuberculosis and Malaria [76]. While the older analyses estimate cost only based on the number of HIV positive people from a number of sources, varying assumptions of start coverage, and cost modelled on both guidelines and prices from high-income countries [70-72], later analyses model global cost under concrete programmes, such as WHO's "3 by 5" programme [74] and the GFATM [73,75], based on per-patient cost estimates from relevant low- and middle income countries and more advanced epidemiological models of the number of patients in need of ART, such as the Spectrum model [75,76] and the Resource Needs Model [77]. Accordingly, all analyses are conducted from the provider perspective, with the exception of the cost-benefit analysis which adopted a societal perspective [76]. Time horizons vary between one and ten years.

Three of the eight analyses used constant input costs for all patients [70-72]; two varied input cost by regimen [74,75], and one additionally by health state [75]. One study included the impact of access to pool procurement prices negotiated by the Clinton HIV/AIDS Initiative on per patient cost [74], one varied drug prices by per capita Gross National Product [73] and one assumed a reduction of per patient cost by 65% by 2020 as a result of task-shifting and cheaper point-of-care diagnostics [77].

#### **4.4.2.2 Interventions considered**

Amongst the thirteen LMIC analyses, nine analyses focused on the choice of eligibility criteria [28,29,54-56,59,62,64,65], with three analyses prompted by the revised World Health Organization (WHO) treatment guidelines issued in late 2009 [59,60,29] and one examining the impact of universal testing and treatment, i.e., regardless of CD4 cell count-linked eligibility [28]. One analysis compared ART with no ART [57], one first-line treatment with first- and second line treatment [58], and one different regimens for women previously exposed to single-dose nevirapine as part of PMTCT [61].

#### **4.4.2.3 Source and treatment of cost data**

The source of cost data for all single-country analyses were real world settings - trial data for most HIC analyses, single-site clinic cohorts for most LMIC settings. Data for drug costs often came from national formularies, using average wholesale prices, or, for studies in LMIC, from drug price databases maintained by WHO (Global Price Reporting Mechanism), the Clinton Health Access Initiative (CHAI), or the Global Fund for AIDS, Tuberculosis and Malaria (GFATM). Inpatient costs and resource utilisation were distilled from databases or insurance reports or from data maintained by WHO's CHOICE team. Data on laboratory costs came from individual hospitals' payment offices or from previously published studies. Most papers varied input cost (ie, the cost per patient per unit of time) by protocol-related factors such as treatment regimen, health state (defined by the absence and presence of symptoms, opportunistic infections or AIDS-defining diseases and/ or CD4 cell count levels) and/ or by time on treatment (see Table 1). Only three papers, both of them on LMIC, varied cost by level of care (secondary vs. tertiary) [57] or mode of healthcare provision (public vs. private) [58,64].

Costs were discounted in almost all studies at rates between 3% and 6% per annum, with the majority of studies in LMIC using a 3% discount rate. Very few studies varied the discount rate in sensitivity analysis [33,40,43].

#### **4.4.2.4 Analytical framework**

A majority of the analyses employed health state transition models, mostly using Markov techniques, with seven studies using versions of the Cost-Effectiveness of Preventing AIDS Complications (CEPAC) model [44-47], a health state transition model evaluated by Monte Carlo simulation, or its international version [55,59,61]. The time horizon of these models, i.e., the period over which outcomes and/ or cost were projected forward, was set at between one and 20 years; or analyses, most often in Markov models, were run for the lifetime of the cohort without further specification. Seven of the 33 analyses were run over five or less years [30,35,36,38,40,41,43,56], eleven for five to 25 years [32,33,36,38,39,40,43,49,54,58,60], one each for 30 [29] and 43 [28] years, and 17 for the lifetime [31,34,37,44-48,53,55,57,59-61,64,65] or the half life of the cohort [50]. Three models projected for two different time horizons [36,38,53]; four analyses did not give information on their time horizons [42,49,51,52]. Models further varied according to their assumptions about the duration of a beneficial effect of the ART regimen under study and their output parameter - about half of all analyses used cost per life-year saved and the other half used cost per quality-adjusted life-year (QALY) gained.

#### **4.4.3 Conclusions: Lessons learned from the review of modelled economic evaluations of antiretroviral treatment**

A number of conclusions can be drawn from the review of modelled economic evaluations of antiretroviral treatment.

1. **As with budget impact analyses, the number of health states should be enough to include all those that represent a clear difference with regards to cost, survival in care, or both.** While most of the reviewed papers used some or other patient-level category to distinguish health states, including CD4 cell count at initiation and at present, viral loads, time on treatment, and drug regimens, very few took all those categories into account that would make a difference in terms of cost or survival or both, and almost none justified their choice of states. This includes differentiating cost and/ or transition probabilities between the first year on treatment and later years, and explicitly modelling the change in regimens over time - not only between first and second (or third line) but also single-drug changes within these lines, should these have an important impact on costs (including those to treat side effects) and/ or outcomes.
2. **Differences in results between analyses cannot be interpreted without information on break-down of both input costs and cost results by item (eg, staff, drugs, diagnostics, inpatient vs. outpatient costs).** The high variation in results between countries point to the fact that the relative cost effectiveness of a given regimen might rely more on intra-country factors such as the cost of inpatient care and the quality of HIV care than on the regimen used. The generalisability of cost results from the reviewed papers is therefore hampered by the fact that most studies included aggregated costs only, with no information on unit costs and quantities other than for drugs, or on the amount in which capital costs (eg, building, equipment) or administrative costs and salaries were included into inpatient and outpatient costs.
3. **Where possible, data regarding resource use and outcomes need to come from the same setting in order to uphold the claim that these resources led to these outcomes.** This was the case in very few of the reviewed models, though increasingly so in the later analyses and those from LMIC.
4. **The still prevalent contention that HAART saves economic resources might be a result of effectiveness studies conducted in the 'window of opportunity' phase in 1996 and 1997 when HAART had just been registered, whose results have been used widely in the analyses presented here.** The only other economic analyses that see actual cost savings are those that include an effect of ART on transmission - though often only after decades of very high population coverage under a universal test and treat scenario.

#### ***4.5 The scope of economic analyses of ART in South Africa***

At the start of my work on this thesis, a single economic analysis had been undertaken for South Africa, a cost-utility analysis of antiretroviral treatment in the ART clinics in Khayelitsha, a collaboration between Medicins Sans Frontieres and the provincial government of the Western Cape [57]. This study was also the first incremental cost-effectiveness study of antiretroviral treatment provision in any

low- or middle-income setting that was based on real-world data rather than modelling. Using cost and survival data from a cohort of patients treated in the local clinic and surrounding hospitals in 2002 and extrapolating these over a 10-year time horizon using Markov modelling techniques, the analysis arrived at an incremental cost-effectiveness ratio (ICER) of HAART of USD 1,806 per quality-adjusted life year, compared with a ICER of current therapy without ART of USD 2,040 per quality-adjusted life year.

Since then, as mentioned in section 1.4, the South African ART programme has been subjected to more cost analyses than any other ART programme outside the United States [78-88], though none of these analyses used modelling techniques, and none were designed to inform budgets (and have therefore not been included in the review above). Many more economic evaluations for low- and middle-income countries generally have used South Africa as a case in point, in part due to the superior availability of outcomes and cost data, including six of the studies reviewed in section 4.4 [28,29,59,60,62,65]. These included economic evaluations of various changes to ART eligibility [28,29,59,60,62] and monitoring strategies [65]. None of these studies however was a budget impact analysis; in fact, with the exception of the study by Cleary et al mentioned above, none of them seems to have been aimed at informing decisions by the South African government, but rather used South Africa as a case study for decisions facing any funders, most often international donors, supporting ART programmes in sub-Saharan Africa.

#### ***4.6 Choosing an analytical framework for the budget impact analysis***

Based on the recommendations of the ISPOR guidelines [1,2] discussed in section 2.2, as well as the research question and the above review of existing models used in economic evaluations and of budget impact analyses of HIV interventions, an analytical framework and specific model elements were chosen for the budget impact model of changing the ART guidelines in South Africa. This chapter introduces both.

##### **4.6.1 Incorporating current guidelines for budget impact analyses**

In this section, I summarise the recommendations for budget impact analyses reviewed in section 2.2 [1,2] and explain how they have been implemented in the budget impact model presented in this thesis.

The ISPOR committees' recommendations for good practice in budget impact analyses [1,2] urge the analyst to:

1. let the **perspective** of the specific healthcare decision maker define which data to use regarding the target population, current and expected new treatment mix, and relevant resource use and costs [1];
2. use the simplest possible **analytical framework** that produces transparent, valid estimates [1];



3. only use a condition-specific **cohort or patient simulation model** (instead of a simple spreadsheet-based cost-calculator) if there are anticipated changes in the target population, disease severity mix or treatment pattern [2];
4. if using a health-state transition model, make sure that **all health outcomes and costs** for the total population affected by the intervention are included [1];
5. include the impact of potential **access** restrictions, anticipated **uptake**, and the use and effects of the new interventions as well as current interventions that might be replaced by them [2];
6. restrict **uncertainty analysis** to parameter uncertainty in input values and structural uncertainty in the choice of the analytical framework [2]; if that's not possible due to the lack of data on the proposed new intervention, undertake a scenario analysis representing alternatives of relevance for the decision-maker [1] taking into account plausible alternative input parameter values and structural assumptions [2];
7. undertake **validation** including, at the least, a check for face validity with decision makers and verification of calculations [2].

In line with recommendation 1, the analysis presented in this thesis takes the perspective of public-sector payer. As a result, the model calculates inpatient and outpatient cost of ART separately, in order to inform both the ring-fenced Conditional Grant for HIV/AIDS, which pays for all ART provision at the outpatient level, and the HIV-related share of the general hospital budget which pays for whatever inpatient care might be utilised by patients on ART, though the model's main focus remains on the calculation of outpatient cost. Also due to this perspective, the modelling timeframe is defined by South African budget planning cycles. Based on a request by the National Department of Health, the model was set up to run for 8 years, covering two mid-term expenditure framework periods of 3 years each, with one additional year added at the beginning and the end, resulting in a projection period from financial year 2009/2010 to 2016/17.

In terms of the choice of analytical framework (recommendations 2, 3, and 4), the complexity of the development of HIV disease, especially under antiretroviral treatment, called for the use of a health-state transition model, rather than a simple cost calculation spreadsheet. Sections 4.6 and 9.2 give more details on the structure of this model and a justification for each of its elements.

In terms of considering the impact of restrictions in accessing the new intervention or programme and its anticipated uptake (recommendation 5), I discarded the first since the new treatment guidelines were aimed at increasing (not restricting) access as an effect of lowering treatment eligibility thresholds, and carefully extrapolated data regarding potential future uptake resulting from a similar eligibility change in the private sector (see Chapter 9 for more details).

In terms of sensitivity analysis (recommendation 6), due to a lack of relevant, context-specific data on the cost and outcomes of the specific guideline changes under discussion, I restricted our treatment

of uncertainty to a scenario analysis involving the treatment guidelines in practice at the time of analysis (baseline scenario) as well as two different sets of future guidelines that were being discussed by government.

In terms of model validation (recommendation 7), all model calculations have been scrutinised repeatedly by other analysts internal and external to this analysis, and the framework and results of the analysis have been discussed in detail with both local and international policy makers and programme experts.

#### **4.6.2 Elements required for a budget impact model of new ART guidelines in South Africa**

As mentioned, due to the complexity of the disease and the large number of replacement effects between types of care, especially when new drugs are introduced, for this budget impact model a health-state transition model was chosen as the analytical framework. In summary, the model incorporates the following elements:

- Scenarios of analysis (old guidelines vs. two sets of potential new guidelines), defining eligibility criteria and choice of drug regimens
- Health states defined by
  - age group (adults: current age; children: current age and age at ART initiation)
  - type of care (pre-ART, first-line ART, first-line treatment failure, and second-line ART)
  - type of drug regimens (up to 3 first- and second-line regimens, depending on scenario of analysis)
  - CD4 strata based on patients' current CD4 cell count or, for children, percentage.

Based on an analysis of cost, mortality and loss to follow-up in the large South African ART cohort that contributed data to the analysis of model parameters, I decided to define health states by a) age group, b) type of care, c) type of drug regimen (for cost only) and b) patients' current CD4 cell count or percentage.

In terms of age groups, I differentiated an adult population (>15 years of age) from a paediatric population, with the paediatric population further differentiated by current age as well as age at treatment initiation, in order to capture the different treatment regimens recommended in the South African ART guidelines. Each age group is then distributed into types of care which include pre-ART (differentiated by cost only), first-line ART, first-line treatment failure, and second-line ART. Within types of care, outpatient cost is further differentiated by regimen, with up to three different first-line and second-line regimens for adults and children each, depending on the scenario, while inpatient cost is differentiated between pre-ART and ART care as well as CD4 cell count category. CD4 cell count categories for the adult population are defined as >350, 200-350, 50-199, and <50 cells/microl. For children aged 6 to 13, CD4 strata are defined as >35, 15-35, 5-14, and <5%. CD4 strata for children under 6 are defined as CD4 >35, 20-35, 5-19, and <5%.

I chose to solve the model deterministically but introduced time heterogeneity by conditioning all transition probabilities between health states (including mortality, loss to follow-up, treatment failure, and coverage with second line treatment) on time since treatment initiation for the largest sub-population in the model, adults on first-line treatment.

Table 1 summarises these elements as well as the sources for their data, and indicate which of the following chapters contain further details on the estimation of the parameters.

**Table 1: Model elements and data sources for National ART Cost Model**

| Model element  | Categories of differentiation/ stratification levels                       | Data source  |
|--|--|--|
| Health states  | Age group, type of care <sup>1</sup> , regimens, CD4                       | Defined by differences in mortality in TLC data  |
| <b>Target population</b>   | Scenario, age group, CD4, year   |  |
| Number of adults initiating ART                                    |  | ASSA2003 (with relative rate of initiation at CD4 200-350 cells/microl based on AfA data)              |
| Number of children initiating ART                                  |  | ASSA2003 (with additional assumptions regarding scale-up of Early Paediatric Treatment)                |
| <b>Other epidemiological parameters</b>                            |  |  |
| Transition probabilities between health states                     | Age group, type of care <sup>1</sup> , CD4, time on treatment <sup>2</sup> | TLC/ HSCC data   |
| Mortality  |  | TLC/ HSCC data   |
| Loss to follow-up  |  | TLC/ HSCC data   |
| First-line treatment failure                                       |  | TLC/ HSCC data   |
| Switching from treatment failure to 2 <sup>nd</sup> line treatment | Age group, CD4, time in failure  |  |
| Incidence of side effects necessitating first-line drug change     | Age group, time on treatment   | TLC/ HSCC data   |
| <b>Cost parameters</b>   |  |  |
| Cost of HCT  | Age group  |  |
| Outpatient cost (adults)   | Scenario, type of care <sup>3</sup>  | CMH/ TWC data (see Chapter 5) + TLC data for treatment failure and second line                         |
| Inpatient cost (adults)  | Type of care <sup>4</sup> , CD4  | CHBH/ TH data (see Chapter 6)  |
| Outpatient cost (children)   | Scenario, age group, type of care <sup>5</sup>                             | HSCC/ ESRU data (see Chapter 7)  |
| Inpatient cost (children)  | Age group, type of care <sup>1</sup> , CD4                                 | CHBH/ TH data (see Chapter 6)<br>For separate analysis of inpatient cost in children <1, see Chapter 8 |

ASSA2003 Actuarial Society of South Africa AIDS Model 2003; AfA: Aid for AIDS; TLC Themba Lethu Clinic; HSCC Harriet Shezi Children's Clinic; CMH Charlotte Maxeke Hospital; TWC Tshepong Wellness Clinic; CHBH Chris Hani Baragwanath Hospital; TH Tintswalo Hospital; ESRU Empilweni Services and Research Unit

<sup>1</sup> First-line ART vs. first-line treatment failure vs. second-line ART

<sup>2</sup> For adult first-line population only

<sup>3</sup> Pre-ART vs. first-line ART vs. first-line treatment failure vs. second-line ART

<sup>4</sup> Pre-ART vs. ART only

## References

1. Mauskopf JA, Sullivan SD, Annemans L, Caro J, Mullins CD, Nuijten M, PhD, Orlewska E, Watkins J, Trueman T: Principles of Good Practice for Budget Impact Analysis: Report of the ISPOR Task Force on Good Research Practices - Budget Impact Analysis. *Value Health* 10(5):336-347 (2007)
2. Sullivan SD, Mauskopf JA, Augustovski F, Jaime Caro J, Lee KM, Minchin M, Orlewska E, Penna P, Rodriguez Barrios JM, Shau WY. Budget impact analysis-principles of good practice: report of the ISPOR 2012 Budget Impact Analysis Good Practice II Task Force. *Value Health*. 2014 Jan-Feb;17(1):5-14. doi: 10.1016/j.jval.2013.08.2291. Epub 2013 Dec 13.
3. Mauskopf J. Prevalence-based economic evaluation. *Value Health* 1, 251-259 (1998).
4. Trueman P, Drummond M, Hutton J: Developing guidance for budget impact analysis. *Pharmacoeconomics* 2001;19:609–621
5. World Health Organization. Scaling up antiretroviral therapy in resource-limited settings: guidelines for a public health approach. World Health Organization: Geneva, 2002
6. Antiretroviral therapy for HIV infection in infants and children: Towards universal access. Recommendations for a public health approach. 2010 revision. World Health Organization: Geneva, 2010
7. Youle M, Trueman P, Simpson K (1999) Health economics in HIV disease. A review of the European literature. *Pharmacoeconomics* 15 (Suppl 1): 1-12.
8. Beck EJ, Miners AH, Yolley K (2001) The cost of HIV treatment and care: a global review. *Pharmacoeconomics* 19: 13-39.
9. Beck EJ, Harling G, Gerbase S, DeLay P (2010) The cost of treatment and care for people living with HIV infection: implications of published studies, 1999–2008. *Curr Opin HIV AIDS* 5: 215-224.
10. Galárraga O, Wirtz VJ, Figuero-Lara A, Santa-Ana-Tellez Y, Coulibaly I (2011) Unit costs for delivery of antiretroviral treatment and prevention of mother-to-child transmission of HIV. A systematic review for low- and middle-income countries. *Pharmacoeconomics* 29: 579-99
11. Hutton G, Wyss K, N'Die'khor Y (2003) Prioritization of prevention activities to combat the spread of HIV/AIDS in resource constrained settings: a cost-effectiveness analysis from Chad, Central Africa. *Int J Health Plann Mgmt* 18: 117–136
12. Tran BX, Ohinmaa A, Duong AT, Nguyen LT, Vu PX, Mills S, Houston S, Jacobs P (2012) The cost-effectiveness and budget impact of Vietnam's methadone maintenance treatment programme in HIV prevention and treatment among injection drug users. *Glob Publ Health* 7:1080-94
13. Martin EG, Paltiel AD, Walensky RP, Schackman BR (2010) Expanded HIV Screening in the United States: What Will It Cost Government Discretionary and Entitlement Programs? A Budget Impact Analysis. *Value Health* 13:893-902
14. Anaya HD, Chan K, Karmarkar U, Asch SM, Goetz MB (2012) *Value Health* 15:1022-8
15. Chan K, Hernandez L, Yang H, Goetz MB (2014) Comparative Cost Analysis of Clinical Reminder for HIV Testing at the Veterans Affairs Healthcare System. *Value Health* 17:334-9

16. Mauskopf J, Tolson TM, Simpson KN, Pham SV, Albright J (2000) Impact of Zidovudine-based Triple Combination Therapy on an AIDS Drug Assistance Program. *J Acq Immune Defic Syndr* 23:302-13
17. Schackman BR, Freedberg KA, Goldie SJ, Weinstein MC, Swartz K (2005) Budget Impact of Medicaid Section 1115 Demonstrations for Early HIV Treatment. *Health Care Financ Rev* 26:67-80
18. Mills FP, Ford N, Nachega JB, Bansback N, Nosyk B, Yaya S, Mills EJ (2012) Earlier Initialization of Highly Active Antiretroviral Therapy Is Associated With Long-Term Survival and Is Cost-Effective: Findings From a Deterministic Model of a 10-Year Ugandan Cohort. *J Acquir Immune Defic Syndr* 61:364-9
19. Grupo de trabajo de la Cohorte VACH (2012) Impacto presupuestario del tratamiento antirretroviral. Reflexión desde las guías de GESIDA. *Gac Sanit* 26(6):541-6
20. Angeletti C, Pezzotti P, Antinori A, Mammone A, Navarra A, Orchi N, Lorenzini P, Mecozzi A, Ammassari A, Murachelli S, Ippolito G, Girardi E (2014) Antiretroviral treatment-based cost saving interventions may offset expenses for new patients and earlier treatment start. *HIV Medicine*, 15, 165–174
21. Oyagüez I, Casado MA, Cotarelo M, Ramírez-Arellano A, Mallolas J (2009) Budget impact of a set-dose combination of efavirenz-emtricitabine-tenofovir in the treatment of patients infected with HIV-1. *Farm Hosp* 33(5):247-56
22. Restelli U, Andreoni M, Antinori A, Bonfanti M, Di Perri G, Galli M, Lazzarin A, Rizzardini G, Croce D (2014) Budget impact analysis of antiretroviral less drug regimen simplification in HIV-positive patients on the Italian National Health Service. *ClinicoEconomics Outcomes Res* 6:409-14
23. Pasquau J, Gostkorszewicz J, Ledesma F, Anceau A, Hill A, Moecklinghoff C (2012) Budget Impact Analysis of Switching to Darunavir/Ritonavir Monotherapy for HIV-Infected People in Spain (Research letter). *Appl Health Econ Health Policy* 10(2):139-141
24. Colin X, Lafuma A, Costagliola D, Smets E, Mauskopf J, Guillon P (2010) Modelling the Budget Impact of Darunavir in the Treatment of Highly Treatment-Experienced, HIV-Infected Adults in France. *Pharmacoeconomics*; 28 Supp.1:183-97
25. Drummond M, O'Brien B, Stoddart G, Torrance G, Methods for the economic evaluation of health care programmes. 3rd ed. 2005, New York: Oxford University Press
26. World Health Organization. Antiretroviral therapy for HIV infection in infants and children: Towards universal access. Recommendations for a public health approach. 2010 revision. World Health Organization: Geneva, 2010.
27. World Health Organization. Consolidated guidelines on the use of antiretroviral drugs for treating and preventing HIV infection. Recommendations for a public health approach. Geneva, June 2013
28. Granich RM, Gilks CF, Dye C, De Cock KM, Williams BG (2009) Universal voluntary HIV testing with immediate antiretroviral therapy as a strategy for elimination of HIV transmission: a mathematical model. *Lancet* 373: 48–57.

29. Hontelez JAC, de Vlas SJ, Tanser F, Bakker R, Bärnighausen T, et al (2011) The Impact of the New WHO Antiretroviral Treatment Guidelines on HIV Epidemic Dynamics and Cost in South Africa. *PLoS ONE* 6:e21919.
30. Oddone E, Cowper P, Hamilton J, Matchar DB, Hartigan P, et al (1993) Cost effectiveness analysis of early zidovudine treatment of HIV infected patients. *Brit Med J* 307: 1322-5.
31. Schulman K, Lynne L, Glick H, Eisenberg J (1991) Cost-effectiveness of low-dose zidovudine therapy for asymptomatic patients with human immunodeficiency virus (HIV) infection. *Ann Intern Med* 114: 798-801.
32. Davies D, Carne C, Camilleri-Ferrante C (1999) Combined antiviral treatment in HIV infection. Is it value for money? *Publ Health* 113: 315-7.
33. Chancellor JV, Hill AM, Sabin CA, Simpson KN, Youle M (1997) Modelling the cost effectiveness of lamivudine/zidovudine combination therapy in HIV infection. *Pharmacoeconomics* 12(1): 54-66.
34. Mauskopf J, Lacey L, Kempel A, Simpson K (1998) The cost-effectiveness of treatment with lamivudine and zidovudine compared with zidovudine alone: a comparison of Markov model and trial data estimates. *Am J Manag Care* 4(7): 1004-12.
35. Simpson K, Hatziaureu EJ, Andersson F, Shakespeare A, Oleksy I et al (1994) Cost effectiveness of antiviral treatment with zalcitabine plus zidovudine for AIDS patients with CD4+ counts less than 300/microliters in 5 European countries. *Pharmacoeconomics* 6(6): 553-62.
36. Biddle AK, Simpson KN (2000) Modeling the use of triple combination therapy in five countries: nevirapine, zidovudine, and didanosine. *Value in Health* 3(3): 186-201.
37. Sendi PP, Bucher H, Harr T, Craig BA, Schwieter M (1999) Cost effectiveness of highly active antiretroviral therapy in HIV-infected patients. *AIDS* 13: 1115-22.
38. Cook J, Dasbach E, Coplan P, Markson L, Yin D, et al (1999) Modeling the long-term outcomes and costs of HIV antiretroviral therapy using HIV RNA levels: applications to a clinical trial. *AIDS Res Human Retroviruses* 15(6): 499-508.
39. Trueman P, Youle M, Sabin CA, Miners AH, Beck EJ (2000) The cost-effectiveness of triple nucleoside analogue therapy antiretroviral regimens in the treatment of HIV in the United Kingdom. *HIV Clin Trials* 1(1): 27-35.
40. Miners A, Sabin C, Trueman P, Youle M, Mocroft A, et al (2001) Assessing the cost-effectiveness of highly active antiretroviral therapy for adults with HIV in England. *HIV Medicine* 2: 52-8.
41. Kahn JG, Haile B, Kates J, Chang S (2001) Health and federal budgetary effects of increasing access to antiretroviral medications for HIV by expanding Medicaid. *Am J Public Health* 91(9):1464-73.
42. Risebrough N, Oh P, Rachlis A, McMurchy D, Bast M, et al (1999) Economic Evaluation of Triple ART with Indinavir or Abacavir and ZDV+3TC Compared to Dual Therapy ZDV+3TC. 6th Conference on Retroviruses and Opportunistic Infections.
43. Caro J, O'Brien J, Miglaccio-Walle K, Raggio G (2001) Economic analysis of initial HIV treatment: efavirenz- versus indinavir-containing triple therapy. *Pharmacoeconomics* 19: 95-104.

44. Schackman BR, Freedberg KA, Weinstein MC, Sax PE, Losina E, et al (2002) Cost-effectiveness implications of the timing of antiretroviral therapy in HIV-infected adults. *Arch Intern Med* 162(21): 2478-86.
45. Schackman BR, Goldie SJ, Weinstein MC, Losina E, Zhang H, et al (2001) Cost-effectiveness of earlier initiation of antiretroviral therapy for uninsured HIV-infected adults. *Am J Public Health* 91(9): 1456-63.
46. Yazdanpanah Y, Goldie S, Losina E, Weinstein MC, Lebrun T, et al (2002) Lifetime cost of HIV care in France during the era of highly active antiretroviral therapy. *Antivir Therapy* 7: 257-266.
47. Freedberg KA, Losina E, Weinstein MC, Paltiel D, Cohen C, Seage G, et al (2001) The cost effectiveness of combination antiretroviral therapy for HIV disease. *N Engl J Med* 344: 824-31.
48. Mauskopf JA, Tolson JM, Simpson KN, Pham SV, Albright J (2000) Impact of zidovudine-based triple combination therapy on an AIDS drug assistance program. *JAIDS* 23(4): 302-313.
49. Moore RD, Bartlett J (1996) Combination antiretroviral therapy in HIV infection: an economic perspective. *Pharmacoeconomics* 10: 109-13.
50. Simpson KN, Luo MP, Chumney E, Sun E, Brun S, Ashraf T (2004) Cost-Effectiveness of Lopinavir/Ritonavir Versus Nelfinavir As the First-Line Highly Active Antiretroviral Therapy Regimen for HIV Infection. *HIV Clin Trials* 5(5): 294-304.
51. Munakata J, Sanders G, Owens D, Bayoumi A (2003) Cost effectiveness of enfuvirtide in the treatment of drug-resistant HIV infection. *Med Decis Making* 23: 569.
52. Snedecor S, Hartzema A, Schiller K (2005) Cost effectiveness of HIV treatment innovations of greater efficacy than highly active antiretroviral therapy (HAART). *Value in Health* 8(3): 244.
53. Sax P, Losina E, Weinstein M, Paltiel A, Goldie S, et al (2005) Cost-effectiveness of enfuvirtide in treatment-experienced patients with advanced HIV disease. *JAIDS* 39(1): 69-77.
54. Long E, Brandeau M, Galvin C, Vinichenko T, Tole S, et al (2006) Effectiveness and cost-effectiveness of strategies to expand antiretroviral therapy in St. Petersburg, Russia. *AIDS* 20: 2207-15.
55. Goldie S, Yazdanpanah Y, Losina E, Weinstein M, Anglaret X, et al (2006) Cost-effectiveness of HIV treatment in resource-poor settings--the case of Cote d'Ivoire. *N Engl J Med* 355(11): 1141-53.
56. Paton N, Chapman C, Sangeetha S, Mandalia S, Bellamy R, et al (2006) Cost and cost-effectiveness of antiretroviral therapy for HIV infection in Singapore. *Int J STD AIDS* 17(10):699-705.
57. Cleary S, McIntyre D, Boule A (2006) The cost-effectiveness of antiretroviral treatment. *Cost Effectiveness and Resource Allocation* 4: 20.
58. Over M, Revenga A, Msasaki E, Peerapatanapokin W, Gold J, et al (2007) The economics of effective AIDS treatment in Thailand. *AIDS* 21(Suppl 4): S105-16.
59. Walensky RP, Wood R, Ciaranello AL, Paltiel AD, Lorenzana SB, et al (2010) Scaling Up the 2010 World Health Organization HIV Treatment Guidelines in Resource-Limited Settings: A Model-Based Analysis. *PLoS Med* 7(12): e1000382.

60. Bendavid E, Grant P, Talbot A, Owens DK, Zolopa A (2011) Cost-effectiveness of antiretroviral regimens in the World Health Organization's treatment guidelines: a South African analysis. *AIDS* 25: 211–220.
61. Ciaranello AL, Lockman S, Freedberg KA, Hughes M, Chu J, et al (2011) First-line antiretroviral therapy after single-dose nevirapine exposure in South Africa: a cost-effectiveness analysis of the OCTANE trial. *AIDS* 25:479–492.
62. Bachmann MO (2006) Effectiveness and cost effectiveness of early and late prevention of HIV/AIDS progression with antiretrovirals or antibiotics in Southern African adults. *AIDS Care* 18(2): 109-120.
63. Long EF, Brandeau ML, Owens DK (2010) The Cost-Effectiveness and Population Outcomes of Expanded HIV Screening and Antiretroviral Treatment in the United States. *Ann Intern Med* 153: 778-789.
64. Over M, Heywood P, Gold J, Gupta I, Hira S, Marseille E (2004) HIV/AIDS treatment and prevention in India: Modeling the costs and consequences. Washington, D.C.: The International Bank for Reconstruction and Development/ The World Bank.
65. Vijayaraghavan A, Efrusy MB, Mazonson PD, Ebrahim O, Sanne IM, et al (2007) Cost effectiveness of alternative strategies for initiating and monitoring highly active antiretroviral therapy in the developing world. *J Acquir Immune Defic Syndr* 46(1): 91-100.
66. Bonnel R (2000) Costs of scaling HIV program activities to a national level in sub-Saharan Africa: Methods and estimates. Washington D.C.: World Bank.
67. Kumaranayake L, Conteh L, Kurowski C, Watts C (2001) Preliminary estimates of the cost of expanding TB, malaria and HIV/AIDS activities for sub-Saharan Africa. Geneva: Working Group 5, WHO Commission on Macroeconomics and Health.
68. Creese A, Floyd K, Alban A, Guinness L (2002) Cost-effectiveness of HIV/AIDS interventions in Africa: a systematic review of the evidence. *Lancet* 359: 1635-42.
69. Hogan DR, Baltussen R, Hayashi C, Lauer JA, Salomon JA (2005) Achieving the millennium development goals for health: Cost effectiveness analysis of strategies to combat HIV/AIDS in developing countries. *Brit Med J*, doi:10.1136/bmj.38643.368692.68
70. Floyd K, Gilks C (1997) Cost and financing aspects of providing antiretroviral therapy. In: Van Praag E, Fernyak S, Martin Katz A, eds. The implications of antiretroviral treatments. Informal Consultation. World Health Organization, Office of HIV/AIDS and Sexually Transmitted Diseases. Geneva: WHO.
71. Hogg R, Weber A, Craib K, Aslam A, O'Shaughnessy M, et al (1998) One world, one hope: the cost of providing antiretroviral therapy to all nations. *AIDS* 12: 2203-9.
72. Attaran A, Sachs J (2001) Defining and refining international donor support for combating the AIDS epidemic. *Lancet* 357: 57-61
73. Schwartländer B, Stover J, Walker N, Bollinger L, McGreevey W, et al (2001) Resource needs for HIV/AIDS. *Science* 292(5526): 2434-6.
74. Gutierrez J, Johns B, Adam T, Bertozzi SM, Edejer TT (2004) Achieving the WHO/UNAIDS antiretroviral treatment 3 by 5 goal: what will it cost? *Lancet* 364: 63-4.



75. Stover J, Korenromp E, Blakley M, Komatsu R, Viisainen K (2011) Long-Term Costs and Health Impact of Continued Global Fund Support for Antiretroviral Therapy. *PLoS ONE* 6(6): e21048.
76. Resch S, Korenromp E, Stover J, Blakley M, Krubiner C, et al (2011) Economic Returns to Investment in AIDS Treatment in Low and Middle Income Countries. *PLoS ONE* 6(10): e25310.
77. Schwartländer B, Stover J, Hallett T, Atun R, Avila C, Gouws E, et al (2011) Towards an improved investment approach for an effective response to HIV/AIDS. *Lancet* 377: 2031–41
78. Rosen S, Long L, Fox M, Sanne I: Cost and cost-effectiveness of switching from stavudine to tenofovir in first-line antiretroviral regimens in South Africa. *J Acquir Immune Defic Syndr* 2008;48(3):334-44.
79. Rosen S, Long L, Sanne I: The outcomes and outpatient costs of different models of antiretroviral treatment delivery in South Africa. *Trop Med Int Health* 2008;13(8):1005-15
80. Long L, Fox M, Sanne I, Rosen S: The high cost of second-line antiretroviral therapy for HIV/AIDS in South Africa. *AIDS* 2010,24(6):915-9
81. Leisegang R, Cleary S, Hislop M, et al: Early and late direct costs in a Southern African antiretroviral treatment programme: A retrospective cohort analysis. *PLoS Med* 2009 6(12)
82. Badri M, Cleary S, Maartens G, et al: When to initiate highly active antiretroviral therapy in sub-Saharan Africa? A South African cost-effectiveness study. *Antivir Ther* 2006;11(1):63-72
83. Harling G, Wood R: The evolving cost of HIV in South Africa. *JAIDS* 2007;45:348-54.
84. Martinson N, Mohapi L, Bakos D, et al. Costs of providing care for HIV-infected adults in an urban HIV clinic in Soweto, South Africa. *JAIDS* 2009;50: 327-30
85. Stearns BK, Evans DK, Lutung P, et al. Primary estimates of the costs of ART care at 5 AHF clinics in sub-Saharan Africa [MOPE0706]. Presented at: XVIIth International AIDS Conference; 2008; Mexico City.
86. Kevany S, Meintjes G, Rebe K, et al: Clinical And Financial Burdens of Secondary Level Care In A Public Sector Antiretroviral Roll-out Setting (G F Jooste Hospital). *S Afr Med J.* 2009;99:320-25.
87. Smith de Cherif TK, Schoeman JH, Cleary S, et al: Early severe morbidity and resource utilization in South African adults on antiretroviral therapy. *BMC Inf Dis* 2009;9:205.
88. Thomas LS, Manning A, Holmes CB, et al: Comparative Costs of Inpatient Care for HIV-Infected and Uninfected Children and Adults in Soweto, South Africa. *JAIDS* 2007;46:410-6.
89. Granich RM, Gilks CF, Dye C, De Cock KM, Williams BG: Universal voluntary HIV testing with immediate antiretroviral therapy as a strategy for elimination of HIV transmission: a mathematical model. *Lancet* 2009;373(9657):48-57
90. Walensky RP, Wolf LL, Wood R et al for the CEPAC (Cost-Effectiveness of Preventing AIDS Complications)-International Investigators: When to Start Antiretroviral Therapy in Resource-Limited Settings. *Ann Int Med* 2009;151:157-166
91. Walensky RP, Wood R, Ciaranello AL, Paltiel AD, Lorenzana SB, Anglaret X, et al for the CEPAC-International Investigators: Scaling Up the 2010 World Health Organization HIV Treatment Guidelines in Resource-Limited Settings: A Model-Based Analysis. *PLoS Med* 2010;7(12): e1000382. doi:10.1371/journal.pmed.1000382

92. Bendavid E, Grant P, Talbot A, Owens DK, Zolopa A (2011) Cost-effectiveness of antiretroviral regimens in the World Health Organization's treatment guidelines: a South African analysis. *AIDS* 25: 211–220.
93. Ciaranello AL, Lockman S, Freedberg KA, Hughes M, Chu J, et al (2011) First-line antiretroviral therapy after single-dose nevirapine exposure in South Africa: a cost-effectiveness analysis of the OCTANE trial. *AIDS* 25:479–492.
94. Bachmann MO (2006) Effectiveness and cost effectiveness of early and late prevention of HIV/AIDS progression with antiretrovirals or antibiotics in Southern African adults. *AIDS Care* 18(2): 109-120.
95. Hontelez JAC, de Vlas SJ, Tanser F, Bakker R, Bärnighausen T, et al (2011) The Impact of the New WHO Antiretroviral Treatment Guidelines on HIV Epidemic Dynamics and Cost in South Africa. *PLoS ONE* 6:e21919.

## Appendix to chapter 4

NB, this appendix uses the same references as the main text of Chapter 4.

**Table 1: Summary of details and findings of reviewed budget impact analyses**

| First author, year  | Country | Intervention                        | Stand-alone BIA or combination | Purpose  | Findings  |
|---------------------|---------|-------------------------------------|--------------------------------|--|---|
| Hutton 2003 [11]    | Chad    | HIV prevention                      | BIA + CEA                      | evaluates the BI of prevention activities compared to ART  | "most cost-effective preventive options do not require large budgets, with the most expensive intervention being the education of high risk groups at around US\$1 million annually"<br>"the total budget requirements of all the recommended preventive options is US\$3.2 million annually, and rises to US\$3.8 million when the strategies 'to be considered' are included" |
| Tran 2012 [12]      | Vietnam | Methadone replacement therapy (MRT) | BIA + CEA                      | CEA and BIA of MRT in HIV prevention and treatment (BIA from 2011 to 2015)   | BI is \$97 million over 5 yrs (at 65% coverage) or \$49 m for 80,000 IDUs; ce at 3 GDP pc   |
| Martin 2010 [13]    | US      | Expanded HCT                        | BIA                            | BI of expanded testing (every 5 instead of every 10 years) to "US government discretionary [Ryan White Act funding, in part via ADAPs], entitlement [Medicare and Medicaid], and separate testing programs" over 5 yrs   | incremental cost over 5 yrs \$2.7 billion for 46,000 additional cases; most budget increases from treatment (testing only 18% of total budget increase)   |
| Anaya 2012 [14]     | US      | Expanded HCT                        | BIA                            | BI of increasing coverage with routinely offered HCT in VA system from 2% to 15% per year, and offering ART to people found to be HIV+   | additional BI \$290,000 over 2 yrs, for 21 new HIV infections identified  |
| Chan 2014 [15]      | US      | HCT reminder                        | BIA + CEA (cost per test)      | BIA and CEA of "clinical reminders with telephone notifications for negative results" with and without "nurse-based streamlined pre-test counseling" and either risk-based or routine and either required or just "recommended" post-test counselling for HIV+ | \$81,726 over 1 year; cost per new diagnosis lowest under reminder system without pre-test counselling  |
| Mauskopf 2000 [16]  | US      | HAART vs. monotherapy               | BIA                            | effect on NY state ADAP programme of shift from monotherapy to HAART   | ART costs alone would increase by 115%, though all would be recouped by savings in OI costs, resulting in a net decrease of 0.4%  |
| Schackman 2005 [17] | US      | Early ART (CD4 > 200 cells/microl)  | BIA                            | test whether Section 1115 demonstrations applications by Georgia (stand-alone 5-yr cost  | Neither demonstration project would meet the 5-year test of "no increase in federal spending over and above what would be   |

| First author, year                            | Country | Intervention   | Stand-alone BIA or combination | Purpose  | Findings  |
|---|---------|--|--------------------------------|--|---|
| Mills 2012 [18]                               | Uganda  | Early ART (350 vs. 200)  | BIA + CEA                      | can't exceed Medicaid budget) and Mass. (cost can't exceed budget surplus for project over 2 yrs) don't exceed allocated Medicaid budget<br>CEA and BIA of 2010 WHO GL (eligibility at 350 CD4) over current GL (eligibility at 200 CD4), over 5 and 30 yrs, at current levels of coverage (53%) | expected in absence of demonstration project"; limitation: potentially 5 years too short a horizon<br>53% coverage of the eligible population will cost an additional \$261,651,942 over 5 yrs, and \$872,685,561 over 30 yrs ICERs suggest highly cost-effective (as below GDP per capita) |
| Grupo de trabajo de la Cohorte VACH 2012 [19] | Spain   | ART eligibility at 500 (vs. 350) + clinical and age criteria for initiation >500 | BIA                            | BIA of applying new (2011) Spanish GL with eligibility at 500  | GL application would increase ARV cost in VACH cohort hospitals by €3,270,975, or 3%, over 1 yr   |
| Angeletti 2014 [20]                           | Italy   | Eligibility at 500 CD4 and cost-saving measures                                  | Cost and BIA                   | analyse short and medium-term cost trends resulting from 2011 GL on "on the costs of treating an HIV-infected population over the period 2012–2016" in the Lazio region  | earlier initiation increase budget for HIV in Lazio region by 2.3%; increasing NNRTI-based regimens in new starters from 27% to 50% reduces budget by 0.3%; single tablet regimens and PI/r-based monotherapy saves 1.5%; introducing generics saves a further 3.3%                         |
| Oyagüez 2009 [21]                             | Spain   | EFV-FTC-TDF FDC  | BIA                            | estimate the BI of substituting different first-line regimens with EFV-FTC-TDF FDC   | incremental cost would be between -1.99 and +6.73% of current budget over 1 yr, based on the replacement scenario chosen  |
| Restelli 2014 [22]                            | Italy   | 'Less-drug regimen' ART  | BIA                            | BI of PI-based dual and monotherapies over current regimen mix over 3 yrs  | ART expenditure would drop by 6.7% and 12.8% in the examined hospitals, or 1.1%-2.1% in the Italian National Health Service   |
| Pasquau 2012 [23]                             | Spain   | DRV/r  | BIA                            | BIA of switching the 15% of Spanish ART pts who are currently on 2 NRTI + PI or NNRTI to DRV/r +/- 2 NRTI, with resource use based on MONET trial  | switch to DRV/r saves €62 m over 3 yrs  |
| Colin 2010 [24]                               | France  | DRV/r vs. TPV/r  | BIA                            | evolution of ARV and non-ARV cost over 3 yrs under scale-up of DRV/r from 20% to 70% coverage for highly treatment-experienced pts   | net saving of €11.4 m (2.9% of total budget) with DVR/r, mostly from preventing lower CD4 and associated hosp costs   |

**Table 2: Summary of methods of reviewed budget impact analyses: Perspective**

| First author, year  | Country | Intervention                        | Perspective  | For this perspective,<br>...relevant target population?   | ...relevant current and expected<br>new treatment mix?  | ...relevant resource use and cost?   |
|---------------------|---------|-------------------------------------|--|---|---|--|
| Hutton 2003 [11]    | Chad    | HIV prevention                      | government   | yes (based on EpiModel)   | not enough information  | no (mostly literature)   |
| Tran 2012 [12]      | Vietnam | Methadone replacement therapy (MRT) | health-care system   | yes   | yes, though capped at current population  | no (MMT costed comprehensively, but for ART, cost limited to ARV drugs only)   |
| Martin 2010 [13]    | US      | Expanded HCT                        | RW and Medicaid/ -care funders (5-yr horizon reflects "the 3 to 5-year interval typical of RW reauthorizations") | yes (only paper to give reason for exclusion of children, as funded differently, and including treatment, but excluding testing costs for the elderly, as these not part of current GL); based on national prevalence and incidence estimates (incidence assume constant) | yes   | yes (testing and treatment; for testing, great level of detail incl. admin cost for "nonreturn for results" etc)                       |
| Anaya 2012 [14]     | US      | Expanded HCT                        | payer (Veterans Healthcare Administration)   | yes   | yes   | yes (including comprehensively costed ART)   |
| Chan 2014 [15]      | US      | HCT reminder                        | payer (Veterans Healthcare Administration)   | yes   | yes   | no- no ART or other care costs included  |
| Mauskopf 2000 [16]  | US      | HAART vs. monotherapy               | ADAP   | somewhat- though cohort size seems to be based on past data (no mortality benefit of triple tx?)  | yes- all on monotherapy are switched to triple tx   | yes  |
| Schackman 2005 [17] | US      | Early ART (CD4 > 200 cells/microl)  | payer (Medicaid)   | yes (newly identified uncovered individuals)  | yes (no waiver vs waiver scenarios with annual cohorts tracked over 5 years, with careful delineation of payers (ADAP vs Medicaid vs "other") in either scenario) | yes (non-drug cost based on ACSUS and BMC accounting system and adjusted for differences between States, and comparable to other data) |
| Mills 2012 [18]     | Uganda  | Early ART (350 vs. 200)             | ministry of health   | not sure- seems limited to closed cohort  | to some extent (impact on TB, but no other OIs)   | yes  |

| First author, year                            | Country | Intervention   | Perspective                                 | For this perspective,  |  |   |
|---|---------|--|---|--|--|---|
|   |         |  |   | ...relevant target population?   | ...relevant current and expected new treatment mix?                      | ...relevant resource use and cost?  |
| Grupo de trabajo de la Cohorte VACH 2012 [19] | Spain   | ART eligibility at 500 (vs. 350) + clinical and age criteria for initiation >500 | "perspective of pharmaceutical expenditure" | limited to one clinical cohort spanning several hospitals  | no (distribution into regimes based on current cohort)                   | no (cost limited to ARV cost)   |
| Angeletti 2014 [20]                           | Italy   | Eligibility at 500 CD4 and cost-saving measures                                  | Lazio Regional Health System                | yes (including current regional cohort and modelled incidence and testing/ treatment coverage)   | yes  | yes (including hospital admissions, ARV and non-ARV drugs, outpatient visits and lab tests) |
| Oyagüez 2009 [21]                             | Spain   | EFV-FTC-TDF FDC  | "hospital"                                  | yes (based on national AIDS registry, inflated for non-registered case based on survey of hospitals, corrected for eligibility (CD4<35) and current coverage (83.2%) based on same survey; added assumed new cases)                | yes  | no (ARV costs only)   |
| Restelli 2014 [22]                            | Italy   | 'Less-drug regimen' ART  | National Health Service                     | yes (includes reasonable new entries and exits)  | yes (4 possible scenarios)   | no (only ARV drug cost included)  |
| Pasquau 2012 [23]                             | Spain   | DRV/r  | not mentioned                               | yes  | no (limited to those options included in 1 trial)                        | no (only ARV costs)   |
| Colin 2010 [24]                               | France  | DRV/r vs. TPV/r  | public healthcare system                    | yes- "highly treatment-experienced, HIV-infected adults who have failed more than one PI-containing regimen" only, based on data covering 50-60% of French ART pts and multiplied out to all of France's HIV pos (4.6% of 130,000) | yes (including a change in treatment regimens in the baseline scenario!) | yes (including non-ARV and inpatient costs)   |

**Table 3: Summary of methods of reviewed budget impact analyses: Analytical framework**

| First author, year                            | Analytical framework for BIA                                   | Analytical framework for CEA or cost analysis         | If simulation model,  |   |   |
|---|--|---|---|---|---|
|   |  |   | ...is assumption of changes in total population, disease severity or treatment pattern warranted?   | ...are all health outcomes for affected population included?  | ...are all costs for affected population included?  |
| Hutton 2003 [11]                              | calculator   | EpiModel + cost                                       |   |   |   |
| Tran 2012 [12]                                | decision-tree model  | decision-tree model; epi: Modes of Transmission model | no (model only run for 1 yr, then population assumed to be constant over 5 yrs, with coverage increasing from to 70%)   | yes   | no (MMT costed comprehensively, but for ART, cost limited to ARV drugs only)  |
| Martin 2010 [13]                              | CEPAC model  |   | yes   | yes   | yes (testing, treatment and routine care); no pre-test counselling as not part of current GL (and also varies by state) |
| Anaya 2012 [14]                               | dynamic model  |   | yes   | no (ART and HCT only, no other outcomes)  | no (ART and HCT only, no other costs)   |
| Chan 2014 [15]                                | decision tree  |   | yes   | no (HCT outcomes only)  | no (HCT costs only)   |
| Mauskopf 2000 [16]                            | static deterministic model                                     |   | no (OI incidence only, looks like mortality set to be same between arms)  | no (OI incidence only, looks like mortality set to be same between arms)  | yes (OI treatment and prophylaxis, ARVs, PCR monitoring for triple tx)  |
| Schackman 2005 [17]                           | "state-transition" simulation model (precursor to CEPAC model) |   | yes   | yes   | yes   |
| Mills 2012 [18]                               | Markov model   |   | yes (apart from crude approximation of prevention benefit of ART)   | no (only TB)  | yes   |
| Grupo de trabajo de la Cohorte VACH 2012 [19] | calculator   |   |   |   |   |
| Angeletti 2014 [20]                           | deterministic health-state transition model                    |   | yes   | yes   | yes (including hospital admissions, ARV and non-ARV drugs, outpatient visits and lab tests)                             |
| Oyagüez 2009 [21]                             | calculator   |   |   |   |   |
| Restelli 2014 [22]                            | simple BI model  |   |   |   |   |
| Pasquau 2012 [23]                             | calculator   |   |   |   |   |
| Colin 2010 [24]                               | health-state transition model                                  |   | no (in the comparator scenario, most pts with PI resistance would be given TPV/r instead which was not available in France at the time- might have led to an underestimation of savings?) | yes (although use of trial data only might have overestimated the beneficial impact on CD4 cell count development, and do not include longer-term outcomes or side effects) | yes (including non-ARV and inpatient costs)   |

**Table 4: Summary of methods of reviewed budget impact analyses: Impact on access and uptake**

| First author, year                            | Impact on access and uptake  |  |  |
|---|--|--|--|
|   | Are potential access restrictions included?                              | Is the potential uptake included?                                | Are the use and effects of both the new intervention and current interventions that might be replaced included?  |
| Hutton 2003 [11]                              | no   | not enough information   | no- full analysis (ie, comparator is "do nothing")   |
| Tran 2012 [12]                                | yes (coverage capped at 70%)   | no (modelled over 1 yr only)                                     | no (MMT costed comprehensively, but for ART, cost limited to ARV drugs only)   |
| Martin 2010 [13]                              | yes (only non-privately insured and non-VA pts)                          | yes  | yes (incl. treatment and routine care)   |
| Anaya 2012 [14]                               | no   | yes  | yes  |
| Chan 2014 [15]                                | no   | yes  | no (HCT cost only)   |
| Mauskopf 2000 [16]                            | yes  | yes- coverage increased from 66% for monox to 100% for triple tx | yes  |
| Schackman 2005 [17]                           | yes  | yes  | yes  |
| Mills 2012 [18]                               | no (coverage tagged to current level, 53%)                               | no   | yes- though somewhat limited by having limited entry population  |
| Grupo de trabajo de la Cohorte VACH 2012 [19] | coverage of GL set to 80%  | no, only over 1 yr   | no- assumes same distribution into regimens as current cohort  |
| Angeletti 2014 [20]                           | no restrictions  | yes- coverage is between 20 and 85%, by CD4 stratum              | yes  |
| Oyagüez 2009 [21]                             | no   | yes  | no (ARV costs only)  |
| Restelli 2014 [22]                            | yes, through some scenarios  | yes, through some scenarios                                      | no (effects not fully considered as only ARV drug costs, no SE or hosp. cost)  |
| Pasquau 2012 [23]                             | no   | no   | no   |
| Colin 2010 [24]                               | yes- target population are highly experienced pts with PI mutations only | yes  | yes (with the exception that in the comparator scenario, most pts with PI resistance would be given TPV/r instead which was not available in France at the time- might have led to an underestimation of savings?) |



**Table 5: Summary of methods of reviewed budget impact analyses: Uncertainty analysis**

| First author, year                            | Uncertainty analysis     | Sensitivity analysis? | If sensitivity analysis,                              |  | Scenario analysis?  | If scenario analysis, are plausible alternative input parameters included |  | If scenario analysis, are plausible alternative structural assumptions included? |
|---|--------------------------|-----------------------|---|--|---|---|--|--|
|   |                          |                       | ...is parameter uncertainty in input values included? | ...is structural uncertainty in choice of analytical framework included? |   | ...for cost?  | ...for outcomes?   |  |
| Hutton 2003 [11]                              | yes (based on EpiModel)  | yes                   | yes   | no   | no  |   |  |  |
| Tran 2012 [12]                                | yes                      | yes                   | yes (PSA)   | no   | no  |   |  |  |
| Martin 2010 [13]                              | yes                      | yes                   | yes   | yes (10- instead of 5-yr modelling framework)                            | no  |   |  |  |
| Anaya 2012 [14]                               | yes                      | yes                   | yes   | no   | no  |   |  |  |
| Chan 2014 [15]                                | yes                      | yes                   | yes   | no   | no  |   |  |  |
| Mauskopf 2000 [16]                            | yes                      | yes                   | yes   | no   | no  |   |  |  |
| Schackman 2005 [17]                           | yes                      | yes                   | yes   | no   | yes (and if initiation was according to GL in base case in both states) | somewhat (20% reduction in drug costs, but no other costs tested)         | somewhat (tested what would happen if enrolment was capped in both states) | no   |
| Mills 2012 [18]                               | yes                      | yes                   | yes   | to some extent (inclusion of productivity impact)                        | no  |   |  |  |
| Grupo de trabajo de la Cohorte VACH 2012 [19] | no                       |                       |   |  | no  |   |  |  |
| Angeletti 2014 [20]                           | yes                      | yes                   | yes   | no restrictions  | no  |   |  |  |
| Oyagüez 2009 [21]                             | yes (univariate +/- 20%) | yes                   | yes   | no   | no  |   |  |  |
| Restelli 2014 [22]                            | yes                      | yes                   |   |  | yes- 4 scenarios of differing coverage and eligibility                  | no  | no   | no   |
| Pasquau 2012 [23]                             | no                       |                       |   |  | no  |   |  |  |
| Colin 2010 [24]                               | yes (one-way)            | yes                   | yes   | no   | no  |   |  |  |

**Table 6: Economic evaluations for single countries**

| First author, year   | Country                                 | Aim and intervention(s)  | Modelling method; time horizon    | Perspective | Measure                             | Result in 2011 USD   | Factors influencing input cost (including in sensitivity analysis, SA) <sup>6</sup>  |
|----------------------|---|--|-----------------------------------|-------------|-------------------------------------|--|--|
| Oddone 1993 [30]     | US                                      | Incremental cost effectiveness of early (at recruitment) vs. late (at 200 CD4 cells/microl) initiation of ZDV monotherapy (1500 mg vs. 500 mg per day) | Markov; 4 years                   | Provider    | Cost per month without AIDS         | \$17,944 (1500 mg); \$6,538 (500 mg)   | Health state;<br>SA: ZDV dosage  |
| Schulman 1991 [31]   | US                                      | Incremental cost effectiveness of ZDV monotherapy over no treatment  | Health state transition; lifetime | Provider    | Cost per life year saved            | \$9,027 (when continuous benefit is assumed) to \$84,882 (when one-time benefit is assumed)    | Constant cost in main analysis;<br>SA: ZDV cost +/- 50%; lifetime cost in AIDS state +/- 50%   |
| Davies 1999 [32]     | UK                                      | Incremental cost effectiveness of ZDV+3TC over ZDV alone in 2 different London clinics   | Markov; 25 years                  | Provider    | Cost per life year saved            | \$14,400 to \$32,171   | Regimen, health state (CD4 200   500 cells/microl);<br>no SA   |
| Chancellor 1997 [33] | UK                                      | Full and incremental cost effectiveness of ZDV and ZDV+3TC   | Markov; 20 years                  | Provider    | Cost per life year saved            | \$13,781 (ZDV, full)<br>\$17,330 (3TC incremental over ZDV)                                    | Regimen, health state (CD4 200   AIDS);<br>SA: Community cost included   |
| Mauskopf 1998 [34]   | US                                      | Incremental cost effectiveness of 3TC+ZDV over ZDV alone   | Markov; lifetime                  | Provider    | Cost per life year saved / per QALY | \$14,918 to \$26,852/<br>\$20,885 to \$40,279  | Regimen, health state (CD4 100   200   350   500);<br>SA: Cost not included  |
| Simpson 1994 [35]    | France, Germany, Italy, Switzerland, UK | Incremental cost effectiveness of ddC+ZDV over ZDV alone   | Markov; 1 year                    | Provider    | Cost per life year saved            | \$27,741 (France), \$37,154 (Germany), \$25,275 (Italy), \$31,374 (Switzerland), \$42,944 (UK) | Regimen, incidence of opportunistic infections (OI) and AIDS-defining disease (ADD) by CD4 (no details on CD4 categories);<br>SA: Future cost +/- 50%, OI/ ADD incidence +/- 50% |

<sup>6</sup> For health states, the notation "CD4 200 | 350" denotes the cut-off values between CD4 cell count categories; the corresponding categories would be <200, 200-350, and >350 cells/microl

| First author, year | Country                           | Aim and intervention(s)   | Modelling method; time horizon   | Perspective                 | Measure  | Result in 2011 USD   | Factors influencing input cost (including in sensitivity analysis, SA) <sup>6</sup>  |
|--------------------|-----------------------------------|---|--|-----------------------------|--|--|--|
| Biddle 2000 [36]   | France, Germany, Italy, Spain, US | Incremental cost effectiveness of NVP-containing triple therapy over dual therapy | Markov (based on Simpson 1994 (6) and Chancellor 1997 (4)); 1 year/ 15 years | Provider and patient        | Cost per life year saved   | \$24,509 (France), \$25,070 (Germany), \$23,328 (Italy), \$12,507 (Spain), \$20,376 (US)   | 1 year analysis: same as Simpson 1994 (6)<br>15-year analysis: modified from Chancellor 1997 (4): Regimen, health state (CD4 200   500   AIDS);<br><br>SA: Admission rates in Italy set to be the same as in Spain   |
| Sendi 1999 [37]    | Switzerland                       | Incremental cost effectiveness of HAART over non-HAART                            | Markov; lifetime   | 1. Provider,<br>2. Societal | Cost per life year saved   | 1. (provider perspective):<br>\$71,111 (pessimistic scenario),<br>\$42,149 (base case),<br>\$22,124 (optimistic scenario)<br>2. (societal perspective):<br>\$17,383 (pessimistic scenario),<br>cost savings in base case and optimistic scenario | Health state (CD4 200   500, both with and without AIDS);<br><br>SA: 95% confidence intervals around all estimates (probabilistic SA)  |
| Cook 1999 [38]     | US                                | Incremental cost effectiveness of ZDV+3TC+IDV over ZDV+3TC                        | Health state transition with semi-Markov model; 5/ 20 years                  | Provider                    | Cost per life year saved   | \$19,174   | Regimen, health state (CD4 200   500   AIDS); ART given until VL returns to baseline;<br>SA: Different set of cost estimates (but same CD4 categories); ART given until time of index ADD or death   |
| Trueman 2000 [39]  | UK                                | Incremental cost effectiveness of triple over dual NRTI therapy                   | Markov (same as Chancellor 1997 (4)); 20 years                               | Provider                    | Cost per life year saved/ per QALY   | \$17,217/<br>\$20,598 (optimistic scenario),<br>\$33,064 (pessimistic scenario)  | Regimen, health state (CD4 200   AIDS);<br><br>SA: Time horizon 5 years only   |
| Miners 2001 [40]   | UK                                | Incremental cost effectiveness of HAART over dual NRTI                            | Markov; 20 years   | Provider                    | Cost per life year saved/ per QALY   | \$35,897/ \$43,508   | Regimen, health state (CD4 200   AIDS) and time on treatment (first year vs consecutive years);<br>SA: Increase in cost of third drug; time horizon 10 years   |
| Kahn 2001 [41]     | US                                | Incremental cost effectiveness of increased access to HAART by expanding Medicaid | Markov; 5 years  | Provider                    | Cost per life year saved with limited benefits package (drugs and outpatient care) | \$17,383   | Health state (CD4 200, asymptomatic   500, asymptomatic   symptomatic, pre-AIDS   AIDS (1993 definition)   AIDS (1987 definition)); medication payer; full vs. limited benefit paid<br>SA: Cost of ART +/- 20%; cost of all other medical care +/- 40%; insurance mix; eligibility expansion |

| First author, year    | Country | Aim and intervention(s)  | Modelling method; time horizon  | Perspective | Measure   | Result in 2011 USD  | Factors influencing input cost (including in sensitivity analysis, SA) <sup>6</sup>   |
|-----------------------|---------|--|---|-------------|---|---|---|
| Risebrough 1999 [42]  | Canada  | Incremental cost benefit of IDV+ZDV+3TC and ABC+ZDV+3TC over ZDV+3TC   | Markov; n.a.  | Society     | Cost per life year saved  | \$54,589 (IDV+ZDV+3TC), \$4,389 to \$27,516 (ABC+ZDV+3TC, depending on salvage regimen used)  | Regimen (HAART vs. salvage therapy), health state (200   AIDS);<br><br>SA: n.a.   |
| Caro 2001 [43]        | US      | Cost and effectiveness of EFV- or IDV-containing HAART regimens  | Monte Carlo simulation; 5 and 15 years                                      | Provider    | Daily cost of EFV and IDV; mortality rate and progression to AIDS after 5 years | \$14.71 (EFV), \$20.72 (IDV); 11% less mortality and 1,9% less progression to AIDS with EFV over IDV  | Regimen (two 1 <sup>st</sup> line, one 2 <sup>nd</sup> line, salvage therapy), health state ("responsive, tolerant and willing to adhere"   treatment failure   AIDS   final year);<br>SA: Treatment cost 10-200% (EFV-containing regimen), 50-300% (IDV-containing regimen)  |
| Schackman 2002 [44]   | US      | Full cost effectiveness of early initiation of HAART (i.e., at $\leq 350$ vs. $\leq 200$ CD4 cells/microl) in patients with low viral load   | Health state transition with Monte Carlo simulation (CEPAC model); lifetime | Provider    | Cost per QALY gained  | \$16,430 (early initiation without QoL adjustment for fat redistribution syndrome), \$21,485 to \$295,113 (with QoL adjustment for fat redistribution syndrome) | Regimen (1 <sup>st</sup> , 2 <sup>nd</sup> , 3 <sup>rd</sup> and 4 <sup>th</sup> line) and incidence of OIs and ADDs by health state (CD4 50   100   200   300   500);<br><br>no SA   |
| Schackman 2001 [45]   | US      | Incremental cost effectiveness and state budget impact of early (i.e., at CD4 $\leq 500$ cells/ $\mu$ l) and late (i.e., at CD4 $\leq 200$ cells/ $\mu$ l) initiation of HAART over no therapy | CEPAC model; lifetime(?)  | Society     | Cost per QALY gained  | \$22,839 (early), \$26,403 (late)   | One triple therapy regimen only; health state (CD4 50   100   200   300   500); acute OI episodes (not by health state); US state (MA/ NY/ FL/ national average);<br><br>SA: Additional 3 <sup>rd</sup> and 4 <sup>th</sup> line; drug prices +/- 50%   |
| Yazdanpanah 2002 [46] | France  | Lifetime cost and cost by clinical stage   | CEPAC model; lifetime   | Society     | Lifetime cost; cost per pt month  | Lifetime cost \$310,345; cost per pt month from \$739 (CD4>500) to \$11,090 (final month before death)  | Regimen (1 <sup>st</sup> , 2 <sup>nd</sup> , 3 <sup>rd</sup> , and 4 <sup>th</sup> line) and health state (no history of or current AIDS, by CD4 cell count   current AIDS   history of ADD but currently no AIDS   final month of life);<br>SA: Dosage of ARV drugs (+/-25% and +/-50%), duration of outpatient medication usage (50%, 75%, 90%), four consecutive lines of very efficacious/ low efficacy ART |
| Freedberg 2001 [47]   | US      | Incremental cost effectiveness of HAART using data from 4 different cohorts (ACTG, JH, INCAS, Dupont)  | CEPAC model; lifetime(?)  | Provider    | Cost per QALY gained  | \$32,076 (ACTG), \$23,708 (JH), \$18,129 (INCAS and Dupont)   | Regimen (1 <sup>st</sup> / 2 <sup>nd</sup> line) and health state (CD4 50   100   200   300   500 and VL 500   3000   10,000   30,000 cop/ml);<br>SA: Drug prices +/- 50%; OI treatment and routine care cost +/- 50%   |

| First author, year | Country | Aim and intervention(s)   | Modelling method; time horizon                                | Perspective | Measure                                   | Result in 2011 USD  | Factors influencing input cost (including in sensitivity analysis, SA) <sup>6</sup>  |
|--------------------|---------|---|---|-------------|---|---|--|
| Mauskopf 2000 [48] | US      | Incremental cost to medical system of treating 100 pts under the AIDS Drug Assistance Program (ADAP)                            | Static deterministic health state model; lifetime             | Provider(?) | Incremental cost                          | Incremental ADAP cost for HAART to 100 pts.: \$924,383<br>Decrease in total medical care cost, including drugs, for 100 pts.: \$9,914 | Health state (CD4 100   200   350   500);<br>SA: Drug cost +/- 10%; OI event cost +10% and +/- 25%   |
| Moore 1996 [49]    | US      | Incremental cost effectiveness of 3TC+IDV+ZDV over ZDV alone  | Health state transition; n.a.                                 | Provider    | Cost per life year saved                  | \$16,201 to \$29,162 (depending on the increase in other healthcare cost)   | Regimen; health state (CD4 200   500   AIDS);<br>no SA   |
| Simpson 2004 [50]  | US      | Incremental cost effectiveness of LPV/r+d4T+3TC over NFV+d4T+3TC as first line regimen  | Markov model; run until 50% of pts had died                   | Provider    | Cost per life year saved/ per QALY gained | \$8,058/ \$8,408 (not taking resistance development into account), cost savings (taking resistance into account)                      | Regimen, health state (CD4 50   200   350   500 and VL 400   20,000   100,000 cop/ml) and ) and incidence of OIs and ADDs by health state;<br>SA: Cost of OI events by 50-200%; cost of LPV/r                      |
| Munakata 2003 [51] | Canada  | Incremental cost effectiveness of adding enfuvirtide to an (unspecified) ART background regimen for treatment-experienced pts   | Markov model; n.a.  | Provider    | Cost per life year saved/ per QALY gained | \$178,915/<br>\$248,189   | Regimen; no other information available;<br>no SA  |
| Snedecor 2005 [52] | US      | Incremental cost effectiveness of HAART over non-HAART and of unspecified 'rescue regimen with 10% greater efficacy' over HAART | Monte Carlo Markov model; n.a.                                | Provider    | Cost per QALY gained                      | HAART: \$27,164<br>rescue regimen: \$16,029   | Regimen (two 1 <sup>st</sup> line regimens, one rescue regimen) and health state (CD4 categories n.a.);<br>no SA   |
| Sax 2005 [53]      | US      | Incremental cost effectiveness of a 4-drug regimen (2 PI+2 NRTI) plus enfuvirtide (ENF) over 4-drug regimen alone               | Health state transition with Monte Carlo simulation; lifetime | Provider    | Cost per QALY gained                      | \$89,229 (if ENF is administered only until VL returns to pre-treatment level);<br>\$215,947 (if ENF is given until death)            | Regimen and health state (CD4 50   100   200   300   500 and VL 500   3000   10,000   30,000   100,000 cop/ml); ENF given until VL returns to baseline;<br>SA: ENF cost (50-200%), continuation of ENF until death |

| First author, year | Country       | Aim and intervention(s)   | Modelling method; time horizon                                   | Perspective   | Measure   | Result in 2011 USD   | Factors influencing input cost (including in sensitivity analysis, SA) <sup>6</sup>   |
|--------------------|---------------|---|--|---|---|--|---|
| Long 2006 [54]     | Russia        | Effectiveness and cost-effectiveness of providing HAART to HIV+ IDUs and non-IDUs in Russia, comparing providing HAART only to IDUs (IDU-targeted strategy), only to non-IDUs (non-IDU targeted strategy), or to all HIV+ patients regardless of IDU status (untargeted strategy) | Dynamic compartmental model; 20 years                            | n.s.  | Cost per QALY gained over next best strategy, infections averted<br><br>20 yr time horizon  | <i>IDU targeted strategy</i> : incremental cost effectiveness over non-IDU targeted programme \$1,682 per QALY gained<br><br><i>Non-IDU targeted strategy</i> : incremental cost effectiveness over current program \$2,883 per QALY gained<br><br><i>Untargeted strategy</i> : incremental cost effectiveness over IDU targeted strategy \$2,104 per QALY gained<br><br><i>Optimistic untargeted strategy</i> : incremental cost effectiveness over untargeted strategy \$2,048 per QALY gained | Constant cost;<br><br>SA: Variation on ART and counselling cost   |
| Goldie 2006 [55]   | Cote d'Ivoire | Incremental cost effectiveness of 22 different starting and treatment options in ARNS trial cohort  | Health state transition with Monte Carlo simulation; lifetime(?) | Modified societal (patients' time and travel cost excluded) | Incremental cost per life year gained for a) cotrimoxazole prophylaxis, b) for ART and cotrimoxazole without CD4 testing, c) for ART and cotrimoxazole with CD4 testing | a) US\$ 295,<br>b) US\$ 761,<br>c) US\$ 1,449  | Only 1 <sup>st</sup> line in main analysis (2 <sup>nd</sup> line in SA); health state (CD4 200   terminal care); OI incidence dependent on CD4 and history of previous OI;<br><br>SA: Additional 2 <sup>nd</sup> line |
| Paton 2006 [56]    | Singapore     | Cost and cost-effectiveness of ART for HIV based on CDC stage of HIV infection (1. dual ART and 2. HAART)   | n.a.; 5 years  | Provider  | Incremental cost per life year gained   | <i>CDC stage A</i> :<br>1. \$11,247; 2. \$14,886<br><i>CDC stage B</i> :<br>1. \$7,187; 2. \$13,949<br><i>CDC stage C</i> :<br>1. \$6,512; 2. \$10,920   |   |

| First author, year | Country      | Aim and intervention(s)   | Modelling method; time horizon   | Perspective | Measure   | Result in 2011 USD   | Factors influencing input cost (including in sensitivity analysis, SA) <sup>6</sup>  |
|--------------------|--------------|---|--|-------------|---|--|--|
| Cleary 2006 [57]   | South Africa | Cost and incremental cost-effectiveness of ART over no ART treatment  | Markov model; lifetime   | Provider    | Total (incremental) cost per patient year/ per QALY gained<br><br>a) ART compared to No ART<br><br>b) Initiating ART when CD4<50 compared to starting when CD4 50-199 | Cost per patient year:<br>a) \$14,901 and \$13,203<br>b) \$15,018 and \$14,781<br><br>Cost per QALY gained:<br>a) \$18,280 and \$18,851<br>b) n/a<br><br>Incremental cost per QALY gained:<br>a) \$18,106<br>b) \$12,722   | Regimen (1 <sup>st</sup> line, 2 <sup>nd</sup> line) and, for the first 6 months on ART, health state (CD4 50   200), time on ART (3-monthly until 6 months on ART, 6-monthly until 36 months), inpatient cost by type of hospital (secondary vs. tertiary);<br><br>SA: 95% confidence intervals for all results (probabilistic SA)  |
| Over 2007 [58]     | Thailand     | Cost effectiveness of Thailand's National Access to Antiretroviral Program for People Living with HIV/AIDS (NAPHA) programme  | Deterministic difference-equation model with conditional demand allocation for different treatment modes; 20 years | Provider    | Cost per life year saved  | <i>First-line drugs only:</i><br>\$868 per LY saved<br><br><i>First- and second-line drugs:</i><br>- currently: \$2,540 per LY saved<br>- after issuing compulsory licenses (leading to a 90% reduction in the future cost of second-line drugs): \$1,108 per LY saved | All cost (including inpatient and outpatient service cost, not only drug cost!) by regimen (drug costs as weighted averages of six 1 <sup>st</sup> line regimens and two 2 <sup>nd</sup> line regimens, resp.); health state (asymptomatic   symptomatic), and mode of service delivery (public vs. augmented public vs. private)<br><br>Other scenarios considered: Compulsory licensing for 2 <sup>nd</sup> line drugs |
| Walensky 2010 [59] | South Africa | Incremental cost effectiveness of implementing elements of the 2010 WHO guidelines:<br>1. Routine CD4 monitoring<br>2. d4T- vs. TDF-based first line<br>3. Initiation by WHO stage vs. at <200 CD4 cells/microl vs. at <350 CD4 cells/microl<br>4. First-line only vs. first- and second-line ART | CEPAC-International model; lifetime(?)   | n.a.        | Cost per life year saved  | Three "economically efficient" combinations:<br>- <i>Stavudine/ &lt;350/ml/ one line:</i> \$614/ YL saved<br>- <i>Tenofovir/ &lt;350/ml/ one line:</i> \$1,197/ YL saved<br>- <i>Tenofovir/ &lt;350/ml/ two lines:</i> \$2,489/ YL saved                               | Regimen (two 1 <sup>st</sup> line, one 2 <sup>nd</sup> line), health state (CD4 50   100   200   300   500 and VL 500   3000   10,000   30,000 cop/ml);<br><br>SA: Cost of TDF, 2 <sup>nd</sup> line and CD4 cell count tests  |

| First author, year   | Country      | Aim and intervention(s)  | Modelling method; time horizon          | Perspective       | Measure   | Result in 2011 USD   | Factors influencing input cost (including in sensitivity analysis, SA) <sup>6</sup>   |
|----------------------|--------------|--|---|-------------------|---|--|---|
| Bendavid 2011 [60]   | South Africa | Incremental cost-effectiveness of different first-line regimens:<br>1. TDF/3TC/NVP<br>2. TDF/3TC/EFV<br>3. AZT/3TC/NVP<br>4. AZT/3TC/EFV<br>5. d4T/3TC/NVP | Simulation model; lifetime              | Societal          | Cost per QALY gained                                      | 1. Base<br>2. Dominated<br>3. \$1,098 per QALY gained<br>4. Dominated<br>5. \$6,250 per QALY gained  | Regimen (five 1 <sup>st</sup> line , one 2 <sup>nd</sup> line), health state (200   350)<br><br>SA: probabilistic   |
| Ciaranello 2011 [61] | South Africa | Incremental cost effectiveness of<br>1. no ART<br>2. LPV/r-based ART<br>3. NVP-based ART<br>in women after sdNVP exposure for PMTCT                        | CEPAC-International model; lifetime(?)  | Modified societal | Life years saved, cost and ICERs                          | 1. 1.6 yrs; \$3,130<br>2. \$851/LY saved (vs. 1)<br>3. \$1,597/LY saved (vs. 2)  | Regimen (4 regimens and "3 <sup>rd</sup> line maintenance" regimen) and health state (200   terminal care)<br><br>SA: Frequency of VL monitoring, additional 3 <sup>rd</sup> line regimen |
| Bachmann 2006 [62]   | South Africa | Incremental cost effectiveness of early (CD4<350) and late (CD4<200) prevention of progression of HIV/AIDS with ART or antibiotics                         | Markov Monte Carlo simulation; 10 years | Provider          | Cost per QALY gained                                      | Early intervention:<br>ART only \$3,345<br>ART+ antibiotics \$15,324<br>Antibiotics \$295<br><br>Late intervention:<br>ART only \$2,983<br>ART+ antibiotics \$3,024<br>Antibiotics only \$21 | Time on treatment (first 3 months vs. thereafter) and health state (tuberculosis   other infection   no infection, at below or above CD4 200);<br><br>no SA                               |
| Long 2010 [63]       | US           | Incremental cost effectiveness of expanded HIV testing and ART   | Dynamic model; 20 years                 | Societal          | Cost per QALY gained<br><br>20 yr horizon; lifetime costs | One-time screening: \$22,649 per QALY gained<br><br>Expanding ART coverage to 75% of eligible persons: \$20,542 per QALY gained<br><br>Combination strategy: \$21,840 per QALY gained        | One regimen cost only; health state (untreated asymptomatic   untreated symptomatic   treated symptomatic   untreated AIDS   treated AIDS)<br><br>SA: Cost not included                   |



| First author, year       | Country      | Aim and intervention(s)  | Modelling method; time horizon   | Perspective | Measure  | Result in 2011 USD   | Factors influencing input cost (including in sensitivity analysis, SA) <sup>6</sup>   |
|--------------------------|--------------|--|--|-------------|--|--|---|
| Over 2004 [64]           | India        | Cost-effectiveness of national ART programme 2003 to 2033<br>- for 40% of eligible pts falling under the poverty line ("Below the Poverty Line")<br>- for 25% of mothers and 1.5% of fathers of children eligible for PMTCT ("MTCT+")<br>- capacity building and subsidies for laboratory tests, with antiretroviral treatment paid for by patients ("ADHERE") | Epidemiological model; lifetime(?)                                       | Provider    | Cost per life year saved   | Below the Poverty Line:<br>- no change in condom uptake: \$378 per LY saved<br>- 70% condom use rate: \$69 per LY saved<br>- 90% condom use rate: \$40 per LY saved<br><br>MTCT+:<br>- no change in condom uptake: \$268 per LY saved<br><br>ADHERE:<br>- no change in condom uptake: \$197 per LY saved   | Time on treatment (first 3 years vs. year before death); health state (symptomatic, non-AIDS   AIDS); unstructured vs. structured treatment provision<br><br>SA: Cost not included  |
| Vijayaraghavan 2006 [65] | South Africa | Incremental cost effectiveness of implementing DHHS treatment guidelines (initiate treatment at CD4<350 or viral load>100,000 and monitor with CD4 counts and viral load every three months) over WHO guidelines (initiate treatment at CD4<200 or for patients with AIDS and monitor using CD4 counts every 6 months)   | Markov model with Monte Carlo simulation; lifetime                       | Societal    | Incremental cost per QALY gained<br>a) not including impact on transmission<br>b) including impact on transmission<br>c) including indirect costs (without transmission) | a) \$5,865 per QALY gained<br>b) \$4,594 per QALY gained<br>c) \$1,550 per QALY gained<br><br>'Over a five-year period, treating all HIV patients in South Africa according to US DHHS versus WHO guidelines would increase direct medical costs by US\$14.5 billion but would result in approximately 400,000 fewer deaths and 1.1 million fewer new AIDS cases.' | Regimen (1st line, 2nd line) and health state (if not on ART: CD4 350   200 and asymptomatic   symptomatic   AIDS; if on ART, additionally: unsuppressed   toxicity   suppressed   without additional treatment options)<br><br>SA: Cost of VL and of 2nd line +/- 25%,<br><br>Regimen (1st line, 2nd line);<br>no SA |
| Granich 2009 [28]        | South Africa | Impact of universal voluntary testing and immediate treatment (UTT) on annual cost, HIV incidence and prevalence   | Deterministic transmission model and stochastic survival model; 43 years | Provider(?) | Impact on incidence, prevalence, and overall programme cost  | Incidence: reduction to <1/1000 per year by 2016 (within 10 yrs of full implementation of UTT)<br><br>Prevalence: reduction to less than 1% within 50 years<br><br>Cost: same as base case until 2032 (US\$1.7 billion); lower thereafter  | Regimen (1st line, 2nd line);<br>no SA  |
| Hontelez 2011 [29]       | South Africa | Incremental cost benefit of ART initiation at different CD4 cell count thresholds (<200 vs. <350)  | Simulation model; 30 years   | Provider    | Total cost of ART programme  | Initiation at <350 costs 7% more per annum during first 5 years, with cost decreases due to reduction in incidence and ART need after 7 years; break-even in cost after on average 16 years  | Regimen (1st line, 2nd line), baseline (not current) CD4 cell count (100   200   350) for first three years;<br><br>SA: Cost varied by +/- 33%  |

3TC: lamivudine; ABC: abacavir; AZT: zidovudine; d4T: stavudine; ChoICE: WHO's "CHOosing Interventions that are Cost-Effective" Team; DALY: disability-adjusted life-year; ddC: zalcitabine; EFV: efavirenz; GFATM: Global Fund to fight AIDS, Tuberculosis and Malaria, HAART: highly-active antiretroviral therapy; ICER: incremental cost-effectiveness ratio; IDV: indinavir; LPV/r: lopinavir/ ritonavir; LY: life years; n.a.: not available; NRTI: nucleoside reverse transcriptase inhibitor; NVP: nevirapine; PMTCT: prevention of mother-to-child transmission; pt: patient; pts: patients; QALY: quality-adjusted life-year; QoL: quality of life; SA: sensitivity analysis; TDF: tenofovir; USD: US dollar; VL: viral load; WHO: World Health Organization; yr: year; ZDV: zidovudine

**Table 7: Regional economic analyses**

| First author, year     | Region                                 | Aim and method   | Modelling method; time horizon     | Perspective | Measure   | Result in 2011 USD   | Factors influencing input cost (including in sensitivity analysis, SA)   |
|------------------------|--|--|------------------------------------|-------------|---|--|--|
| Bonnef 2000 [66]       | Sub-Saharan Africa                     | Cost of scaling up ART by 10% in countries with very low and low current HIV programme strength, and by 25% in countries with a medium or strong current HIV programme | n.a., 5 years                      | Provider    | Cost per patient year                                     | \$2,993 - \$5,208  | Regimen (drug costs set at 73%-86% of current US drug prices);   |
|                        |  |  |                                    |             | Total annual cost   | \$2.3 - 3.6 billion  | no SA  |
| Kumaranayake 2001 [67] | Sub-Saharan Africa                     | Incremental cost of ART provision (target coverage of 48% in 2007 and 62% in 2015)   | n.a.; 8 years                      | Provider    | Total annual cost   | \$4.0 to 6.5 billion (2007); \$5.8 to 9.3 billion (2015)   | No details available, but cost likely to be constant;<br><br>no SA   |
| Creese 2002 [68]       | Sub-Saharan Africa                     | Incremental cost-effectiveness of ART based on previously published estimates  | Systematic review ; n.a.           | Provider    | Cost per life year gained                                 | \$1,582 -2,608   | Constant cost;<br><br>no SA  |
| Hogan 2005 [69]        | Sub-Saharan Africa and South East Asia | Cost effectiveness of ART provided through antenatal care clinics  | Epidemiological model; lifetime(?) | n.a.        | 1) Cost per infection averted<br>2) Cost per DALY averted | <i>No intensive monitoring, 1<sup>st</sup> line drugs:</i><br>1) \$42,109 2) \$835<br><i>Intensive monitoring, 1<sup>st</sup> line drugs:</i><br>1) \$52,302 2) \$895<br><i>No intensive monitoring, 2<sup>nd</sup> line drugs:</i><br>1) 271,985 2) \$3,019<br><i>Intensive monitoring, 2<sup>nd</sup> line drugs:</i><br>1) \$278,436 2) \$2,969 | Regimen (1 <sup>st</sup> line, 2 <sup>nd</sup> line), type of monitoring;<br><br>SA: Variation of programme cost in relation to patient cost |

3TC: lamivudine; ABC: abacavir; AZT: zidovudine; d4T: stavudine; CHOICE: WHO's "CHOosing Interventions that are Cost-Effective" Team; DALY: disability-adjusted life-year; ddC: zalcitabine; EFV: efavirenz; GFATM: Global Fund to fight AIDS, Tuberculosis and Malaria, HAART: highly-active antiretroviral therapy; ICER: incremental cost-effectiveness ratio; IDV: indinavir; LPV/r: lopinavir/ ritonavir; LY: life years; n.a.: not available; NRTI: nucleoside reverse transcriptase inhibitor; NVP: nevirapine; PMTCT: prevention of mother-to-child transmission; pt: patient; pts: patients; QALY: quality-adjusted life-year; QoL: quality of life; SA: sensitivity analysis; TDF: tenofovir; USD: US dollar; VL: viral load; WHO: World Health Organization; yr: year; ZDV: zidovudine

**Table 8: Global economic analyses**

| First author, year      | Countries/ Regions                   | Aim and method   | Modelling method; time horizon  | Perspective | Measure  | Result in 2011 USD   | Factors influencing input cost (including in sensitivity analysis, SA)   |
|-------------------------|--------------------------------------|--|---|-------------|--|--|--|
| Floyd 1997 [70]         | Worldwide                            | Cost of global ART provision (100% coverage)                             | Estimation based on population and prevalence data; n.s.                                    | Provider    | Cost per patient year<br><br>Total annual cost         | - AZT monotherapy: \$6,252 to \$8,269<br>- triple ART (excluding ritonavir): \$15,368 to \$24,344<br><br>-Triple ART: \$133.3 - \$176 billion globally (Sub-Saharan Africa: \$74.5 - \$98.4 billion, Southeast Asia \$41.7 - \$55 billion, Latin America \$6.6 - \$8.8 billion, North America \$5.9 - \$7.9 billion, Western Europe \$4.5 - \$5.9 billion) | Constant cost data using drug prices from US, laboratory and hospital cost data from US, Uganda, South Africa and Malawi, resource use modelled on UK guidelines;<br><br>no SA |
| Hogg 1998 [71]          | Worldwide                            | Cost of global ART provision (25% coverage)                              | Estimation based on population and prevalence data and coverage in British Columbia; 1 year | Provider    | Total annual cost                                      | \$110 billion globally (95% CI 35 - 189 billion (Sub-Saharan Africa \$75 billion, South and South East Asia \$22 billion, Americas \$8 billion, Western Europe \$1.7 million)  | Constant drug cost using data from the US;<br><br>SA: Drug cost reduced by 50, 75, 90 and 99%; additional probabilistic analysis   |
| Attaran 2001 [72]       | Worldwide                            | Cost of global ART and prevention  | Estimation based on prevalence data and assumed cost of ART; 3 years                        | Provider    | Total annual cost                                      | \$10.8 billion   | Constant assumed cost of ART and palliative care \$500, and of prevention \$10 per pt yr;<br><br>no SA   |
| Schwartländer 2001 [73] | 135 low- and middle-income countries | Cost of global ARV drugs and laboratory monitoring for eligible patients | Model based on UNAIDS estimates of population in need, access to care assumptions, 5 years  | Provider    | Cost per patient year in 2005<br><br>Total annual cost | \$826-5,467<br><br>\$3.8 billion (27% of total resource need for treatment and prevention)   | Per-capita Gross National Product (differential pricing for drugs), age (cost of care for children assumed to cost 50% of adult care);<br><br>no SA                            |

| First author, year      | Countries/ Regions  | Aim and method   | Modelling method; time horizon         | Perspective | Measure  | Result in 2011 USD  | Factors influencing input cost (including in sensitivity analysis, SA)   |
|-------------------------|---|--|--|-------------|--|---|--|
| Gutierrez 2004 [74]     | Worldwide   | Cost of 3 by 5 programme (ART to 3 million eligible patients by 2005)  | Health-state transition model; 2 years | Provider    | Total cost of programme  | \$6.4 - 7.4 billion   | Regimen (two 1 <sup>st</sup> line, one 2 <sup>nd</sup> line), current prices or prices negotiated by Clinton Foundation;<br><br>no SA  |
| Stover 2011 [75]        | 104 low- and middle income countries receiving support from GFATM | Cost of maintaining 3.5 million people currently supported (with 25% of total cost) by GFATM on ART in 2011-2020   | Spectrum model; 10 years               | Provider    | Annual cost of ART to 2011 GFATM cohort<br><br>Life-years saved per year | \$2 billion (2011), \$1.8 billion (2020)<br><br>830,000 (2011), 2.3 million (2015-2020)   | Regimen (1 <sup>st</sup> line, 2 <sup>nd</sup> line); end-of-life treatment separately<br><br>SA: Reduction in ARV drug prices per year: 5% in 1 <sup>st</sup> line, 11% in 2 <sup>nd</sup> line drugs; replacement of d4T by other drugs; migration to 2 <sup>nd</sup> line 6% per year   |
| Resch 2011 [76]         | 104 low- and middle income countries receiving support from GFATM | Cost benefit of maintaining 3.5 million people currently supported (with 25% of total cost) by GFATM on ART in 2011-2020   | Spectrum model; 10 years               | Societal    | Total programme cost<br><br>Total programme benefit                      | \$14.9 billion<br><br>\$13-\$36 billion (94% of which due to productivity gains)  | Cost based on Stover 2011; benefits:<br>- productivity gains (valued by per-capita income)<br>- orphanhood avoided (cost based on literature)<br>- end of life care postponed (literature)<br><br>SA: Productivity of treated/ untreated patients in relation to asymptomatic patients; valuation of productivity by friction cost only  |
| Schwartländer 2011 [77] | Worldwide   | Incremental cost effectiveness of "investment approach" to achieving universal access to HIV prevention, treatment, care and support (including interventions, social and programme 'enablers' and synergies with other development sectors) | Resource Needs Model; 9 years          | Provider    | Cost per LY saved  | Incremental cost-effectiveness ratio \$1,077 per life year saved<br>Cost: \$22 billion; 12.2 million HIV infections averted; 7.4 million deaths from AIDS averted; 29.4 million life-years gained; "additional investment proposed would be largely offset from savings in treatment costs alone" | Not much information given, but "average cost per patient of antiretroviral therapy is assumed to decline by about 65% between 2011 and 2020, with a large proportion of the cost savings after 2015 coming from an increasing shift to primary care and community-based approaches and cheaper point-of-care diagnostics";<br><br>no SA |

3TC: lamivudine; ABC: abacavir; AZT: zidovudine; d4T: stavudine; ChoICE: WHO's "CHOosing Interventions that are Cost-Effective" Team; DALY: disability-adjusted life-year; ddC: zalcitabine; EFV: efavirenz; GFATM: Global Fund to fight AIDS, Tuberculosis and Malaria, HAART: highly-active antiretroviral therapy; ICER: incremental cost-effectiveness ratio; IDV: indinavir; LPV/r: lopinavir/ ritonavir; LY: life years; n.a.: not available; NRTI: nucleoside reverse transcriptase inhibitor; NVP: nevirapine; PMTCT: prevention of mother-to-child transmission; pt: patient; pts: patients; QALY: quality-adjusted life-year; QoL: quality of life; SA: sensitivity analysis; TDF: tenofovir; USD: US dollar; VL: viral load; WHO: World Health Organization; yr: year; ZDV: zidovudine

## 5 Outpatient and inpatient cost of adult ART in urban and semi-urban South Africa

### Cost and Resource Use of Patients on Antiretroviral Therapy in the Urban and Semiurban Public Sectors of South Africa

1. For a 'research paper' already published
  - 1.1. Where was the work published? **JAIDS**
  - 1.2. When was the work published? **2012**
  - 1.3. Was the work subject to academic peer review? **Yes**
  - 1.4. Have you retained the copyright for the work? **No**

If yes, attach evidence of retention

If no, or if the work is being included in its published format, attach evidence of permission from copyright holder (publisher or other author) to include work **See exemption on next page**

2. For a 'research paper' prepared for publication but not yet published
  - 2.1. Where is the work intended to be published?
  - 2.2. List the paper's authors in the intended authorship order
  - 2.3. Stage of publication – Not yet submitted/Submitted/Undergoing revision from peer reviewers' comments/In press
3. For multi-authored work, give full details of your role in the research included in the paper and in the preparation of the paper. (Attach a further sheet if necessary)

**The candidate collected all data, did all the data analysis and wrote the publication.**

Candidate's signature



Dr Gesine Meyer-Rath

Supervisor or senior author's signature to confirm role as stated in (3)



Dr Alec Miners

Supervisor

Wolters Kluwer  
Health

Lippincott Williams &amp; Wilkins

Requesting permission to  
reuse content from an  
LWW publication.

Title: Cost and Resource  
Use of Patients on  
Antiretroviral  
Therapy in the Urban  
and Semiurban Public  
Sectors of South  
Africa

Author: Gesine Meyer-Rath,  
Alec Miners, Andreia  
Santos, et al

Publication: JAIDS: Journal of  
Acquired Immune  
Deficiency Syndrome

Publisher: Wolters Kluwer  
Health, Inc.

Date: Jan 1, 2012

Copyright © 2012, (C) 2012  
Lippincott Williams

This reuse is free of charge. No permission letter is needed from Wolters Kluwer Health, Lippincott Williams & Wilkins. We require that all authors always include a full acknowledgement. Example: AIDS: 13 November 2013 - Volume 27 - Issue 17 - p 2679-2689. Wolters Kluwer Health Lippincott Williams & Wilkins© No modifications will be permitted.

Copyright © 2015 [Copyright Clearance Center, Inc.](#) All Rights Reserved.  
[Privacy statement.](#) [Terms and Conditions.](#)

Comments? We would like to hear from you. E-mail us at  
[customercare@copyright.com](mailto:customercare@copyright.com)

## ***Preamble for paper 1***

Given the scarcity of relevant cost analyses of public-sector ART provision in South Africa at the start of my work on the model, as described in chapter 4, the National ART Cost Model draws on a number of inputs from other analyses. This paper gives the details of a bottom-up analysis of the cost of ART provision to adults in the urban and semi-urban public sector in South Africa. Data for this analysis was collected in 2006-2008, i.e., three to five years into the public-sector roll-out of ART, in two typical stand-alone specialised ART clinics. While the urban clinic was part of the outpatient department of a tertiary hospital in central Johannesburg, the semi-urban clinic was set in a township in the predominantly rural North West province; the paper therefore represents two common models of care in the early years of the ART roll-out.

Paper 1 is one of the few papers of the cost of ART in South Africa that includes outpatient and inpatient cost for the same cohort; and it is the only such paper that compares the cost of two cohorts in different geographic locations using identical methods. Note that only the outpatient costs (which were almost identical between the settings, although with a vastly different distribution across different cost items such as staff and other fixed costs, and laboratory costs) were included as inputs for the NACM, and that the ARV drug costs in the paper had been adjusted to represent the 2011 drug tender prices which were used only in the “Reference List” sub-scenario in the NACM.

The analytical framework for the calculation of fixed cost used in this analysis was developed by Sydney Rosen and Lawrence Long. All co-authors contributed comments and edited the paper. All other work, including study design, data collection, data analysis, and writing the first and consecutive drafts of the paper, was the candidate's.



## **Paper 1**

### **Cost and resource use of patients on antiretroviral therapy in the urban and semi-urban public sectors of South Africa**

Gesine Meyer-Rath, MD<sup>1,2,3†</sup>, Alec Miners, PhD<sup>1</sup>, Andreia C. Santos, PhD<sup>1</sup>, Ebrahim Variava, MD<sup>4</sup>, Willem Daniel Francois Venter, MD<sup>5</sup>

<sup>1</sup> Department of Health Services Research and Policy, London School of Hygiene and Tropical Medicine, UK

<sup>2</sup> Health Economics and Epidemiology Research Office (HE<sup>2</sup>RO), Department of Internal Medicine, School of Clinical Medicine, Faculty of Health Sciences, University of the Witwatersrand, South Africa

<sup>3</sup> Center for Global Health and Development, Boston University, US

<sup>4</sup> Tshepong-Klerksdorp Hospital Complex, Klerksdorp, South Africa

<sup>5</sup> Wits Institute for Reproductive Health and HIV, Faculty of Health Sciences, University of the Witwatersrand, South Africa

**† Corresponding author details:** Health Economics and Epidemiology Research Office, Themba Lethu Wing, Helen Joseph Hospital, Perth Road, Westdene, Johannesburg, 2092, South Africa. Phone: +27-76-528 1767; fax: +27-11-276 8885; email: [gesine@bu.edu](mailto:gesine@bu.edu)

**Conflicts of interest and sources of support:** GMR's work on this study was funded by a research agreement under the Operational Plan for Comprehensive HIV and AIDS Care, Management and Treatment of South Africa from the South African Department of Health and the South African Medical Research Council as well as a research agreement with the World Health Organization (obligation no. HQ/06/052223). WDFV is supported by PEPFAR. For the remaining authors no conflicts of interest were declared.

#### **ABSTRACT**

**Background:** South Africa has the world's largest number of patients on antiretroviral treatment (ART). As coverage expands beyond urban environments, the cost of care is becoming increasingly important.

**Methods:** Health care cost data for the first year after initiation were analysed for cohorts of patients in a semi-urban and an urban public-sector ART clinic in South Africa. We compared mean cost by CD4 cell count and time on ART between clinics.

**Results:** Patients in both clinics had comparable CD4 cell counts at initiation and under treatment. In the urban clinic, mean cost per patient year on ART in 2011 USD was \$1,040 (95% confidence interval, CI, \$800-\$1,280), of which outpatient cost was \$692 (67%) and inpatient cost \$348 (33%). 14% of urban patients required inpatient care at a mean length of stay (LOS) of 9 days and mean cost per hospitalised patient of \$1,663 (95% CI \$1,103-\$2,041). In the semi-urban clinic, mean cost per

patient year on ART was \$1,115 (95% CI \$776-\$1,453), of which outpatient cost was \$697 (63%) and inpatient cost \$418 (37%). 7% of semi-urban patients required inpatient care at a mean LOS of 28 days and mean cost per hospitalised patient of \$3,824 (95% CI \$1,143-\$6,505).

**Conclusions:** Outpatient ART provision in the semi-urban setting cost the same as in the urban setting, but inpatient costs are higher in the semi-urban clinic due to longer hospitalisations. Cost in both clinics was highest in the first 3 months on ART and at CD4 cell counts < 50 cells/microl.

**Keywords:** HIV, economics, middle-income, antiretroviral treatment, cost analysis, rural

## INTRODUCTION

South Africa is home to both the largest number of people infected with HIV and people on antiretroviral treatment (ART) worldwide<sup>1</sup>. In order to plan for a programme that currently covers more than 1.5 million patients, or 20% of the world's population on ART in low- and middle-income countries<sup>1,2</sup>, information on the cost of ART provision is needed. Since 2004, a number of studies have been undertaken which have resulted in cost estimates of ART provision for a variety of different settings and models of care in South Africa<sup>3-7</sup>. These studies almost exclusively focus on large clinics in urban settings, while recent policy changes have led to a re-focussing of the national ART programme on increasing coverage of currently underserved semi-urban and rural communities. In order to reach the target of 80% ART coverage of the eligible population by the end of financial year 2010/11 set by the 2007 National Strategic Plan<sup>8</sup>, the 2010 National ART Guidelines introduced nurse-initiation and management of ART (NIMART)<sup>9</sup>. Involving the nurse cadre, together with strengthened political leadership, has led to a rapid increase in the number of clinics accredited for ART provision from 497 in January 2010 to 1,668 by January 2011<sup>10</sup>. Most of the additional clinics are primary healthcare clinics (PHC) outside large urban centres. To help with planning and budgeting to sustain this effort, information on the cost of ART provision in more remote settings is urgently needed.

This study compares resource utilisation and the cost of providing antiretroviral treatment to large numbers of patients in two different settings in the South African public sector: an urban clinic in central Johannesburg and a semi-urban, township-based clinic in the North West province, using identical methods. In order to correct for differences in case mix and disease severity, the development of per-patient costs are then compared to patients' CD4 cell count development over time.

## METHODS

### Study setting

Data on the cost of ART provision was collected in two South African cohorts of patients initiating ART at a clinic attached to Charlotte Maxeke Johannesburg Academic Hospital (CMH), an urban tertiary academic hospital in the inner city of Johannesburg, Gauteng, between April 2006 and August 2008 (n=181), and at a clinic attached to Tshepong Hospital (TWC), a secondary hospital in the township of Jouberton close to Klerksdorp, North West Province, between January 2007 and December 2008 (n=184). Both clinics started providing routine ART care as part of the national antiretroviral treatment roll-out in the public sector commencing in 2004. While TWC is situated in a densely populated area with formal and informal semi-urban housing, it is further removed from central urban infrastructure than CMH.

### **Patient cohorts**

A consecutive sample of patients was enrolled into the study during the period of treatment preparation, before ART initiation. Patients' consent was obtained for three-monthly interviews and review of their clinical information.

In order to enter each clinic, patients had to fulfil eligibility criteria as detailed in the 2004 national antiretroviral treatment guidelines: they had to have tested HIV-positive and have at least one recorded CD4 cell count of <200 cells/microl and/ or WHO stage 4 HIV disease<sup>11</sup>. Before treatment initiation, patients underwent a series of preparatory visits including medical examination, laboratory and other diagnostic tests as indicated, and up to three individual or group counselling sessions with an adherence counsellor. Only those patients initiated on ART during their participation in the study were included in the analysis.

### **Cost and resource use included**

We collected information on the economic costs incurred for each patient in a cohort of patients initiated on ART in each of the two clinics from the healthcare provider perspective, using a microcosting approach to resource use and costs at the outpatient and hospital level<sup>12</sup>. We included all healthcare resources used by patients from up to three months before ART initiation until either 12 months after ART initiation or, in case of patients dying, defaulting from care, or being down-referred to another clinic during the first year on ART, until the last visit to the clinic. Down-referral is a process by which patients who are stable on therapy and have achieved an undetectable viral load get referred to a clinic at primary health-care level closer to their home. The cost analysis includes the cost of drugs (antiretroviral and non-antiretroviral drugs), of diagnostic and monitoring tests (including laboratory tests and radiological examinations), labour cost, and overheads, staff training in HIV management, infrastructure and medical equipment and furniture.

### **Data sources**

#### ***Outpatient cost***

##### *Resource use*

Data on patients' resource use was obtained via a retrospective review of the clinic files of study patients. The number of laboratory tests was confirmed by a review of the patient records of the

public-sector National Health Laboratory Service at each hospital; the number of radiological examinations by a review of the electronic database of the radiology department where available. With regards to non-ARV costs, we made a number of assumptions and exclusions. All patients with CD4 cell counts below 200 cells/microl were assumed to be prescribed cotrimoxazole for the prevention of opportunistic infections. Every patient was assumed to have been prescribed multivitamins throughout their stay in the clinic. We excluded all tuberculosis treatment costs since, although the first dose of such treatment might be prescribed at the ART clinic, TB is managed entirely off-site at primary health-care clinics. In order to focus the analysis on the cost of antiretroviral treatment provision alone, we excluded this resource use.

#### *Unit costs*

Data on unit costs came from government drug depots (medication), the public-sector National Health Laboratory Service (laboratory costs), the hospitals' radiology departments (x-ray examinations and ultrasound), clinic management (staff numbers and levels, numbers of patients and visits per year) and the finance, human resources, asset and store departments of both hospitals involved (staff salaries, equipment, supplies, overheads). Data was collected in an electronic format where available and otherwise abstracted from print-outs and paper-based price lists.

All fixed cost data for one clinic was entered into an Excel spreadsheet to impute totals and calculate the average fixed cost per patient month, taking into account the number of patients in both ART and in pre-ART care in the clinic, the average number of visits for both of these patient subgroups by year, and the number of months spent in the clinic by each of the study patients. Space and utilities costs for the entire hospital were allocated by using the ratio of clinic-to-hospital space as calculated from hospital floor plans and measurements of the clinic space.

#### ***Inpatient cost***

##### *Resource use*

Patient files were reviewed for information on the dates of admission and discharge, discharge diagnoses and names of hospitals that patients were admitted to. To capture the cost of inpatient resource use under ART only, we excluded any hospitalisations that occurred before ART initiation. To complement the information available from the files, we asked patients during 3-monthly interviews after ART initiation about any hospital stays since the last interview and recorded length of stay, hospital, and diagnosis where available. If there was incongruence between interviews and files with regards to hospitalisation events, we deferred to the information from the interviews. We assumed that the length of stay of those hospitalisations with missing admission and/ or discharge dates was the same as the average length of stay of those patients with complete dates.

##### *Unit costs*

For the unit cost of inpatient days we used the cost per patient day equivalent (PDE) of the hospitals the patients were admitted to. This information is collected by the management of all public-sector

hospitals in South Africa which divides total hospital expenditure during a financial year by the total number of visits to the hospital. For the denominator, the number of visits to day wards or outpatient clinics is weighted by their average duration in relation to a full day of inpatient stay so that the result represents the average cost per inpatient day. Cost per PDE is calculated annually, allowing us to use the cost specific to the year that a patient was hospitalised in.

### ***CD4 cell count data***

In both clinics, patients' responsiveness to ART is measured by regular CD4 cell count measurements which are undertaken once before and every three to six months after treatment initiation. The clinic files of participants as well as the electronic laboratory database were reviewed for laboratory data on participants' CD4 cell counts for the duration of the study.

### **Data collection and analysis**

Data on resource use, clinical status and CD4 cell count was collected using paper templates from which data were entered into Excel spreadsheets, with 10% of the sample double-entered for quality control. Mistakes were found in 5% of the double-entered data and most often pertained to the dosages of non-antiretroviral drugs, a component that does not contribute much to total cost (see below).

Capital costs were annualised using the government depreciation rate of 10% for telephones, 20% for computers and other electronic equipment, 6.7% for other office equipment, and 1% for buildings<sup>13</sup>. For patients who were in care for less than a year due to defaulting, death or down-referral, mean total costs were annualised. Unit costs were taken from the year in which the corresponding resources were used (2006-2008) and were adjusted for inflation to 2011 USD, using the 2009 average conversion rate of 1 USD = 8.442 ZAR and the country's average Consumer Price Inflation Index <sup>14</sup>, with one exception: Since the prices of ARV drugs have halved on average since the data collection period, we used 2011 unit costs for ARV drugs rather than upward-adjust their cost for inflation. All costs are presented in 2011 USD.

For the comparison between cost and CD4 cell count by 3-month intervals since ART initiation, the results of CD4 cell count tests were attributed to the same 3-month time period since ART initiation as cost, depending on the date on which the test was undertaken. If CD4 cell counts were missing for one or two consecutive 3-month periods, their values were interpolated linearly from CD4 cell counts in the adjacent periods. Baseline CD4 cell counts were defined as the lowest CD4 cell count during the three months before ART initiation. We used two-sided t-tests and Wilcoxon sum rank tests to compare mean cohort CD4 cell count and mean and median cost in each 3-month period on ART, and mean and median cost associated with each CD4 cell count stratum, respectively, in between clinics. All statistical analysis was done in SAS version 9.1.

The study was approved by the Human Research Ethics Committee of the University of the Witwatersrand and the Ethics Committee of the London School of Hygiene and Tropical Medicine.

## RESULTS

### Patient status and length of follow-up

Cohort length of follow-up differed between the two settings, largely as the result of higher rates of down-referral at TWC during the second half of the study period. 28% of patients at TWC had been down-referred by month 9, and 39% by month 12, as opposed to 2% and 3% at CMH. This resulted in TWC contributing 1,878 patient months to the study, compared to 2,040 at CMH. Default and death rates were comparable in both clinics, with 1 patient (1%) having died and 16 patients (9%) having defaulted by 12 months at CMH, as compared to 4 (2%) and 11 patients (6%) at TWC, respectively.

### Development of CD4 cell count over time

In both clinics cohort CD4 cell counts increased steadily under ART (Table 1). Differences in mean CD4 cell count by all 3-month periods on treatment between the two clinics were not significant at the <0.05 level, except for month 1 to 3 after initiation where the average CD4 cell count at TWC was much lower, and for month 7 to 9 after initiation where it was higher.

**Table 1: Development of mean CD4 cell counts over time on ART, by clinic**

| Months on ART | Johannesburg (CMH) |   | Jouberton (TWC) |   | p for comparison between clinics (t-test) |
|---------------|--------------------|---|-----------------|---|---|
|               | n                  | Mean CD4 cell count (95% confidence interval) | n               | Mean CD4 cell count (95% confidence interval) |   |
| -3 - 0        | 178                | 99 (89-109)                                   | 182             | 97 (89-106)                                   | 0.8310                                    |
| 1 - 3         | 181                | 166 (153-180)                                 | 182             | 123 (110-136)                                 | <.0001                                    |
| 4 - 6         | 177                | 210 (193-228)                                 | 168             | 187 (166-207)                                 | 0.0826                                    |
| 7 - 9         | 158                | 239 (219-259)                                 | 143             | 297 (271-322)                                 | 0.0006                                    |
| 8 - 12        | 126                | 284 (260-309)                                 | 98              | 312 (277-351)                                 | 0.1720                                    |

### Cost and resource use

#### Outpatient cost and resource use

Table 2 summarises outpatient resource use and unit costs for both clinics.

**Table 2: Outpatient resource use and unit cost [2011 USD]**

| Resource use item <sup>7</sup> | Johannesburg (CMH)          |                        | Jouberton (TWC)             |                        |
|--------------------------------|-----------------------------|------------------------|-----------------------------|------------------------|
|                                | Patient months (% of total) | Cost per patient month | Patient months (% of total) | Cost per patient month |
| d4T + 3TC + EFV                | 2,066 (89)                  | 10                     | 1,589 (91)                  | 10                     |
| d4T + 3TC + NVP                | 77 (3)                      | 8                      | 25 (1)                      | 8                      |
| AZT + 3TC + EFV                | 188 (8)                     | 17                     | 124 (7)                     | 17                     |
| AZT + ddl + LPV/r              | -                           | 69                     | -                           | 69                     |

<sup>7</sup> This table gives the details of all cost items apart from non-antiretroviral drugs, which are too many to summarise.

| Diagnosics and monitoring | Number of tests in cohort   | Cost per test                                    | Number of tests in cohort  | Cost per test                                   |
|---------------------------|---|--|--|---|
| CD4 cell counts           | 468   | 10   | 296  | 10  |
| HIV viral loads (VL)      | 511   | 50   | 401  | 50  |
| Alanine transaminase      | 554   | 6  | 140  | 6   |
| Albumin                   | 308   | 5  | 31   | 5   |
| Aspartate transaminase    | 534   | 6  | 143  | 6   |
| TB culture (liquid)       | 37  | 4  | 98   | 4   |
| TB culture (R/M)          | 128   | 26   | 111  | 26  |
| Bilirubin                 | 291   | 3  | 33   | 3   |
| Creatinine                | 218   | 4  | 134  | 4   |
| Full blood count          | 469   | 7  | 198  | 7   |
| Hepatitis (per antigen)   | 151   | 16   | 41   | 16  |
| U+E                       | 211   | 10   | 128  | 10  |
| Alkaline phosphatase      | 293   | 5  | 32   | 5   |
| TB smear microscopy       | 149   | 5  | 106  | 5   |
| Radiology                 | Number of examinations in cohort  | Cost per examination                             | Number of examinations in cohort   | Cost per examination                            |
| Chest x-ray               | 261   | 19   | 136  | 12  |
| Abdominal ultrasound      | 71  | 87   | 3  | 36  |
| Electrocardiogram         | -   | -  | 2  | 18  |
| Mammogram                 | -   | -  | 1  | 12  |
| Fixed cost                |   |  |  |   |
| Staff                     | Number of staff in clinic (average <sup>8</sup> )   | Total annual salary cost for clinic (all staff)  | Number of staff in clinic  | Total annual salary cost for clinic (all staff) |
| Physicians                | 0.24 consultant, 2.75 registrars, 0.8 medical officer, 0.45 intern, 2 doctor advisors                         | 991,291 (2006); 841,792 (2007); 1,054,840 (2008) | 0.24 chief specialist, 2 principal medical officers, 1 medical officer, 1 community service doctor, 0.3 intern                     | 1,230,102 (2007); 1,224,148 (2008)              |
| Nurses                    | 6 clinical nurse practitioners, 1 senior enrolled nurse, 1 nurse  |  | 3 senior nurse practitioners, 2 senior nurse assistants, 2 clinical nurse practitioners, 1 senior staff nurse, 1 nursing assistant |   |
| Counsellors               | 5 lay counsellors   |  | 4 lay counsellors  |   |
| Administrative staff      | 0.75 manager, 1 project manager, 4 clerks   |  | 5 admin clerks grade 2, 1 data capturer, 1 admin officer   |   |
| Support staff             | 1 social worker, 3 pharmacists, 2 pharmacy clerks, 1 quality improvement manager, 1 quality improvement nurse |  | 2 senior pharmacists, 1 senior medical social worker, 1 senior dietician, 1 defaulter tracer, 1 quality assurance officer,         |   |

<sup>8</sup> In CMH, the number of staff changed between the years of data collection (2006-2008); the numbers given here are averaged over those years.

|                              | practitioner, 1<br>defaulter tracer, 2<br>cleaners |                        | 2 food services aides, 5<br>cleaners, 1 porter              |                        |
|------------------------------|--|------------------------|---|------------------------|
| Equipment                    | Items  | Annual cost for clinic | Items   | Annual cost for clinic |
| Capital cost<br>(annualised) | IT equipment                                       | 905                    | IT equipment , medical<br>equipment, furniture              | 18,555                 |
| Recurrent cost<br>(average)  | Supplies   | 4,191                  | Supplies  | 187,127                |
| Overheads                    | Items  | Annual cost for clinic | Items   | Annual cost for clinic |
| Capital cost<br>(annualised) | N/A  | -                      | Building refurbishment,<br>clinic space, clinic<br>database | 3,000                  |
| Recurrent cost<br>(average)  | Building<br>maintenance, utilities                 | 123,446                | Utilities   | 10,841                 |

At CMH, the average total cost per patient per year on ART was \$1,040 (95% confidence interval, CI, \$800 to \$1,280). The average outpatient cost was \$692 (67% of total cost). The cost of antiretroviral drugs contributed 16% to this cost, with laboratory tests and radiology contributing 50%, fixed costs including staff and overhead costs 31%, and non-ARV drugs 2% (Table 3). Of fixed cost, 95% were due to staff cost, 4% due to building and utility costs, and 1% due to equipment and supplies (data not shown).

At TWC, the average cost of ART provision per patient per year on ART was \$1,115 (95% CI \$776 - \$1,453) (Table 3). The average outpatient cost was almost the same as at CMH, \$697, or 68% of total cost. The largest contributor to outpatient cost was fixed cost with 63%, followed by ARV drug cost (13%), diagnostics cost (21%) and non-ARV drug costs (3%). Of fixed cost, 85% was due to staff cost, 1% due to building cost, and 14% due to equipment and supplies.

**Table 3: Mean annual cost per patient, total and per cost item [2011 USD]**

| Cost item             | Johannesburg (CMH)                                      |                    | Jouberton (TWC)   |                       |
|-----------------------|---|--------------------|---|-----------------------|
|                       | Mean cost per patient year<br>(95% confidence interval) | % of total<br>cost | Mean cost per patient year<br>(95% confidence interval) | % of<br>total<br>cost |
| Total cost            | 1,040 (800-1,280)                                       |                    | 1,115 (776-1,453)                                       |                       |
| Total outpatient cost | 692 (630-754)   | 67                 | 697 (673-720)   | 63                    |
| of which              |   |                    |   |                       |
| ARV drug cost         | 110 (105-115)   | 16 <sup>1</sup>    | 90 (81-99)  | 13 <sup>1</sup>       |
| Non-ARV drug cost     | 17 (13-20)  | 2 <sup>1</sup>     | 18 (15-22)  | 3 <sup>1</sup>        |
| Fixed cost            | 216 (210-222)   | 31 <sup>1</sup>    | 441 (435-446)   | 63 <sup>1</sup>       |
| Diagnostics cost      | 349 (293-405)   | 50 <sup>1</sup>    | 148 (132-164)   | 21 <sup>1</sup>       |
| of which              |   |                    |   |                       |
| Laboratory cost       | 289 (248-330)   | 83 <sup>2</sup>    | 137 (123-152)   | 93 <sup>2</sup>       |
| Radiology cost        | 60 (38-82)  | 17 <sup>2</sup>    | 10 (7-13)   | 7 <sup>2</sup>        |
| Total inpatient cost  | 348 (145-550)   | 33                 | 418 (81-756)  | 37                    |

<sup>1</sup>of total outpatient cost; <sup>2</sup>of total diagnostic cost

### **Inpatient cost and resource use**

At CMH, 26 of the 181 study patients (14%) required inpatient care after the initiation of ART, at a mean length of stay (LOS) of 9 days (range, 1 to 30 days). At a cost per day equivalent to the cost per



PDE in 2007/08 of \$158 (\$176 in 2011 values), the resulting mean cost per hospitalised patient was \$1,663 (95% CI \$1,103 to \$2,041) and mean cost of inpatient care amongst all patients on ART, whether hospitalised or not, was \$348 (28% of total cost) (**Error! Reference source not found.**Table 3). The average time on ART at hospitalisation was 132 days (range, 13 to 363). Thirteen of the hospitalisations were due to opportunistic infections, seven of which occurred in the first three months after initiation, the typical time window for the development of immune reconstitution syndrome. At least eight other admissions were related to side effects of ART (pancytopenia, lactic acidosis, peripheral neuropathy and gastric ulcers).

At TWC, only 12 of the 184 study patients (7%) required inpatient care after the initiation of ART, at an average length of stay of 28 days (range, 1 to 63 days). At a cost per PDE of \$226 in 2007/08 (\$252 in 2011 values), this led to a mean cost per hospitalised patient of \$3,824 (95% CI \$1,143 to \$6,505) and a mean cost of inpatient care amongst all patients on ART of \$418 (32% of total cost). The distribution of hospitalisations over time was rather different than at CMH, with only 23% of hospitalisations and cost within month 1 to 3 and 54% of hospitalisations and total inpatient cost falling into the time period of month 7 to 9 on ART. The average time on ART at hospitalisation was 107 days (range, 2 to 232). Four of the hospitalisations were due to opportunistic infections, with only one occurring in the typical time window for the development of immune reconstitution syndrome. Three of the other admissions were related to side effects of ART (progressive neuropathy and lactic acidosis).

We also analysed whether patients requiring inpatient care also had higher outpatient resource use. At CMH, patients with inpatient resource use had a mean outpatient cost of \$848 (95% CI \$553 to \$1,143), compared to a mean outpatient cost of patients without inpatient resource use of \$662 (95% CI \$612 to \$712) ( $p > 0.2$ ). At TWC, patients with inpatient resource use had a mean outpatient cost of \$734 (95% CI \$677 to \$792), compared to a mean outpatient cost of patients without inpatient resource use of \$693 (95% CI \$668 to \$718) ( $p > 0.1$ ). In summary, although in both clinics mean outpatient cost was somewhat higher for those patients who required inpatient care, the differences were not significant at the  $< 0.05$  level.

#### **Development of cost with time on treatment and with CD4 cell count**

Total cost, including both outpatient and inpatient cost, varied with time on treatment in both clinics, in part as a result of the treatment protocol asking for specific monitoring during the first visits, in part due to the higher incidence of opportunistic infections during the first months on treatment when CD4 cell counts were still low, some of which required hospitalisation. As can be seen in Table 4, the highest cost per 3-month period on ART was found in the first 3 months after ART initiation in both clinics, after which cost decreased with every three months on ART except for the 7-9 month period at TWC which had high inpatient cost. Additionally, in both clinics cost was highest in the lowest stratum ( $< 50$  cells/microl). Differences in mean cost between clinics were not significant at the  $< 0.05$  level in any time period or CD4 cell count stratum except for the 10-12 months on ART time period where

care at TWC was cheaper. Differences in median cost (data not shown) however were significant at the <0.05 level for the 1-3 to 7-9 month periods and the <50 and 50-199 cells/microl CD4 cell count strata.

**Table 4: Mean cost by time on ART and by CD4 cell count stratum, by clinic [2011 USD]**

|                                   | Johannesburg (CMH) |  | Jouberton (TWC) |  |  |  |
|-----------------------------------|--------------------|--|-----------------|--|--|--|
|                                   | n                  | Mean cost per 3-month period (95% confidence interval) | n               | Mean cost per 3-month period (95% confidence interval) | p for comparison of mean cost between clinics (t-test) | p for comparison of median cost between clinics (Wilcoxon sum rank test) |
| <b>Months on ART</b>              |                    |  |                 |  |  |  |
| -3 - 0                            | 181                | 130 (120-141)  | 184             | 128 (121-134)  | 0.6498   | 0.7552   |
| 1 - 3                             | 181                | 276 (190-364)  | 184             | 399 (140-658)  | 0.3753   | <.0001   |
| 4 - 6                             | 177                | 187 (140-235)  | 169             | 190 (109-271)  | 0.9568   | 0.0027   |
| 7 - 9                             | 158                | 136 (106-165)  | 143             | 267 (45-490)   | 0.2491   | <.0001   |
| 10 - 12                           | 126                | 183 (111-255)  | 98              | 103 (89-116)   | 0.0315   | 0.0857   |
| <b>CD4 stratum (cells/microl)</b> |                    |  |                 |  |  |  |
|                                   | n                  | Mean cost per 3-month period (95% confidence interval) | n               | Mean cost per 3-month period (95% confidence interval) | p for comparison of mean cost between clinics (t-test) | p for comparison of median cost between clinics (Wilcoxon sum rank test) |
| <50                               | 93                 | 247 (113-382)  | 120             | 455 (55-854)   | 0.3311   | 0.0031   |
| 50-199                            | 393                | 181 (151-211)  | 392             | 219 (132-305)  | 0.4263   | <.0001   |
| 200-350                           | 244                | 170 (128-213)  | 142             | 136 (117-156)  | 0.1531   | 0.1110   |
| >350                              | 90                 | 166 (117-216)  | 119             | 142 (108-175)  | 0.4155   | 0.1965   |

## DISCUSSION

Our study shows that the cost of ART provision is similar between an urban and semi-urban site, and that in both sites cost is highest at low CD4 cell counts. Nonetheless, average total cost per patient year at TWC was 6% higher than average total cost at CMH, with most of the difference borne by the difference in inpatient cost, which was a result of a number of patients with very long lengths of stay at TWC. The median outpatient cost per patient year in 2011 USD of five previously published analyses of the cost of antiretroviral treatment provision in the South African public sector is \$1,377 (range \$1,204-\$1,438); median inpatient cost in the public sector is \$369 (range \$258 - \$660)<sup>3-7</sup>. The annual per-patient cost of \$1,040-\$1,115 found in both clinics examined in this paper fall within the spectrum found in these past analyses. In our analysis, two factors are associated with higher cost in either clinic: low CD4 cell counts and the higher risk of hospitalisations in the first three months on treatment. Both factors have been described as drivers of the cost of ART provision in previous studies, for both the private sector<sup>5</sup> and the public sector of South Africa<sup>3,4,15</sup>. At both clinics in our study, patients with CD4 counts below 50 cells/microl drive costs significantly in the first 3 months of

treatment, costing between double and triple that of those initiated at CD4 cell counts above that threshold.

Inpatient care periods varied significantly between the two sites, although the small number of patients requiring inpatient care in both cohorts limit the generalisability of this difference. From subsequent discussions with staff at the sites, we believe this is driven by a higher illness threshold for admission in the semi-urban site, radiology investigations and specialist referrals during inpatient care taking longer to arrange, as well as the fact that patients live further away from the hospital and are poorer, leading local clinicians to retaining patients in inpatient care for longer.

Although total cost at the outpatient level is very similar, the contribution of single cost items is different between the settings, reflecting differences in clinic operations: At TWC, fixed cost is almost twice as expensive per patient than at CMH, while average ARV drug cost are only 33% of total outpatient cost, and average diagnostic cost are less than half that at CMH. In all past estimates of ART provision in South Africa, ARV cost contribute at least 50% to total outpatient cost<sup>3-7,16-18</sup>. The higher ART and diagnostics cost at CMH can be explained by more patients having been switched to second line therapy, its academic status and better access to specialist care in the clinic. In contrast, the higher fixed cost at TWC is a result of the higher staff numbers, with the nurse contingent being almost double that of CMH due in part to nurses doubling as translators between doctors and patients. The higher equipment cost for TWC is a result of the clinic operating out of the hospitals previous nurses' quarters, thus requiring higher initial refurbishment and equipment expenditures than CMH where the clinic operates out of a previously established outpatient clinic.

Patients' status after 12 months on antiretroviral treatment and time in the cohort differed significantly between the two clinics, mostly as a result of much higher down-referral at TWC (39% at TWC vs. 3% at CMH). This did not, however, lead to a bias towards sicker patients remaining in the cohort, as from 7 months on ART onwards the mean cohort CD4 cell counts were higher at TWC than at CMH, though not significantly. The increase in down-referral to PHC clinics in the patients' immediate communities at TWC during the study period resulted in part from an analysis of the association between patients' travel cost and loss to follow-up which showed a strong linear relationship between distance travelled and risk of defaulting from care in the study cohort<sup>19,20</sup>. Acting on these findings in 2007 the provincial government of the North-West province accredited a number of additional ART clinics in the immediate vicinity of TWC and the clinic management of TWC accelerated down-referral to these sites as a means of preventing further patients defaulting from ART care. Although this resulted in lower numbers of patients defaulting from care during the remainder of the study, it did lead to a higher overall loss from the cohort through down-referral.

The generalisability of the results of this study is limited by a number of factors. Average cost at both facilities were collected for the first year on treatment and in two clinics only and are at least in part a result of specific operational circumstances (such as the high rate of down-referral during the study

period at TWC); however, costs were similar between the two clinics, as well as compared to other studies, suggesting they are useful to guide policy makers. Differences in clinic populations in terms of poverty level and educational background could have impacted follow-up rates, rendering direct comparison of cost between the clinics difficult - although the distribution of baseline CD4 cell counts, as a proxy for disease severity and case-mix, were very similar at both clinics. The analysis is limited to the resources used by the cohort while in the care of the clinics under study, which means that not all cost of care is included, particularly for patients that were down-referred before the end of the study period. Since the cost of care at those down-referral sites is likely to be lower, this would likely mean that we over-estimate the cost of care for the semi-urban site somewhat. Finally, both clinics are attached to a hospital complex, and most South African patients will in the future be initiated at primary care clinics, limiting generalisability of staff and fixed costs.

## **CONCLUSIONS**

The cost of providing antiretroviral treatment in the public sector of South Africa has been well researched but analysis has so far focused on urban centres. The results presented in this paper show that provision in semi-urban settings costs almost the same at the outpatient level as in urban settings, while inpatient cost tends to be higher as a result of longer lengths of stay. Significant cost reduction within the programme is possible, through identifying, retaining and initiating patients on ART at a higher CD4 cell count, hence preventing hospitalisation, which is the major preventable driver of cost. Task shifting away from professional staff may also offer cost reductions.

Cost at both clinics analysed here fall within the spectrum of cost estimates that are already available for South Africa and that have been used as the average cost per adult patient in government budgeting and planning exercises<sup>21,22</sup>, suggesting that provision at this cost level is expected by government, planned for, and, as a result, potentially sustainable. Recent reductions in staff cost due to task-shifting and in the cost of antiretroviral drugs due to the opening of the South African market to international bidders have brought the cost of ART provision further down<sup>22,23</sup>.

## **Acknowledgements**

We thank Kgomotso Thloaele, Albertina Dambuza, Motlalepule Letsapa and Belinda Dambuza for recruiting and interviewing the patients of the two longitudinal study cohorts, the many patients who agreed to be part of them and sacrificed time and offered information towards this study, and staff at Tshepong and Charlotte Maxeke Hospitals and the National Health Laboratory Services for assistance with providing cost and resource use data, in particular Jeffrey Wing, Sagie Pillay, and Wiebe-Randerjee. We are grateful to Lilani Kumaranayake, Rosa Legood, Richard Grieve, Charlotte Watts and Peter Vickerman for help in conceptualising the analytical framework and methods used in this paper.

## **References**

1. UNAIDS: AIDS epidemic update December 2009. Geneva 2009.
2. Health Budget Vote Policy Speech presented at the National Assembly by Minister of Health, Dr A Motsoaledi, 31 May 2011. Available at [www.info.gov.za/speech](http://www.info.gov.za/speech).
3. Cleary S, McIntyre D, Boule A: The cost-effectiveness of antiretroviral treatment in Khayelitsha, South Africa - a primary data analysis. *Cost Effect Res All.* 2006;4:20.
4. Harling G, Wood R: The evolving cost of HIV in South Africa. *JAIDS* 2007;45:348-54.
5. Leisegang R, Cleary S, Hislop M, et al: Early and late direct costs in a Southern African antiretroviral treatment programme: A retrospective cohort analysis. *PLoS Med.* 2009; 6(12).
6. Long L, Fox M, Sanne I, et al: The high cost of second-line antiretroviral therapy for HIV/AIDS in South Africa. *AIDS* 2010;24:915-919.
7. Rosen S, Long L, Sanne I. The outcomes and outpatient costs of different models of antiretroviral treatment delivery in South Africa. *Trop Med Int Health.* 2008;13(8): 1005-15.
8. National Department of Health, Republic of South Africa. National Strategic Plan for HIV and AIDS & STIs 2007-2011. Pretoria 2007.
9. National Department of Health, Republic of South Africa. Clinical Guidelines for the Management of HIV & AIDS in Adults and Adolescents. Pretoria 2010.
10. South African National AIDS Council and National Department of Health: Final presentations at the Programme Implementation Committee meeting 26 January 2011. Pretoria 2011.
11. National Department of Health, South Africa. National Antiretroviral Treatment Guidelines. Pretoria 2004.
12. Drummond M, O'Brien B, Stoddart G, Torrance G, eds. *Methods for the economic evaluation of health care programmes*. 3rd ed. New York: Oxford University Press; 2005.
13. Accounting Standards Board South Africa: Standard of Generally Recognised Accounting Practice: Property Plant and Equipment (GRAP 176), November 2004.
14. Kumaranayake L: The real and the nominal? Making inflationary adjustments to cost and other economic data. *Health Pol Plann.* 2000;15(2):230-4.
15. Long L, Rosen S, Sanne I. Stable outcomes and costs in South African patients' second year on antiretroviral treatment. Presented at: International AIDS Economics Network Symposium; 2008; Cuernavaca.
16. Martinson N, Mohapi L, Bakos D, et al. Costs of providing care for HIV-infected adults in an urban HIV clinic in Soweto, South Africa. *JAIDS* 2009;50: 327-30
17. Stearns BK, Evans DK, Lutung P, et al. Primary estimates of the costs of ART care at 5 AHF clinics in sub-Saharan Africa [MOPE0706]. Presented at: XVIIth International AIDS Conference; 2008; Mexico City.
18. Kevany S, Meintjes G, Rebe K, et al: Clinical And Financial Burdens of Secondary Level Care In A Public Sector Antiretroviral Roll-out Setting (G F Jooste Hospital). *S Afr Med J.* 2009;99:320-25.
19. Meyer-Rath G, Kumaranayake L, Variava E, et al: Transport costs of patients accessing antiretroviral treatment (ART) in Gauteng and the North-West province. Presented at: South African AIDS Conference; 2007; Durban.
20. Meyer-Rath G, Kumaranayake L, Variava E, et al: Getting people to the pills: Transport costs, socio-economic status and reasons for defaulting from antiretroviral treatment in public sector clinics in South Africa. Presented at: International AIDS Economics Network pre-conference meeting; 2008; Cuernavaca.
21. Cleary S: The costs of the National Strategic Plan on HIV and AIDS & STIs 2007-2011. Pretoria 2007
22. Meyer-Rath G, Pillay Y, Blecher M, et al: Total cost and potential cost savings of the national antiretroviral treatment (ART) programme in South Africa 2010 to 2017. Presented at: XVIII International AIDS Conference; 2010; Vienna.
23. Meyer-Rath G, Pillay Y, Blecher M, et al: The impact of a new reference price list mechanism for drugs on the total cost of the national antiretroviral treatment programme in South Africa 2011 to 2017. Presented at: South African AIDS Conference; 2011; Durban.



## 6 Inpatient cost of adults before and after ART

### Rates and Cost of Hospitalization Before and After Initiation of Antiretroviral Therapy in Urban and Rural Settings in South Africa

1. For a 'research paper' already published
  - 1.1. Where was the work published? **JAIDS**
  - 1.2. When was the work published? **2013**
  - 1.3. Was the work subject to academic peer review? **Yes**
  - 1.4. Have you retained the copyright for the work? **No**

If yes, attach evidence of retention

If no, or if the work is being included in its published format, attach evidence of permission from copyright holder (publisher or other author) to include work **See exemption on next page**

2. For a 'research paper' prepared for publication but not yet published
  - 2.1. Where is the work intended to be published?
  - 2.2. List the paper's authors in the intended authorship order
  - 2.3. Stage of publication – Not yet submitted/Submitted/Undergoing revision from peer reviewers' comments/In press
3. For multi-authored work, give full details of your role in the research included in the paper and in the preparation of the paper. (Attach a further sheet if necessary)

**The candidate conceptualised the study, collaborated with Alana Brennan on the data analysis, and wrote the majority of the first draft of the publication.**

Candidate's signature

Dr Gesine Meyer-Rath

Supervisor or senior author's signature to confirm role as stated in (3)

Dr Alec Miners

Supervisor

Wolters Kluwer  
Health

Lippincott Williams &amp; Wilkins

Requesting permission to  
reuse content from an  
LWW publication.

Title: Rates and Cost of  
Hospitalization  
Before and After  
Initiation of  
Antiretroviral  
Therapy in Urban and  
Rural Settings in  
South Africa

Author: Gesine Meyer-Rath,  
Alana Brennan,  
Matthew Fox, et al

Publication: JAIDS: Journal of  
Acquired Immune  
Deficiency Syndrome

Publisher: Wolters Kluwer  
Health, Inc.

Date: Jan 1, 2013

Copyright © 2013, (C) 2013  
Lippincott Williams

This reuse is free of charge. No permission letter is needed from Wolters Kluwer Health, Lippincott Williams & Wilkins. We require that all authors always include a full acknowledgement. Example: AIDS: 13 November 2013 - Volume 27 - Issue 17 - p 2679-2689. Wolters Kluwer Health Lippincott Williams & Wilkins© No modifications will be permitted.

Copyright © 2015 [Copyright Clearance Center, Inc.](#) All Rights Reserved.  
[Privacy statement.](#) [Terms and Conditions.](#)

Comments? We would like to hear from you. E-mail us at  
[customercare@copyright.com](mailto:customercare@copyright.com)



## ***Preamble for paper 2***

While the primary objective of the National ART Cost Model was to inform the ring-fenced budget item of the HIV/AIDS Conditional Grant, we received an additional request from the Department of Health to include the cost of inpatient care for patients both before and after ART initiation. All public-sector hospitals in South Africa are funded through a separate budget item, the Hospital Grant. Since HIV-positive patients are only a subset of the total inpatient population across disease areas, this additional analysis was not planned to be used to inform the full budget for this grant, but rather add data to help explain recent changes in this grant.

Paper 4 is the first analysis of hospitalisation frequency and costs of HIV-positive patients before and after ART initiation in South Africa that are drawn from the same cohort - i.e., most patients contributed data to both the pre-ART and the ART population. In order to fit the results with the health states used in the model, we further stratified hospitalisation rates and cost by patients' current CD4 count.

Alana Brennan assisted with data analysis for this paper and wrote some sections of the first draft; the candidate shares first authorship with her. All co-authors contributed comments and edited the paper. All other work, including study design, most data analysis, and writing the first and consecutive drafts of the paper, was the candidate's.

## **Paper 2**

### **Rates and cost of hospitalisation before and after initiation of antiretroviral therapy in urban and rural settings in South Africa**

Gesine Meyer-Rath, MD<sup>1,2†\*</sup>, Alana T Brennan, MPH<sup>1,2\*</sup>, Matthew P Fox, DSc<sup>1,2,3</sup>, Tebogo Modisenyane, BSc<sup>4</sup>, Nkeko Tshabangu, RN<sup>4</sup>, Lerato Mohapi, MD<sup>4</sup>, Sydney Rosen, MPA<sup>1,2</sup>, Neil Martinson, MD MPH<sup>4,5</sup>

<sup>1</sup> Center for Global Health and Development, Boston University, Boston, USA

<sup>2</sup> Health Economics and Epidemiology Research Office, Department of Medicine, Faculty of Health Sciences, University of the Witwatersrand, Johannesburg, South Africa

<sup>3</sup> Department of Epidemiology, Boston University School of Public Health, Boston, USA

<sup>4</sup> Perinatal HIV Research Unit, University of the Witwatersrand, Johannesburg, South Africa

<sup>5</sup> Johns Hopkins University, School of Medicine, Baltimore, USA

† **Corresponding author details:** Health Economics and Epidemiology Research Office, Themba Lethu Wing, Helen Joseph Hospital, Perth Road, Westdene, Johannesburg, 2092, South Africa, fax: +27 (11) 276 8885, email: [gesine@bu.edu](mailto:gesine@bu.edu)

\*These authors share senior authorship.

**Meetings at which parts of the data were presented:** 15th International Workshop on HIV Observational Databases 2011, Prague, 24 March 2011 (Abstract no. 15\_29) (closed meeting without publication)

**Source of Support:** Funding for this study was provided by the United States Agency for International Development (USAID) under an award to Boston University (674-A-00-09-00018-00). Patient care was funded by the President's Emergency Plan for AIDS Relief (PEPFAR), through USAID (674-A-00-05-00003-00). MPF was supported by a grant from the National Institute of Allergy and Infectious Diseases (NIAID) (K01AI083097). TM received research training funded by a Fogarty International Center grant (U2RTW007370/3). NM is partially funded by a grant from the National Institutes of Health (NIH) (R01HL090312). The opinions expressed herein are those of the authors and do not necessarily reflect the views of NIH, NIAID, USAID, PEPFAR, the University of the Witwatersrand, Boston University, or Johns Hopkins University.

**Potential Conflicts of Interest:** The authors declare that they have no conflicts of interest.

## ABSTRACT

Few studies have compared hospitalisations before and after antiretroviral therapy (ART) initiation in the same patients. We analysed the cost of hospitalisations among 3,906 adult patients in two South African hospitals, 30% of whom initiated ART. Hospitalisations were 50% and 40% more frequent and 1.5 and 2.6 times more costly at a CD4 cell count <100 cells/microl when compared to 200-350 cells/microl in the pre-ART and ART period, respectively. Mean inpatient cost per patient year was USD 117 (95% confidence interval, CI, 85-158) for patients on ART and USD 72 (95% CI, 56-89) for pre-ART patients. Raising ART eligibility thresholds could avoid the high cost of hospitalisation before and immediately after ART initiation.

**Keywords:** hospitalisation, in-patient, admission, resource-limited setting, pre-ART

## INTRODUCTION

Worldwide, the introduction of antiretroviral therapy (ART) has resulted in a large decrease in hospital admissions amongst HIV-positive patients. Analyses from seven North American and European countries showed a decrease in frequency, average length of hospital stay, and cost per stay of between 32% and 77% in patients on ART compared to those not on ART[1-9]. The reduction in cost due to decreased need for inpatient care has been used to make the economic case for public-sector provision of ART in many high-income countries[10-18]. Initiating ART at low CD4 cell counts, however, has been strongly associated with high inpatient costs[3,4]. Data from low- and middle-income countries show that a significant number of HIV-infected patients on ART still require hospitalisation, especially those initiating at low CD4 counts [19-23].

Few studies have measured rates of hospitalisation in a single cohort both before and after ART initiation to evaluate the effect of treatment on hospital admissions[10,17,22,24,25]. South Africa, a middle-income country, started its public-sector ART programme in 2004. Though several studies have examined the programme's cost and cost-effectiveness[19,20,22-30], only a handful have included a description of inpatient cost in patients on and off ART in the public sector[20,24,26,27]. None of these studies controlled for patients' CD4 count, making it hard to compare studies across cohorts with different levels of disease severity.

To establish whether ART reduces hospitalisations while controlling for the patients' CD4 counts, we compared hospitalisation rates and costs in a South African cohort of HIV-positive patients before and after ART initiation stratified by patients' current CD4 count.

## METHODS

We analysed data from an adult HIV cohort study[31-33] conducted from July 2003 to October 2010 at Chris Hani Baragwanath Hospital, a large, urban, tertiary hospital in Soweto in Gauteng Province, and Tintswalo Hospital, a rural hospital in Mpumalanga Province. Patients were recruited after testing HIV positive in the same hospital and were provided with pre-ART HIV care (regular clinic visits for CD4 count monitoring and nurse-led care for opportunistic infections) and initiated on ART once diagnosed with WHO stage 4 disease or a CD4 count <200 cells/microl[34,35]. Recruiting at HIV testing allowed us to include a sizable group of patients who were followed up until they became ART eligible and then were started on ART and continued to be followed up. Eligible patients for this analysis were  $\geq 18$  years old with at least one follow-up visit and one CD4 count after enrolment into the study. Participants were interviewed about their demographic and socioeconomic characteristics and medical history at baseline and about admission and discharge dates of hospitalisations and reasons for admission both at baseline and at follow-up visits four to seven months apart. CD4 counts were collected at enrolment and up to six-monthly thereafter.

Patient baseline characteristics were summarised using descriptive statistics. Hospital admissions occurring during pre-ART and ART periods were stratified by most recent CD4 count in the same six-month time period as the admission. For this we divided person-time for each subject into 6-month periods, starting at enrolment into the study for pre-ART person-time and the date of treatment initiation for person-time on ART. For each 6-month period a patient contributed one observation indicating whether hospitalisation occurred in this period, as well as a current CD4 cell count, which was the first CD4 cell count within that period of observation. For missing CD4 count data (30.2%), we created 25 randomly imputed datasets each for the pre-ART and the ART populations, with missing values modeled on existing data (hospitalisation, site, square root of available CD4 counts and time from either enrolment or ART initiation), and took the mean of the imputed CD4 counts for each missing observation[36]. We estimated incident rate ratios (IRR) of hospitalisation stratified by CD4 counts in the same six-month period.

We estimated the cost of hospitalisations from the health care provider perspective using cohort data on length of stay and the 2008 cost per patient-day equivalent (PDE) of the hospitals' districts[37]. The cost per PDE is a proxy of cost per inpatient-day and is collected by all public-sector hospitals in South Africa, dividing total hospital expenditure during a financial year by the total number of hospital visits[38]. The cost per PDE for Baragwanath Hospital was USD 164.19, and the cost per PDE for Tintswalo Hospital was USD 176.29. All costs are presented in 2009 USD using the 2009 average currency conversion rate of 1 USD=7.11 ZAR.

Ethical approval was granted by review boards of the University of the Witwatersrand and Boston University.

## RESULTS

### Patient characteristics

Of 3,906 patients in our analysis, 140 (3.6%) initiated ART prior to enrolment into the study and 913 (23.4%) initiated ART after being enrolled. Overall patients were predominately female (76.6%) with a median age of 33 years (inter-quartile range, IQR, 28-39). Pre-ART patients had a median CD4 count of 269 cells/microl (IQR 136-442) at study enrolment, while ART patients had a median CD4 count of 154 cells/microl (IQR 91-239) at study enrolment which declined to a median CD4 count of 117 cells/microl (IQR 57-183) at treatment initiation. Median time in pre-ART care prior to initiation onto ART was 7.0 months (IQR 1.5-15.9). Patients on treatment were predominately (71%) treated with stavudine, lamivudine and efavirenz, the most common first-line regimen in South Africa until 2010.

### Frequency of hospitalisations

Among the 3,906 patients, 534 hospitalisations occurred during a median follow-up of 13.1 months (IQR 6.3-28.2). 344 (64%) hospitalisations were in pre-ART patients, while 190 (36%) occurred after ART initiation (Table 1). Most patients had a single admission; however, 28 patients in the pre-ART period and 19 patients in the ART period had more than one admission, with a maximum of 5 and 4 admissions per patient in the pre-ART and ART period, respectively. The leading reasons for admission in patients not on ART were pulmonary tuberculosis (TB) (15.1%), *Pneumocystis jirovecii* pneumonia (6.4%), and trauma (5.5%); in patients on ART they were pulmonary TB (15.2%), *Pneumocystis jirovecii* pneumonia (7.9%), and headache of any kind (6.8%). The incidence of hospitalisations related to pulmonary TB was 0.74 and 1.0 per 100 patient years in the pre-ART and ART period, respectively; the incidence of admissions for extrapulmonary TB was 0.13 and 0.3 per 100 patient years, respectively. During the first 6 months on ART, the incidence of admissions for pulmonary TB was, at 2.8 per 100 patient years, almost 3 times as high, pointing at the possibility of immune constitution syndrome.

As current CD4 count increased, the rate of hospitalisation decreased. Hospitalisation rates were highest for patients with CD4 counts  $\leq 100$  cells/microl. Patients with a CD4 count of  $>350$  cells/microl had a reduction in the rate of hospitalisation compared with patients with a CD4 count of  $<100$  cells/microl of 70% pre-ART, and of 80% under ART (pre-ART IRR 0.3, 95%CI: 0.2-0.5; ART IRR 0.2, 95% CI: 0.1-0.3). Hospitalisation rates were higher for ART patients than pre-ART patients in all CD4 strata, with most of this difference being driven by the rural cohort, a much smaller population. When removing events unlikely to be HIV related (trauma and accidents; 43 events in the pre-ART period and 6 in the ART period), events in patients initiating ART with a CD4 cell count above 200 cells/microl, and all events in the first 3 months after ART initiation, the average rates of hospitalisation in the pre-ART and ART cohorts did not change, and the effect was still significant (Table 2A-2C).

### Cost of hospitalisations

Mean length of stay (LOS) per hospitalisation was 8.7 days (95% confidence interval, CI, 7.5-9.9) for pre-ART patients and 10.1 days (8.4-11.8) for ART patients and decreased with increasing CD4 count in both populations (Table 1). Mean LOS was slightly higher amongst ART vs. pre-ART patients in all CD4 strata except at >350 cells/microl and was higher in the rural clinic, regardless of ART status. As a result, the inpatient cost per patient year was higher for ART patients in every stratum, and higher in the rural than in the urban site in almost all strata, partly due to the higher rural cost per PDE. The resulting mean inpatient cost per patient year for ART patients was 63% higher than for pre-ART patients (USD 117 vs. 72). Regardless of treatment status, hospital stays were longest and most costly in patients with a CD4 count <100 cells/microl, with mean inpatient cost per patient year being 4 times higher at <100 cells/microl than at >350 cells/microl in the pre-ART period, and 9 times higher in the ART period. Combined hospitalisation rates for both sites after removing events not related to HIV, in patients initiating ART at CD4 cell counts > 200, and during the first three months after ART initiation are available in the technical appendix of this paper.

Figure 1 shows inpatient cost as a function of CD4 count over the lifetime of a representative patient, extrapolated from the mean inpatient cost per CD4 cell count stratum found in our analysis.

**Figure 1: Schematic of development of CD4 cell count and inpatient cost per patient year before and after ART initiation.**

ART indicates antiretroviral therapy; USD, US dollars. CD4 cell count development is modelled for a hypothetical individual, based on a summary of South African cohort studies[38]; inpatient cost is based on the mean inpatient cost per patient year by CD4 cell count stratum in this study.

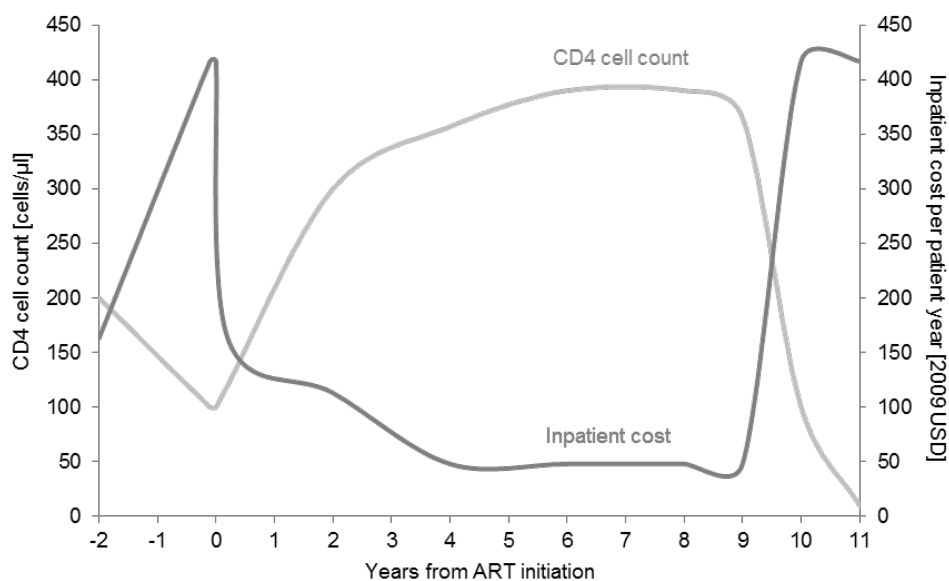

**Table 1: Hospitalisation rates and cost by current CD4 cell count and site (urban versus rural) in patients before and after ART initiation in a prospective cohort study in two sites in South Africa.**

| CD4 cell count stratum | Total patient years (%) | Number of hospitalisations | Hospitalisation rate per 100 patient years (95% CI) | Crude IRR of hospitalisation by CD4 count (95% CI) | Mean length of stay [days] (95% CI) | Mean cost per stay [2009 USD] (95% CI) | Mean inpatient cost per patient year in cohort [2009 USD] (95% CI) |
|------------------------|-------------------------|----------------------------|---|--|-------------------------------------|--|--|
| <b>Both sites</b>      |                         |                            |   |  |                                     |  |  |
| <b>Pre-ART</b>         |                         |                            |   |  |                                     |  |  |
| ≤100 cells/microl      | 602.8 (8.6)             | 60                         | 10.0 (7.6-12.8)                                     | 1.0  | 10.4 (7.4-13.4)                     | 1,759 (1,254-2,263)                    | 176 (95-290)   |
| 101-200 cells/microl   | 1,233.9 (17.6)          | 78                         | 6.3 (5.0-7.9)                                       | 0.6 (0.4-0.9)                                      | 8.6 (5.9-11.2)                      | 1,453 (988-1,919)                      | 92 (49-152)  |
| 201-350 cells/microl   | 2,275.6 (32.5)          | 109                        | 4.8 (3.9-5.8)                                       | 0.5 (0.3-0.7)                                      | 8.7 (6.7-10.6)                      | 1,452 (1,126-1,778)                    | 70 (44-103)  |
| >350 cells/microl      | 2,889.5 (41.3)          | 97                         | 3.4 (2.7-4.1)                                       | 0.3 (0.2-0.5)                                      | 7.8 (5.6-10.0)                      | 1,290 (934-1,645)                      | 44 (25-67)   |
| All pre-ART patients   | 7,001.7                 | 344                        | 4.9 (4.4-5.4)                                       | -  | 8.7 (7.5-9.9)                       | 1,460 (1,267-1,657)                    | 72 (56-89)   |
| <b>On ART</b>          |                         |                            |   |  |                                     |  |  |
| ≤100 cells/microl      | 134.8 (5.3)             | 27                         | 20.0 (13.2-29.1)                                    | 1.0  | 12.1 (6.6-17.5)                     | 2,043 (1,128-2,957)                    | 409 (149-860)  |
| 101-200 cells/microl   | 456.9 (17.4)            | 44                         | 9.6 (7.0-12.9)                                      | 0.5 (0.3-0.8)                                      | 13.4 (8.0-18.7)                     | 2,241 (1,345-3,137)                    | 216 (94-405)   |
| 201-350 cells/microl   | 1024.8 (35.2)           | 75                         | 7.3 (5.8-9.2)                                       | 0.4 (0.2-0.6)                                      | 9.3 (7.4-11.2)                      | 1,559 (1,241-1,876)                    | 114 (72-173)   |
| >350 cells/microl      | 1123.7 (42.1)           | 44                         | 3.9 (2.8-5.3)                                       | 0.2 (0.1-0.3)                                      | 6.9 (4.8-9.0)                       | 1,158 (805-1,511)                      | 45 (23-80)   |
| All ART patients       | 2740.2                  | 190                        | 6.9 (6.0-8.0)                                       | -  | 10.1 (8.4-11.8)                     | 1,693 (1,409-1,976)                    | 117 (85-158)   |
| <b>Urban clinic</b>    |                         |                            |   |  |                                     |  |  |
| <b>Pre-ART</b>         |                         |                            |   |  |                                     |  |  |
| ≤100 cells/microl      | 357.2 (6.9)             | 40                         | 11.2 (8.0-15.2)                                     | 1.0  | 8.9 (4.9-13.0)                      | 1,465 (801-2,129)                      | 164 (64-324)   |
| 101-200 cells/microl   | 827.1 (16.0)            | 57                         | 6.9 (5.2-8.9)                                       | 0.6 (0.4-0.9)                                      | 6.4 (5.2-7.5)                       | 1,049 (861-1,236)                      | 72 (45-110)  |
| 201-350 cells/microl   | 1,695.6 (32.6)          | 88                         | 5.2 (4.2-6.4)                                       | 0.5 (0.3-0.7)                                      | 7.6 (5.8-9.5)                       | 1,256 (950-1,562)                      | 65 (40-100)  |
| >350 cells/microl      | 2,314.6 (44.6)          | 90                         | 3.9 (3.1-7.8)                                       | 0.3 (0.3-0.5)                                      | 7.6 (5.3-9.9)                       | 1,253 (876-1,631)                      | 49 (27-127)  |
| All pre-ART patients   | 5,194.5                 | 275                        | 5.3 (4.7-5.9)                                       | -  | 7.6 (6.4-8.7)                       | 1,242 (1,057-1,428)                    | 66 (50-84)   |
| <b>On ART</b>          |                         |                            |   |  |                                     |  |  |
| ≤100 cells/microl      | 96.1 (4.4)              | 16                         | 16.6 (9.5-27.0)                                     | 1.0  | 12.0 (3.6-20.4)                     | 1,970 (595-3,345)                      | 328 (57-903)   |
| 101-200 cells/microl   | 355.0 (16.1)            | 34                         | 9.6 (6.6-13.4)                                      | 0.6 (0.3-1.0)                                      | 12.3 (6.1-18.4)                     | 2,014 (1,001-3,027)                    | 193 (66-406)   |
| 201-350 cells/microl   | 833.7 (37.8)            | 53                         | 6.4 (4.8-8.3)                                       | 0.4 (0.2-0.7)                                      | 9.3 (6.8-11.8)                      | 1,524 (1,110-1,938)                    | 97 (53-161)  |
| >350 cells/microl      | 918.5 (41.7)            | 34                         | 3.7 (2.6-5.2)                                       | 0.2 (0.1-0.4)                                      | 6.4 (3.9-8.9)                       | 1,053 (648-1,457)                      | 39 (17-76)   |
| All ART patients       | 2203.3                  | 137                        | 6.2 (5.2-7.4)                                       | -  | 9.6 (7.5-11.7)                      | 1,581 (1,239-1,923)                    | 98 (64-142)  |

ART: antiretroviral treatment; CI: confidence interval; IRR: incidence rate ratio

| <b>Rural clinic</b>  |              |    |                  |                |                 |                     |                |
|----------------------|--------------|----|------------------|----------------|-----------------|---------------------|----------------|
| <b>Pre-ART</b>       |              |    |                  |                |                 |                     |                |
| ≤100 cells/microl    | 245.6 (13.6) | 20 | 8.1 (5.0-12.6)   | 1.0            | 13.3 (9.1-17.5) | 2,345 (1,608-3,081) | 191 (80-388)   |
| 101-200 cells/microl | 406.7 (22.5) | 21 | 5.2 (3.2-7.9)    | 0.6 (0.3-1.4)  | 14.5 (5.1-23.9) | 2,552 (894-4,210)   | 132 (29-333)   |
| 201-350 cells/microl | 580.0 (32.1) | 21 | 3.6 (2.2-5.5)    | 0.4 (0.2-0.9)  | 12.9 (6.6-19.2) | 2,275 (1,171-3,379) | 82 (26-186)    |
| >350 cells/microl    | 574.9 (31.8) | 7  | 1.2 (0.5-2.5)    | 0.1 (0.06-0.4) | 10.0 (4.4-15.6) | 1,763 (776-2,750)   | 21 (4-69)      |
| All pre-ART patients | 1,807.1      | 69 | 3.8 (3.0-4.8)    | -              | 13.2 (9.7-16.7) | 2,328 (1,716-2,939) | 89 (51-141)    |
| <b>On ART</b>        |              |    |                  |                |                 |                     |                |
| ≤100 cells/microl    | 38.7 (7.2)   | 11 | 28.4 (14.2-50.9) | 1.0            | 12.2 (4.7-19.7) | 2,148 (826-3,469)   | 611 (117-1766) |
| 101-200 cells/microl | 101.9 (19.0) | 10 | 9.8 (4.7-18.0)   | 0.3 (0.1-0.9)  | 17.1 (4.4-19.8) | 3,015 (783-5,246)   | 296 (37-944)   |
| 201-350 cells/microl | 191.1 (35.6) | 22 | 11.5 (7.2-17.4)  | 0.4 (0.2-0.9)  | 9.3 (6.7-12.0)  | 1,643 (1,174-2,111) | 189 (85-367)   |
| >350 cells/microl    | 205.2 (38.2) | 10 | 4.9 (2.3-9.0)    | 0.2 (0.06-0.4) | 8.6 (3.9-13.2)  | 1,516 (692-2,340)   | 74 (16-211)    |
| All ART patients     | 536.9        | 53 | 9.9 (7.4-12.9)   | -              | 11.2 (8.4-14.1) | 1,982 (1,473-2,492) | 196 (109-321)  |



### Impact on the average inpatient cost per patient in the national treatment programme

We parameterised a previously published model of the cost of the South African national ART programme[40,41] with the results of this analysis. Between financial years 2012/13 and 2016/17, the total inpatient cost of patients on ART is projected to increase from USD 85 million per year to USD 121 million (5% of total programme cost) as a result of a planned increase in patient numbers from the current 1.7 million to 3.6 million in 2017. The mean inpatient cost per patient year on ART, however, will decrease by 9% from USD 37 to USD 34 as a result of a maturation of the cohort on ART and redistribution into higher CD4 counts. From 2010/11 onwards, the average annual inpatient cost of patients on ART is lower than that of patients not on ART (Figure 2).

**Figure 2: Mean inpatient cost per patient year pre-ART and on ART in the national ART programme**

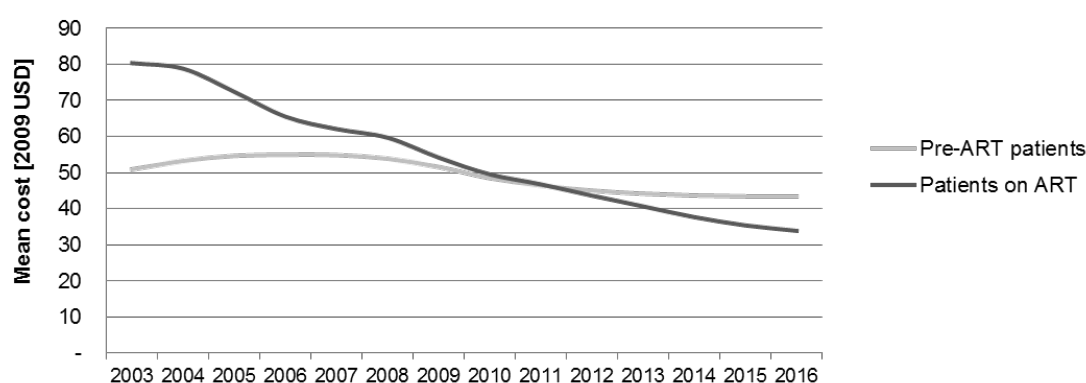

## DISCUSSION

Our study shows that, as in high-income countries[3,4], hospitalisations in HIV-infected adults in South Africa are more frequent, longer, and more costly at lower CD4 counts. We found this to be true regardless of ART status. Patients on ART were hospitalised more often and for longer durations than pre-ART patients. This difference can be explained in part by a higher risk of immune constitution syndrome (IRIS) in patients initiating ART at lower CD4 counts, especially in a population with high TB co-infection rates[21,42]. The incidence of hospitalisations related to pulmonary and extrapulmonary tuberculosis, the opportunistic infections most frequently associated with IRIS in South Africa[21,42], was higher in the ART than in the pre-ART cohort, and highest in the 6 months immediately after ART initiation. Likewise, the difference in hospitalisation frequency and cost between the pre-ART and ART populations was driven by the rural population and could at least in part be due to a bias of physicians towards patients on ART who they have already invested in and whose prognosis is far better.

Similar to our analysis, three of four studies of the cost of inpatient care for public-sector patients on ART in South Africa showed an increase in inpatient care cost for patients on ART, with a median inpatient cost per stay in 2009 USD of USD 1,769 (range 1,319 - 2,080)[19,20,27]. Our mean cost per

stay of patients on ART of USD 1,642 is comparable. A study of a private South African medical aid programme showed a dramatically increased inpatient cost in the 6 months around ART initiation, when CD4 cell counts are at their lowest[22]. When comparing our mean annual per patient inpatient cost of USD 110 to the median cost of outpatient care in 2009 USD for patients on ART in South Africa from a number of published studies, USD 1,233 (range 1,078 to 1,287)[23,28-30], inpatient care adds about 10% to the total annual per patient cost of a patient on ART. It thus accounts for a small but not trivial share of the total cost of caring for HIV/AIDS patients in South Africa.

A potential limitation of our study is the assumption that the published cost per patient-day equivalent is a good proxy for the inpatient costs of HIV-positive patients, which could lead to an over- or underestimation of real inpatient cost. However, a recent in-depth study of the inpatient cost of patients on ART in a different hospital in Johannesburg has shown that cost per PDE is very similar to total per day cost as evaluated in a bottom-up cost analysis using the detailed review of inpatient files[19]. Secondly, since our study cohort had a higher median CD4 count at ART initiation than most public-sector clinics in South Africa, the cost of inpatient care for patients on ART was lower than is likely in routine care. Lastly, while diagnoses were available for all admissions included in this study, their accuracy was somewhat limited by the experience and expertise of the attending health care workers as well as their access to diagnostic modalities, especially in the rural cohort.

## **CONCLUSION**

Our findings provide evidence to support earlier initiation of ART in low- and middle-income countries. We saw a decrease in hospital admission rates by 50%, and of cost by 250%, when comparing CD4 200-350 to  $\leq 100$  in the pre-ART period. Currently, allowing patients' CD4 counts to drop to very low levels before initiating them on ART burdens the health system three-fold: firstly through the high cost of inpatient care immediately before and after ART initiation, then with the cost of life-long ART, and finally with the high cost of end-of-life care once limited treatment options are exhausted. One of the benefits of initiating patients on ART at higher CD4 counts could be avoiding the first of these costs. In the absence of sufficient drug options to avoid the third, terminal cost, and in a situation of decreasing international funding for ART programmes in low- and middle-income countries, avoiding the depletion of patients' CD4 cells and the associated high likelihood of expensive inpatient care is one of the few options available to national ART programmes to reduce the costs of HIV care.

**Acknowledgments:** GMR and ATB designed the study, analysed and interpreted data and wrote the first draft of the paper. MPF and SR contributed to data analysis and interpretation. TM and NT contributed to data acquisition and analysis. LM contributed to data acquisition and interpretation. NM helped design the study and contributed to data interpretation. All authors helped draft and revise the article. We thank the patients attending the study clinics for the readiness to share their data.

## **References**

1. Beck EJ, Mandalia S, Griffith R, et al. Use and cost of hospital and community service provision for children with HIV infection at an English HIV referral centre. *Pharmacoeconomics* 2000;17:53-69.
2. Baum SE, Morris JT, Gibbons RV, et al. Reduction in human immunodeficiency virus patient hospitalizations and nontraumatic mortality after adoption of highly active antiretroviral therapy. *Military Medicine* 1999;164:609-612.
3. Mouton Y, Alfandari S, Valette M, et al. Impact of protease inhibitors on AIDS-defining events and hospitalizations in 10 French AIDS reference centres. Federation National des Centres de Lutte contre le SIDA. *AIDS* 1997;11:F101-5.
4. Krentz HB, Auld MC, Gill MJ. The high cost of medical care for patients who present late (CD4 <200 cells/microL) with HIV infection. *HIV Med* 2004;5:93-8.
5. Nykamp D, Barnett CW, Lago M, et al. Cost of medication therapy in ambulatory HIV-infected patients. *Ann Pharmacother* 1997;31:303-7.
6. Krentz HB, Auld MC, Gill MJ. The changing direct costs of medical care for patients with HIV/AIDS, 1995-2001. *CMAJ* 2003;169:106-10.
7. Garattini L, Tediosi F, Di Cintio E, et al. Resource utilization and hospital cost of HIV/AIDS care in Italy in the era of highly active antiretroviral therapy. *AIDS Care* 2001;13:733-41.
8. Stoll M, Claes C, Schulte E, Graf von der Schulenburg JM, Schmidt RE. Direct costs for the treatment of HIV-infection in a German cohort after the introduction of HAART. *Eur J Med Res* 2002;7:463-71.
9. Kyriopoulos JE, Geitona MA, Paparizos VA, et al. The impact of new antiretroviral therapeutic schemes on the cost for AIDS treatment in Greece. *J Med Syst* 2001;25:73-80.
10. Sendi PP, Craig BA, Meier G, Pfluger D, Gafni A, Opravil M, et al. Cost effectiveness of highly active antiretroviral therapy in HIV-infected patients. *AIDS* 1999;13:1115-22.
11. Freedberg KA, Losina E, Weinstein MC, et al. The cost effectiveness of combination antiretroviral therapy for HIV disease. *N Engl J Med* 2001;344:824-31.
12. Schackman BR, Goldie SJ, Weinstein MC, et al. Cost-effectiveness of earlier initiation of antiretroviral therapy for uninsured HIV-infected adults. *Am J Public Health* 2001;91:1456-63.
13. Beck E, Mandalia S, Gaudreault M, et al. The cost-effectiveness of highly active antiretroviral therapy, Canada 1991-2001. *AIDS* 2004;18:2411-8.
14. Miners A, Sabin C, Trueman P, et al. Assessing the cost-effectiveness of highly active antiretroviral therapy for adults with HIV in England. *HIV Medicine* 2001;2:52-8.
15. Le Pen C, Rozenbaum W, Downs A, et al. Une analyse cout-efficacité du changement des schémas thérapeutiques dans le VIH depuis 1996. *Thérapie* 2002 ;57:27-33.
16. Kowalik E, Jakubczyk M, Niewada M, et al. The cost-effectiveness of antiretroviral regimens containing protease inhibitors (PIS) or nonnucleoside reverse transcriptase inhibitors (NNRTI) in the treatment of HIV-infected individuals in Poland [abstract]. *Value in Health* 2002;5:569.
17. Lacey L, Youle M, Trueman P, et al M. A prospective evaluation of the cost effectiveness of adding lamivudine to zidovudine-containing antiretroviral treatment regimens in HIV infection. European perspective. *Pharmacoeconomics* 1999;15(Suppl 1):39-53.
18. Pinto JL, Lopez Lavid C, Badia X, et al. Análisis coste-efectividad del tratamiento antirretroviral de gran actividad en pacientes infectados por el VIH asintomáticos. *Med Clin (Barc)* 2000;114(Suppl 3):62-7.
19. Long L, Fox M, Rosen S: Cost of hospitalization for those presenting at an HIV treatment center in South Africa [THPE0859]. Presented at: XVIII International AIDS Conference; 2010; Vienna.
20. Smith de Cherif TK, Schoeman JH, Cleary S, et al: Early severe morbidity and resource utilization in South African adults on antiretroviral therapy. *BMC Inf Dis* 2009;9:205.
21. Murdoch DM, Venter WD, Feldman C, et al. Incidence and risk factors for the immune reconstitution inflammatory syndrome in HIV patients in South Africa: a prospective study. *AIDS* 2008;22:601-10.

22. Leisegang R, Cleary S, Hislop M, et al: Early and late direct costs in a Southern African antiretroviral treatment programme: A retrospective cohort analysis. *PLoS Med* 2009;6(12):e1000189.
23. Stearns BK, Evans DK, Lutung P, et al. Primary estimates of the costs of ART care at 5 AHF clinics in sub-Saharan Africa [MOPE0706]. Presented at: XVIIth International AIDS Conference; 2008; Mexico City.
24. Harling G, Wood R: The evolving cost of HIV in South Africa. *JAIDS* 2007;45:348-54.
25. Marseille E, Kahn JG, Pietter C, et al: The Cost-Effectiveness of Home-Based Provision of Antiretroviral Therapy in Rural Uganda. *Appl Health Econ Health Policy* 2009;7(4):229–243.
26. Cleary S, McIntyre D, Boulle A: The cost-effectiveness of antiretroviral treatment. *Cost Effectiveness and Resource Allocation* 2006;4:20.
27. Thomas LS, Manning A, Holmes CB, et al: Comparative Costs of Inpatient Care for HIV-Infected and Uninfected Children and Adults in Soweto, South Africa. *JAIDS* 2007;46:410-6.
28. Martinson N, Mohapi L, Bakos D, et al. Costs of providing care for HIV-infected adults in an urban HIV clinic in Soweto, South Africa. *JAIDS* 2009;50:327-30.
29. Long L, Rosen S, Sanne I. Stable outcomes and costs in South African patients' second year on antiretroviral treatment [abstract]. Presented at: International AIDS Economics Network Symposium; 2008; Cuernavaca.
30. Rosen S, Long L, Sanne I. The outcomes and outpatient costs of different models of antiretroviral treatment delivery in South Africa. *Trop Med Int Health* 2008;13:1005-15.
31. Chhagan V, Luiz J, Mohapi L, et al. The socioeconomic impact of antiretroviral treatment on individuals in Soweto, South Africa. *Health Sociol Rev* 2008;17:95–105.
32. Golub J, Pronyk P, Mohapi L, Thsabangu N, Moshabela M, Struthers H, et al. Isoniazide preventive therapy, HAART and tuberculosis risk in HIV-infected adults in South Africa: a prospective cohort. *AIDS* 2009;23:631-6.
33. Hanrahan CF, Golub JE, Mohapi L, et al. Body mass index and risk of tuberculosis and death. *AIDS* 2010;24:1501-8.
34. National Department of Health, Republic of South Africa (2004). *National Antiretroviral Treatment Guidelines*. Pretoria: Jacana Publishers; 2004.
35. World Health Organization. Towards universal access: scaling up priority HIV/AIDS interventions in the health sector. Geneva; 2008.
36. Schafer JL, *Analysis of Incomplete Multivariate Data*. Boca Raton: Chapman & Hall/CRC; 1997.
37. The District Health Barometer 2008/09. Available at: [www.hst.org.za/publications/district-health-barometer-200809](http://www.hst.org.za/publications/district-health-barometer-200809)
38. National Department of Health: *National Indicator Dataset for South Africa*. Pretoria; 2005.
39. Havlir DV, Getahun H, Sanne I, et al: Opportunities and Challenges for HIV Care in Overlapping HIV and TB Epidemics. *JAMA* 2008;300:423-30.
40. Meyer-Rath G, Pillay Y, Blecher M, et al: Total cost and potential cost savings of the national antiretroviral treatment (ART) programme in South Africa 2010 to 2017 [WEAE0201]. Presented at: XVIII International AIDS Conference; 2010; Vienna.
41. Meyer-Rath G, Pillay Y, Blecher M, et al: The impact of a new reference price list mechanism for drugs on the total cost of the national antiretroviral treatment programme in South Africa 2011 to 2017 [621]. Presented at: South African AIDS Conference; 2011; Durban.
42. Meintjes G, Rabie H, Wilkinson RJ, et al. Tuberculosis-associated immune reconstitution inflammatory syndrome and unmasking of tuberculosis by antiretroviral therapy. *Clin Chest Med* 2009;30:797-810.

Technical appendix: Re-analysis of hospitalisation rates for both sites after removing events not related to HIV, in patients initiating ART at CD4 cell counts > 200, and during the first three months after ART initiation

**Table 2A: Hospitalisation rates and cost by current CD4 cell count with non-HIV related events removed**

| CD4 cell count stratum | Total patient years (%) | Number of hospitalisations | Hospitalisation rate per 100 patient years | Mean length of stay [days] (95% CI) | Mean cost per stay [2009 USD] (95% CI) | Mean inpatient cost per patient year in cohort [2009 USD] |
|------------------------|-------------------------|----------------------------|--|-------------------------------------|--|---|
| <b>Both sites</b>      |                         |                            |  |                                     |  |   |
| <b>Pre-ART</b>         |                         |                            |  |                                     |  |   |
| ≤100 cells/microl      | 591.9 (8.6)             | 59                         | 9.9 (7.6-12.9)                             | 9.8 (6.6-13.0)                      | 1,749 (1,236-2,263)                    | 138 (94-292)  |
| 101-200 cells/microl   | 1,216.6 (17.8)          | 76                         | 6.2 (4.9-7.8)                              | 8.1 (5.3-10.9)                      | 1,485 (1,009-1,961)                    | 113 (49-153)  |
| 201-350 cells/microl   | 2,215.2 (32.3)          | 99                         | 4.5 (3.6-5.4)                              | 7.8 (5.7-9.9)                       | 1,443 (1,090-1,795)                    | 58 (39-97)  |
| >350 cells/microl      | 2,825.4 (41.3)          | 92                         | 3.2 (2.6-4.9)                              | 6.4 (4.3-8.4)                       | 1,207 (869-1,544)                      | 39 (23-76)  |
| All pre-ART patients   | 6,849.1                 | 326                        | 4.7 (4.3-5.3)                              | 7.8 (6.6-9.0)                       | 1,442 (1,240-1,643)                    | 68 (53-87)  |
| <b>On ART</b>          |                         |                            |  |                                     |  |   |
| ≤100 cells/microl      | 133.9 (5.0)             | 26                         | 19.4 (12.7-28.5)                           | 12.3 (6.7-18.0)                     | 2,089 (1,143-3,036)                    | 406 (145-865)   |
| 101-200 cells/microl   | 452.4 (16.8)            | 44                         | 9.7 (7.1-13.1)                             | 13.4 (8.0-18.7)                     | 2,241 (1,345-3,137)                    | 218 (95-411)  |
| 201-350 cells/microl   | 1001.3 (37.3)           | 70                         | 7.0 (5.4-8.8)                              | 9.5 (7.4-11.5)                      | 1,586 (1,249-1,923)                    | 111 (67-169)  |
| >350 cells/microl      | 1097.6 (40.9)           | 42                         | 3.8 (2.8-5.2)                              | 7.0 (4.8-9.2)                       | 1,173 (804-1,542)                      | 45 (23-80)  |
| All ART patients       | 2,685.2                 | 182                        | 6.8 (5.8-7.8)                              | 10.2 (8.5-12.0)                     | 1,721 (1,426-2,016)                    | 117 (83-157)  |

**Table 2B: Hospitalisation rates and cost by current CD4 cell count in patients before and after ART initiation after removing events in patients initiating ART at CD4 cell counts > 200 mm<sup>3</sup>**

| CD4 cell count stratum | Total patient years (%) | Number of hospitalisations | Hospitalisation rate per 100 patient years (95% CI) | Mean length of stay [days] (95% CI) | Mean cost per stay [2009 USD] (95% CI) | Mean inpatient cost per patient year in cohort [2009 USD] (95% CI) |
|------------------------|-------------------------|----------------------------|---|-------------------------------------|--|--|
| <b>Both sites</b>      |                         |                            |   |                                     |  |  |
| <b>Pre-ART</b>         |                         |                            |   |                                     |  |  |
| ≤100 cells/microl      | 602.8 (8.6)             | 60                         | 10.0 (7.6-12.8)                                     | 10.4 (7.4-13.4)                     | 1,759 (1,254-2,263)                    | 176 (95-290)   |
| 101-200 cells/microl   | 1,233.9 (17.6)          | 78                         | 6.3 (5.0-7.9)                                       | 8.6 (5.9-11.2)                      | 1,453 (988-1,919)                      | 92 (49-152)  |
| 201-350 cells/microl   | 2,275.6 (32.5)          | 109                        | 4.8 (3.9-5.8)                                       | 8.7 (6.7-10.6)                      | 1,452 (1,126-1,778)                    | 70 (44-103)  |
| >350 cells/microl      | 2,889.5 (41.3)          | 97                         | 3.4 (2.7-4.1)                                       | 7.8 (5.6-10.0)                      | 1,290 (934-1,645)                      | 44 (25-67)   |
| All pre-ART patients   | 7,001.7                 | 344                        | 4.9 (4.4-5.4)                                       | 8.7 (7.5-9.9)                       | 1,460 (1,267-1,657)                    | 72 (56-89)   |
| <b>On ART</b>          |                         |                            |   |                                     |  |  |
| ≤100 cells/microl      | 132.3 (5)               | 27                         | 20.4 (13.5-29.8)                                    | 12.1 (6.6-17.5)                     | 2,042 (1,128-2,957)                    | 417 (152-881)  |
| 101-200 cells/microl   | 441.6 (18)              | 41                         | 9.3 (6.7-12.6)                                      | 14.0 (8.3-19.7)                     | 2,343 (1,387-3,300)                    | 218 (93-416)   |
| 201-350 cells/microl   | 945.2 (40)              | 70                         | 7.4 (5.8-9.4)                                       | 9.6 (7.6-11.6)                      | 1,611 (1,279-1,943)                    | 119 (74-183)   |
| >350 cells/microl      | 910.3 (37)              | 35                         | 3.8 (2.7-5.3)                                       | 6.0 (4.4-7.6)                       | 1,006 (728-1,284)                      | 39 (20-68)   |
| All ART patients       | 2,429.5                 | 173                        | 7.1 (6.2-8.2)                                       | 10.3 (8.5-12.1)                     | 1,730 (1,427-2,032)                    | 123 (88-167)   |

**Table 2C: Hospitalisation rates and cost by current CD4 cell count in patients before and after ART initiation after removing events during the first three months after ART initiation**

| CD4 cell count stratum | Total patient years (%) | Number of hospitalisations | Hospitalisation rate per 100 patient years (95% CI) | Mean length of stay [days] (95% CI) | Mean cost per stay [2009 USD] (95% CI) | Mean inpatient cost per patient year in cohort [2009 USD] (95% CI) |
|------------------------|-------------------------|----------------------------|---|-------------------------------------|--|--|
| <b>Both sites</b>      |                         |                            |   |                                     |  |  |
| <b>Pre-ART</b>         |                         |                            |   |                                     |  |  |
| ≤100 cells/microl      | 603 (9)                 | 60                         | 10.0 (7.6-12.8)                                     | 10.4 (7.4-13.4)                     | 1,759 (1,254-2,263)                    | 176 (95-290)   |
| 101-200 cells/microl   | 1,234 (18)              | 78                         | 6.3 (5.0-7.9)                                       | 8.6 (5.9-11.2)                      | 1,453 (988-1,919)                      | 92 (49-152)  |
| 201-350 cells/microl   | 2,276 (33)              | 109                        | 4.8 (3.9-5.8)                                       | 8.7 (6.7-10.6)                      | 1,452 (1,126-1,778)                    | 70 (44-103)  |
| >350 cells/microl      | 2,890 (41)              | 97                         | 3.4 (2.7-4.1)                                       | 7.8 (5.6-10.0)                      | 1,290 (934-1,645)                      | 44 (25-67)   |
| All pre-ART patients   | 7,001.7                 | 344                        | 4.9 (4.4-5.4)                                       | 8.7 (7.5-9.9)                       | 1,460 (1,267-1,657)                    | 72 (56-89)   |
| <b>On ART</b>          |                         |                            |   |                                     |  |  |
| ≤100 cells/microl      | 137.8 (5)               | 21                         | 15.2 (9.4-23.3)                                     | 11.5 (5.2-17.8)                     | 1,914 (879-2,948)                      | 292 (83-687)   |
| 101-200 cells/microl   | 468.1 (17)              | 25                         | 5.3 (3.5-7.9)                                       | 10.2 (4.6-15.8)                     | 1,694 (768-2,320)                      | 90 (27-183)  |
| 201-350 cells/microl   | 1,048.5 (38)            | 60                         | 5.7 (4.4-7.4)                                       | 9.7 (7.3-12.0)                      | 1,617 (1,230-2,004)                    | 93 (54-148)  |
| >350 cells/microl      | 1,134 (41)              | 39                         | 3.4 (2.4-4.7)                                       | 6.3 (4.6-8.0)                       | 1,055 (763-1,347)                      | 36 (18-63)   |
| All ART patients       | 2,788.4                 | 145                        | 5.2 (4.4-6.1)                                       | 9.1 (7.5-10.8)                      | 1,522 (1,248-1,796)                    | 79 (55-110)  |

## 7 Outpatient cost and outcomes of paediatric antiretroviral treatment in South Africa

### Cost and outcomes of paediatric antiretroviral treatment in South Africa

1. For a 'research paper' already published
  - 1.1. Where was the work published? **AIDS**
  - 1.2. When was the work published? **2012**
  - 1.3. Was the work subject to academic peer review? **Yes**
  - 1.4. Have you retained the copyright for the work? **No**

If yes, attach evidence of retention

If no, or if the work is being included in its published format, attach evidence of permission from copyright holder (publisher or other author) to include work **See exemption on next page**

2. For a 'research paper' prepared for publication but not yet published
  - 2.1. Where is the work intended to be published?
  - 2.2. List the paper's authors in the intended authorship order
  - 2.3. Stage of publication – Not yet submitted/Submitted/Undergoing revision from peer reviewers' comments/In press
3. For multi-authored work, give full details of your role in the research included in the paper and in the preparation of the paper. (Attach a further sheet if necessary)

**The candidate collected all the data, did all the data analysis and wrote the first draft of the publication.**

Candidate's signature

Dr Gesine Meyer-Rath

Supervisor or senior author's signature to confirm role as stated in (3)

Dr Alec Miners

Supervisor



Title: Cost and outcomes of  
paediatric  
antiretroviral  
treatment in South  
Africa

Author: Gesine Meyer-Rath,  
Alana Brennan,  
Lawrence Long, et al

Publication: AIDS

Publisher: Wolters Kluwer  
Health, Inc.

Date: Jan 1, 2013

Copyright © 2013, (C) 2013  
Lippincott Williams

This reuse is free of charge. No permission letter is needed from Wolters Kluwer Health, Lippincott Williams & Wilkins. We require that all authors always include a full acknowledgement. Example: AIDS: 13 November 2013 - Volume 27 - Issue 17 - p 2679-2689. Wolters Kluwer Health Lippincott Williams & Wilkins© No modifications will be permitted.

Copyright © 2015 [Copyright Clearance Center, Inc.](#) All Rights Reserved.  
[Privacy statement.](#) [Terms and Conditions.](#)

Comments? We would like to hear from you. E-mail us at  
[customercare@copyright.com](mailto:customercare@copyright.com)



### ***Preamble for paper 3***

An important requirement of the National ART Cost Model was the inclusion of the cost of both adult and paediatric ART provision. In the few models of ART cost in South Africa in existence before the NACM, paediatric ART provision had received short shrift: In one of the models used previously for budget planning and decision making in South Africa, the Cape Town ARV Costing Model, the cost of paediatric ART had been set equal to that of adult ART, with the exception of ARV drug costs which were set at 1.35 times that of adults, based on an assumption of the authors [1]. In the most recent cost analysis of national HIV policy before the National ART Cost Model, the NSP 2007-2011 Costing Model, paediatric ART was excluded altogether [2].

Anecdotal evidence had long suggested that paediatric ART provision is more resource intensive, especially in terms of the number of visits and clinic staff required, and more costly, in part due to the more complex and expensive paediatric formulations of antiretrovirals, most of which are formulated as syrups for children under the age of five to aid with intake. There had not, however, been a single published analysis of the cost of paediatric ART in a low- or middle-income country. This is in sharp contrast to the magnitude of the burden of disease due to HIV amongst children, the HIV-related mortality in this age group which is much higher than amongst adults, and the fact that at the time of the analysis, ART coverage amongst children in South Africa was only 36% of the eligible population, as opposed to 55% amongst adults [3].

Paper 3 adds to the body of knowledge by providing the first bottom-up analysis of the cost of paediatric ART provision at the outpatient level in sub-Saharan Africa. The analysis was undertaken in two of the largest paediatric ART clinics in South Africa, one in inner-city Johannesburg and one in Soweto, using identical methodology. The analysis also included an evaluation of patient-level outcomes such as retention in care and treatment success and allowed the differentiation of cost by patient outcome (cost per patient in care and responding, cost per patient in care but not responding, cost per patient no longer in care) which in turn meant the cost categories better fitted the model categories of the NACM with regards to types of care.

The analytical framework for the cost-outcomes analysis of paediatric antiretroviral treatment was developed by Sydney Rosen and Lawrence Long. All co-authors contributed comments and helped edit the paper. All other work, including data collection and analysis and writing the first and consecutive drafts of the thesis, was the candidate's.

## **References**

1. Cape Town (CT) ARV Cost Model. School of Public Health and Family Medicine, University of Cape Town/ Department of Health, Provincial Administration of the Western Cape, South Africa. September 2004.
2. Cleary, S. 2007. Costs of the South African National Strategic Plan for HIV and AIDS & STIs 2007-2011. Health Economics Unit, University of Cape Town, Cape Town.
3. World Health Organization. Global HIV/AIDS response: epidemic update and health sector progress towards universal access: Progress report 2011. Geneva, Switzerland: WHO; 2011.

## **Paper 3**

### **Cost and outcomes of paediatric antiretroviral treatment in South Africa**

Gesine Meyer-Rath<sup>1,2</sup>, Alana Brennan<sup>1,2</sup>, Lawrence Long<sup>2</sup>, Buyiswa Ndibongo<sup>2</sup>, Karl Technau<sup>3,4</sup>, Harry Moultrie<sup>3,5</sup>, Lee Fairlie<sup>3,5</sup>, Ashraf Coovadia<sup>3,4</sup>, Sydney Rosen<sup>1,2\*</sup>

<sup>1</sup> Center for Global Health and Development, Boston University, US

<sup>2</sup> Health Economics and Epidemiology Research Office (HE<sup>2</sup>RO), Department of Medicine, Faculty of Health Sciences, University of the Witwatersrand, Johannesburg, South Africa

<sup>3</sup> Department of Paediatrics and Child Health, Faculty of Health Sciences, University of the Witwatersrand, Johannesburg, South Africa

<sup>4</sup> Empilweni Services and Research Unit, Rahima Moosa Mother and Child Hospital, Johannesburg, South Africa

<sup>5</sup> Wits Reproductive Health and HIV Institute, University of the Witwatersrand, Johannesburg, South Africa

\*Corresponding author: Sydney Rosen, Boston University Center for Global Health and Development, 801 Massachusetts Ave, Rm 380, Boston, MA 02118 USA. Tel + 1 617 414 1273. E-mail [sbrosen@bu.edu](mailto:sbrosen@bu.edu).

**Source of Support:** U.S. Agency for International Development

**Potential Conflicts of Interest:** The authors declare that they have no conflicts of interest.

**Previous Presentation of Findings:** Partial results of this study (preliminary data from one study site) were presented in Abstract 685, 18th Conference on Retroviruses and Opportunistic Infections, Boston, February 27-March 2, 2011.

#### **ABSTRACT**

**Objective:** Little is known about the cost of paediatric antiretroviral treatment (ART) in low- and middle-income countries. We analysed the average cost of providing paediatric ART in South Africa during the first two years after ART initiation, stratified by patient outcomes.

**Methods:** We collected data on outpatient resource use and treatment outcomes of 288 children in two Johannesburg public hospitals, Empilweni Services and Research Unit (ESRU) and Harriet Shezi Children's Clinic (HSCC) from 2005 and 2009. Patient-level resource use was estimated from patient records. Unit cost data came from site accounts and public-sector sources. Patient outcomes at month 12 and 24 after initiation were defined based on weights, CD4 cell counts/percentages, viral loads, and the presence of new WHO stage 3/4 conditions.

**Results:** Median age/mean CD4 percentage at initiation were 4.03 years/13.23% in ESRU and 5.84 years/14.61% in HSCC, respectively. 62% and 91% of patients remained in care and responding to treatment at month 12 in ESRU and HSCC, respectively, and 68% and 80% at month 24. The average cost per patient in care and responding was \$830 in year 1 and \$717 in year 2 in ESRU and \$678 and \$782 in HSCC. ARV drugs comprised 33-52% of total cost, clinic visits 23-31%, lab tests 12-16%, and fixed costs 8-18%.

**Conclusions:** Costs varied between the two clinics but were comparable to those of adult ART. Few very young children accessed ART in either clinic and those who did were already very ill, emphasizing the importance of early infant treatment.

**Keywords:** South Africa, paediatrics, antiretroviral therapy, costs, outcomes, cohort studies

## INTRODUCTION

To achieve national and international targets for treatment of paediatric HIV/AIDS, provision of paediatric antiretroviral therapy (ART) must continue to expand in low- and middle-income countries. In South Africa, as in many countries, access to paediatric treatment services has lagged behind that of adult services, with reported coverage of just 36% of the estimated 300,000 South African children eligible for ART in 2010, compared to adult coverage of 55% of the approximately 2.5 million treatment-eligible adults[1]. In response, South Africa's National Strategic Plan for its HIV/AIDS program sets a target of initiating 90% of eligible children on ART and of ensuring that 85% of eligible children remain on treatment by 2016[2].

According to a recent meta-analysis and several cohort studies, children on ART in Africa experience high survival and large improvements in immunological function and growth over the first 1-3 years on ART[3-9]. In a pooled analysis of data from multiple African countries, 82.3% of children remained alive and in care 24 months after treatment initiation[8]. In the Western Cape Province of South Africa, 82% of children remained in care after 3 years, with the proportion of patients with viral suppression estimated at 73-75% and the proportion with CD4 percentages >20% increasing from 58% after 6 months of treatment to 83% after 36 months[9]. In South Africa's Gauteng Province, 83% remained in care after 36 months, and 96.2% of those remaining in care at 24 months were virally suppressed [7].

Encouraging as these findings are, securing the additional funding needed to increase coverage among children, at a time of flat or declining donor budgets, will continue to be a major challenge. Essential to overcoming that challenge will be accurate, policy-relevant information on the actual costs of delivering paediatric ART. There is only one published estimate of the costs of providing paediatric ART in resource-

constrained countries available to policy makers, however, and South Africa is not included in its analysis[10]. Decisions about the scale-up of paediatric ART in South Africa and other countries are thus being made with incomplete information about their consequences. The objective of this study was to estimate and analyze the average cost of providing paediatric ART, stratified by patient outcome. This information will assist local policy makers, private and nongovernmental providers, and funding agencies to understand the factors that influence paediatric ART costs and outcomes, estimate resource needs, and improve the efficiency of the national treatment programme.

## **METHODS**

### **Settings and cohorts**

We collected data on outpatient resource use during the first 24 months after ART initiation at two paediatric ART clinics in Gauteng Province: Empilweni Services and Research Unit (ESRU) of Rahima Moosa Mother and Child Hospital, with data collected for 2005-2009; and Harriet Shezi Children's Clinic (HSCC) at Chris Hani Baragwanath Hospital [7], with data for 2007-2009. The sites were both located in public sector academic hospitals in urban areas, but they differed sharply in scale (patient volume). At ESRU, the number of children on ART increased from 518 to 1,253 over the study years from 2005 to 2009. At HSCC, it grew from 1,617 to 2,434 over the study years from 2007 to 2009. Both sites followed South African guidelines for treatment initiation and ARV regimens[13]. During most the study period, ART initiation criteria included more than two hospitalisations per year or prolonged hospitalisation (>4 weeks) for HIV-related disease; modified WHO Stage 3 or 4 disease; or a CD4 percentage <20% in a child under 18 months old or <15% in a child over 18 months old, both irrespective of disease stage. The recommended paediatric regimens consisted of stavudine, lamivudine, and lopinavir/ ritonavir for children initiated at less than 3 years of age and of stavudine, lamivudine, and efavirenz for children initiated at 3 years or older [13].

We enrolled into the study a consecutive sample of 150 children in each clinic who had initiated ART below the age of 13 years, based on a register of patients in care by March 2008 (ESRU) and January 2009 (HSCC). Patients who had been enrolled in a clinical trial, initiated while admitted in a hospital ward, or transferred out of the clinic during the first two years after treatment initiation were excluded, since the resource use noted in their outpatient files was likely incomplete or, in the case of participation in a clinical trial, not representative of routine care.

Approval for this study was granted by the Human Research Ethics Committee of the University of the Witwatersrand and the Institutional Review Board of Boston University Medical Campus.

### **Resource use and unit cost**

The methods used to analyse the costs and outcomes have been described previously[11]. Patient-level data were collected from patient files. This included the number of patient visits and consultations by type of health worker (doctor, nurse, pharmacist, social worker, counselor, dietician), amount and type of antiretroviral drugs and non-antiretroviral drugs dispensed, and laboratory and other diagnostic or monitoring investigations, including radiograms, electrocardiograms, and ultrasounds. We reviewed clinic and hospital accounts for the number and salaries of staff, the quantities and prices of clinic equipment and supplies, and infrastructure, utilities, clinic administration and management, maintenance, equipment and supplies, and security costs. Drug unit cost data were collected from the nearest government drug depot and laboratory costs from the National Health Laboratory Service. All other unit costs came from financial records or interviews with administrative staff.

Fixed costs, including the cost of staff who do not provide direct patient care, building, equipment and supplies, were summed per year and divided by the total number of patient-months of care provided in that year to generate an average fixed cost per patient-month of care. This amount was then allocated to each study subject per month the subject remained in care. Buildings were valued based on market rental rates for similar structures in the neighbourhoods surrounding the sites; equipment was depreciated according to standard South African accounting practices[12]. Costs for resources not reported in site medical records, such as inpatient care, costs above the level of the treatment facility (e.g. government costs of oversight and training), and costs to the patients themselves were excluded from the analysis.

Resource usage was analysed from the provider perspective. Cost data were from 2009 and were converted to US dollars at a rate of USD 1 = ZAR 8.28, the average exchange rate for 2009. Data were collected using CPro version 3.3 and analysed in SAS version 9.1.

### **Outcome status**

Using a paediatric adaptation of a previously published methodology[11], each subject was assigned to a single outcome on the basis of vital status, attendance status, laboratory results, or the presence of a new or recurring WHO stage 3 or 4 event 12 months and 24 months after initiating ART. The criteria for defining the outcomes, which were mutually exclusive, were assigned using a hierarchical decision process that takes into account the variability and timing of available information (Table 1). To cope with inconsistent timing of visits and laboratory tests, information reported in the subject's medical record within 3 months on either side of the 12- and the 24-month endpoint was used to assign an outcome.

**Table 1: Definitions of treatment outcomes**

| <b>Outcome</b>             | <b>Criteria for assigning outcome</b>        | <b>Definitions of criteria</b>  | <b>Medical record data required to use each criterion</b>  |
|----------------------------|--|---|--|
| Excluded from study        | Transferred                                  | Transferred to another treatment site   | Record notation of transfer in month 0-24  |
|                            | Never started ART                            | Never collected first month's supply of ARVs  | No medication pickup recorded in month 0-24  |
| No longer in care          | Died   | Died  | Confirmation of death in month 0-12/ 0-24 by record notation or death certificate  |
|                            | Stopped attending clinic (lost to follow up) | ≥3 months late for last scheduled consultation or medication pickup   | Date of last scheduled consultation or medication pickup   |
| In care but not responding | Unacceptable clinical condition              | Weight gain ≤ 0 or new or recurrent WHO stage 3 or 4 event at most recent visit (excluding irreversible conditions) | Clinic visit closest to month 12/24 within 9-15/ 21-27 month window  |
|                            | Detectable viral load                        | Viral load > lowest detectable level of test used   | Viral load test closest to month 12/24 within 9-15/ 21-27 month window; assumes no unacceptable clinical condition.                  |
|                            | Unacceptable CD4% or count                   |   | CD4 count or percentage at baseline and closest to month 12/24 within 9-15/ 21-27 month window; assumes no viral load test available |
|                            | Age 24-35 months                             | CD4% < 20% <u>or</u> < baseline value   |  |
|                            | Age 35-59 months                             | CD4% < 15% <u>or</u> < baseline value   |  |
|                            | Age >59 months                               | CD4% < 15% <u>or</u> < baseline value; or CD4 count < 200 <u>or</u> < baseline value                                |  |
| In care and responding     | Undetectable viral load                      | Viral load ≤ lowest detectable level of test used.  | Viral load test closest to month 12/24 within 9-15/ 21-27 month window   |
|                            | Acceptable CD4% or count                     |   | CD4 count or percentage at baseline and closest to month 12/24 within 9-15/ 21-27 month window; assumes no viral load test available |
|                            | Age 24-35 months                             | CD4% > 20% <u>and</u> > baseline value  |  |
|                            | Age 35-59 months                             | CD4% > 15% <u>and</u> > baseline value  |  |
|                            | Age >59 months                               | CD4% > 15% <u>and</u> > baseline value; or CD4 count > 200 <u>and</u> > baseline value                              |  |
|                            | Acceptable clinical condition                | No new or recurrent WHO stage 3 or 4 event at most recent visit (excluding irreversible conditions)                 | Clinic visit closest to month 12/24 within 9-15/21-27 month window; assumes no viral load test or CD4% or count available            |

Subjects who died or stopped attending the study clinic during the 12- or 24-month period were classified as “no longer in care.” “Stopped attending” was defined as not having returned for a scheduled visit during the three months before the end of the 12- or 24-month period. If no next visit date had been scheduled, subjects were classified as “stopped attending” if they did not have a visit for at least four months before the end of the 12- or 24-month window.

Among those still in care, any subject having a new or recurrent WHO stage 3 or 4 event at most recent visit (excluding irreversible conditions) or whose most recent weight was the same or had dropped below the weight at initiation was considered “in care but not responding.” For those who remained in care and did not meet these event or weight criteria, viral load and CD4 cell counts or percentages (depending on

age) were considered for those whom these test results were available. Subjects whose medical record reported a detectable viral load, defined as >400 copies/mL, at 9-15 or 21-27 months after ART initiation were classified as “in care but not responding”; those whose viral load was undetectable were classified as “in care and responding.” For subjects for whom no viral load test was reported, a CD4 percentage or cell count in month 9-15 or 21-27 was used. Subjects whose CD4 percentage or cell count showed an increase from baseline were defined as in care and responding. If neither viral load nor CD4 results were reported in month 9-15 or 21-27, but the child remained in care and did not have a current WHO Stage 3 or 4 event and the most recent weight, where available, was above the weight at initiation, a default outcome of in care and responding was assigned.

### **Cost per patient**

For each patient outcome and site, the mean and median cost per patient for the first and second years after treatment initiation were calculated. For purposes of the cost analysis, 24-month outcomes were used for patients whose outcomes changed between 12 and 24 months. We evaluated the breakdown of average cost per patient among the main resources used (drugs, lab tests, clinic visits, fixed costs) and considered changes between the first and second years after initiation. Finally, the mean cost to produce a patient in care and responding at 12 months after ART initiation was calculated by dividing all costs for all the patients in the sample by the number of patients in care and responding at 12 months, and a similar calculation was performed for 24 months using 24-month outcomes and total costs.

## **RESULTS**

### **Characteristics of study samples**

Characteristics of study subjects at treatment initiation are described in Table 2. After enrolment, 12 children at HSCC were found to have been initiated while admitted for inpatient care and were subsequently excluded from the study, producing a final sample size of 138 at HSCC and 150 at ESRU.

Patients at HSCC were on average older at initiation than those at ESRU and had slightly (though not significantly) higher starting CD4 percentages. In part as a consequence of the older cohort, HSCC was more likely to have used EFV, rather than LPV/r, in its starting ARV regimen. No patient at either site was prescribed second-line regimens containing didanosine during the first two years after treatment initiation.



**Table 2. Characteristics of study samples at treatment initiation**

| Characteristic   | ESRU               | HSCC               |
|--|--------------------|--------------------|
| n  | 150                | 138                |
| Median age at initiation in years (inter-quartile range) | 4.03 (1.61-7.19)   | 5.84 (2.88-8.21)   |
| Median CD4% at initiation (inter-quartile range)         | 12.40 (7.09-17.75) | 14.05 (8.69-19.80) |
| ARV regimens (% of all patient-months in care)           |                    |                    |
| Year 1   |                    |                    |
| d4T/ 3TC/ EFV  | 56                 | 71                 |
| d4T/ 3TC/ LPV/r  | 31                 | 23                 |
| ABC/ 3TC/ EFV or LPV/r                                   | 1                  | 2                  |
| any second line  | 0                  | 0                  |
| other  | 12                 | 4                  |
| Year 2   |                    |                    |
| d4T/ 3TC/ EFV  | 51                 | 68                 |
| d4T/ 3TC/ LPV/r  | 32                 | 24                 |
| ABC/ 3TC/ EFV or LPV/r                                   | 4                  | 4                  |
| any second line  | 0                  | 0                  |
| other  | 13                 | 4                  |

**Outcomes**

The percentage of children with each outcome and the indicators used to assign the outcomes are shown in Table 3. As noted above, outcomes were assigned solely on the basis of information available in existing medical records. For Year 1 at ESRU, for example, 30% of patients were categorized as in care and responding on the basis of an undetectable viral load, but only 9% were categorized as in care but not responding due to a detectable viral load. This simply indicates that only 39% of patients in the sample remained in care, did not have an unacceptable clinical condition, and did have viral load results reported in the relevant time period (9-15 months after ART initiation), following the definitions in Table 1. Patients who were in fact virally suppressed at 12 months but did not have a viral load result reported in their records could not be assigned an outcome on this basis. Except for any who had an insufficient CD4 cell response, these patients would still have been categorized as in care and responding, but their outcome would have been assigned by default (not meeting the criteria for any other outcome), rather than as a result of a viral load result.

**Table 3: Outcomes for year 1 and year 2 after treatment initiation**

| Outcomes   | ESRU   |      |        |      | HSCC   |      |        |      |
|--|--------|------|--------|------|--------|------|--------|------|
|  | Year 1 |      | Year 2 |      | Year 1 |      | Year 2 |      |
|  | n      | %    | n      | %    | n      | %    | n      | %    |
| Total number of subjects enrolled (n)                | 150    | 100% | 150    | 100% | 138    | 100% | 138    | 100% |
| Categorised as in care and responding, based on:     |        |      |        |      |        |      |        |      |
| Undetectable viral load                              | 45     | 30%  | 45     | 30%  | 17     | 12%  | 35     | 25%  |
| Acceptable CD4 change                                | 4      | 3%   | 1      | 1%   | 4      | 3%   | 4      | 3%   |
| No new WHO Stage 3/4 condition                       | 44     | 29%  | 56     | 37%  | 104    | 75%  | 71     | 51%  |
| Total in care and responding                         | 93     | 62%  | 102    | 68%  | 125    | 91%  | 110    | 80%  |
| Categorised as in care but not responding, based on: |        |      |        |      |        |      |        |      |
| New WHO Stage 3/4 condition                          | 1      | 1%   | 0      | 0%   | 0      | 0%   | 1      | 1%   |
| Weight gain <=0                                      | 0      | 0%   | 0      | 0%   | 0      | 0%   | 0      | 0%   |
| Detectable viral load                                | 14     | 9%   | 6      | 4%   | 4      | 3%   | 12     | 9%   |
| Unacceptable CD4 change                              | 6      | 4%   | 1      | 1%   | 2      | 1%   | 6      | 4%   |
| Total in care but not responding                     | 21     | 14%  | 7      | 5%   | 6      | 4%   | 19     | 14%  |
| Categorised as no longer in care, based on:          |        |      |        |      |        |      |        |      |
| Died   | 7      | 5%   | 7      | 5%   | 2      | 1%   | 3      | 2%   |
| Stopped attending site (lost to follow up)           | 29     | 19%  | 34     | 23%  | 5      | 4%   | 5      | 4%   |
| Total no longer in care                              | 36     | 24%  | 41     | 27%  | 7      | 5%   | 8      | 6%   |

Patients in the cohort at HSCC did better throughout the study period, with 91% of patients in year 1 and 80% in year 2 in care and responding to treatment. At ESRU, only 62% of patients were classified as in care and responding at the end of year 1 and 68% at the end of year 2, with a much higher percentage no longer in care than in HSCC (24% and 27% vs. 5% and 6% at 12 and 24 months, respectively).

Importantly, at ESRU two thirds of the children with a 12-month in care but not responding outcome recovered during the second year on treatment. The 12-month in care but not responding outcomes were mostly due to intermittent increases in viral loads and resulting unacceptably low CD4 cell counts/percentages which later subsided without necessitating a switch of regimens, resulting in an in care and responding result at 24 months. This did not occur at HSCC, where several children developed newly detectable viral loads between 12 and 24 months on treatment.

### Resource utilisation and costs

The top panel of Table 4 describes average resource utilisation per year in care for each study site. Across both study sites and years after ART initiation we estimated an average cost per patient-year in care of \$693, regardless of outcome. As reported in the lower panel of Table 4, the average cost per patient remaining in care and responding at 24 months was \$826 in year 1 and \$717 in year 2 at ESRU, and \$678 and \$782 in years 1 and 2, respectively, at HSCC. At ESRU the second year on treatment was slightly less expensive for all outcome categories, due mainly to fewer visits to all types of staff and a halving of fixed costs by the second year as result of increasing facility scale. Average fixed costs per patient-month in care fell in the second year as a result of a steady increase in patient numbers at ESRU over the course of the study period, such that each study subject's second year reflected economies of

scale relative to the same subject's first year. In contrast, at HSCC the second year on treatment was more expensive across all outcome categories, largely as a result of a doubling of the staff contingent in 2008, which coincided with the second year on treatment for most patients in our cohort, to compensate for past under-staffing and prepare for an anticipated future increase in patient numbers. The cost of the ARV medications comprised a third to a half of total cost, with higher ARV costs at ESRU where patients were younger at initiation and thus more likely to be treated with LPV/r than at HSCC. At both sites, patients made substantially more clinic visits in the first year after treatment initiation than in the second, reflecting the need for more frequent monitoring in the period immediately after initiation. By the second year, most patients who are still in care have stabilised and require less frequent clinical monitoring.

The average cost per patient initiated on treatment, as shown in Table 4, is substantially lower than the cost per patient with an in care and responding outcome, due to the large number of patients who did not remain in care for the full 12 or 24 months. If outcomes improve, the total cost of treatment each hospital's population of paediatric patients will thus increase from current expenditure levels. The total cost of producing a patient in care and responding to treatment was \$1,117 and \$829 in years 1 and 2 in ESRU, respectively, and \$819 and \$937 in HSCC. This measure, which allows us to summarise cost and outcomes of each clinic in a single metric, divides the total cost accrued by each clinic cohort by the number of in care and responding patients produced by each clinic. Because the patients in our sample in ESRU had better outcomes in year 2 than in year 1, the production cost decreased by 26% during the second year, while in HSCC it increased by 14%, mostly due to the increase in staff cost that was not offset by changes in patient outcomes.

**Table 4: Resource utilisation and cost per 24-month outcome and distribution of cost by item for year 1 and year 2 after treatment initiation, by clinic**

|   | ESRU        |           | HSCC       |            | Both sites and years | For comparison: Adult clinic (based on [11]) |
|---|-------------|-----------|------------|------------|----------------------|--|
|   | Year 1      | Year 2    | Year 1     | Year 2     |                      | Year 1                                       |
| Average resource utilisation per patient-year in care                                       |             |           |            |            |                      |  |
| CD4 cell counts/percentage tests  | 1.74        | 0.82      | 1.60       | 1.69       | 1.48                 | 2.7  |
| Viral load tests  | 2.30        | 0.87      | 1.59       | 1.70       | 1.63                 | 1.4  |
| Visits per year to the following type of staff:   |             |           |            |            |                      |  |
| Doctor  | 7.87        | 4.98      | 7.07       | 4.92       | 6.25                 | 6.1  |
| Nurse   | 7.49        | 4.81      | 7.08       | 6.38       | 6.49                 | 6.1  |
| Pharmacist  | 7.37        | 4.87      | 7.07       | 6.39       | 6.47                 | 9.0  |
| Dietician   | 1.69        | 0.49      | 1.20       | 0.49       | 0.98                 | no data                                      |
| Social worker   | 0.13        | 0.01      | 0.20       | 0.08       | 0.11                 | no data                                      |
| Counsellor  | 7.50        | 4.81      | 6.76       | 4.77       | 5.99                 | no data                                      |
| Physiotherapist <sup>1</sup>  | no data     | no data   | 0.22       | 0.10       | 0.16                 | no data                                      |
| Average staff cost/ doctor visit [2009 USD]   | 32.50       | 32.83     | 18.77      | 31.58      | 28.76                | 18.28  |
| Fixed costs/ patient month in care [2009 USD]   | 9.01        | 8.46      | 10.15      | 11.95      | 9.94                 | 6.85   |
| Mean cost per 24-month outcome [2009 USD] (standard deviation)                              |             |           |            |            |                      |  |
| In care and responding  | 830 (274)   | 717 (28)  | 678 (177)* | 782 (177)  | 752                  | 802 (388)                                    |
| In care but not responding  | 1,080 (324) | 773 (461) | 625 (139)* | 748 (157)  | 806                  | 803 (123)                                    |
| No longer in care   | 478 (286)   | 163 (303) | 355 (326)  | 281 (460)  | 324                  | 403 (302)                                    |
| All subjects in sample  | 746 (327)   | 616 (426) | 653 (197)* | 748 (229)* | 693                  | 674  |
| All subjects remaining in care  | 846 (283)   | 786 (331) | 670 (173)* | 776 (174)  | 769                  | 802  |
| Distribution of annual cost per patient in care and responding [2009 USD] (% of total cost) |             |           |            |            |                      |  |
| ARV drugs   | 343 (41)    | 375 (52)  | 226 (33)   | 274 (35)   | 302 (40)             | 326 (41)                                     |
| Non-ARV drugs   | 23 (3)      | 28 (4)    | 19 (3)     | 21 (3)     | 23 (3)               | 13 (2)                                       |
| Diagnostic tests  | 103 (12)    | 88 (12)   | 105 (16)   | 106 (13)   | 101 (13)             | 146 (18)                                     |
| Clinic visits   | 255 (31)    | 168 (23)  | 207 (31)   | 242 (31)   | 219 (31)             | 165 (21)                                     |
| Fixed costs   | 106 (13)    | 58 (8)    | 120 (18)   | 139 (18)   | 107 (18)             | 132 (16)                                     |
| Total   | 830 (100)   | 717 (100) | 678 (100)  | 782 (100)  | 752 (100)            | 802 (100)                                    |

<sup>1</sup> Physiotherapist visits are not included in the estimation of cost, since only one clinic (HSCC) had full records of these visits.

\* Difference from ESRU significant at 5% level using t-test for the means of two samples. The same levels were obtained using Wilcoxon sum-rank test assuming a non-normal (t) approximation for the medians of two samples.

### Comparison with cost of adult ART

At a public sector, hospital-based adult ART clinic in the same province of South Africa, located just 2 km from one of the paediatric sites, average costs for adult patients remaining in care (responding or not) in 2009 USD were \$802 for year 1 and \$795 for year 2, or a total of \$1,597 for the two-year period (based on [11], updated to 2009 unit costs) (see Table 4). Paediatric treatment at our study sites was thus less expensive than adult treatment at a comparable site.

## DISCUSSION

South Africa's public sector began to offer ART to HIV-infected children in South Africa nearly a decade ago and had some 152,000 children on treatment by mid-2011[14], representing fully a third of all paediatric ART patients in low and middle income countries [1]. Despite this, there are still no empirical estimates available of the actual cost of providing paediatric ART at typical treatment delivery sites in the country. In this paper, we report the average cost per child initiated on ART and per outcome achieved during the first two years after treatment initiation for two large paediatric ART clinics in Gauteng Province, where around 22% of the paediatric ART population is cared for. Our results will assist program managers, policy makers, and funding agencies to improve the accuracy of their planning and budgeting, as well as helping paediatric clinics understand and improve the quality of care they provide.

We found that two years after treatment initiation, 83% of children in the overall study sample remained in care and 76% were classified as in care and responding to treatment. These outcomes are consistent with previous studies' findings for paediatric cohorts in South Africa. At comparable adult clinics in South Africa, studies using identical methodology have estimated rates of retention in care at 12 months of 71%[11]. The aggregate 12-month retention rate for children in this study, 85%, suggests that paediatric clinics are achieving outcomes comparable to or better than adult clinics. There was variation between our two study clinics, however. In ESRU, the proportion who died or were lost to follow-up was substantial in year 1 and rose modestly in year 2, and the proportion in care but not responding fell in year 2. Seventy-three percent of patients ended the study period in care and responding. In HSCC, the proportions of patients no longer in care and in care but not responding were much lower throughout, with a small increase in these outcomes between year 1 and year 2.

Across both of our study sites and years after ART initiation, without regard to outcome, we estimated an average cost per patient-year in care of \$693. While costs did vary by site and year, the average over the 24-month period for patients remaining in care and thus having complete follow-up differed by less than 6%, at \$1,547 for the two-year period in ESRU and \$1,460 in HSCC. The costs we estimated for paediatric treatment were slightly less than the cost of adult treatment at a nearby facility. The only published study of paediatric and adult ART costs, which considered three African countries but not South Africa, reported that paediatric treatment was considerably more expensive than adult treatment in Ethiopia and Nigeria, but cost much less than adult treatment in Uganda[10]. In that study, cost differences between adult and paediatric treatment nearly vanish when ARV drug procurement is excluded, suggesting that ARV drug costs are the most important driver of the total cost of treatment. Our findings are also explained in part by differences in ARV drug costs. In our study, one of the reasons for the modest cost of paediatric ART may be the lower cost of paediatric antiretroviral regimens (except for those containing LPV/r) when compared to adult regimens.

Our study had a number of limitations. First, the study includes only two sites, both of which are paediatric ART clinics based at large, urban, academic hospitals in Gauteng Province. They may thus not be representative of the costs or outcomes to be expected at smaller sites, primary health care clinics, or other provinces or settings. Second, findings are based on relatively small sample sizes at each site, resulting in large standard deviations for average cost estimates for the smaller outcome categories. Third, results represent average, not marginal, costs and may therefore not reflect the cost of further program expansion. Fourth, inpatient costs were not included, because ART clinic records do not report inpatient care. Previous work by the study team at ESRU suggests that inpatient care may comprise an important share of the total cost of providing HIV care to children[15], though the relative contributions of inpatient and outpatient care to total cost are unknown and may as much depend on the accessibility of paediatric inpatient facilities as on actual need for inpatient care. Children who transferred to another treatment facility during the first 24 months after treatment initiation or who initiated ART while admitted for inpatient care were also excluded and may have differed in costs or outcomes from our study sample. Lastly, and importantly, the patients included in this study initiated ART between 2005 and 2008, which is prior to the adoption of early infant diagnosis and treatment strategies in South Africa. The fact that few very young children or infants were enrolled into this study is a result of this and could potentially alter average cost in the future.

Despite these limitations, this study offers policy makers and funding agencies the first empirical estimates of the actual cost of providing HIV/AIDS treatment to children in South Africa. Costs in the two clinics were comparable both to each other and to those of adult ART. This is of importance for future policy development and counters the assumption that paediatric ART provision will be substantially more expensive than adult ART due to the different drug formulations and higher potential staff and time needs. We did not see evidence of either in our study. The advanced age (4-6 years) and low CD4 percentage (13-14%) at initiation, however, suggests that few very young children accessed ART in either clinic between 2005 and 2008 and that those who did were already very ill. Implementing the new WHO guidelines for paediatric ART[16], already part of South Africa's new National Strategic Plan for HIV[2], is thus a high priority.

**Author contributions:** GMR, LL and SBR designed the study. GMR wrote the first draft of the paper. AB, BN, KT, HM, LF and AC contributed data and analysis. AB, LL and SBR contributed data interpretation. All authors helped draft and revise the article and read and approved the final text.

**Acknowledgements:** The authors thank all patients contributing data to this analysis as well as staff at both clinics and hospitals dedicating time and effort to the data collection, in particular Annie Jordaan, Vincent Kgagkadi, Shobna Sawry and Languta Sibiya. We are grateful to Busisiwe Sithole who provided an outstanding effort in collecting patient-level data. Funding for this study was provided by the United

States Agency for International Development (USAID) under Award 674-A-00-09-00018-00 to Boston University. The funder had no role in study design, data collection or analysis, decision to publish, or preparation of the manuscript. All opinions expressed herein are those of the authors and do not necessarily represent the views of the funder or study sites.

## References

1. World Health Organization. Global HIV/AIDS response: epidemic update and health sector progress towards universal access. Progress report 2011. World Health Organization: Geneva, 2011.
2. Department of Health, Republic of South Africa. National Strategic Plan for HIV/AIDS, Tuberculosis and STIs 2011-2016. Department of Health: Pretoria, 2011.
3. Ciaranello AL, Chang Y, Margulis AV, Bernstein A, Bassett IV, Losina E, Walensky RP. Effectiveness of paediatric antiretroviral therapy in resource-limited settings: a systematic review and meta-analysis. *Clin Infect Dis* 2009; 49:1915–27.
4. Bock P, Boulle A, White C, Osler M, Eley B. Provision of antiretroviral therapy to children within the public sector of South Africa. *Trans Roy Soc Trop Med Hyg* 2008;102:905-11.
5. Reddi A, Leeper SC, Grobler AC, Geddes R, France KH, Dorse GL et al. Preliminary outcomes of a paediatric highly active antiretroviral therapy cohort from KwaZulu-Natal, South Africa. *BMC Pediatr* 2007;7:13.
6. Eley BS, Nuttall J, Davis MA, Smith L, Cowburn C, Buys H et al. Initial experience of a public sector antiretroviral treatment programme for HIV-infected children in Cape Town, South Africa. Abstract TuPeB4412, XVth International AIDS Conference, Bangkok, Thailand, July 11-16, 2004.
7. Meyers T, Yotebing M, Kuhn L, Moultrie H. Antiretroviral therapy responses among children attending a large public clinic in Soweto, South Africa. *Pediatric Infectious Disease Journal* 2011; 30: 974-9.
8. KIDS-ART-LINC Collaboration. Low risk of death, but substantial program attrition, in paediatric HIV treatment cohorts in Sub-Saharan Africa. *J Acquir Imm Defic Syndr* 2008;49:523-31
9. Boulle A, Bock P, Osler M, Cohen K, Channing L, et al. Antiretroviral therapy and early mortality in South Africa. *Bull WHO* 2008;86:678-87.
10. Menzies NA, Berruti AA, Berzon R, Filler S, et al. The cost of providing comprehensive HIV treatment in PEPFAR-supported programs. *AIDS* 2011;25:1753-60.
11. Rosen S, Long L, Sanne I. The outcomes and outpatient costs of different models of antiretroviral treatment delivery in South Africa. *Trop Med Int Health* 2008;13:1005-1015.
12. Accounting Standards Board South Africa. Standard of Generally Recognised Accounting Practice: Property Plant and Equipment (GRAP 176). November 2004.
13. National Department of Health South Africa. National Antiretroviral Treatment Guidelines 2004. Department of Health: Pretoria, 2004.
14. Johnson LF. Access to antiretroviral treatment in South Africa, 2004 - 2011. *Southern African Journal of HIV Medicine* 2012;13(1);22-27.
15. Meyer-Rath G, Violari A, Cotton M, Ndibongo B, Brennan A, Long L, Panchia R, Coovadia A, Gibb DM, Rosen S. The cost of early vs. deferred paediatric antiretroviral treatment in South Africa – A comparative economic analysis of the first year of the CHER trial. Abstract no. THLB103, XVIII International AIDS Conference 2010.
16. World Health Organization. Antiretroviral therapy for HIV infection in infants and children: Towards universal access. Recommendations for a public health approach. 2010 revision. World Health Organization: Geneva, 2010.

## **8 Outpatient and inpatient cost of early vs. deferred paediatric treatment**

### **8.1 Background**

Across the globe, the roll-out of paediatric antiretroviral therapy (ART) in low- and middle-income countries has lagged behind that of adult ART, despite the fact that children and in particular infants have the highest risk of dying from HIV. Without treatment, one third of children infected with HIV during pregnancy or birth die before they turn one; 50% die before they turn two. The reasons for low coverage of paediatric ART are manifold and range from the lack of drug formulations appropriate to children and their life circumstances, the delay in training health personnel to test for HIV and administer ART to children, and the slow roll-out of PCR-based diagnostic tests allowing for early diagnosis [1].

In 2007, the Children with HIV Early Antiretroviral Therapy (CHER) randomised clinical trial conducted in two centres in South Africa established the effectiveness of early antiretroviral treatment (initiation at 6-12 weeks of age) in asymptomatic HIV-infected infants with a CD4 percentage above 25% over treatment initiation under the 2006 WHO paediatric treatment guidelines that deferred treatment initiation until their CD4% fell below 25% or clinical criteria were met (CDC stage C or severe stage B) (hazard ratio for death: 0.24 (95% CI 0.11 to 0.51;  $p < 0.001$ ); hazard ratio for disease progression: 0.25 (95% CI 0.15 to 0.41;  $p < 0.001$ ) [2]. In the deferred treatment arm, treatment was initiated in 66% of infants after a median follow-up of 40 weeks, 26% progressed to CDC stage C or severe stage B disease, compared to 6% in the early treatment arm, and 16% of infants died, compared to 4% in the early treatment arm [2]. After data review, all children in the deferred treatment arm were re-assessed for early initiation of treatment [2]. In a follow-up analysis of the trial data after a median follow-up of 4.8 years, early ART still had better outcomes than deferred ART even if this early treatment was later interrupted [3].

Following this, the World Health Organization in 2010 published a three-fold recommendation: a) to ascertain the exposure status of all children with unknown or uncertain HIV exposure around the time of birth; b) to test all children known to be exposed for HIV at 4-6 weeks with virological assays (i.e., PCR either from blood or dried-blood spots), and c) to initiate all children diagnosed in the first year of life on ART immediately after diagnosis [4,5]. Implementation of these guidelines has been hampered by a number of concerns including an apprehension about the cost of early paediatric treatment (EPT) as compared with paediatric treatment initiated later in a child's life and the affordability of full coverage with paediatric treatment.

We compared the cost of treatment initiation at 6-12 weeks with the cost of initiation based on CD4% threshold or clinical criteria according to 2004 WHO guidelines in trial conditions from the provider



perspective, with the aim of analysing whether the additional resource use in terms of antiretroviral drug provision due to earlier treatment initiation would outweigh the savings from reduced resource use in other care, including inpatient and outpatient care for opportunistic infections. For comparison we then added information on the cost of care for HIV-positive children under the age of 1 in a routine, non-trial setting.

## **8.2 Methods**

### **8.2.1 Cohorts**

We collected data on the outpatient and inpatient resource use during the first 12 months of life in 373 children randomised to either early ART initiation (arms 2/3 combined, n=284) or deferred ART initiation (arm 1, n=89) in the CHER trial, a phase 3 randomised open-label trial conducted at paediatric ART clinics maintained by the Perinatal HIV Research Unit, Chris Hani Baragwanath Hospital, in Soweto, and the Children's Infectious Diseases Clinical Research Unit, Tygerberg Children's Hospital, in Cape Town. All children were enrolled between the ages of 6 and 12 weeks of treatment and had to have a CD4% of 25% or more. First-line treatment consisted of ZDV and 3TC and LPV/r twice daily; second-line treatment of ddl, ABC and NVP. Children were recruited through PMTCT clinics in both hospitals and seen every four weeks until 24 weeks, then every 8 weeks until 48 weeks of age, and 12-weekly thereafter.

### **8.2.2 Resource use and cost data**

We analysed the cost of HIV-related care during the first year of life of two cohorts of HIV-positive children from the provider perspective. Patient-level resource use data were collected from patient files and contained the number of consultations within the clinics, the amount and type of antiretroviral and other drugs dispensed, laboratory tests, and the number of inpatient days. We reviewed clinic and hospital accounts for the number, level, and salaries (including benefits) of staff, the quantities and prices of clinic equipment and supplies, and overheads including utilities, maintenance, and security costs. Drug unit cost data was collected from the nearest drug depot; laboratory costs from the South African national laboratory service. Since no information on resource use during hospital admissions was available for the trial cohorts, apart from information on the dates of admission and discharge, and a common unit cost across both trial sites was necessary, we estimated the cost of inpatient care using information on the length of stay for each admission from the files and the cost per patient-day equivalent (PDE) of a representative children's hospital in the vicinity of one of the clinics, Rahima Moosa Mother and Child Hospital. Cost per PDE is a measurement of average inpatient cost per patient day and is collected routinely by all public-sector hospitals in South Africa.

All cost data was adjusted to 2009 prices and converted to USD using the 2009 average exchange rate of 1 USD = 8.28 ZAR. Data were collected using CSPro version 3.3 and analysed in SAS version 9.1.

## 8.3 Results

### 8.3.1 Cohort characteristics

Even though mean age at study enrolment and mean follow-up time was very similar between the two cohorts (Table 2), mean age at ART initiation was 10 weeks for the early treatment cohort (CHER trial arm 2 and 3) and 20 weeks for the deferred treatment cohort (CHER trial arm 1), due to the deferred nature of treatment initiation in the latter cohort [2]. Early Paediatric Treatment in a group of children diagnosed in the first weeks of life could thus halve the time to ART initiation compared to initiation according to criteria set out in the 2006 WHO paediatric treatment guidelines.

**Table 2: Demographic and treatment characteristics of the two CHER trial cohorts**

|   | Early treatment<br>(CHER trial arm 2 and 3) | Deferred treatment<br>(CHER trial arm 1) |
|---|---|--|
| Sample size   | 284   | 89                                       |
| Mean age at study enrolment in weeks (median, IQR <sup>9</sup> )      | 7.88 (7.57, 6.57-8.86)                      | 7.78 (7.14, 6.43-8.86)                   |
| Mean follow-up time on treatment in weeks (median, IQR <sup>9</sup> ) | 39.09 (41.43, 40.71-41.71)                  | 39.55 (41.86, 40.14-41.57)               |

### 8.3.2 Resource use

Resource use in children in both arms was high, in part due to the more frequent clinic visits and additional laboratory test dictated by the trial protocol. Children in the deferred treatment cohort had on average more clinic visits and more than twice as many inpatient days, compared to the early treatment cohort (Table 3). They also used much higher volumes of antiretroviral drugs, and slightly higher doses of non-antiretroviral drugs prescribed at the outpatient level, most often for the treatment (or prevention) of opportunistic infections. These higher volumes, especially of the antiretroviral drugs, are in large parts due to the comparative older age at initiation of the cohort.

<sup>9</sup> IQR: inter-quartile range

**Table 3: Average resource use per child in the first year of life in the two CHER trial cohorts**

|  | Early treatment<br>(CHER trial arm 2 and 3) | Deferred treatment<br>(CHER trial arm 1) |
|--|---|--|
| <b>Services</b>  |   |  |
| Clinic visits  | 12  | 16                                       |
| Inpatient days   | 1.8   | 6.5                                      |
| <b>Laboratory tests</b>                                      |   |  |
| CD4 tests  | 5   | 7  |
| HIV viral load tests   | 1   | 1  |
| Full blood counts  | 5   | 7  |
| Liver function tests   | 4   | 6  |
| <b>Antiretroviral drugs</b>                                  |   |  |
| AZT syrup (200 ml; 50 mg/ml)                                 | 19  | 70                                       |
| d4T powder for oral solution (200 ml; 1 mg/ml)               | 0.37  | 0  |
| 3TC oral solution (240 ml; 10 mg/ml)                         | 6   | 17                                       |
| LPV/r oral solution (60 ml; 80 mg + 20 mg/ml)                | 8   | 14                                       |
| ABC oral solution (240 ml; 20 mg/ml)                         | 0.01  | 0  |
| <b>Other drugs<sup>10</sup></b>                              |   |  |
| Amoxicillin powder for syrup (125 mg/ml)                     | 0.9   | 1.7                                      |
| Aqueous cream (500 g)  | 0.4   | 0.7                                      |
| Amoxicillin and clavulanate suspension (250 mg + 125 mg/ ml) | 0.6   | 1.7                                      |
| Betamethasone valerate ointment (15 g)                       | 0.2   | 0.5                                      |
| Cotrimoxazole oral solution (100 ml)                         | 1.1   | 1  |
| Miconazole oral gel (30 g; 2%)                               | 0.5   | 1  |
| Hydrocortisone cream (20 g; 1%)                              | 0.6   | 0.8                                      |
| Mycostatin ointment (15 g)                                   | 0.7   | 1.2                                      |
| Paracetamol syrup (100 ml; 120 mg/ 5ml)                      | 2.1   | 3.7                                      |

### 8.3.3 Average cost per child

The mean cost for the first year of life per child in deferred ART was USD 2,432 (95% CI 1,982-2,889), significantly more expensive than the mean cost per child of early ART (USD 1,349, 95% CI 1,244-1,464) (Table 4). In the deferred ART cohort, more than half (51%) of the cost in the first year of life was due to inpatient care, 30% due to staff and overhead costs, 14% due to laboratory costs, and 5% due to drug cost (Table 4). In the early treatment cohort, only 26% of the cost was due to inpatient care, 38% due to staff and overhead costs, and 18% each due to drug costs and to laboratory costs. The per-patient cost of inpatient care in the early arm (USD 346) was less than a third of the inpatient cost in the deferred arm (USD 1,237).

<sup>10</sup> Only the 9 most commonly prescribed drugs are summarised here; a total of 24 different drugs were prescribed at the outpatient level during the trial and included in the analysis.

**Table 4: Total cost for first year of life per child and cost per item by CHER cohort [2009 USD]**

| Cost (% of total cost)                   | Early treatment<br>(CHER trial arm 2 and 3) | Deferred treatment<br>(CHER trial arm 1) |
|--|---|--|
| <b>Outpatient cost (% of total cost)</b> | \$1,004 (74%)                               | \$1,195 (49%)                            |
| - Drug cost                              | \$245 (18%)                                 | \$127 (5%)                               |
| - Diagnostics                            | \$243 (18%)                                 | \$341 (14%)                              |
| - Staff and overhead cost                | \$515 (38%)                                 | \$726 (30%)                              |
| <b>Inpatient cost (% of total cost)</b>  | \$346 (26%)                                 | \$1,237 (51%)                            |
| <b>Total cost (95% CI<sup>2</sup>)</b>   | \$1,349 (1,244-1,464)                       | \$2,432 (1,982-2,889)                    |

As can be seen in Table 4, there is a clear inverse relationship between the speed with which children were initiated on ART and the inpatient cost they accrued during their first year of life. This inpatient cost explains most of the dramatic difference in cost between the care scenarios. While in the early treatment arm of the CHER trial, children were hospitalised for a mean of 2 days, children in the deferred treatment arm were hospitalised for an average of 5 days. Compared to total average cost, the cost of ARV and other drugs is small in each scenario, with 18% and 5% for the early treatment and deferred treatment arms, respectively.

### **8.3.4 Comparison with the cost of routine care in children initiating ART in the first year of life**

In order to give an indication of how the trial results compare to routine implementation, we compared the cost of ART in the two trial arms with the outpatient and inpatient resource use of 138 infants who had initiated ART during their first year of life at Empilweni Clinic, the paediatric ART clinic at Rahima Moosa Mother and Child Hospital, between 2005 and 2007. ART was initiated in these children at a mean age of 27 weeks (median 23.71; IQR 17.79-38.71), at a mean CD% of 19.73 (median 17.90; IQR 12.00-26.00). In part due to the later initiation, follow-up was much shorter than in the trial cohorts, at a mean of 3.96 months (median 3.91 months; IQR 1.56-6.37). Among these infants, average cost of inpatient and outpatient care during the first year of life was more than double that of early therapy at USD 2,908 (95% CI 2,273-3,743), 84% of which was due to inpatient cost, 9% due to staff and overhead costs, 1% due to drug costs, and 2% due to laboratory costs. The very high mean inpatient cost of \$2,523 is due to an average of 13 days of inpatient days for this cohort (with a maximum of 121 days, or four months) - twice as much as even the deferred care trial cohort, and almost 7 times as much as the early treatment cohort. This difference becomes especially stark when compared with the mean follow-up time for each of the cohorts (see Table 2), translating to 0.2, 0.8, and 4.3 inpatient days per patient month of follow-up, respectively.

## **8.4 Discussion**

When comparing the cost during the first year of life of three cohorts of HIV-infected children initiating antiretroviral treatment in a trial at an average of 10 weeks, regardless of immunological and clinical status, with those who initiated treatment when meeting immunological and clinical eligibility criteria at an average of 20 weeks in the same trial, and at 27 weeks in routine care, we found that early treatment initiation was cost-saving in the first year of life compared to both other options, mostly due to a reduction of inpatient cost by 72% and 84% compared to deferred initiation in the trial and in routine care, respectively.

One of the main shortcomings of this analysis is that it was based on observed data only and did not attempt to model cost past the first year of life. Since survival is also higher under early therapy, this strategy, even if more expensive in an evaluation of lifetime cost, is however likely to be cost-effective. A second limitation was that the estimation of inpatient cost was based on the average cost per inpatient day across all wards in one representative children's hospital, in the absence of complete inpatient resource use data captured during the CHER trial. This assumes that children with HIV cost the same on average as all other children which is very likely an underestimation. The cost estimates we present for all scenarios are therefore conservative; the real costs of inpatient care are likely to be higher, possibly by much, and, since the children in the deferred arm were sicker on average than those in the early treatment arm, the cost differences and hence the cost saving from early initiation are potentially much greater than estimated here. This difference will potentially be much greater still when compared to routine care. Third, the cost of screening of all HIV-exposed children is not included; based on the cost of a PCR test in South Africa and unpublished data about the HIV yield of early infant diagnosis at the time of the analysis in South Africa, we estimate that this would add about \$300 per child. Fourth, in terms especially of the generalisability of these findings to other countries, the early treatment arm of the trial was different from how early treatment will likely be implemented in practice, in that it had very good follow-up and all children were initiated on an LPV/r-containing regimen. Loss to follow-up along the care cascade between testing and treatment initiation in routine care is expected to be 50% even in programmes with the best reported follow-up [7]. All cohorts were furthermore limited to children surviving to ART initiation, and in the case of the routine care cohort, the convenience sample of cases included in this analysis might have introduced a strong selection bias. Lastly, the difference in cost depends on children being presented for hospital admission when sick, which might not always be the case, especially in poorer countries.

Based on the 2010 World Health Organization recommendations, a number of countries, including South Africa, has since implemented a policy of early paediatric treatment initiation for HIV-positive children immediately after the first positive test result. Over the last five years, the South African government has successively increased the age limit for this policy from 1 to 3 to 5 years of age [8].

## **8.5 Conclusion**

In HIV-infected infants, initiating early ART at a median age of 7 weeks is cost-saving in the first year of life compared with deferring ART until an average age of 20 weeks, at which children in a clinical trial with regular monitoring qualified based on clinical grounds, or until 27 weeks, at which children in our sample were initiated in routine care. While with deferred treatment, inpatient and outpatient treatment costed about the same in our analysis, in routine care, the much lower outpatient care costs are overwhelmed by high inpatient costs before ART initiation. “Routine” care with delayed access to ART is, at more than twice the average cost during the first year of life as early treatment, in fact exceptionally expensive. The fact that children in our sample of routine care were followed up for an average of three months only in their first year of life also points to the much higher risk of loss to follow-up and mortality in this sample.

## **References**

1. Lallemand M, Chang S, Cohen R, Pecoul B: Pediatric HIV — A Neglected Disease? *N Engl J Med* 365;7:581-3
2. Violari A, Cotton MF, Gibb DM, Babiker AG, Steyn J, Madhi SA, Jean-Philippe P, McIntyre JA: Early Antiretroviral Therapy and Mortality among HIV-Infected Infants. *N Engl J Med* 2008;359:2233-44.
3. Cotton MF, Violari A, Otwombe K, Panchia R, Dobbels E, Rabie H, et al, for the CHER Study Team: Early time-limited antiretroviral therapy versus deferred therapy in South African infants infected with HIV: results from the children with HIV early antiretroviral (CHER) randomised trial. *Lancet* 382(9904):1555-63 (2013)
4. World Health Organization: WHO recommendations on the diagnosis of HIV infection in infants and children. Geneva, 2010.
5. World Health Organization: Antiretroviral Therapy for HIV Infection in Infants and Children: Towards Universal Access. Recommendations for a public health approach. 2010 revision. Geneva, 2010.
6. National Treasury, Republic of South Africa: Budget Review 2010. Pretoria 2010
7. Ciaranello AL, Park J-E, Ramirez-Avila L, Freedberg KA, Walensky RP, Leroy V: Early infant HIV-1 diagnosis programs in resource-limited settings: opportunities for improved outcomes and more cost-effective interventions. *BMC Medicine* 2011, 9:59
8. National Department of Health, South Africa: Initiation of antiretroviral treatment (ART) to all HIV positive children aged 5 years and under regardless of CD4 count and/ or WHO clinical staging. Circular Minute 2 of 2012 (2012)

## **9 Modelling the cost of the South African national treatment programme**

### **9.1 Introduction**

South Africa is home to both the largest number of HIV-infected people and the largest number of patients on antiretroviral treatment (ART) in the world [1]. The public-sector ART programme started in April 2004 had initiated more than 1 million patients by February 2010, of whom 919,923 were reported as remaining on treatment as of November 2009 [2]. Demand for treatment had increased rapidly to over 300,000 new patients initiated per year, placing tremendous pressure on funding and service delivery capacity. At the same time, government, clinicians, and civil society debated a range of changes to the national ART guidelines, all of which would have considerable implications for the cost of the programme.

In 2009, the South African National Department of Health created a task team to calculate the resources required for national ART provision between 2009/10 and 2016/17, while also considering the potential costs of the proposed changes to the national ART guidelines. These changes included adopting the World Health Organization's (WHO) updated ART guidelines for resource-limited settings, which increase the immunological threshold for eligibility from <200 CD4 cells/microl to <350 CD4 cells/microl and replace stavudine (d4T) with tenofovir (TDF) in first-line ART for newly initiated adults [3]. Proposed changes to the paediatric ART guidelines included initiating on treatment all children <12 months who test positive by HIV PCR, regardless of clinical or immunological status, and the replacement of stavudine with abacavir (ABC) in first-line regimens for newly initiated children. Other changes the task team considered were task-shifting from doctors to nurses and from pharmacists to pharmacy assistants and replacing the existing system of antiretroviral drug procurement via government tenders that favour domestic production with drugs sourced internationally at ceiling prices negotiated by the Clinton Foundation.

To help the Department of Health assess the likely effect of these changes on ART programme costs and to improve the accuracy of national HIV/AIDS budget projections, the task team commissioned the development of a health-state transition model that combined primary data on patient costs and outcomes with existing national projections of patient numbers. The model allows the Department to estimate current and future budgetary needs, assess proposed treatment guideline changes, and calibrate programme expansion to financial resources. In 2010, the results of the model were among the factors that led the South African Government to revise its treatment guidelines and nearly double the budget allocation for ART. Here we present the model and the estimated total cost of the old and new guidelines.

## 9.2 Methods

### 9.2.1 Model structure

We developed a dynamic population model to estimate the number of patients in care over seven financial years (2010/11 to 2016/17). Based on a total population of HIV-infected individuals in need of ART, the model calculates the number of patients on first-line ART, the number who fail first-line ART, and the number who initiate second-line ART (Figure 1). During each 6-month time interval, patients can either transition between these sub-populations, be lost to follow up, or die, according to estimated rates of ART coverage, treatment failure, loss to follow-up (LTFU), and death.

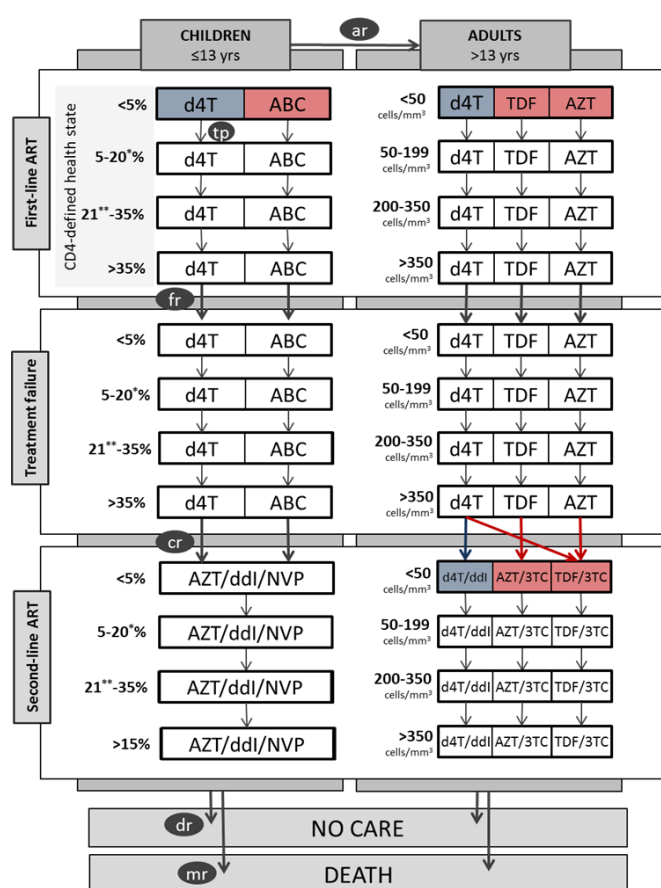

**Figure 1: Health-state transition model**

with ar: age rate, tp: transition probability, fr: failure rate, cr: rate of coverage with second-line ART, dr: default rate, mr: mortality rate. Blue arrows and boxes represent drug choices and transitions under the Old Guidelines scenario, red arrows and boxes represent the New Guidelines and Full WHO Guidelines scenarios. Drugs and transitions that are the same in all scenarios are represented in grey and white. For better legibility, rates are represented for the first row or column only; for drug choices, colours in the first row are representative of all rows, and only those drugs that change between scenarios are mentioned.

\*15% and \*\*16% for children in the age group 6-13

Within each of the sub-populations, we used a health-state transition model to calculate the number of patients in each CD4 cell count/ percentage stratum. For adults, CD4 strata are defined according to differences in mortality and LTFU and categorised as >350, 200-350, 50-199, and <50 cells/microl. For children aged 6 to 13, CD4 strata are defined as >35, 15-35, 5-14, and <5%. CD4 strata for children <6 are CD4 >35, 20-35, 5-19, and <5%. The probabilities of transitioning between these strata vary by age,



CD4 cell count, type of treatment, and, for adult first-line ART, time on treatment. The equations used in the model can be found in the Appendix to chapter 9.

Table 5 summarises the main model elements and their sources, including which of the previous chapters contain a description of the data and methods involved in their estimation.

**Table 5: Summary of model elements and data sources for NACM**

| Model element                                       | Data source  |
|---|--|
| Health states                                       | Defined by differences in mortality in TLC data  |
| Number of adults initiating ART                     | ASSA2003   |
| Number of children initiating ART                   | ASSA2003 (plus additional assumptions regarding scale-up of Early Paediatric Treatment (EPT); for separate analysis of EPT, see Chapter 8) |
| Mortality   | TLC/ HSCC data   |
| Loss to follow-up                                   | TLC/ HSCC data   |
| First-line treatment failure                        | TLC/ HSCC data   |
| Incidence of side effects necessitating drug change | TLC data (applies to adults only)  |
| Transition probabilities between health states      | TLC/ HSCC data   |
| Outpatient cost (adults)                            | CMH/ TWC data (see Chapter 5)  |
| Inpatient cost (adults)                             | CHBH/ TH data (see Chapter 6)  |
| Outpatient cost (children)                          | HSCC/ ESRU data (see Chapter 7)  |

*ASSA2003* Actuarial Society of South Africa AIDS Model 2003; *TLC* Themba Lethu Clinic; *HSCC* Harriet Shezi Children's Clinic; *CMH* Charlotte Maxeke Hospital; *TWC* Tshepong Wellness Clinic; *CHBH* Chris Hani Baragwanath Hospital; *TH* Tintswalo Hospital; *ESRU* Empilweni Services and Research Unit

### 9.2.2 Scenarios for analysis

We analysed numbers of people initiating ART, their survival in care and the resulting cost under three scenarios (Table 6). The Old Guidelines scenario kept the same eligibility thresholds (<200 CD4 cells/microl or WHO stage 4 for adults or 15%-20% of total lymphocyte count or WHO stage 3 or 4 for children) and ART regimens (d4T + 3TC + EFV or NVP as first line, AZT + ddI+ LPV/r as second line for adults and children above 3 years of age; d4T + 3TC + LPV/r as first line, AZT + ddI + NVP as second line for children below 3 years of age) for adults and children as the 2004 South African ART guidelines [3]. Under the New Guidelines scenario, the adult eligibility threshold was raised to <350 cells/microl for patients with TB and for pregnant women while continuing to initiate all other adults at <200 cells/microl, and treatment was initiated for all HIV-positive babies <12 months of age immediately after the first positive PCR (Early Paediatric Treatment). The New Guidelines scenario also replaced d4T in first-line regimens with TDF for adults and abacavir (ABC) for infants for newly initiated patients or those experiencing severe d4T toxicity. Finally, the Full WHO Guidelines scenario increased the eligibility threshold to <350 cells/microl for all adults, while keeping paediatric eligibility and all regimens the same as in the New Guidelines scenario. We assumed that survival in care would change between scenarios as a function of the higher eligibility threshold (calculated based on CD4 cell count dependent transition

probabilities), but would be the same between different drug regimens; both eligibility and drug regimen changes however impacted on cost.

**Table 6: Scenarios of analysis**

| Scenario                     |                 | Old Guidelines  | New Guidelines   | Full WHO Guidelines                  |
|------------------------------|-----------------|---|--|--------------------------------------|
| <b>Eligibility criterion</b> |                 |   |  |                                      |
| <b>Adults</b>                |                 | <200 CD4 cells/microl or WHO stage 4                        | For HIV/ TB co-infected and pregnant patients:<br><350 CD4 cells/microl<br>For all other patients:<br><200 CD4 cells/microl or WHO stage 4 | <350 CD4 cells/microl or WHO stage 4 |
| <b>Children</b>              |                 | 15% to 20% of total lymphocyte count or WHO stage 3/4       | After first positive PCR in 1 <sup>st</sup> year of life, regardless of CD4 cell percentage or WHO stage (Early Paediatric Treatment)      |                                      |
| <b>Drug regimens</b>         |                 |   |  |                                      |
| <b>First-line</b>            | <b>Adults</b>   | d4T + 3TC + EFV or NVP                                      | For all new initiates and those with d4T toxicity:<br>TDF + 3TC + EFV or NVP<br>For all else:<br>d4T + 3TC + EFV or NVP                    |                                      |
| <b>Second-line</b>           |                 | AZT + ddl+ LPV/r  | For those failing d4T- or AZT-containing regimens:<br>TDF + 3TC + LPV/r<br>For those failing TDF-containing regimens:<br>AZT + 3TC + LPV/r |                                      |
| <b>First-line</b>            | <b>Children</b> | <3 yrs: d4T + 3TC + LPV/r<br>>3 yrs: d4T + 3TC + EFV or NVP | <3 yrs: ABC + 3TC + LPV/r<br>>3 yrs: ABC + 3TC + EFV or NVP  |                                      |
| <b>Second-line</b>           |                 | <3 yrs: AZT + ddl + NVP<br>>3 yrs: AZT + ddl + LPV/r        |  |                                      |

Within each of the scenarios, we also examined two other proposed changes: the impact of task-shifting, defined as ART initiation and management by nurses under physician supervision and the dispensation of ART by pharmacy assistants under pharmacist supervision; and the impact of procuring antiretroviral drugs at Clinton Foundation ceiling prices and wherever possible as fixed-dose combinations (FDC).

## 9.2.3 Data sources and assumptions

### 9.2.3.1 Population in need and initiating ART

The model calculates the cost of treating all patients in need of ART between 2010/11 and 2016/17, including those patients already in care by the beginning of the financial year 2010/11, in April 2010 (965,005 adults and 336,267 children). Data on the population in need of and initiating ART were obtained from an adaptation of the Actuarial Society of South Africa (ASSA) AIDS model from 2003 (ASSA2003) [4,5]. This update includes the breakdown of the population assumed to initiate ART by CD4 cell count, allowing patients to enter care in a specified CD4 count stratum. The model allows for a change in the number of patients initiating care if immunological eligibility is defined at <350 CD4 cells/ $\mu$ l

rather than <200 cells/μl. In line with the South African National Strategic Plan for HIV and AIDS & STIs for 2007-2011, the number of individuals starting ART per year was assumed to be 80% of those newly eligible for ART from 2009/10 onward [6], of whom 90% were assumed to be treated in the public sector. Under the Full WHO Guidelines scenario, we assumed that the rate of ART initiation in adults with CD4 cell counts of 200-350 cells/microl was 30% of the rate of ART initiation in adults with CD4 cell counts <200 cells/microl. Coverage of children with Early Paediatric Treatment was assumed to increase from 55% in 2010/11 to 85% in 2016/17.

The assumption that the rate of ART initiation in adults with CD4 cell counts of 200-350 cells/microl is 30% of the rate of ART initiation in adults with CD4 cell counts <200 cells/microl under the Full WHO Guidelines scenario, is based on the CD4 cell count profile in people starting ART in the Aid for AIDS programme, compared to the CD4 cell count distribution in the general population [5]. The Aid for AIDS programme is a South African medical aid programme that started providing ART in the private sector in 2001, well before the public-sector roll-out in 2004. Protocol was to start ART in all patients with CD4 cell counts of <350 cells/microl. During 2001-2002, only 67% of patients initiated ART with CD4 cell counts of <200 cells/microl, with the rest initiating with CD4 cell counts between 200 and 350 cells/microl. In the same time period, the proportion of the untreated HIV-positive population in the <200 cells/microl and 200-350 cells/microl categories were 13% and 24% respectively.

If  $r$  is the rate of ART initiation in the CD4 <200 cells/microl category and  $x$  is the relative rate of ART initiation in the CD4 200-350 cells/microl category then

$$0.67 = 0.13r / (0.13r + 0.24 * rx)$$

from which it follows that

$$x = (0.13/0.67 - 0.13)/0.24$$

which solves to 27% which we rounded up to 30% for this analysis.

It should be noted that neither the model nor the ASSA2003 model that produces the numbers of people initiating ART takes into account an impact of treatment coverage on the numbers of people requiring ART in the future, as under the eligibility scenarios evaluated here any impact of ART coverage on transmission and incidence would only reduce numbers of people requiring ART beyond the 6 year time horizon that the model calculates.

Table 7 gives the details of the numbers of patients assumed to be added between 2010/11 and 2016/17 under the different scenarios, and assumptions regarding the distribution of initiating patients into health states.

**Table 7: Assumptions regarding target population and coverage**

| Parameter  | Value                   |         | Source   |
|--|-------------------------|---------|--|
| Number of adults initiating ART<br>( <i>Old Guidelines</i> )   | 2010/11                 | 399,548 | ASSA2003 adapted to reflect 64.20% coverage from 2005 onwards [4]<br>1,525,087<br>1,461,836<br>1,408,444<br>1,360,833  |
|  | 2011/12                 | 401,892 |  |
|  | 2012/13                 | 395,343 |  |
|  | 2013/14                 | 384,941 |  |
|  | 2014/15                 | 374,339 |  |
|  | 2015/16                 | 364,228 |  |
|  | 2016/17                 | 355,174 |  |
| Number of adults initiating ART<br>( <i>New Guidelines</i> )   | 2010/11                 | 478,502 | ASSA2003, together with a CD4 cell count staging model [5] and assumptions regarding TB incidence and CD4 cell count distribution in pregnant HIV+ women (see below) |
|  | 2011/12                 | 468,852 |  |
|  | 2012/13                 | 454,751 |  |
|  | 2013/14                 | 434,367 |  |
|  | 2014/15                 | 416,497 |  |
|  | 2015/16                 | 401,392 |  |
|  | 2016/17                 | 387,898 |  |
| Number of adults initiating ART<br>( <i>Full WHO Guidelines</i> )  | 2010/11                 | 584,141 | ASSA2003, together with CD4 cell count staging model [5]   |
|  | 2011/12                 | 558,948 |  |
|  | 2012/13                 | 520,776 |  |
|  | 2013/14                 | 480,671 |  |
|  | 2014/15                 | 445,254 |  |
|  | 2015/16                 | 416,514 |  |
|  | 2016/17                 | 390,472 |  |
| Proportion of adults with CD4 cell counts between 200 and 50 cells/mm <sup>3</sup> out of those initiating ART with CD4 cell counts <200<br>( <i>All scenarios</i> ) | 2010/11 to 2011/12: 0.8 |         | Authors' assumption  |
|  | 2012/13 to 2016/17: 0.9 |         |  |
| Proportion of adults initiating ART in the public sector<br>( <i>All scenarios</i> )   | 0.90                    |         | [5]  |
| Number of children initiating ART<br>( <i>Old Guidelines</i> )   | 2010/11                 | 46,512  | ASSA2003   |
|  | 2011/12                 | 44,123  |  |
|  | 2012/13                 | 41,026  |  |
|  | 2013/14                 | 37,206  |  |
|  | 2014/15                 | 33,071  |  |
|  | 2015/16                 | 29,679  |  |
|  | 2016/17                 | 27,163  |  |
| Number of children initiating ART under Early Paediatric Treatment<br>( <i>New Guidelines + Full WHO Guidelines</i> )  | 2010/11                 | 73,132  | modelled based on numbers of births to HIV-positive mothers and proportion breastfeeding from ASSA2003   |
|  | 2011/12                 | 69,164  |  |
|  | 2012/13                 | 66,228  |  |
|  | 2013/14                 | 64,297  |  |
|  | 2014/15                 | 60,254  |  |
|  | 2015/16                 | 56,902  |  |
|  | 2016/17                 | 54,377  |  |
| Of above, proportion of children initiating ART by CD4% stratum<br>( <i>Old Guidelines</i> )   | >35%                    | 0.01    | Authors' assumption  |
|  | 21%-35%                 | 0.04    |  |
|  | 5%-20%                  | 0.05    |  |

|  |                          |         |                                |
|--|--------------------------|---------|--------------------------------|
|  | <5%                      | 0.90    |                                |
| Of above, proportion of children <12 months initiating Early Paediatric Treatment by CD4% stratum<br>( <i>New Guidelines + Full WHO Guidelines</i> )                         | >35%                     | 0.25    | Authors' assumption            |
|  | 21%-35%                  | 0.05    |                                |
|  | 5%-20%                   | 0.30    |                                |
|  | <5%                      | 0.40    |                                |
| Proportion of children initiating ART in the public sector<br>( <i>Old Guidelines</i> )  | 0.90                     |         | [5]                            |
| Proportion of children below 12 months initiating Early Paediatric Treatment in the public sector<br>( <i>New Guidelines + Full WHO Guidelines</i> ) <sup>11</sup>           | 2010/11                  | 0.55    | Authors' assumption            |
|  | 2011/12                  | 0.60    |                                |
|  | 2012/13                  | 0.65    |                                |
|  | 2013/14                  | 0.70    |                                |
|  | 2014/15                  | 0.75    |                                |
|  | 2015/16                  | 0.80    |                                |
|  | 2016/17                  | 0.85    |                                |
| Incidence of TB in patients with CD4 cell counts between 200 and 350 cells/microl not on ART (per 100 patient years)<br>( <i>New Guidelines</i> )                            | Western Cape: 10         |         | [7]                            |
|  | all other provinces: 5.7 |         | N. Martinson, unpublished data |
| Number of births to HIV-positive mothers<br>( <i>New Guidelines + Full WHO Guidelines</i> )  | 2010/11                  | 256,984 | ASSA2003                       |
|  | 2011/12                  | 259,260 |                                |
|  | 2012/13                  | 261,135 |                                |
|  | 2013/14                  | 262,506 |                                |
|  | 2014/15                  | 263,348 |                                |
|  | 2015/16                  | 263,679 |                                |
|  | 2016/17                  | 263,533 |                                |
| Ratio of pregnancies to births in HIV-positive women with CD4 cell counts between 200 and 350 cells/microl<br>( <i>New Guidelines + Full WHO Guidelines</i> )                | 1:0.95                   |         | [8]                            |
| Proportion of pregnant women with CD4 cell counts between 200 and 350 cells/microl out of all pregnant HIV-positive women<br>( <i>New Guidelines + Full WHO Guidelines</i> ) | 0.25                     |         | Unpublished data               |

### 9.2.3.2 Early Paediatric Treatment

The number of HIV-positive children requiring Early Paediatric Treatment in the New Guidelines and the Full WHO Guidelines scenarios was calculated based on the assumed uptake of HIV testing in pregnancy, PMTCT coverage and effectiveness, and the proportion of HIV-positive mothers assumed to be breastfeeding. For this, all PMTCT was assumed to be dual therapy comprised of single dose NVP intrapartum to mother and single dose NVP immediately postnatally to child plus AZT for twelve weeks antenatally and single dose intrapartum to the mother, plus AZT one week postnatally to both mother and child.

<sup>11</sup> Children not covered by Early Paediatric Treatment are assumed to initiate ART only once AIDS-sick

### **9.2.3.3 Rates of death, loss to follow-up, and transition between CD4 cell count strata**

We calculated rates of mortality, LTFU, treatment failure and development of side effects necessitating regimens changes amongst adult patients using data of 9,502 adult patients accessing ART at Themba Lethu Clinic (TLC), Helen Joseph Hospital, Johannesburg between April 2004 and May 2009. During this time period, the clinic initiated 10,200 adult patients on ART, rendering it one of the largest adult ART clinics in South Africa, and providing patients meeting government eligibility criteria with standard public sector ART (stavudine (d4T), lamivudine (3TC) and either efavirenz (EFV) or nevirapine (NVP) as first line and didanosine (ddI), lopinavir/ritonavir (LPV/r) and zidovudine (AZT) as second line). CD4 cell counts and HIV viral loads were monitored at roughly 6-monthly intervals after ART initiation. Data on mortality, loss to follow-up, and treatment failure rates amongst paediatric patients (14 years and younger) was based on an analysis of data from a longitudinal cohort of paediatric patients accessing ART at Helen Shezi Paediatric Clinic at Chris Hani Baragwanath Hospital, Gauteng, between April 2004 and May 2009. During this time period, the clinic initiated around 4,000 paediatric patients on ART, making the clinic one of the largest paediatric ART clinics in the world.

For the analysis of mortality, loss to follow-up (LTFU), and failure rates on first-line treatment, we included all adult patients on regimens not containing a protease inhibitor in the first-line sub-population, and all children on first-line regimens as specified in the 2004 South African guidelines. Any previously virologically suppressed patient with two consecutive unsuppressed viral loads (>400 copies/ml for adults, >1000 copies/ml for children) was transitioned to the treatment failure (TF) sub-population, and any patient in the TF sub-population who switched to a protease-inhibitor containing regimen was transitioned to the second-line sub-population. Within each sub-population, we stratified all events (death, LTFU, treatment failure) by the patient's last CD4 measure within a 6-month interval, and for adult patients on first-line ART, also by the patient's time on ART. For patients missing a single 6-month CD4 cell count, we linearly interpolated this value from the adjacent CD4 cell counts. For children, we additionally corrected for a non-linear relationship between time and CD4 percentage during the first six months on treatment [22].

LTFU was defined as >6 months since last clinic visit and was net of patients returning back into care during the same time period in which they were lost. Mortality, LTFU, and transitions between health states were independent of whether d4T or TDF/ ABC were used. Deaths were considered only if the patient could be linked to an entry in the national death register. If patients were confirmed dead more than six months after their last visit to the clinic, they were classified as lost to follow up rather than dead, as their deaths would most likely have taken place after the patients had discontinued treatment. Data were collected by clinic staff for routine patient management purposes in electronic databases (TherapyEdge™ in Themba Lethu Clinic, Microsoft Access in Harriet Shezi Children's Clinic) and abstracted, cleaned, and analysed using SAS version 9.1.

Some of our estimates of mortality, loss and treatment failure within the sub-strata of CD4 count and time were unstable. In order to prevent undue influence of any single estimate on the results and to account for the variability in the estimates, we smoothed the estimated probabilities within CD4 count and time stratum. To do this, we first fit a simple linear regression model with the estimated probabilities (stratified by CD4 count) as the dependent variable and time (fit as a quadratic line by also including time squared) as the independent variable. This gave us a predicted probability for each time point and CD4 count stratum. The actual estimated probability from the data was then shrunk towards the predicted value as a function of the variance of the estimate using an Empirical-Bayes shrinkage estimator [23]. This resulted in estimated probabilities with low variance being far from the predicted curve and those with high variance being very close to the fitted line. Figure 2 summarises the impact of this fitting procedure on rates of mortality, loss to follow-up and treatment failure in selected adult health states.

**Figure 2: Selected results of linear regression and Empirical-Bayes shrinkage for time-dependent rates of mortality (A), loss to follow up (LTF, B) and first-line treatment failure (C), all for adults with CD4 cell counts > 350 cells/microl**

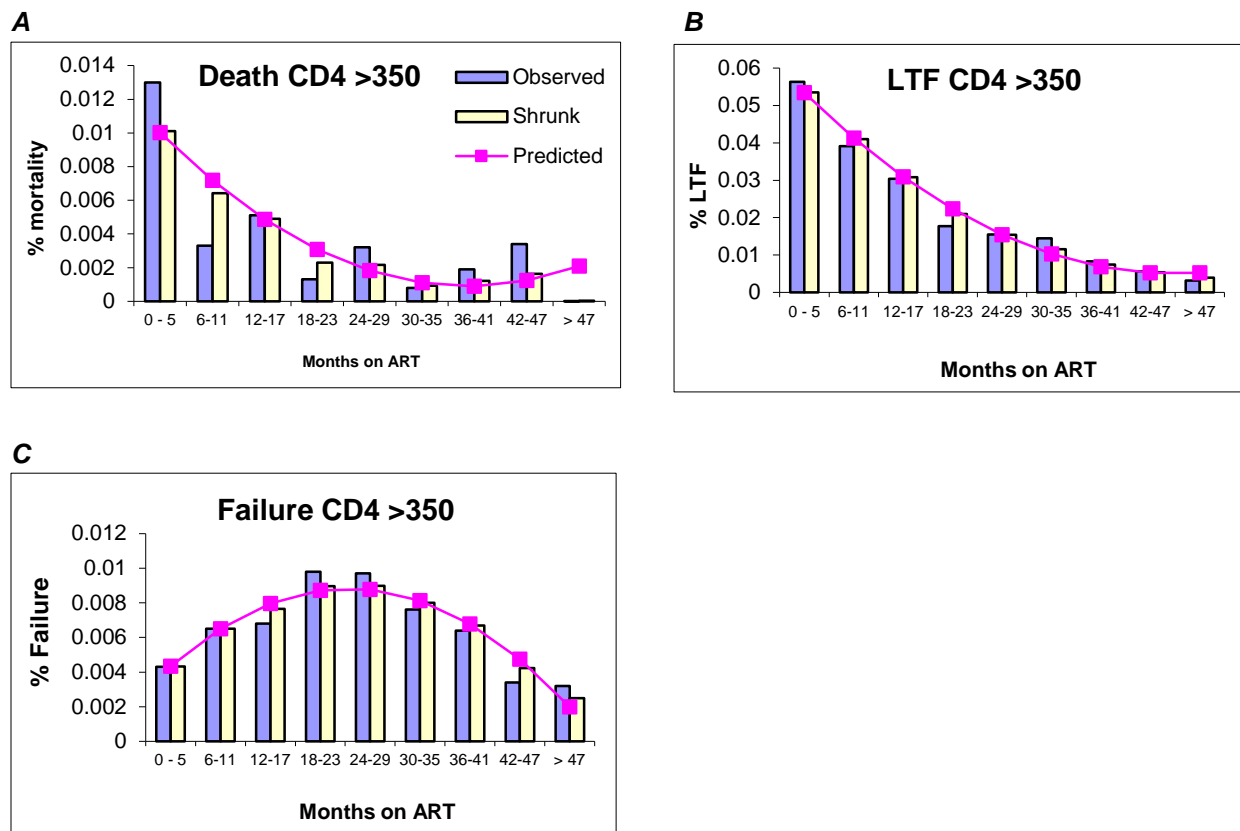

The resulting rates of mortality and LTFU and transitions between health states can be found in Table 8 below (adults) and in Table 1 in the appendix (children).

**Table 8: Probabilities of death, loss to follow-up, and treatment failure and transition probabilities between CD4 cell-count defined health states per 6-month cycle, by type of treatment, CD4 cell count stratum, and (for first-line ART) time on treatment (Adults)**

| First-line ART (Adults)                               |                        |                          |  |  |                               |                               |                            |
|---|------------------------|--------------------------|--|--|-------------------------------|-------------------------------|----------------------------|
| Months on first-line ART                              | 6-month probability of |                          |  | Probability of transition to CD4 cell count stratum: |                               |                               |                            |
|   | Death                  | Loss to follow-up        | Treatment failure                                    | <50 cells/mm <sup>3</sup>                            | 50-199 cells/mm <sup>3</sup>  | 200-350 cells/mm <sup>3</sup> | >350 cells/mm <sup>3</sup> |
| <b>if CD4 cell count &gt;350 cells/mm<sup>3</sup></b> |                        |                          |  |  |                               |                               |                            |
| 1 - 6   | 1.6%                   | 5.4%                     | 0.5%   | 0%   | 2.9%                          | 10.7%                         | 86.4%                      |
| 7-12  | 1.6%                   | 4.2%                     | 0.8%   | 0%   | 1.9%                          | 17.7%                         | 80.4%                      |
| 13-18   | 1.6%                   | 3.2%                     | 0.9%   | 0.2%   | 0.9%                          | 10.4%                         | 88.5%                      |
| 19-24   | 1.6%                   | 2.0%                     | 0.9%   | 0.07%  | 0.5%                          | 9.6%                          | 89.8%                      |
| 25-30   | 0%                     | 1.6%                     | 1.0%   | 0.07%  | 1.3%                          | 9.5%                          | 89.2%                      |
| 31-36   | 0%                     | 1.2%                     | 0.8%   | 0%   | 0.7%                          | 8.0%                          | 91.3%                      |
| 37-42   | 0.1%                   | 0.6%                     | 0.6%   | 0.2%   | 0.5%                          | 9.2%                          | 90.1%                      |
| 43-48   | 0.1%                   | 0.6%                     | 0.5%   | 0.3%   | 0.5%                          | 7.5%                          | 91.8%                      |
| >48   | 0%                     | 0.4%                     | 0.3%   | 0.1%   | 0.9%                          | 5.4%                          | 93.6%                      |
| <b>if CD4 cell count 200-350 cells/mm<sup>3</sup></b> |                        |                          |  |  |                               |                               |                            |
| 1 - 6   | 1.4%                   | 5.1%                     | 0.1%   | 0.7%   | 8.4%                          | 57.0%                         | 33.8%                      |
| 7-12  | 1.0%                   | 3.6%                     | 0.9%   | 0.3%   | 7.8%                          | 62.3%                         | 29.7%                      |
| 13-18   | 0.4%                   | 2.9%                     | 1.4%   | 0.2%   | 5.4%                          | 57.2%                         | 37.3%                      |
| 19-24   | 0.5%                   | 2.3%                     | 1.6%   | 0.07%  | 5.2%                          | 63.2%                         | 31.5%                      |
| 25-30   | 0.3%                   | 1.9%                     | 1.5%   | 0.09%  | 5.8%                          | 63.8%                         | 30.3%                      |
| 31-36   | 0.3%                   | 1.6%                     | 1.6%   | 0%   | 4.5%                          | 63.9%                         | 31.6%                      |
| 37-42   | 0%                     | 1.4%                     | 1.6%   | 0%   | 5.1%                          | 61.3%                         | 33.6%                      |
| 43-48   | 0.2%                   | 1.3%                     | 1.0%   | 0%   | 5.9%                          | 56.3%                         | 37.9%                      |
| >48   | 0.2%                   | 1.1%                     | 0.7%   | 0%   | 5.4%                          | 56.9%                         | 37.6%                      |
| <b>if CD4 cell count 50-199 cells/mm<sup>3</sup></b>  |                        |                          |  |  |                               |                               |                            |
| 1 - 6   | 2.6%                   | 6.5%                     | 0.3%   | 1.0%   | 39.9%                         | 45.3%                         | 13.8%                      |
| 7-12  | 1.7%                   | 4.7%                     | 1.3%   | 0.9%   | 56.0%                         | 39.0%                         | 4.2%                       |
| 13-18   | 1.2%                   | 4.0%                     | 1.7%   | 1.7%   | 52.7%                         | 41.8%                         | 3.8%                       |
| 19-24   | 1.1%                   | 3.3%                     | 2.1%   | 0.9%   | 52.9%                         | 42.9%                         | 3.4%                       |
| 25-30   | 0.7%                   | 3.1%                     | 2.8%   | 1.2%   | 55.2%                         | 41.3%                         | 2.3%                       |
| 31-36   | 0.5%                   | 2.5%                     | 3.2%   | 0.5%   | 54.8%                         | 38.6%                         | 6.1%                       |
| 37-42   | 0.4%                   | 2.8%                     | 3.4%   | 0%   | 54.3%                         | 38.8%                         | 6.9%                       |
| 43-48   | 0%                     | 3.0%                     | 4.2%   | 0%   | 50.9%                         | 43.6%                         | 5.5%                       |
| >48   | 0%                     | 3.2%                     | 4.9%   | 0%   | 54.3%                         | 31.4%                         | 14.3%                      |
| <b>if CD4 cell count &lt;50 cells/mm<sup>3</sup></b>  |                        |                          |  |  |                               |                               |                            |
| 1 - 6   | 8.0%                   | 9.7%                     | 0.6%   | 11.6%  | 71.2%                         | 15.0%                         | 2.2%                       |
| 7-12  | 5.9%                   | 7.5%                     | 1.2%   | 23.6%  | 65.2%                         | 9.4%                          | 1.7%                       |
| 13-18   | 5.8%                   | 6.0%                     | 2.4%   | 31.4%  | 45.1%                         | 19.6%                         | 3.9%                       |
| 19-24   | 5.3%                   | 4.8%                     | 0.0%   | 29.4%  | 50.0%                         | 11.8%                         | 8.8%                       |
| 25-30   | 0%                     | 4.1%                     | 7.8%   | 25.0%  | 58.3%                         | 8.3%                          | 8.3%                       |
| 31-36   | 0%                     | 0%                       | 0.0%   | 25.0%  | 50.0%                         | 25.0%                         | 0%                         |
| 37-42   | 3.8%                   | 6.6%                     | 0.0%   | 0%   | 33.3%                         | 33.3%                         | 33.3%                      |
| 43-48   | 0%                     | 9.0%                     | 0.0%   | 0%   | 33.3%                         | 33.3%                         | 33.3%                      |
| >48   | 0%                     | 0%                       | 0.0%   | 0%   | 33.3%                         | 33.3%                         | 33.3%                      |
| <b>First-line treatment failure (Adults)</b>          |                        |                          |  |  |                               |                               |                            |
| Probability of  |                        |                          | Probability of transition to CD4 cell count stratum: |  |                               |                               |                            |
| Death   | Loss to follow-up      | Switching to second line | <50 cells/mm <sup>3</sup>                            | 50-199 cells/mm <sup>3</sup>                         | 200-350 cells/mm <sup>3</sup> | >350 cells/mm <sup>3</sup>    |                            |
| <b>if CD4 cell count &gt;350 cells/mm<sup>3</sup></b> |                        |                          |  |  |                               |                               |                            |
| 0%  | 2.9%                   | 81.7%                    | 0%   | 2.6%   | 17.4%                         | 80.0%                         |                            |
| <b>if CD4 cell count 200-350 cells/mm<sup>3</sup></b> |                        |                          |  |  |                               |                               |                            |
| 0.8%  | 5.5%                   | 77.3%                    | 0%   | 16.2%  | 61.9%                         | 21.9%                         |                            |



| if CD4 cell count 50-199 cells/mm <sup>3</sup>  |                   |  |                              |                               |                            |      |
|---|-------------------|--|------------------------------|-------------------------------|----------------------------|------|
| 1.3%  | 5.0%              | 76.8%  | 7.7%                         | 66.3%                         | 24.0%                      | 1.9% |
| if CD4 cell count <50 cells/mm <sup>3</sup>     |                   |  |                              |                               |                            |      |
| 2.8%  | 7.0%              | 75.7%  | 32.3%                        | 58.1%                         | 9.7%                       | 0%   |
| Second-line ART (Adults)                        |                   |  |                              |                               |                            |      |
| Probability of                                  |                   | Probability of transition to CD4 cell count stratum: |                              |                               |                            |      |
| Death   | Loss to follow-up | <50 cells/mm <sup>3</sup>                            | 50-199 cells/mm <sup>3</sup> | 200-350 cells/mm <sup>3</sup> | >350 cells/mm <sup>3</sup> |      |
| if CD4 cell count >350 cells/mm <sup>3</sup>    |                   |  |                              |                               |                            |      |
| 0.4%  | 0.3%              | 0.6%   | 0.0%                         | 13.6%                         | 85.8%                      |      |
| if CD4 cell count 200-350 cells/mm <sup>3</sup> |                   |  |                              |                               |                            |      |
| 0.7%  | 0.5%              | 1.0%   | 10.6%                        | 59.6%                         | 28.8%                      |      |
| if CD4 cell count 50-199 cells/mm <sup>3</sup>  |                   |  |                              |                               |                            |      |
| 1.2%  | 0.5%              | 4.0%   | 61.8%                        | 30.2%                         | 4.0%                       |      |
| if CD4 cell count <50 cells/mm <sup>3</sup>     |                   |  |                              |                               |                            |      |
| 5.1%  | 1.3%              | 34.6%  | 50.0%                        | 11.5%                         | 3.8%                       |      |

### 9.2.3.4 Changes between drug regimens

We also calculated rates of toxicity development requiring single-drug substitution of d4T with TDF and of TDF with AZT used in the New Guidelines scenario (Table 9). Estimates of mortality, LTFU, and treatment failure rates amongst paediatric patients ( $\leq 13$ ) were based on data from a cohort of 3,748 paediatric patients accessing ART at Harriet Shezi Children's Clinic (HSSC), Chris Hani Baragwanath Hospital, Johannesburg, between April 2004 and May 2009. Children  $\leq 3$  receive d4T, 3TC and LPV/r as first line and AZT, ddI and either NVP or EFV as second line; children  $> 3$  receive the same regimens as adults.

**Table 9: Assumptions regarding drug toxicity**

| Parameter   | Value |        | Source                 |
|---|-------|--------|------------------------|
| Incidence of severe d4T toxicity in adults (per number of months on treatment)<br>(New Guidelines + Full WHO Guidelines)  | 0 - 5 | 0.0399 | TLC data, based on [9] |
|   | 6-11  | 0.1067 |                        |
|   | 12-17 | 0.1333 |                        |
|   | 18-23 | 0.0621 |                        |
|   | 24-29 | 0.0289 |                        |
|   | 30-35 | 0.0135 |                        |
|   | 36-41 | 0.0063 |                        |
|   | 42-47 | 0.0029 |                        |
|   | > 47  | 0.0014 |                        |
| Incidence of severe renal failure under TDF (per number of months on treatment)<br>(New Guidelines + Full WHO Guidelines) | 0 - 6 | 0.0171 | TLC data               |
|   | > 6   | 0.0158 |                        |

### 9.2.3.5 Cost data

#### 9.2.3.5.1 Outpatient cost

Outpatient resource utilisation and unit costs data were collected at the ART clinic at Charlotte Maxeke Hospital (CMH) in Johannesburg, Gauteng, and at Tshepong Wellness Clinic (TWC) at the Tshepong/

Klerksdorp Hospital Complex in Jouberton, North West province, between 2006 and 2008 for adult ART (see Chapter 5), and at Empilweni Services and Research Unit (ESRU) at Rahima Moosa Mother and Child Hospital and Harriet Shezi Children's Clinic (HSCC), both in Johannesburg, Gauteng, between 2005 and 2009 for paediatric ART (see Chapter 7), and were analysed from the provider perspective. Unit costs were updated to 2011 prices.

We added a number of cost estimates to those presented in Chapters 5 and 7. Data on additional resources involved in treating adult patients with first-line treatment failure and on second-line treatment was obtained from Themba Lethu Clinic (TLC) [10,11]. In order to represent the difference in recommended drug regimens between paediatric age groups, the drug cost component of paediatric ART was additionally based on the mean weight of children in care at HSSC as a guide to average drug dosages by age group (<12 months, 1-5 years, 6-13 years), and for children above the age of 3 cost was further differentiated by age at ART initiation ( $\leq 3$  years,  $>3$  years). Since South Africa secures a buffer stock of 2 months of treatment for every patient initiating treatment, drug costs were increased by 17% in the first six months of treatment. The cost of pre-ART outpatient care was analysed using an ingredients approach based on the national treatment guidelines and includes the cost incurred by patients who were prepared for but never initiated ART, based on data from two large South African clinics [12]. We also added the cost of voluntary counselling and testing for every patient initiating ART [13], including the cost of an HIV PCR test for every child initiated on ART. The annual per patient cost under the three scenarios is summarised in Table 10.

#### **9.2.3.5.2 Inpatient cost**

Inpatient cost was based on an analysis of hospitalisation frequency and duration of patients off and on ART in two hospitals in South Africa (see Chapter 6). We used the results of the sub-analysis after removing events deemed unrelated to HIV, by CD4 cell count stratum and ART status from Table 2B in chapter 6 (see also Table 10).

#### **9.2.3.5.3 Adjustment of cost data by scenario**

Average cost per patient was set to differ between types of treatment (first-line treatment, first-line treatment failure, second-line treatment), drug regimens (d4T- vs. TDF/ABC-containing regimens), and age groups (defined as adults vs. children, and for children depending on current age and age at treatment initiation- see Table 10), but was assumed not to vary by CD4 cell count. For the alternative drug cost scenario, we used Clinton Foundation ceiling prices from August 2009 for ARV costs [14]. For the task-shifting scenario, we replaced all physicians by senior-level nurses and all pharmacists by pharmacy assistants, while allowing for supervision time by the replaced cadre. In the New Guidelines scenario, the number of CD4 cell counts and viral loads per patient are reduced to only one per year.

Inpatient cost inputs by CD4 cell count remained the same across scenarios as these were not affected by the guideline changes under discussion.

**Table 10: Cost inputs in 2011 USD**

| Parameter  | Value  |                            |                  |                                |                  |                   |
|--|--|----------------------------|------------------|--------------------------------|------------------|-------------------|
| <b>1. Outpatient cost by scenario</b>                |  |                            |                  |                                |                  |                   |
| <b>A. Old Guidelines</b>                             |  |                            |                  |                                |                  |                   |
| <b>Annual per patient cost (Adults)</b>              |  |                            |                  |                                |                  |                   |
| Cost of first-line therapy during first six months   | 447.97   |                            |                  |                                |                  |                   |
| Cost of first-line therapy after first six months    | 863.58   |                            |                  |                                |                  |                   |
| Cost of failed first-line therapy                    | 755.30   |                            |                  |                                |                  |                   |
| Cost of second-line therapy                          | 1,578.30   |                            |                  |                                |                  |                   |
| <b>Annual per patient cost (Children)</b>            |  |                            |                  |                                |                  |                   |
|  |  | <b>Initiated at ≤3 yrs</b> |                  | <b>Initiated at &gt;3 yrs</b>  |                  |                   |
|  | <b>&lt;12 mts</b>                                  | <b>12-35 mts</b>           | <b>3-5 years</b> | <b>6-13 years</b>              | <b>3-5 years</b> | <b>6-13 years</b> |
| Cost of first-line therapy during first six months   | 426.19   | 505.57                     | 576.29           | 583.35                         | 479.57           | 511.90            |
| Cost of first-line therapy after first six months    | 645.18   | 781.25                     | 902.48           | 914.58                         | 736.68           | 792.12            |
| Cost of failed first-line therapy                    | 547.70   | 685.44                     | 808.16           | 820.41                         | 668.37           | 696.44            |
| Cost of second-line therapy                          | 815.05   | 994.19                     | 798.72           | 903.40                         | 1,136.92         | 1,189.75          |
| <b>B. New Guidelines + Full WHO Guidelines</b>       |  |                            |                  |                                |                  |                   |
| <b>Annual per patient cost (Adults)</b>              |  |                            |                  |                                |                  |                   |
|  | <b>TDF-containing regimens</b>                     |                            |                  | <b>AZT-containing regimens</b> |                  |                   |
| Cost of first-line therapy during first six months   | 552.18   |                            |                  | 466.49                         |                  |                   |
| Cost of first-line therapy after first six months    | 984.45   |                            |                  | 848.22                         |                  |                   |
| Cost of failed first-line therapy                    | 894.53   |                            |                  | 624.20                         |                  |                   |
| Cost of second-line therapy                          | 1,139.39   |                            |                  | 1,281.57                       |                  |                   |
| <b>Annual per patient cost (Children)</b>            |  |                            |                  |                                |                  |                   |
|  |  | <b>Initiated at ≤3 yrs</b> |                  | <b>Initiated at &gt;3 yrs</b>  |                  |                   |
|  | <b>&lt;12 mts</b>                                  | <b>12-35 mts</b>           | <b>3-5 years</b> | <b>6-13 years</b>              | <b>3-5 years</b> | <b>6-13 years</b> |
| Cost of first-line therapy during first six months   | 797.02   | 937.74                     | 1,023.93         | 1,104.03                       | 609.80           | 715.17            |
| Cost of first-line therapy after first six months    | 736.75   | 977.97                     | 1,125.72         | 1,263.02                       | 959.93           | 1,140.55          |
| Cost of failed first-line therapy                    | 640.39   | 939.72                     | 1,034.14         | 1,173.12                       | 919.44           | 1,049.15          |
| Cost of second-line therapy                          | 815.05   | 994.19                     | 798.72           | 903.40                         | 1,136.92         | 1,189.75          |
| <b>2. Inpatient cost (All scenarios)</b>             |  |                            |                  |                                |                  |                   |
| <b>Annual per patient cost (Adults and children)</b> |  |                            |                  |                                |                  |                   |
|  | <b>Pre-ART</b>                                     |                            |                  | <b>ART</b>                     |                  |                   |
| >350 cells/microl                                    | Cost of first-line therapy during first six months |                            |                  | 451                            |                  |                   |
| 200-350 cells/microl                                 | Cost of first-line therapy after first six months  |                            |                  | 111                            |                  |                   |
| 50-199 cells/microl                                  | Cost of failed first-line therapy                  |                            |                  | 218                            |                  |                   |
| <50 cells/microl                                     | Cost of second-line therapy                        |                            |                  | 406                            |                  |                   |

We calculated total cost by multiplying the numbers of patients in each sub-population in each 6-month model cycle by the appropriate average 6-month unit cost, as Total cost = Number of patients in care \* Per patient cost. Deaths and losses were assumed to occur on average in the middle of the cycle and thus only incur 50% of the half-year unit cost in the cycle in which they occurred. All costs are undiscounted and presented in 2009 USD (1 ZAR = 0.1304 USD).

## 9.3 Results

### 9.3.1 Number of patients initiating ART and remaining in care

The total numbers of patients initiating ART between financial years 2010/11 and 2016/17 in the Old Guidelines, New Guidelines, and Full WHO Guidelines scenarios were 2.9 million, 3.3 million, and 3.6 million, respectively. In all three scenarios, the majority of patients were adults (89% with Early Paediatric

Treatment). In each scenario the number of patients alive and in care more than doubled over the seven years (Table 11). Table 2 in the Appendix gives the distribution of patients into antiretroviral drug regimens under each scenario.

**Table 11: Total number of patients on ART [thousands], 2010/11-2016/17**

| Scenario                   | Total number of patients initiated on ART (% change on Old Guidelines) | Total patients on ART (% change on Old Guidelines) |            |                    |
|----------------------------|--|--|------------|--------------------|
|                            |  | 2010   | 2016       | % change over time |
| <b>Old Guidelines</b>      | 2,928  | 1,333  | 3,061      | 130                |
| <b>New Guidelines</b>      | 3,334 (14)   | 1,409 (6)  | 3,491 (14) | 148                |
| <b>Full WHO Guidelines</b> | 3,596 (23)   | 1,655 (24)   | 3,855 (26) | 133                |

Figure 3 gives the distribution of adult patients into antiretroviral drug regimens under each scenario. While under the Old Guidelines, only four regimens are considered (including 3 first-line and only one second-line regimen), and the absolute majority of patients remains on d4T throughout the projection period, under both the New Guidelines and the Full WHO Guidelines d4T is being replaced by TDF as the most prescribed drug from the first year on due to a larger number of new initiates being eligible under these scenarios and initiated on TDF, and the single second-line regimen available under the Old Guidelines is complemented by two additional regimens, depending on the first-line regimen that is being replaced. (Note that the model somewhat underestimates AZT usage in first-line regimens, as only patients with severe renal failure under TDF are assumed to switch to AZT. In reality, some patients within the South African treatment programme are initiated on AZT.)

**Figure 3: Distribution of adult patients into antiretroviral regimens**

**A. Under the Old Guidelines**

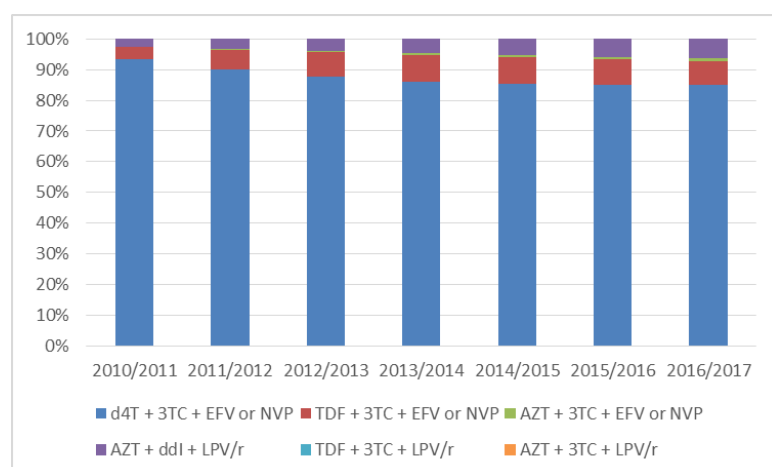

## B. Under the New Guidelines

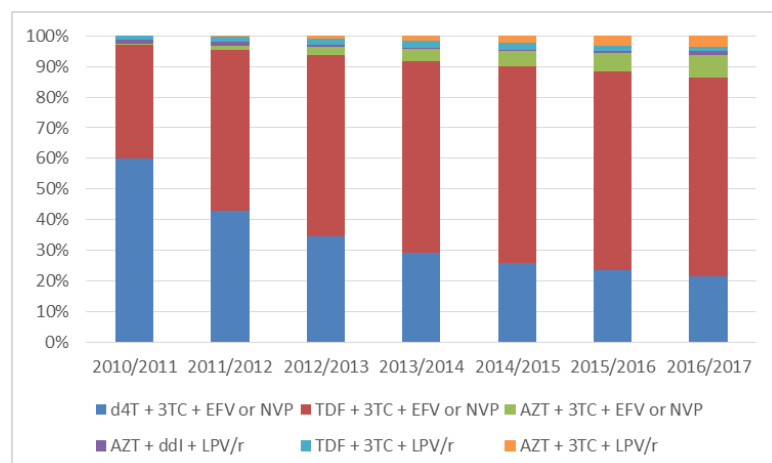

## C. Under the Full WHO Guidelines

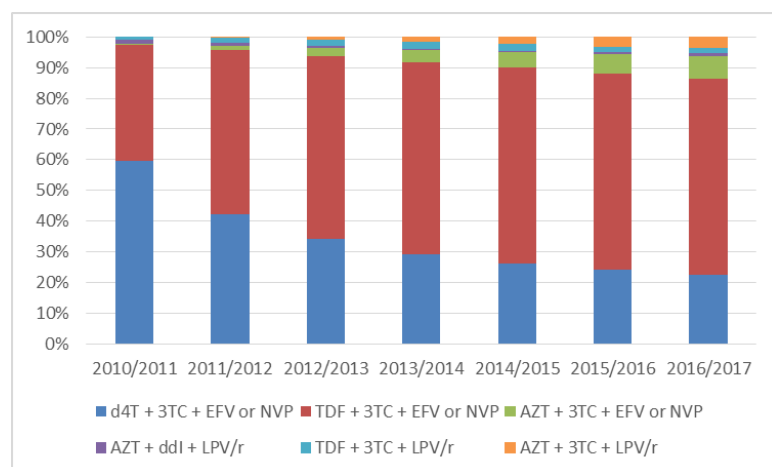

### 9.3.2 Total and average annual outpatient cost

The annual outpatient cost of the programme in 2010/11 was estimated to be USD 1.1 billion under the Old Guidelines, USD 1.3 billion under the New Guidelines, and USD 1.5 billion under the Full WHO Guidelines (Table 12). This cost was predicted to increase by 149%, 180%, and 164% by 2016/17 under each scenario, respectively. The percentage growth in cost was larger than the growth in number of patients for two reasons: increasing numbers of patients move to second-line ART over time; and, in the New Guidelines and Full WHO Guidelines scenarios, increasing numbers of patients were initiated on more expensive first-line regimens containing tenofovir and abacavir. As a result, average annual cost per patient in care increased from USD 856 to USD 929 under the Old Guidelines, from USD 885 to USD 999 under the New Guidelines, and from USD 882 to USD 1,000 under the Full WHO Guidelines.

**Table 12: Total outpatient cost by scenario, 2010/11-2016/17 [million 2009 USD]**

| Scenario                   | Full unit cost<br>(Staffing and drug cost as current)<br>(% change on Old Guidelines) |            |                       |             | Reduced unit cost<br>(with task-shifting and fixed-dose combinations)<br>(% change on Old Guidelines) |            |                       |             |                          |
|----------------------------|---|------------|-----------------------|-------------|---|------------|-----------------------|-------------|--------------------------|
|                            | 2010/11   | 2016/17    | % change<br>over time | Total       | 2010/11   | 2016/17    | % change<br>over time | Total       | % change<br>on Full cost |
| <b>Old Guidelines</b>      | 1,141   | 2,844      | 149                   | 14,095      | 631   | 1,563      | 148                   | 7,744       | -45                      |
| <b>New Guidelines</b>      | 1,247 (9)   | 3,486 (23) | 180                   | 16,751 (19) | 695 (10)  | 2,017 (29) | 190                   | 9,553 (23)  | -43                      |
| <b>Full WHO Guidelines</b> | 1,459 (28)  | 3,954 (36) | 164                   | 19,048 (35) | 809 (28)  | 2,220 (42) | 174                   | 10,804 (40) | -43                      |

The total cost of the national public-sector ART programme over seven years was USD 14.1 billion under the Old Guidelines, USD 16.8 billion under the New Guidelines, and USD 19.1 billion under the Full WHO Guidelines (Table 12). This amounted to a 19% increase in total cost over the Old Guidelines for the New Guidelines, and 35% for the Full WHO Guidelines. This means that the percentage increase in the cost of the programme as a result of increasing numbers in need of ART – an annual cost increase of 164% to 180% depending on the scenario – was significantly larger than the percentage increase caused by expanded eligibility or improved first-line drug choices, which was just 23% to 36% per year.

### 9.3.3 Cost savings from use of fixed-dose combinations and task-shifting

If antiretroviral drugs were accessed at current Clinton Foundation ceiling prices, and as fixed-dose combinations wherever possible, the total projected outpatient cost of the programme would decrease from the estimates presented above by 23%, 22%, and 22% under the Old Guidelines, New Guidelines, and Full WHO Guidelines scenarios, respectively. Task-shifting alone would reduce cost by a similar amount. If both the low-cost FDCs and task-shifting were combined, total cost would decrease by 45%, 43%, and 43%. In this case, the total cost of the ART programme under the New Guidelines would be 32% less than under the Old Guidelines without FDCs and task-shifting, while reaching 14% more patients. Implementing the Full WHO Guidelines would still be 23% less costly than continuing the Old Guidelines, while reaching 23% more patients (Table 12).

### 9.3.4 Inpatient cost

Inpatient cost is much smaller than outpatient cost, with total inpatient cost being between 5% and 6% of total outpatient cost in each scenario (Table 13). Because of this, even though inpatient cost increases somewhat under the New and Full WHO Guidelines (by 5 and 11%, respectively) as a result of the more frequent hospitalisations and longer length of stay experienced by patients on ART seen in Chapter 6, this is not enough to offset the large savings from the introduction of fixed-dose combinations and task-shifting into outpatient care.

**Table 13: Total inpatient cost by scenario, 2010/11-2016/17 [million 2009 USD]**

| Scenario                   | Full cost<br>(% change on Old Guidelines) |         |                       | Total    | % of total<br>outpatient<br>cost |
|----------------------------|---|---------|-----------------------|----------|----------------------------------|
|                            | 2010/11                                   | 2016/17 | % change<br>over time |          |                                  |
| <b>Old Guidelines</b>      | 82  | 136     | 66                    | 778      | 6                                |
| <b>New Guidelines</b>      | 84 (2)                                    | 142 (4) | 69                    | 814 (5)  | 5                                |
| <b>Full WHO Guidelines</b> | 93 (7)                                    | 146 (7) | 57                    | 860 (11) | 5                                |

### 9.3.5 Budget impact

The total government allocation for health in the 2010/11 South African Mid-Term Expenditure Framework was close to USD 13.9 billion, USD 15.0 billion, and USD 16.0 billion for the financial years 2010/11, 2011/12, and 2012/13, respectively [14]. Assuming these allocations would not increase, the total outpatient cost of the ART programme projected for these years would have required 8%, 9%, and 10% of the planned health budget under the Old Guidelines, 8%, 10%, and 12% under the New Guidelines, and 10%, 13%, and 15% under the Full WHO Guidelines. If the expected cost savings from Clinton Foundation ceiling prices and task-shifting had been achieved, the total cost of the programme would have equalled 5%, 6%, and 7% of the planned health budget under the Old Guidelines, 5%, 7%, and 8% under the New Guidelines, and 7%, 8%, and 10% under the Full WHO Guidelines.

## 9.4 Discussion

This study assessed the cost implications of adopting the 2009 WHO ART guidelines in the largest ART programme in the world. Our estimates suggested that for South Africa, adoption of the 2010 WHO guidelines would have increased per patient cost and far extended treatment eligibility, resulting in an increase of total programme cost by 36% over seven years.

We also describe the cost implications of the proposed new South African ART guidelines. The government increased the immunological ART eligibility threshold to a CD4 cell count of below 350 cells/microl for a subset of the population in need (i.e., patients who either have active TB or are pregnant). These two groups - pregnant women and TB patients - were singled out because they would likely benefit most in terms of preventing mortality and vertical transmission of HIV. Even with this limited change in eligibility, total cost was set to increase by 23% over the cost of keeping the old threshold of 200 CD4 cells/microl for all patients.

Under both scenarios the increase in cost was dwarfed by the increase in total cost resulting from the growth in the population in need of ART, regardless of eligibility criteria. HIV incidence and prevalence, in other words, will continue to be stronger drivers of treatment costs than eligibility thresholds or drug

choices. Our model indicated, however, that the projected increases in treatment cost under both scenarios could have been entirely offset by the introduction of cost-saving measures. If drugs were accessed at Clinton Foundation ceiling prices and task-shifting introduced, the incorporation of better first-line drugs and the increase in eligibility for both adults and children would become cost-neutral, regardless of whether the 350 cells/microl threshold is applied to all patients or only a subset.

Our analysis incorporates a number of innovations, the most important being the addition of time on treatment to the analysis of transition probabilities between health states for the majority of the model population, adults on first-line treatment. Our analysis of survival in care and CD4 cell count development for adults showed that transitions between CD4 cell count strata, mortality, and loss to follow up under first-line ART depend on time on ART as well as on the patient's current CD4 cell count. As a result we parametrised the model with transition matrices for adults on first-line ART stratified by time on ART as well as CD4 cell count category. This is the first health-state transition model of ART used for economic evaluations known to us that was parametrised in such detail, adding to the precision in estimating the numbers of people on ART and, hence, the total cost of the national ART programme.

There are a number of limitations to the study. Our model was set up to make maximum use of patient-level laboratory and outcome data, allowing us to extrapolate mortality, LTFU, and treatment failure at a high level of detail, while cost was differentiated by type of treatment and age group only and assumed to be uniform across CD4 cell counts and time on treatment. A limited number of studies suggest that per patient costs tend to be lower when ART is initiated at higher CD4 cell counts [15,16], which means that our results especially for the New Guidelines and Full WHO Guidelines scenarios might have been an overestimation. On the other hand, the assumption that under the Full WHO Guidelines scenario the rate of ART initiation amongst patients with CD4 cell counts between 200 and 350 cells/microl is only 30% of that of patients with CD4 cell counts below 200 cells/microl might have been too conservative, leading to an underestimation of the cost of this scenario. We also assumed that mortality, LTFU, and failure rates remain constant under any of the three scenarios and cost-saving measures. If the substitution of tenofovir for stavudine reduced loss to follow-up by reducing side effects, numbers of active patients and thus costs might have been higher under the New Guidelines and Full WHO Guidelines scenarios. Similarly, task-shifting of care from doctors to nurses could have resulted in better or worse patient outcomes, with corresponding consequences for total costs. Lastly, we did not include the potential impact of high-level population coverage with ART on HIV transmission which could ultimately reduce total treatment cost by reducing the number of patients becoming newly eligible [17,18], though the effect during our 7-year projection period would likely have been negligible.

Based in part on the results of our study, the National Department of Health in 2009 decided to change the national ART guidelines for both adults and children and considerably increase the funding available



to the programme. New guidelines announced in April 2010 increased the eligibility threshold to 350 CD4 cells/microl for patients with active TB and pregnant women, switched d4T to TDF for adults and to ABC for children for new patients, and introduced early paediatric treatment for all children less than 12 months with a positive PCR. In order to reach the target of 80% coverage of those in need of ART as quickly as possible, the ART budget within the 2010/11-2012/13 Medium-Term Expenditure Framework was increased by 90%, task-shifting was approved by government, and the number of accredited ART clinics was doubled. At the end of April 2010 the government embarked on a national HIV Counselling and Testing (HCT) campaign that aimed at testing 15 million South Africans, about a third of the country's population, by June 2011. The generation of the cost projections described here by the task team established by the Department helped convince the government that the country can afford to make these changes and thereby improve both the quality and reach of its HIV/AIDS programme.

## References

1. UNAIDS: AIDS epidemic update December 2009. Geneva 2009
2. Republic of South Africa: Country Progress Report on the Declaration of Commitment on HIV/AIDS. 2010 Report. Pretoria 2010
3. World Health Organization: Rapid advice: antiretroviral therapy for HIV infection in adults and adolescents. Geneva 2009
4. Johnson LF, Dorrington RE: Modelling the demographic impact of HIV/AIDS in South Africa and the likely impact of interventions. *Demogr Res* 2006;14: 541-74
5. Adam MA, Johnson LF: Estimation of adult antiretroviral treatment coverage in South Africa. *S Afr Med J* 2009;99(9):661-7
6. National Department of Health, Republic of South Africa: National Strategic Plan for HIV and AIDS & STIs 2007-2011. Pretoria 2007
7. Badri M, Wilson D, Wood R: Effect of highly active antiretroviral therapy on incidence of tuberculosis in South Africa: a cohort study. *Lancet* 2002;359:2059-64
8. Rollins NC, Coovadia HM, Bland RM, et al: Pregnancy outcomes in HIV-infected and uninfected women in rural and urban South Africa. *J Acquir Immune Defic Syndr*. 2007;44(3):321-8
9. Rosen S, Long L, Fox M, Sanne I: Cost and cost-effectiveness of switching from stavudine to tenofovir in first-line antiretroviral regimens in South Africa. *J Acquir Immune Defic Syndr* 2008;48(3):334-44.
10. Rosen S, Long L, Sanne I: The outcomes and outpatient costs of different models of antiretroviral treatment delivery in South Africa. *Trop Med Int Health* 2008;13(8):1005-15
11. Long L, Fox M, Sanne I, Rosen S: The high cost of second-line antiretroviral therapy for HIV/AIDS in South Africa. *AIDS* 2010;24(6):915-9
12. Reproductive Health and HIV Research Unit: Patient File Review Report, Tshepong Wellness Clinic, Klerksdorp, North West Province, South Africa. Internal Report, University of the Witwatersrand. Johannesburg 2008
13. Cleary S: The costs of the National Strategic Plan on HIV and AIDS & STIs 2007-2011. Cape Town 2007
14. National Treasury, Republic of South Africa: Budget Review 2010. Pretoria 2010
15. Leisegang R, Cleary S, Hislop M, et al: Early and late direct costs in a Southern African antiretroviral treatment programme: A retrospective cohort analysis. *PLoS Med* 2009 6(12)

16. Cleary S: Discussion – the economics of starting ART earlier. 5<sup>th</sup> International AIDS Society Conference 2009, Cape Town
17. Donnell D, Kiari J, Thomas K, et al: ART and Risk of Heterosexual HIV-1 Transmission in HIV-1 Serodiscordant African Couples: A Multinational Prospective Study. 17<sup>th</sup> Conference on Retroviruses and Opportunistic Infections 2010, Abstract 136
18. Granich RM, Gilks CF, Dye C, De Cock KM, Williams BG: Universal voluntary HIV testing with immediate antiretroviral therapy as a strategy for elimination of HIV transmission: a mathematical model. *Lancet* 2009;373(9657):48-57
19. Badri M, Cleary S, Maartens G, et al: When to initiate highly active antiretroviral therapy in sub-Saharan Africa? A South African cost-effectiveness study. *Antivir Ther* 2006;11(1):63-72
20. Walensky RP, Wolf LL, Wood R et al for the CEPAC (Cost-Effectiveness of Preventing AIDS Complications)-International Investigators: When to Start Antiretroviral Therapy in Resource-Limited Settings. *Ann Int Med* 2009;151:157-166
21. Nachega JB, Hislop M, Dowdy DW, et al: Adherence to Highly Active Antiretroviral Therapy Assessed by Pharmacy Claims Predicts Survival in HIV-Infected South African Adults. *J Acquir Immune Defic Syndr* 2006;43:78-84
22. Bolton-Moore C, Mubiana-Mbewe M, Cantrell RA, et al: Clinical outcomes and CD4 cell response in children receiving antiretroviral therapy at primary health care facilities in Zambia. *JAMA* 2007;298(16):1888-99
23. Greenland S, Robins JM: Empirical-Bayes adjustments for multiple comparisons are sometimes useful. *Epidemiology* 1991;2:244-51
24. Clinton Foundation Antiretroviral (ARV) Price List, version August 2009

## Appendix to chapter 9

NB, this appendix uses the same references as the main text of Chapter 9.

**Table 1: Probabilities of death, loss to follow-up, and treatment failure and transition probabilities between CD4 percentage-defined health states per 6-month cycle, by type of treatment and CD4 percentage stratum (Children)**

| First-line ART (Children < 12 months) |                   |                   |   |       |       |       |
|---------------------------------------|-------------------|-------------------|---|-------|-------|-------|
| Probability of                        |                   |                   | Probability of transition to CD4 % stratum: |       |       |       |
| Death                                 | Loss to follow-up | Treatment failure | <5  | 5-20  | 21-35 | >35   |
| if CD4 % >35                          |                   |                   |   |       |       |       |
| 7.1%                                  | 0%                | 0%                | 0%  | 0%    | 55.6% | 44.4% |
| if CD4 % 21-35                        |                   |                   |   |       |       |       |
| 2.3%                                  | 0.8%              | 0%                | 0.6%  | 14.3% | 80.0% | 5.7%  |
| if CD4 % 5-20                         |                   |                   |   |       |       |       |
| 5.2%                                  | 0%                | 0%                | 0%  | 43.8% | 49.3% | 6.9%  |
| if CD4 % <5                           |                   |                   |   |       |       |       |
| 15.6%                                 | 0%                | 0%                | 0%  | 70.0% | 30.0% | 0%    |

| First-line ART (Children 1 – 5 years)               |                   |                          |   |       |       |       |
|---|-------------------|--------------------------|---|-------|-------|-------|
| Probability of                                      |                   |                          | Probability of transition to CD4 % stratum: |       |       |       |
| Death   | Loss to follow-up | Treatment failure        | <5  | 5-20  | 21-35 | >35   |
| if CD4 % >35  |                   |                          |   |       |       |       |
| 2.0%  | 0.2%              | 0.9%                     | 0.3%  | 0.6%  | 32.2% | 66.9% |
| if CD4 % 21-35                                      |                   |                          |   |       |       |       |
| 0.5%  | 0.2%              | 1.0%                     | 0.1%  | 5.6%  | 78.8% | 15.4% |
| if CD4 % 5-20                                       |                   |                          |   |       |       |       |
| 0.2%  | 0.3%              | 0.5%                     | 0.7%  | 48.3% | 48.1% | 2.9%  |
| if CD4 % <5   |                   |                          |   |       |       |       |
| 0%  | 1.3%              | 0.5%                     | 15.2%                                       | 78.1% | 6.7%  | 0%    |
| First-line treatment failure (Children 1 – 5 years) |                   |                          |   |       |       |       |
| Probability of                                      |                   |                          | Probability of transition to CD4 % stratum: |       |       |       |
| Death   | Loss to follow-up | Switching to second line | <5  | 5-20  | 21-35 | >35   |
| if CD4 % >35  |                   |                          |   |       |       |       |
| 0.005%  | 0.005%            | 80%                      | 0%  | 0%    | 40.0% | 60.0% |
| if CD4 % 16-35                                      |                   |                          |   |       |       |       |
| 0.005%  | 0.005%            | 80%                      | 1.6%  | 10.9% | 79.7% | 7.8%  |
| if CD4 % 5-15                                       |                   |                          |   |       |       |       |
| 0.005%  | 0.005%            | 80%                      | 0%  | 70.8% | 29.2% | 0.0%  |
| if CD4 % <5   |                   |                          |   |       |       |       |
| 0.005%  | 0.005%            | 80%                      | 100.0%                                      | 0%    | 0%    | 0%    |

| First-line ART (Children 6 – 13 years)               |                   |   |   |       |        |       |
|--|-------------------|---|---|-------|--------|-------|
| Probability of                                       |                   |   | Probability of transition to CD4 % stratum: |       |        |       |
| Death  | Loss to follow-up | Treatment failure                           | <5  | 5-20  | 21-35  | >35   |
| if CD4 % >35   |                   |   |   |       |        |       |
| 0.2%   | 0.6%              | 0.8%  | 0%  | 0%    | 26.4%  | 73.6% |
| if CD4 % 16-35                                       |                   |   |   |       |        |       |
| 0.1%   | 0%                | 0.5%  | 0%  | 1.7%  | 90.5%  | 7.8%  |
| if CD4 % 5-15  |                   |   |   |       |        |       |
| 0.1%   | 0.5%              | 0.9%  | 1.0%  | 33.8% | 64.7%  | 0.6%  |
| if CD4 % <5  |                   |   |   |       |        |       |
| 1.5%   | 0.8%              | 1.0%  | 22.5%                                       | 62.8% | 14.2%  | 0.5%  |
| First-line treatment failure (Children 6 – 13 years) |                   |   |   |       |        |       |
| Probability of                                       |                   |   | Probability of transition to CD4 % stratum: |       |        |       |
| Death  | Loss to follow-up | Switching to second line                    | <5  | 5-20  | 21-35  | >35   |
| if CD4 % >35   |                   |   |   |       |        |       |
| 0%   | 0.005%            | 80%   | 0%  | 0%    | 26.7%  | 73.3% |
| if CD4 % 16-35                                       |                   |   |   |       |        |       |
| 0%   | 0.005%            | 80%   | 0%  | 3.6%  | 92.3%  | 4.1%  |
| if CD4 % 5-15  |                   |   |   |       |        |       |
| 0%   | 0.005%            | 80%   | 9.0%  | 61.2% | 29.9%  | 0.0%  |
| if CD4 % <5  |                   |   |   |       |        |       |
| 0%   | 0.005%            | 80%   | 16.7%                                       | 83.3% | 0%     | 0%    |
| Second-line ART (Children 6 – 13 years)              |                   |   |   |       |        |       |
| Probability of                                       |                   | Probability of transition to CD4 % stratum: |   |       |        |       |
| Death  | Loss to follow-up |   | <5  | 5-20  | 21-35  | >35   |
| if CD4 % >35   |                   |   |   |       |        |       |
| 0%   | 0.7%              |   | 0%  | 0%    | 100.0% | 0%    |
| if CD4 % 16-35                                       |                   |   |   |       |        |       |
| 0%   | 0.7%              |   | 0%  | 6.4%  | 87.2%  | 6.4%  |
| if CD4 % 5-15  |                   |   |   |       |        |       |
| 0%   | 0.7%              |   | 0%  | 66.7% | 33.3%  | 0%    |
| if CD4 % <5  |                   |   |   |       |        |       |
| 0%   | 0.7%              |   | 100.0%                                      | 0%    | 0%     | 0%    |

## Model equations

All transition probabilities and rates of mortality, loss to follow-up, treatment failure and coverage with second-line ART were combined to calculate the number of patients in each health state using the set of difference equations given below.

### Equation 1 (Patients on first-line ART):

$$\begin{aligned}
 I_{ART1(c+1)}(s,a,t+1) = & I_{ART1(c)}(s,a,t) + I_{n(c)}(s,a) * cr1(s,a,t) \\
 & - I_{ART1(c)}(s,a,t) * (m1(s,a,t) + l1(s,a,t) + tf(s,a,t) * (1-(tp_{h,h-x}(s,a,t) - tp_{h,h+x}(s,a,t)) * (1- ar(a_j))) \\
 & + I_{ART1(c)}(s_{h-x},a,t) * (m1(s_{h-x},a,t) + l1(s_{h-x},a,t) + tf(s_{h-x},a,t)) * tp_{h-x,h}(s_{h-x},a,t) \\
 & + I_{ART1(c)}(s_{h+x},a,t) * (m1(s_{h+x},a,t) + l1(s_{h+x},a,t) + tf(s_{h+x},a,t)) * tp_{h+x,h}(s_{h+x},a,t) \\
 & + I_{ART1(c)}(s_{h-x},a_{j-1},t) * (m1(s_{h-x},a_{j-1},t) + l1(s_{h-x},a_{j-1},t) + tf(s_{h-x},a_{j-1},t)) * tp_{h-x,h}(s_{h-x},a_{j-1},t) * ar(a_{j-1}) \\
 & + I_{ART1(c)}(s_{h+x},a_{j-1},t) * (m1(s_{h+x},a_{j-1},t) + l1(s_{h+x},a_{j-1},t) + tf(s_{h+x},a_{j-1},t)) * tp_{h+x,h}(s_{h+x},a_{j-1},t) * ar(a_j)
 \end{aligned}$$

with  $I_{ART1(c+1)}$  = Infected sub-population on first-line ART in cycle c+1  
 $I_n$  = Infected in need  
 $cr1$  = rate of coverage with first-line ART  
 $s$  = CD4 cell count/ percentage stratum  $h_{1,...,4}$   
 $a$  = age group  $j_{1,...,4}$   
 $t$  = time on treatment (half years)  
 $cr$  = coverage rate  
 $tf$  = rate of treatment failure development  
 $m$  = mortality rate  
 $l$  = rate of loss to follow up  
 $ar$  = aging rate  
 $tp$  = transition probability  
 $x = 1, \dots, 3$  (i.e., up to three health states higher or lower)

### Equation 2 (Patients in first-line treatment failure):

$$\begin{aligned}
 I_{TF(c+1)}(s,a,t+1) = & I_{TF(c)}(s,a,t) + I_{ART(c)}(s,a,t) * tf(s,a,t) \\
 & - I_{TF(c)}(s,a,t) * (m2(s,a,t) + l2(s,a,t) + cr2(s,a,t) * (1-(tp_{h,h-x}(s,a,t) - tp_{h,h+x}(s,a,t)) * (1- ar(a_j))) \\
 & + I_{TF(c)}(s_{h-x},a,t) * (m2(s_{h-x},a,t) + l2(s_{h-x},a,t) + cr2(s_{h-x},a,t)) * tp_{h-x,h}(s_{h-x},a,t) \\
 & + I_{TF(c)}(s_{h+x},a,t) * (m2(s_{h+x},a,t) + l2(s_{h+x},a,t) + cr2(s_{h+x},a,t)) * tp_{h+x,h}(s_{h+x},a,t) \\
 & + I_{TF(c)}(s_{h-x},a_{j-1},t) * (m2(s_{h-x},a_{j-1},t) + l2(s_{h-x},a_{j-1},t) + cr2(s_{h-x},a_{j-1},t)) * tp_{h-x,h}(s_{h-x},a_{j-1},t) * ar(a_{j-1}) \\
 & + I_{TF(c)}(s_{h+x},a_{j-1},t) * (m2(s_{h+x},a_{j-1},t) + l2(s_{h+x},a_{j-1},t) + cr2(s_{h+x},a_{j-1},t)) * tp_{h+x,h}(s_{h+x},a_{j-1},t) * ar(a_j)
 \end{aligned}$$

with  $I_{TF(c+1)}$  = Infected sub-population on first-line treatment failure in cycle c+1  
 $cr2$  = rate of coverage with second-line ART

**Equation 3 (Patients on second-line treatment):**

$$\begin{aligned} I_{ART2(c+1)}(s,a,t+1) = & I_{ART2(c)}(s,a,t) + I_{ART2(c)}(s,a,t) * cr2(s,a,t) \\ & - I_{ART2(c)}(s,a,t) * (m2(s,a,t) + l2(s,a,t) * (1-(tp_{h,h-x}(s,a,t) - tp_{h,h+x}(s,a,t)) * (1- ar(a_j))) \\ & + I_{ART2(c)}(s_{h-x},a,t) * (m2(s_{h-x},a,t) + l2(s_{h-x},a,t)) * tp_{h-x,h}(s_{h-x},a,t) \\ & + I_{ART2(c)}(s_{h+x},a,t) * (m2(s_{h+x},a,t) + l2(s_{h+x},a,t)) * tp_{h+x,h}(s_{h+x},a,t) \\ & + I_{ART2(c)}(s_{h-x},a_{j-1},t) * (m2(s_{h-x},a_{j-1},t) + l2(s_{h-x},a_{j-1},t)) * tp_{h-x,h}(s_{h-x},a_{j-1},t) * ar(a_{j-1}) \\ & + I_{ART2(c)}(s_{h+x},a_{j-1},t) * (m2(s_{h+x},a_{j-1},t) + l2(s_{h+x},a_{j-1},t)) * tp_{h+x,h}(s_{h+x},a_{j-1},t) * ar(a_j) \end{aligned}$$

with  $I_{ART2(c+1)}$  = Infected sub-population on 2<sup>nd</sup> line ART in cycle c+1

## 10 Cost benefit of workplace provision of ART

### The impact of company-level ART provision to a mining workforce in South Africa: A cost-benefit analysis

1. For a 'research paper' already published

- |  |                      |
|--|----------------------|
| 1.1. Where was the work published?                 | <b>PLoS Medicine</b> |
| 1.2. When was the work published?                  | <b>2015</b>          |
| 1.3. Was the work subject to academic peer review? | <b>Yes</b>           |
| 1.4. Have you retained the copyright for the work? | <b>Yes</b>           |

If yes, attach evidence of retention

**See first page of publication stating**

**the candidate being the copyright holder on next page**

If no, or if the work is being included in its published format, attach evidence of permission from copyright holder (publisher or other author) to include work

2. For a 'research paper' prepared for publication but not yet published

- 2.1. Where is the work intended to be published?
- 2.2. List the paper's authors in the intended authorship order
- Stage of publication – Not yet submitted/Submitted/Undergoing revision from peer reviewers' comments/In press

3. For multi-authored work, give full details of your role in the research included in the paper and in the preparation of the paper. (Attach a further sheet if necessary)

**The candidate built the model, analysed all data except the healthcare cost and absenteeism data, contributed to the stochastic fitting procedure and the probabilistic sensitivity analysis, and wrote the paper.**

Candidate's signature

Dr Gesine Meyer-Rath

Supervisor or senior author's signature to confirm role as stated in (3)

Dr Alec Miners

Supervisor

RESEARCH ARTICLE

# The Impact of Company-Level ART Provision to a Mining Workforce in South Africa: A Cost–Benefit Analysis

Gesine Meyer-Rath<sup>1,2,3\*</sup>, Jan Pienaar<sup>4</sup>, Brian Brink<sup>5</sup>, Andrew van Zyl<sup>6</sup>, Debbie Muirhead<sup>6</sup>, Alison Grant<sup>7</sup>, Gavin Churchyard<sup>6,7</sup>, Charlotte Watts<sup>8</sup>, Peter Vickerman<sup>9</sup>

**1** Department of Health Services Research and Policy, London School of Hygiene & Tropical Medicine, London, United Kingdom, **2** Center for Global Health and Development, Boston University, Boston, Massachusetts, United States of America, **3** Health Economics and Epidemiology Research Office, Department of Internal Medicine, Faculty of Health Sciences, University of the Witwatersrand, Johannesburg, South Africa, **4** Highveld Hospital, Anglo American Coal, Emalahleni, South Africa, **5** Anglo American, Johannesburg, South Africa, **6** The Aurum Institute, Johannesburg, South Africa, **7** Department of Clinical Research, London School of Hygiene & Tropical Medicine, London, United Kingdom, **8** Department of Global Health and Development, London School of Hygiene & Tropical Medicine, London, United Kingdom, **9** School of Social and Community Medicine, University of Bristol, Bristol, United Kingdom

\* [gesine@bu.edu](mailto:gesine@bu.edu)



CrossMark  
click for updates

 OPEN ACCESS

**Citation:** Meyer-Rath G, Pienaar J, Brink B, van Zyl A, Muirhead D, Grant A, et al. (2015) The Impact of Company-Level ART Provision to a Mining Workforce in South Africa: A Cost–Benefit Analysis. *PLoS Med* 12(9): e1001869. doi:10.1371/journal.pmed.1001869

**Academic Editor:** Joshua A. Salomon, Harvard School of Public Health, UNITED STATES

**Received:** August 15, 2014

**Accepted:** July 17, 2015

**Published:** September 1, 2015

**Copyright:** © 2015 Meyer-Rath et al. This is an open access article distributed under the terms of the [Creative Commons Attribution License](https://creativecommons.org/licenses/by/4.0/), which permits unrestricted use, distribution, and reproduction in any medium, provided the original author and source are credited.

**Data Availability Statement:** The fully parameterised model which incorporates all data and which was used to produce all projections within this paper can be downloaded from OpenBU via <http://hdl.handle.net/2144/10817>.

**Funding:** Funding for this study was obtained through a grant by GlaxoSmithKline to the Aurum Institute and direct funding from Anglo American. The funders had no role in study design, data collection and analysis, decision to publish, or preparation of the manuscript.

## Abstract

### Background

HIV impacts heavily on the operating costs of companies in sub-Saharan Africa, with many companies now providing antiretroviral therapy (ART) programmes in the workplace. A full cost–benefit analysis of workplace ART provision has not been conducted using primary data. We developed a dynamic health-state transition model to estimate the economic impact of HIV and the cost–benefit of ART provision in a mining company in South Africa between 2003 and 2022.

### Methods and Findings

A dynamic health-state transition model, called the Workplace Impact Model (WIM), was parameterised with workplace data on workforce size, composition, turnover, HIV incidence, and CD4 cell count development. Bottom-up cost analyses from the employer perspective supplied data on inpatient and outpatient resource utilisation and the costs of absenteeism and replacement of sick workers. The model was fitted to workforce HIV prevalence and separation data while incorporating parameter uncertainty; univariate sensitivity analyses were used to assess the robustness of the model findings. As ART coverage increases from 10% to 97% of eligible employees, increases in survival and retention of HIV-positive employees and associated reductions in absenteeism and benefit payments lead to cost savings compared to a scenario of no treatment provision, with the annual cost of HIV to the company decreasing by 5% (90% credibility interval [CrI] 2%–8%) and the mean cost per HIV-positive employee decreasing by 14% (90% CrI 7%–19%) by 2022. This translates into an average saving of US\$950,215 (90% CrI US\$220,879–US\$1.6 million)



## ***Preamble for paper 4***

The South African government is now for the first time calling for increased private sector involvement in the implementation and funding of HIV programs, after years of dramatically increasing domestic funding for the HIV/AIDS Conditional Grant in general, and in the ART budget in particular, between 2009/10 and 2014/15, based in part on the results of the National ART Cost Model, and in view of impending reductions in international donor contributions [1]. The rationale is that increasing HIV testing and treatment uptake at the workforce level could have benefits for both companies (if losses to productivity and workforce turnover are reduced, and less transmission to spouses and children occurs, in particular in companies paying for healthcare provision for both employers and their families) as well as society as a whole (by reducing morbidity and mortality due to HIV, and limiting the burden of ART provision on the public sector).

We conducted a cost-benefit analysis of the oldest and largest private-sector ART programme in the country, run by a coal mining company in a number of collieries in Mpumalanga since 2002. This is the first such analysis based on primary data that includes both the cost of the ART programme as well as its impact on worker absenteeism, turnover cost, and benefit payments. Due to detailed cost and impact data available from within the programme for both employees on and off ART, we were able to capture the full cost benefit of the ART programme compared to no ART - something that is hard to do in the public sector where records on HIV care before the advent of ART are sparse and incomplete due to the emergency nature of this care, in contrast to the more complete records involved in chronic care such as ART. We were also able to draw on unusually complete reporting of both inpatient and outpatient resource use since most care to employees is rendered at clinics and hospitals that are part of the mining compounds where miners work and live.

This analysis draws on an analysis of the cost of inpatient and outpatient HIV care and treatment by Debbie Muirhead and Andrew van Zyl as well as an analysis of employee absenteeism by Debbie Muirhead. A subset of the transition probabilities used in the Workplace Impact Model is based on data analysed by Dr Sue Ingle. The model was audited by Prof Peter Vickerman and Emma Beruter; the stochastic fitting procedure, probabilistic sensitivity analysis, and analysis of variance were added by Prof Peter Vickerman in collaboration with the candidate. All co-authors commented on and edited versions of the manuscript. All other work, including deciding on the analytical framework, developing and coding the model, analysing all other model inputs from the workforce data, and writing the first and consecutive drafts of the paper, was the candidate's.

## **References**

1. SANAC (South African National AIDS Council). 2011. National Strategic Plan on HIV, STIs and TB 2012–2016. Johannesburg, South Africa: Ed. Department of Health (DoH).

## **Paper 4**

### **The Impact of Company-Level ART Provision to a Mining Workforce in South Africa: A Cost–Benefit Analysis**

Gesine Meyer-Rath<sup>1,2,3\*</sup>, Jan Pienaar<sup>4</sup>, Brian Brink<sup>5</sup>, Andrew van Zyl<sup>6</sup>, Debbie Muirhead<sup>6</sup>, Alison Grant<sup>7</sup>, Gavin Churchyard<sup>6,7</sup>, Charlotte Watts<sup>8</sup>, Peter Vickerman<sup>9</sup>

<sup>1</sup> Department of Health Services Research and Policy, London School of Hygiene and Tropical Medicine, London, United Kingdom,

<sup>2</sup> Center for Global Health and Development, Boston University, Boston, Massachusetts, United States of America,

<sup>3</sup> Health Economics and Epidemiology Research Office, Department of Internal Medicine, Faculty of Health Sciences, University of the Witwatersrand, Johannesburg, South Africa,

<sup>4</sup> Highveld Hospital, Anglo American Coal, Emalahleni, South Africa,

<sup>5</sup> Anglo American, Johannesburg, South Africa,

<sup>6</sup> The Aurum Institute, Johannesburg, South Africa,

<sup>7</sup> Department of Clinical Research, London School of Hygiene and Tropical Medicine, London, United Kingdom,

<sup>8</sup> Department of Global Health and Development, London School of Hygiene and Tropical Medicine, London, United Kingdom,

<sup>9</sup> School of Social and Community Medicine, University of Bristol, Bristol, United Kingdom

\* [gesine@bu.edu](mailto:gesine@bu.edu)

**Abbreviations:** ART, antiretroviral therapy; HCT, HIV counselling and testing; USD, US dollars; VL, viral load

**Short title:** Cost–Benefit Analysis of Workplace ART in South Africa

#### **ABSTRACT**

**Background:** HIV impacts heavily on the operating costs of companies in sub-Saharan Africa, with many companies now providing antiretroviral therapy (ART) programmes in the workplace. A full cost–benefit analysis of workplace ART provision has not been conducted using primary data. We developed a dynamic health-state transition model to estimate the economic impact of HIV and the cost–benefit of ART provision in a mining company in South Africa between 2003 and 2022.

**Methods and Findings:** A dynamic health-state transition model, called the Workplace Impact Model (WIM), was parameterised with workplace data on workforce size, composition, turnover, HIV incidence, and CD4 cell count development. Bottom-up cost analyses from the employer perspective supplied data on inpatient and outpatient resource utilisation and the costs of absenteeism and replacement of sick workers. The model was fitted to workforce HIV prevalence and separation data while incorporating parameter uncertainty; univariate sensitivity analyses were used to assess the robustness of the model findings. As ART coverage increases from 10% to 97% of eligible employees, increases in survival and retention of HIV-positive employees and associated reductions in absenteeism and benefit payments lead to cost savings compared to a scenario of no treatment provision, with the annual cost of HIV to the company decreasing by 5% (5th to 95th percentile range 2%–8%) and the mean cost per HIV-positive employee decreasing by 14% (5th to 95th percentile range 7%–19%) by 2022. This translates into an average saving of US\$950,215 (5th to 95th percentile range US\$220,879–US\$1.6 million) per year; 80% of these cost savings are due to reductions in benefit payments and inpatient care costs. Although findings are sensitive to assumptions regarding incidence and absenteeism, ART is cost-saving under considerable parameter uncertainty and in all tested scenarios, including when prevalence is reduced to 1%—except when no benefits were paid out to employees leaving the workforce and when absenteeism rates were half of what data suggested. Scaling up ART further through a universal test and treat strategy doubles savings; incorporating ART for family members reduces savings but is still marginally cost-saving compared to no treatment. Our analysis was limited to the direct cost of HIV to companies and did not examine the impact of HIV prevention policies on the miners or their families, and a few model inputs were based on limited data, though in sensitivity analysis our results were found to be robust to changes to these inputs along plausible ranges.

**Conclusions:** Workplace ART provision can be cost-saving for companies in high HIV prevalence settings due to reductions in healthcare costs, absenteeism, and staff turnover. Company-sponsored HIV counselling and voluntary testing with ensuing treatment of all HIV-positive employees and family members should be implemented universally at workplaces in countries with high HIV prevalence.

## INTRODUCTION

HIV disease hits adults in the prime of their working lives. Companies therefore take a heavy toll in countries with high HIV prevalence [1,2]. To counter this, some companies provide their workforce with a number of HIV services, ranging from prevention activities to HIV testing and antiretroviral therapy (ART). While several companies in sub-Saharan Africa started ART programmes from 2002 onwards [3–5], quantifying these programmes' costs and benefits has proven difficult [3]. Even in sophisticated in-house medical programmes, longitudinal data collection is fraught with difficulty, and the relationship between

costs and benefits, such as regained productivity, can be hard to establish [3]. This makes it hard for companies to plan and budget for additional HIV-specific health programmes, and impossible to ascertain the programme's impact on the company's operations and profits.

HIV disease increases rates of absenteeism, labour force turnover, and, ultimately, the costs of company operations in sub-Saharan Africa. A number of studies have quantified the impact of HIV on labour forces in the region, with the cost of HIV ranging from 0.7% of wages [6] or 1% of labour cost [7] to 1%–9% of profits [8]. Only one study, amongst Kenyan tea pluckers, has estimated the impact of HIV on the productivity of a single worker, finding an 18% decrease in earnings in the year before termination amongst HIV-positive workers [9], in a setting where earnings are directly related to productivity.

South Africa is the sub-Saharan African country with the largest number of people living with HIV [10,11], with 18.8% of the working-age population (15–49 y old) being HIV infected [12]. In the last large-scale survey of 22 companies in South Africa, between 1999 and 2005, the workforce HIV prevalence in a non-representative sample averaged 11% [13], though estimates varied over time and between industries [3,13]. Similarly, the costs of HIV vary, with the estimated increase due to HIV in the cost of doing business (termed AIDS “tax” [1]) ranging from 0.4% to 5.9% of the annual wage bill of six South African companies in 2001 [1,2], or a 0.6%–10.8% increase in labour costs amongst companies from six countries in sub-Saharan Africa [3]. The cost per employee also varies considerably by skill level [2]. None of these studies, however, included the impact of workplace ART provision.

HIV care, including ART, has been provided by mining companies in South Africa since 2002, predating ART provision in the public sector [4,5]. While there are numerous estimates of the cost [14–27] and cost-effectiveness [28–45] of public sector ART provision in South Africa, the cost and impact of private sector ART provision at the workplace level have not yet been established. And while some aspects of this impact have been estimated in other countries, such as Kenya [46–50], Botswana [50], and Uganda [51], none of these estimates included productivity as well as healthcare costs, and none was a full cost–benefit analysis based on real-world programme data. In order to provide evidence for company management and policy-makers alike, we evaluated the impact and cost of both HIV and ART in a mining company in South Africa, and analysed the incremental cost–benefit balance of the company's ART programme compared to no ART provision.

## **METHODS**

### **Workplace under Study**

We report on the ART programme of a coal mining company operating at a number of collieries in Mpumalanga province since 2002. The programme is run from the mines' own clinics and hospitals and provides care for employees, contractors, and employees' dependants. Annual anonymous HIV counselling and testing (HCT) campaigns in the mines provide easy access to testing. HIV-positive

employees are enrolled in an HIV wellness programme that provides CD4 cell count testing every 3 months and interventions, such as isoniazid and cotrimoxazole prophylaxis, for the prevention and treatment of opportunistic infections. Employees were initiated on ART once their CD4 cell count was at or below 250 cells/mm<sup>3</sup> during the period 2003–2007, or at or below 350 cells/mm<sup>3</sup> during 2008–2010, or if presenting with WHO stage 3/4 disease, and their CD4 cell count and viral load (VL) were monitored twice annually thereafter. By the end of 2010, out of 9,252 employees, 1,149 had tested HIV positive in confirmatory tests and had been enrolled in the company's wellness programme. Since 2002, 629 employees have been initiated on ART, with 555 employees retained on ART by the end of 2010.

### **Model Description**

A dynamic Markov health-state transition model, the Workplace Impact Model (WIM), was developed to evaluate both the past and future impact and costs of introducing ART into the workforce from the perspective of the employer. The model is run twice, under a scenario of no ART provision (no ART scenario) and again under a scenario representing the scale-up of ART in the workforce (ART scenario). Both scenarios also include the cost and impact of other components of HIV healthcare such as HIV testing, wellness care, and other outpatient and inpatient care for HIV. The model projects the HIV-positive and -negative workforce over 20 years from 2003, taking into account planned changes to the workforce size as well as ageing and promotions. This time period is necessary to capture the full impact of the gradual scale-up of ART. The model calculates, in 3-month time steps, employees' HIV prevalence, their HIV test uptake and coverage with and loss from wellness and ART care, the number of employees leaving the workforce as a result of mortality and morbidity due to HIV (separations), the number of recruits to the workforce (some of which are HIV infected) that are required to offset this loss, the change in CD4 cell count (an indicator of immune system function) in HIV-positive employees, and the incremental costs of the ART programme itself, of additional outpatient and inpatient healthcare, and of absenteeism and workforce turnover (Fig. 1).

**Fig. 1. Population model of changes within the workforce.**

Recruits join the susceptible or infected (*I*) workforce depending on their HIV status at first employment. Employees move from the susceptible to the infected population according to prevalence and incidence. In the infected population, employees change between sub-populations representing different types of care (not tested, tested but not yet in care, wellness care, successful first- or second-line ART, and first-line or second-line treatment failure) according to coverage rates and, in case of treatment failure, to failure rates. Employees can drop out of care, i.e., be lost to retention, at any time and go back to the no care sub-population according to loss-to-retention rates; they can also leave the workforce for reasons related or unrelated to HIV (separations). Within each of the sub-populations, additional unidirectional changes due to ageing and promotion rates apply (not shown here); within each of the infected sub-populations, additional bi-directional changes due to transitions between CD4-cell-count-defined health states apply.

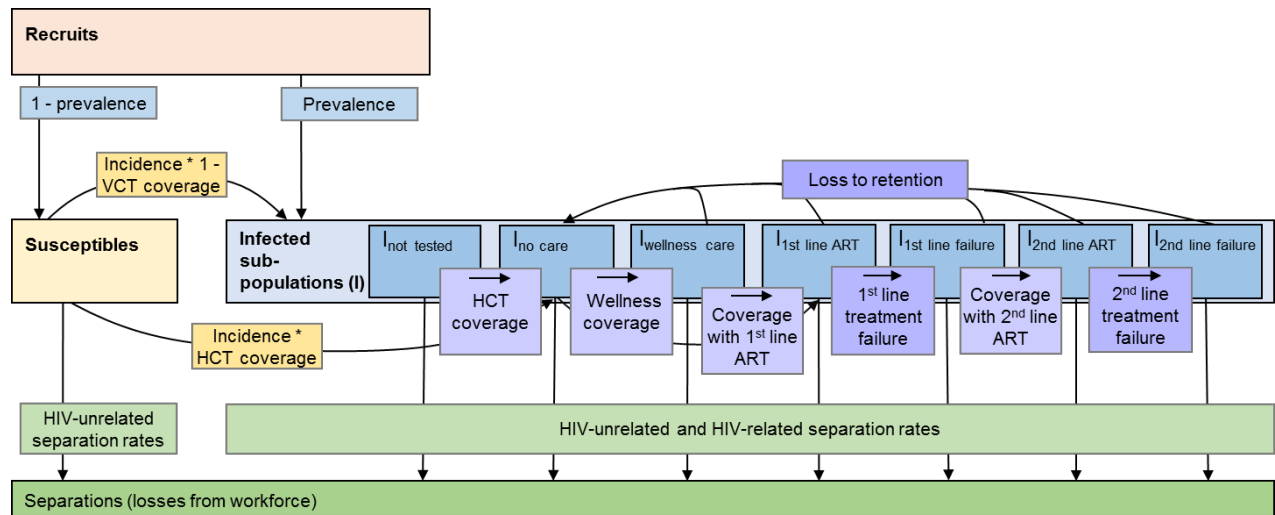

In order to capture important differences in survival and/or in healthcare and absenteeism costs, the HIV-infected workforce is divided into two genders, three age groups, six job grades, and five CD4-cell-count-defined health states, although not every parameter is differentiated by all four categories. Table 1 summarises the population categories used in the model; Table 2 gives more detail on the stratification levels.

**Table 1. Job grade, health state, and age group categories used in model**

| <b>Parameter</b>                                     | <b>Category</b>                   |
|--|-----------------------------------|
| <b>Patterson band<sup>1</sup></b>                    |                                   |
| A  | Job grade 1 (unskilled worker)    |
| B lower  | Job grade 2 (semi-skilled worker) |
| B upper  | Job grade 3 (semi-skilled worker) |
| C lower  | Job grade 4 (skilled worker)      |
| C upper  | Job grade 5 (skilled worker)      |
| D and E  | Job grade 6 (management)          |
| <b>CD4 cell count stratum (cells/mm<sup>3</sup>)</b> |                                   |
| >350   | Health state 1                    |
| 200–350  | Health state 2                    |
| 100–199  | Health state 3                    |
| 50–99  | Health state 4                    |
| <50  | Health state 5                    |
| <b>Age range (years)</b>                             |                                   |
| <30  | Age group 1                       |
| 30–50  | Age group 2                       |
| >50  | Age group 3                       |

<sup>1</sup>South African system of grading jobs according to the level of skill required for a certain job.

Due to the difficulty in capturing the programme’s benefit to dependants, this analysis is limited to employees. The model incorporates HIV incidence in the workforce but does not model HIV transmission from the workforce or the effect of ART on HIV transmission. Separations, i.e., losses to the workforce other than through retirement or retrenchment, most often due to ill-health or death, are differentiated into three categories (death, ill-health/disability, and other) in the model and are further differentiated by HIV status, job grade for HIV-negative employees, and CD4 cell count stratum for HIV-positive employees. More details on the methods used in estimating each parameter are given in Tables 2–4 and in Text S1, which also gives the model equations.

**Table 2. Details of parameter estimation, level of stratification, and data sources**

| Model Input or Assumption  | Level of Stratification                                | Source of Data (2003–2010)  | Method of Estimation   |  |
|--|--|---|--|--|
|  |  |   | 2003–2010 <sup>1</sup>   | 2011–2022                              |
| <b>1. Changes in workforce</b>   |  |   |  |  |
| Workforce needed at end of year  | Job grade, year  | Company data  | Data taken as is to calculate number of recruits or retrenchments required   | Assumed to remain same as in 2010      |
| Number of recruits   | Job grade, year  |   | Set to produce workforce needed at end of year   | Same as for 2003–2010                  |
| Prevalence of recruits/retrenchees <sup>2</sup>  | Job grade, gender, year (for retrenchees, also by age) | Company data  | N: all new employees with a positive first HIV result in the year of recruitment; D: all new employees with a positive or negative first HIV result in the year of recruitment | Assumed to remain same as in 2010      |
| Distribution of recruits   | Age group, gender, year                                | Company data (distribution set to be same as workforce distribution in database in 2003–2010) | N: number of employees in database by year, job grade, gender, and age group; D: total number of employees across all job grades, age groups, and genders by year              | Assumed same as average 2003–2010      |
| Annual rate of promotion   | Job grade, year  | Company data for 2005/2006  | Assumed to remain same as in 2005/2006   | Assumed to remain same as in 2005/2006 |
| <b>2. Start population and coverage</b>  |  |   |  |  |
| Distribution of start population (all employees)   | Age group, gender, job grade                           | Company data  | Number of employees in database by 31 Dec 2002 by job grade, gender, and age group   | N/A (start year only)                  |
| HIV status of start population (all employees)   | HIV status of those employees with an HIV test         | Company data  | Number of HIV-positive employees tested before 31 Dec 2002 and assumptions regarding untested employees' HIV status  | N/A (start year only)                  |
| Distribution of start population into CD4 cell count categories (HIV-positive employees) | CD4 cell count category                                | No data   | Same proportion assumed in each CD4 cell count strata  | N/A (start year only)                  |



| Model Input or Assumption  | Level of Stratification  | Source of Data (2003–2010)                         | Method of Estimation  |                                      |
|--|--|--|---|--------------------------------------|
|  |  |  | 2003–2010 <sup>1</sup>  | 2011–2022                            |
| Baseline HCT coverage <sup>3</sup>   | Age group, gender, job grade                                       | Company data                                       | Number of employees tested before 31 Dec 2002 by job grade, gender, and age group   | N/A (start year only)                |
| <b>3. Costs</b>  |  |  |   |                                      |
| Average basic salary   | Job grade  | Company data (payroll)                             | Salaries in cost year (2006)  | Real cost assumed constant over time |
| Incremental replacement cost for HIV-positive employees                              | Job grade  | Interviews with company human resources department | Average cost per new employee by job grade in cost year (2006)  | Real cost assumed constant over time |
| Number of years that benefits get paid   | None   | Company benefit policy                             | Company policy  | Real cost assumed constant over time |
| Incremental inpatient/outpatient cost for HIV-positive employees in cost year (2006) | Type of care (ART/no ART), CD4 cell count category                 | Bottom-up cost analysis of company health services | Average cost per employee in cost year (2006); includes non-ARV drugs, non-ARV-specific laboratory tests, patient contact time, other medical supplies, site programme cost, but no central management cost | Real cost assumed constant over time |
| Annual per employee cost of ART in cost year (2006)                                  | CD4 cell count category  | Bottom-up cost analysis of company health services | Average cost per employee in cost year (2006); includes central management cost for ART programme, ARV drug cost, ART-specific laboratory tests (CD4, VL)   | Real cost assumed constant over time |
| Incremental absenteeism cost for HIV-positive employees                              | Type of care (ART/no ART only), CD4 cell count category, job grade | Payroll data on sick leave days                    | Absent days/shifts lost to sickness (sick leave) by health state in cost year (2006) multiplied by job-grade-specific salary per day/shift  | Real cost assumed constant over time |
| <b>4. Transitions between CD4 cell count categories</b>                              |  |  |   |                                      |

| Model Input or Assumption  | Level of Stratification                                       | Source of Data (2003–2010)  | Method of Estimation   |   |
|--|---|---|--|---|
|  |   |   | 2003–2010 <sup>1</sup>   | 2011–2022   |
| Transition probabilities   | Type of care, CD4 cell count category                         | No care: public sector data based on [52]; all else: company data   | N: all employees with a CD4 cell count in one stratum in time period $t$ who have a CD4 cell count in a different stratum in time period $t + 1$ ; D: all employees with a CD4 cell count in one stratum in time period $t$ that also had a CD4 cell count in time period $t + 1$  | Assumed constant over time  |
| Transition probabilities   | Type of care, CD4 cell count category                         | No care: public sector data based on [52]; all else: company data   | N: all employees with a CD4 cell count in one stratum in time period $t$ who have a CD4 cell count in a different stratum in time period $t + 1$ ; D: all employees with a CD4 cell count in one stratum in time period $t$ that also had a CD4 cell count in time period $t + 1$  | Assumed constant over time  |
| <b>5. HIV incidence; coverage with testing, care, and ART; and treatment failure and retention</b> |   |   |  |   |
| Incidence  | Job grade, CD4 cell count category <sup>4</sup> , year        | Change in HIV incidence over time fitted to company data on HIV incidence [53]; job grade weights: company data; CD4 cell count category weights: assumed | HIV seroconversion was assumed to occur at the midpoint between the first positive and the last previous negative HIV test; N: all employees with a calculated seroconversion date in one year; D: all employees with a negative HIV result and no seroconversion date in the previous year. This analysis excludes employees whose HIV test result was given as “unknown” | Assumed same as average of 2008–2010  |
| Coverage with HIV testing, wellness care, and ART  | Type of care, year, and for ART, also CD4 cell count category | Company data  | Model fitted to reported proportions of HIV-positive employees in each type of care  | Assumed same as average of 2008–2010, except transition to first-line ART from wellness care, which is used to achieve ~92% ART coverage of eligible population |

| Model Input or Assumption | Level of Stratification                    | Source of Data (2003–2010) | Method of Estimation  |                                      |
|---------------------------|--|----------------------------|---|--------------------------------------|
|                           |  |                            | 2003–2010 <sup>1</sup>  | 2011–2022                            |
| Rate of treatment failure | Year (same for first- and second-line ART) | Company data               | N: employees with a failure start date during time period <i>t</i> ; D: all employees on ART at the beginning of time period <i>t</i>   | Assumed same as average of 2008–2010 |
| Loss-to-follow-up rate    | Type of care, year                         | Company data               | N: all employees with a care stop date (wellness care and ART only) during time period <i>t</i> ; D: all employees in wellness care and ART, respectively, at the beginning of time period <i>t</i> | Assumed same as average of 2008–2010 |

#### 6. Separation rates

|               |   |              |  |                            |
|---------------|---|--------------|--|----------------------------|
| HIV-related   | Type of separation, CD4 cell count category | Company data | Ill-health, death, and other non-transfer separations were allocated to a CD4 cell count category using the last available CD4 cell count before exit from the workforce from the database; N: all HIV-positive employees with an employment stop date by separation category and CD4 cell count category; D: all employee-years in the same CD4 cell count category | Assumed constant over time |
| HIV-unrelated | Type of separation, job grade               | Company data | N: all HIV-negative employees with an employment stop date by separation category and job grade; D: all employee-years in the same job grade   | Assumed constant over time |

“Company data” refers to the mine company’s employee database of 9,211 employees and a separate database documenting the 1,149 employees who tested HIV positive and were enrolled in the company’s HIV care programme. The databases cover the period January 2003 to December 2010.

<sup>1</sup>Details of analysis are given if a parameter was analysed from the company’s employee database. D, denominator; N, numerator.

<sup>2</sup>If the workforce is set to be reduced during one year, the resulting number of recruits will be negative, signifying the number of people who will be retrenched, rather than recruited, during that year.

<sup>3</sup>Coverage with all other care is set to zero at baseline.

<sup>4</sup>Incidence is stratified by CD4 cell count category to allow the distribution of newly incident members of the infected population into CD4 cell count categories. The values of the weights are 0.1, 0.2, 0.3, 0.5, and 1 for the categories >350, 200–350, 100–199, 50–99, and <50 cells/mm<sup>3</sup>, respectively.

ARV, antiretroviral; N/A, not applicable.

**Table 3. Values and sources of main model inputs and assumptions**

| Parameter   | Value by Job Grade |        |        |        |        |         | Total | Source  |
|---|--------------------|--------|--------|--------|--------|---------|-------|---|
|   | 1                  | 2      | 3      | 4      | 5      | 6       |       |   |
| <b>Workforce needed at end of year</b>                                      |                    |        |        |        |        |         |       |   |
| 2003  | 133                | 857    | 2,251  | 954    | 673    | 379     | 5,247 | Business plans from human resource managers   |
| 2004  | 128                | 858    | 2,250  | 1,122  | 695    | 400     | 5,453 |   |
| 2005  | 137                | 894    | 2,282  | 1,276  | 743    | 450     | 5,782 |   |
| 2006  | 152                | 982    | 2,326  | 1,534  | 798    | 507     | 6,300 |   |
| 2007  | 247                | 1,069  | 2,348  | 1,749  | 875    | 591     | 6,879 |   |
| 2008  | 324                | 1,243  | 2,590  | 2,105  | 986    | 722     | 7,969 |   |
| 2009  | 451                | 1,386  | 2,776  | 2,356  | 1,086  | 820     | 8,875 |   |
| 2010 and onwards  | 705                | 1,433  | 2,772  | 2,405  | 1,119  | 818     | 9,252 |   |
| <b>Salaries and benefits in 2010 US dollars</b>                             |                    |        |        |        |        |         |       |   |
| Average annual basic salary   | 10,047             | 12,043 | 16,057 | 20,740 | 25,925 | 54,242  | —     | Human resource data   |
| Employee benefits (ill-health and death benefit: three times annual salary) | 30,141             | 36,128 | 48,171 | 62,220 | 77,775 | 162,726 | —     | Interviews with pension and provident fund administrators, document review, and claims data |
| Recruitment and training cost per new recruit                               | 55,096             | 55,096 | 55,096 | 55,096 | 55,096 | 84,133  | —     | Human resource data   |
| <b>HIV-unrelated separations (percent of workforce leaving per year)</b>    |                    |        |        |        |        |         |       |   |
| Disability/ill-health   | 0.66%              | 0.08%  | 0.21%  | 0.24%  | 0.09%  | 0.03%   | —     | Workforce data  |
| Death   | 0.99%              | 0.21%  | 0.57%  | 0.35%  | 0.28%  | 0.26%   | —     |   |
| Other <sup>1</sup>  | 5.63%              | 1.50%  | 1.78%  | 8.53%  | 4.79%  | 5.92%   | —     |   |

**Table 4. Values and sources of main model inputs and assumptions (HIV-related separations only)**

| HIV-Related Separations (Incremental to HIV-Unrelated Separations) | CD4 Cell Count (cells/mm <sup>3</sup> ) |         |         |        |        |
|--|---|---------|---------|--------|--------|
|  | >350                                    | 200–350 | 100–199 | 50–99  | <50    |
| Disability/ill-health  | 1.20%                                   | 1.80%   | 2.10%   | 2.70%  | 14.00% |
| Death  | 3.00%                                   | 4.70%   | 9.20%   | 24.80% | 67.10% |
| Other <sup>1</sup>   | 6.90%                                   | 8.20%   | 8.60%   | 9.00%  | 12.90% |

Source: workforce data.

<sup>1</sup>Other separations include dismissals in absentia.  
USD, US dollars.

### Model Parameterisation

The model was parameterised with company data on the size, composition, and turnover of the workforce at the mines obtained from the company employee database of 9,211 employees, covering the period January 2003 to December 2010 and including job grade, gender, engagement and termination dates, and the coverage and results of the serial HCT campaigns. Annual coverage with linked workplace HCT campaigns increased from 40% of all employees in 2003 to 86% in 2008, enabling a reliable estimation of HIV incidence in later years. A separate database documenting the 1,149 employees who tested HIV positive and were enrolled in the company's HIV care programme over the same period of time provided

inputs regarding coverage of wellness care and ART, retention in care, development of treatment failure, and employees' CD4 cell counts over time. The two databases were anonymously linked for this analysis.

We parameterised the model with annual HCT and ART coverage, HIV prevalence in new employees joining the workforce, as well as the incidence of treatment failure and loss to retention in the programme as reported in these databases. Based on these data, HCT coverage was set to reach 92% by 2010 and to remain constant thereafter. The HCT data were also used to estimate the HIV incidence and prevalence amongst all employees. Incidence was estimated for those employees with two or more HIV tests, with HIV conversion assumed to be at the midpoint between the first positive and the last prior negative HIV test [53]. These data suggested that HIV incidence varied between 1.2 and 2.6 per 100 employee-years in the workforce throughout and that prevalence increased from 11% in 2005 to 16% in 2010. ART coverage of those eligible was calibrated to increase from 11% in 2003 to 68% in 2010, as suggested by the workforce data, and was modelled to reach 88% by 2013 and 100% by 2022. First-line treatment failure was set to vary between 8% and 11% per year, and loss to follow-up between 6% and 12% per year, likely including some migration to ART programmes outside the workforce. The values of important model parameters are summarised in Tables 3 and 4; the remainder of the parameters and their 95% confidence intervals are available in Text S1.

### **Transition Probabilities**

A detailed electronic register including the results of all CD4 cell count measurements (every 3 mo) from all HIV-positive employees for the same period as the workforce database (January 2003–December 2010) was used to estimate the transition probabilities between CD4-cell-count-defined health states for the wellness care and ART populations (Table 5). The database contained a total of 10,972 CD4 cell count test results, with a mean patient follow-up of 961 d (maximum 2,822 d). Since almost all employees who test HIV positive in the workplace testing programme immediately enter care, we used historic data from the South African public sector to parameterise the transitions for the undiagnosed and no care populations [52]. Because of insufficient data, these transitions were also applied to the treatment failure population.

**Table 5. Model 3-mo transition probabilities between CD4-cell-count-defined health states by type of care**

| Ending CD4 Cell Count<br>(cells/mm <sup>3</sup> ) | Starting CD4 Cell Count (cells/mm <sup>3</sup> ) |         |         |       |      | Source         |
|---|--|---------|---------|-------|------|----------------|
|   | >350   | 200–350 | 100–199 | 50–99 | <50  |                |
| <b>Untested, no care, or treatment failure</b>    |  |         |         |       |      |                |
| >350  | 0.94   | 0       | 0       | 0     | 0    | [52]           |
| 200–350   | 0.05   | 0.92    | 0       | 0     | 0    |                |
| 100–199   | 0.01   | 0.06    | 0.94    | 0     | 0    |                |
| 50–99   | 0.001  | 0.01    | 0.04    | 0.91  | 0    |                |
| <50   | 0.002  | 0.01    | 0.02    | 0.09  | 1.00 |                |
| <b>Wellness care</b>                              |  |         |         |       |      |                |
| >350  | 0.86   | 0.16    | 0.01    | 0     | 0    | Workforce data |
| 200–350   | 0.13   | 0.71    | 0.23    | 0.05  | 0.07 |                |
| 100–199   | 0.01   | 0.12    | 0.59    | 0.20  | 0.07 |                |
| 50–99   | 0  | 0       | 0.14    | 0.55  | 0.14 |                |
| <50   | 0  | 0       | 0.04    | 0.20  | 0.71 |                |
| <b>First- and second-line ART</b>                 |  |         |         |       |      |                |
| >350  | 0.93   | 0.21    | 0.02    | 0     | 0.17 | Workforce data |
| 200–350   | 0.07   | 0.74    | 0.28    | 0.03  | 0    |                |
| 100–199   | 0  | 0.05    | 0.69    | 0.41  | 0.33 |                |
| 50–99   | 0  | 0       | 0.02    | 0.47  | 0.17 |                |
| <50   | 0  | 0       | 0       | 0.09  | 0.33 |                |

Each employee's available CD4 cell count data were allocated to each type of care in 3-mo time periods from the start date for this type of care up until the time period including the stop date for this type of care. If CD4 cell counts were missing for one or two consecutive time periods, they were linearly interpolated from the CD4 cell counts of the two adjacent time periods. These CD4 cell counts were then allocated to five different CD4 cell count strata, which in turn defined the model health states (see Table 1).

For the calculation of transition probabilities, in order to differentiate between patients in wellness care and those accessing ART outside the company healthcare system, CD4 cell counts were considered to be wellness care CD4 cell counts only if any VL measured during the same 3-mo time period was unsuppressed (>50 copies/ml). If a suppressed VL count was found before the date of ART initiation in the workforce programme, the patient was deleted from the wellness care CD4 analysis. In order to exclude patients in treatment failure, CD4 cell counts were considered to be ART CD4 cell counts only if any VL measured during the same time period was suppressed (≤50 copies/ml), though the patient could still contribute other (i.e., earlier or later) CD4 cell counts to the ART CD4 population if they coincided with a suppressed VL.

### Cost Data

A bottom-up patient-level analysis of economic costs from the employer perspective was conducted in 2006 to quantify all costs of HIV/AIDS to the company. The analysis, which has been described in detail

elsewhere [54,55], included the cost of the ART programme, including the cost of antiretroviral drugs, ART-specific laboratory tests such as CD4 cell count and VL, and management and training costs within and above the facility level, as well as any other HIV-related cost such as inpatient and outpatient resource utilisation and costs, and the costs of absenteeism and replacing a sick or deceased worker, including the benefits paid to the worker or his/her family and the costs of recruiting and training a replacement. Healthcare resource use, quantified as the number of inpatient days and outpatient visits, was abstracted from record systems at the company health centres and averaged by CD4 cell count stratum, based on the employee's most recent CD4 cell count. Absenteeism was calculated as the median number of days of sick leave of patients in wellness care and on ART by CD4 cell count stratum, based on the company's payroll data. Both healthcare and absenteeism costs were calculated incrementally to that of HIV-negative employees.

Due to the choice of an employer perspective, costs to the employee and the broader society were excluded, but since most employees of the mining company seek care at the workplace clinics and hospitals, resource use captured for this analysis is unusually complete. Cost inputs are summarised in Table 6. Cost data were collected in South African rands (ZAR) during 2006/2007, adjusted for inflation to 2010, and converted to US dollars (USD) using the 2010 average conversion rate of 8 ZAR/1 USD (Text S1 contains an explanation of the time period for inflation adjustment). Costs are presented undiscounted and discounted at 5% per annum, the repurchase rate of the South African Reserve Bank during most of the analysis period [56].

**Table 6. Annual per employee cost and frequency of absenteeism by CD4 cell count category, incremental to that of HIV-negative employees**

| Parameter                         | Items Included   | Cost in 2010 USD by CD4 Cell Count |                                  |                                  |                                |                              |
|-----------------------------------|--|------------------------------------|----------------------------------|----------------------------------|--------------------------------|------------------------------|
|                                   |  | >350<br>Cells/mm <sup>3</sup>      | 200–350<br>Cells/mm <sup>3</sup> | 100–199<br>Cells/mm <sup>3</sup> | 50–99<br>Cells/mm <sup>3</sup> | <50<br>Cells/mm <sup>3</sup> |
| <b>Medical care</b>               |  |                                    |                                  |                                  |                                |                              |
| <i><b>Patients not on ART</b></i> |  |                                    |                                  |                                  |                                |                              |
| Inpatient care                    | Mean cost of inpatient care per year   | 335                                | 425                              | 557                              | 1,832                          | 1,153                        |
| Outpatient care                   | Mean cost of outpatient care per year  | 164                                | 152                              | 157                              | 129                            | 250                          |
| <i><b>Patients on ART</b></i>     |  |                                    |                                  |                                  |                                |                              |
| Inpatient care                    | Mean cost of inpatient care per year   | 222                                | 133                              | 219                              | 303                            | 1,166                        |
| Outpatient care                   | Mean cost of outpatient care per year  | 122                                | 124                              | 120                              | 124                            | 147                          |
| ART (first and second line)       | Drugs, laboratory tests, other medical supplies, staff time, site programme cost, and central management cost per year | 1,826                              | 1,826                            | 1,826                            | 1,826                          | 1,826                        |
| <b>Absenteeism</b>                |  |                                    |                                  |                                  |                                |                              |

|                                   |   |    |    |    |    |    |
|-----------------------------------|---|----|----|----|----|----|
| <b><i>Patients not on ART</i></b> | Median days absent due to sickness per year | 18 | 15 | 24 | 39 | 55 |
| <b><i>Patients on ART</i></b>     | Median days absent due to sickness per year | 11 | 13 | 16 | 23 | 55 |

### **Model Calibration and Sensitivity Analysis**

Because sampling uncertainty surrounds many of the important model parameters, we defined probability distributions around the main inputs, with the distributions based on the primary workforce, absenteeism, and cost data used in this analysis. Some parameters were also stratified by CD4 cell count or job grade (separation rates) or were time dependent (treatment failure probability). Statistical distributions were assigned to these parameters based on standard practice in economic evaluations [57], with specific details included in Text S1.

To calibrate the model while accounting for this sampling uncertainty, 20,000 parameter sets were randomly sampled (using Latin hypercube sampling) from the parameter distributions, and the resulting model runs were compared to see if they fit within the uncertainty range for the observed HIV prevalence of the workforce in 2010 (12.8%–19.2%) and the average annual number of separations in HIV-positive (50–150) and HIV-negative (200–500) employees during 2005–2009. The 998 model runs that fit these data were then used to assess the uncertainty around our main outcomes (total costs, cost savings, and HIV prevalence), with medians and 5th to 95th percentile ranges being produced for each outcome. In addition, an analysis of co-variance was undertaken to quantify the contribution of different parameters to the uncertainty in the projected undiscounted savings due to ART.

Additionally, we undertook univariate sensitivity analyses on selected parameters, examining the impact of the following: reducing all absenteeism by half; assuming the same absenteeism on ART as off ART; assuming the same ART cost and health-state transition probabilities as found in analyses of public sector ART provision in South Africa using similar methodology [58,59]; changing inpatient and outpatient costs by  $\pm 50\%$  (note that in each instance only the extremes of the range were considered); changing the number of annual salary equivalents paid out as benefits to 0, 1, or 2 y instead of 3; changing HIV-dependent separation rates by  $\pm 20\%$ ; changing incidence by  $\pm 50\%$ ; and, in order to examine the generalisability of results to a setting with low HIV prevalence, reducing incidence to an extremely low value of 0.0001 and prevalence in the start population and amongst new recruits each to a tenth of the baseline values. For each of these sensitivity analyses, the effect of the parameter change was evaluated on all the baseline model fits so that an average effect could be estimated.

Lastly, in order to analyse the future impact of changes in treatment policies, we parameterised the model for two additional scenarios to be implemented from 2013 onwards. First, we considered a universal test and treat scenario in which HCT coverage was 100% each year, and 100% of employees who tested HIV-positive initiated ART within 6 mo, regardless of CD4 cell count or clinical status. We conservatively assumed no impact of this high-level ART coverage on HIV incidence since the intervention would cover



only employees and not their sexual partners. In a second scenario (“family treatment”), we incorporated the extension of ART to those family members of employees who were eligible for ART, with an assumed average of one ART-eligible dependant per HIV-positive employee on ART.

### **Ethics Approval**

The study was reviewed and approved by the following ethics committees: the London School of Hygiene and Tropical Medicine Ethics Committee (application number 962), the Anglogold Health Service Research Ethics Committee (AHS REC 004/02), and the University of KwaZulu-Natal Biomedical Research Ethics Committee (BE093/08). Employees’ consent to participation in this study was waived as we used only data that were collected for routine care purposes and, as in most other routine care settings, employees did not give written consent for this care.

### **Data Availability**

The fully parameterised model that incorporates all data and that was used to produce all projections within this paper can be downloaded from OpenBU via <http://hdl.handle.net/2144/10817>.

## **RESULTS**

### **Patient-Level Cost and Resource Use and Absenteeism of Employees on and off ART**

The results of our bottom-up cost analyses in HIV-positive employees show that regardless of ART status, average annual outpatient and inpatient employee costs both increase with decreasing CD4 cell count, and, in contrast to analyses of the cost of public sector ART provision in South Africa [26–29], inpatient costs are higher than outpatient costs per patient-year (Table 6). Once employees initiate ART, these costs of care decrease dramatically across all CD4 cell count strata. However, when considering the healthcare cost of the HIV programme only, and excluding other HIV-related costs such as absenteeism and the cost of staff turnover, the addition of ART renders the HIV programme more expensive than without ART.

HIV-positive employees not on ART have between 11 and 40 sick leave days annually over and above the average number of sick leave days in HIV-negative employees (Table 6). For specific CD4 strata, the level of absenteeism decreases by 16%–42% after ART initiation, except in employees with a CD4 cell count of <50 cells/mm<sup>3</sup>. As with healthcare costs, the most absenteeism is seen in the lowest CD4 cell count stratum, whether on or off ART.

## Coverage with Care, Survival in Employment, and HIV Prevalence

Fig. 2 shows the distribution of employees into types of care over the model projection period. While the proportion of untested HIV-positive employees falls with increasing HCT coverage, the proportion in wellness care first increases and then drops slightly as the proportion of employees on ART increases. From 2010, the proportion of employees in each type of care remains relatively stable, with newly tested HIV-positive employees moving quickly through wellness care and, if eligible, onto ART, and the proportion of employees on second-line ART slowly increasing. From 2012, only 35%–44% of HIV-positive employees are on ART, because many are not eligible for ART; however, 75%–97% of employees with CD4 cell count < 350 cells/mm<sup>3</sup> are on ART.

**Fig. 2. Distribution of HIV-positive employees into types of HIV care, 2003–2022 (ART scenario)**

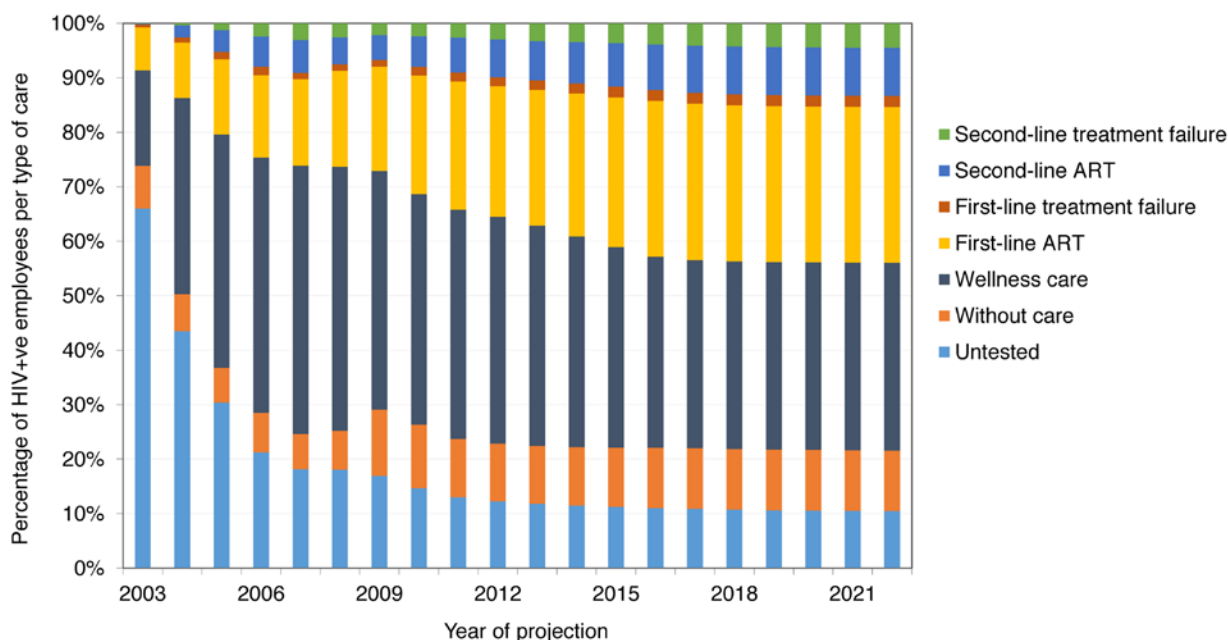

Across all available model fits, projections suggest that an HIV-infected employee with a current CD4 cell count > 350 cells/mm<sup>3</sup> will have a 39% (5th to 95th percentile range 35%–43%), 57% (50%–62%), or 78% (73%–82%) probability of surviving the following 10 y if they are in no care, in wellness care, or on ART, respectively. (Note that this survival does not take into account deaths in employees once they have left the workforce.) However, survival in the workforce at 10 y is much lower, as a result of death as well as disability and other separations: 16% (5th to 95th percentile range 13%–19%), 23% (20%–27%), and 35% (31%–39%) for employees in no care, in wellness care, and on ART, respectively.

Without ART, these survival rates lead to a total of 22,274 (5th to 95th percentile range 20,887–24,086) HIV-positive employee-years (or life-years in employment) at the mines between 2003 and 2022, with HIV prevalence increasing from 13.3% (5th to 95th percentile range 12.8%–14.4%) in 2010 to 14.3% (13.0%–

15.9%) in 2022. With ART coverage increasing from 10% of eligible HIV-positive employees in 2003 to 97% in 2020, the number of deaths amongst employees due to HIV over 20 y decreases by 16% (5th to 95th percentile range 11%–21%) from 1,583 (5th to 95th percentile range 1,406–1,791) without ART to 1,336 (1,183–1,497) with ART. Survival in employment increases by 8% (5th to 95th percentile range 6%–12%) to 24,134 (5th to 95th percentile range 22,848–25,841) HIV-positive life-years. This increase is not larger because on average only 34% of HIV-infected employees are on ART at any given time (since only a fraction of HIV-infected employees are eligible for ART), only a portion of these would have left the workforce or died in absence of ART over this period, and some leave the workforce before realising the full benefit of treatment. The increase in survival leads to an increase in HIV prevalence from 14.3% (5th to 95th percentile range 13.0%–15.9%) in 2022 without ART to 16.3% (14.9%–17.8%) with ART. HIV prevalence is always higher in the lower job grades: 21% (5th to 95th percentile range 19%–22%) in job grade 1 and 21% (18%–24%) in job grade 2 in 2022 with ART (Fig. 3).

**Fig. 3. Prevalence by job grade, 2003–2022, with workplace ART provision**

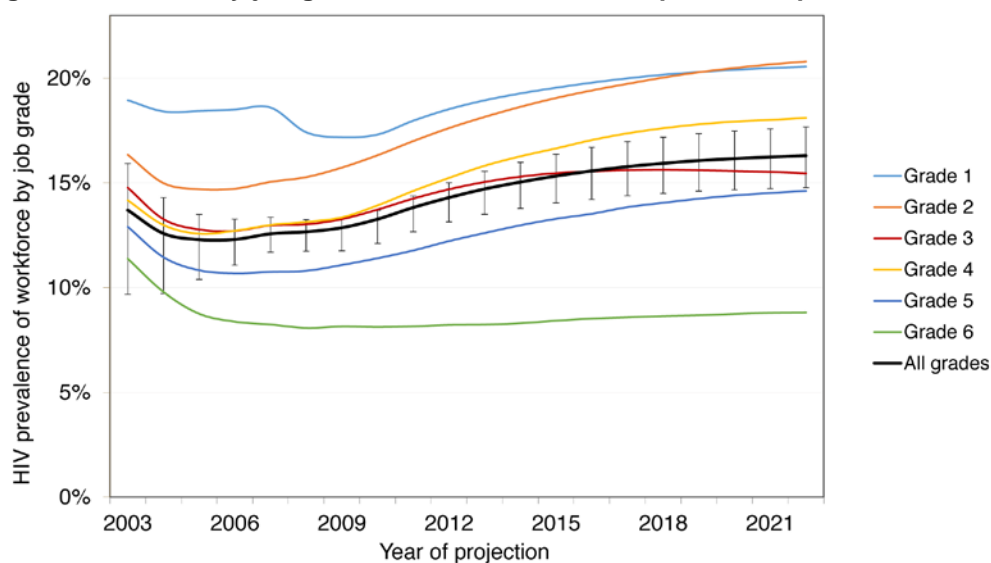

Job grade 1: unskilled worker; grades 2 and 3: semi-skilled worker; grades 4 and 5: skilled worker; grade 6: management.

### Changes in Workforce Turnover, Absenteeism, and Separations

With workplace ART provision, other changes are experienced by the workforce between 2003 and 2022. The total number of absent days due to HIV are estimated to be reduced by 8% (5th to 95th percentile range 6%–10%), from 330,172 (5th to 95th percentile range 297,729–367,723) to 303,897 (277,147–335,776) days, with 33% (5th to 95th percentile range 26%–40%) fewer absenteeism days amongst employees with CD4 cell counts below 100 (Fig. 4). The number of employees leaving employment for HIV-related reasons is estimated to decrease by 5% (5th to 95th percentile range 3%–7%) to 3,626 (5th to 95th percentile range 3,403–3,815) over 20 y, and the number of recruits is estimated to decrease by

2% (1%–3%) to 17,201 (16,454–17,912). Recruitment does not decrease further because of the large expansion of the company over this period (from 5,247 to 9,252 employees) and the considerable separations in the HIV-uninfected workforce.

**Fig. 4. Total number of days absent due to HIV per CD4-cell-count-defined health state, 2003–2022**

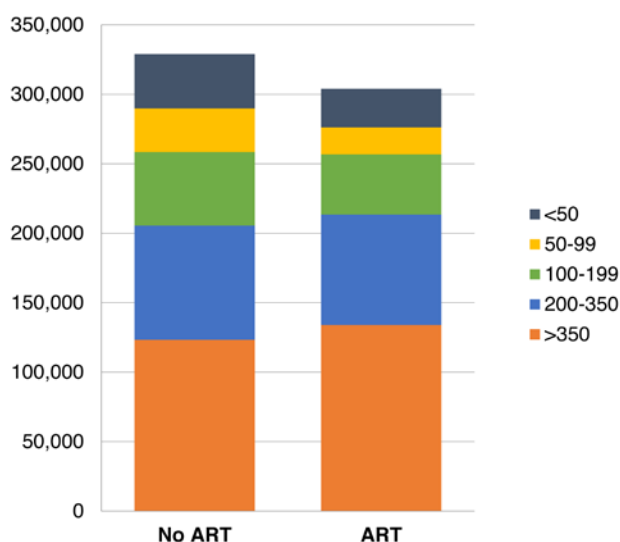

#### **Total and Average Cost with and without ART**

Without workplace ART provision, the undiscounted total cost of HIV to the company (including all healthcare, absenteeism, and turnover costs) over 20 y is estimated at US\$296 million (5th to 95th percentile range US\$274–US\$320 million) (Table 7), with the mean annual cost estimated to increase from US\$13 million (5th to 95th percentile range US\$12–US\$15 million) in the first 10 y to US\$15 million (US\$14–US\$16 million) over 20 y, mostly due to increasing HIV prevalence. This translates to a mean annual cost per HIV-positive employee of US\$13,271 (5th to 95th percentile range US\$12,101–US\$14,522) over 20 y. With ART, over 98% of model projections suggest that these costs decrease: the total and mean annual costs are estimated to decrease by 5% (5th to 95th percentile range 2%–8%) over 20 y, and the mean annual cost per HIV-positive employee by 9% (5%–13%). These savings are estimated to accrue from the first year of the ART programme onwards and to increase as the average CD4 cell count of HIV-positive employees on ART rises. Similar changes are seen with the discounted cost (Fig. S1). Moreover, ART is estimated to be cost-saving at even the lowest coverage level, as each employee on ART saves absenteeism, healthcare, and turnover costs that are greater than the per employee cost of ART.

**Table 7. Total cost of HIV to company with and without ART programme and cost savings due to ART (2010 USD) - main results and sensitivity analysis**

| Scenario   | No ART                 |                        | ART                    |                        | Savings from ART |              |
|--|------------------------|------------------------|------------------------|------------------------|------------------|--------------|
|  | By 2012                | By 2022                | By 2012                | By 2022                | By 2012          | By 2022      |
| <b>Cost of HIV to company: median (5th to 95th percentile range) from probabilistic sensitivity analysis</b> |                        |                        |                        |                        |                  |              |
| <b>Undiscounted</b>  |                        |                        |                        |                        |                  |              |
| Total cost (millions USD)  | 131 (118–147)          | 296 (274–320)          | 124 (112–140)          | 278 (256–299)          | 5% (2%–8%)       | 6% (1%–11%)  |
| Mean annual cost (millions USD)  | 13 (12–15)             | 15 (14–16)             | 12 (11–14)             | 14 (13–15)             | 5% (2%–8%)       | 6% (1%–11%)  |
| Mean annual cost per HIV-positive employee   | 14,208 (12,982–15,509) | 13,271 (12,101–14,522) | 12,893 (11,903–13,862) | 11,488 (10,601–12,218) | 9% (5%–13%)      | 14% (7%–19%) |
| <b>Discounted</b>  |                        |                        |                        |                        |                  |              |
| Total cost (millions USD)  | 155 (140–178)          | 269 (247–293)          | 148 (133–170)          | 253 (233–275)          | 5% (2%–7%)       | 6% (2%–10%)  |
| Mean annual cost (millions USD)  | 16 (14–18)             | 13 (12–15)             | 15 (13–17)             | 13 (12–14)             | 5% (2%–7%)       | 6% (2%–10%)  |
| Mean annual cost per HIV-positive employee   | 16,936 (15,383–18,624) | 12,045 (10,948–13,242) | 15,409 (14,137–16,780) | 10,492 (9,614–11,287)  | 9% (5%–13%)      | 13% (8%–18%) |
| <b>Sensitivity analysis: percent relative change in total undiscounted cost</b>                              |                        |                        |                        |                        |                  |              |
| Absenteeism reduced by 50%   | -9%                    | -11%                   | -0.4%                  | -1%                    | -5%              | -4%          |
| Same absenteeism on ART as not on ART <sup>1</sup>   | 3%                     | 3%                     | 3%                     | 4%                     | 5%               | 5%           |
| Same ART transition probabilities as public sector <sup>2</sup>  | 10%                    | 13%                    | 7%                     | 9%                     | 8%               | 10%          |
| Same ART cost as public sector <sup>3</sup>  | 3%                     | 3%                     | -1%                    | -4%                    | 8%               | 12%          |
| Change in inpatient cost: -50%   | -6%                    | -7%                    | -6%                    | -6%                    | 5%               | 5%           |
| Change in inpatient cost: +50%   | 11%                    | 12%                    | 10%                    | 10%                    | 6%               | 8%           |
| Change in outpatient cost: -50%  | 0.4%                   | -0.1%                  | -0.2%                  | -1%                    | 6%               | 7%           |
| Change in outpatient cost: +50%  | 5%                     | 6%                     | 5%                     | 5%                     | 5%               | 6%           |
| Change in benefits: two times annual salary paid   | -17%                   | -15%                   | -17%                   | -14%                   | 5%               | 5%           |
| Change in benefits: one times annual salary paid   | -36%                   | -34%                   | -35%                   | -31%                   | 4%               | 3%           |
| Change in benefits: no benefits paid out   | -56%                   | -52%                   | -54%                   | -48%                   | 1%               | -2%          |
| Change in HIV-dependent separation rates: -20%   | 0.1%                   | 3%                     | -1%                    | 2%                     | 6%               | 8%           |
| Change in HIV-dependent separation rates: +20%   | 5%                     | 2%                     | 5%                     | 2%                     | 5%               | 6%           |
| Change in HIV incidence: -50%  | -17%                   | -22%                   | -17%                   | -22%                   | 5%               | 6%           |
| Change in HIV incidence: +50%  | 21%                    | 26%                    | 20%                    | 25%                    | 6%               | 7%           |
| Change HIV incidence to 0.0001 and lower prevalence in starting population and recruits                      | -94%                   | -95%                   | -94%                   | -95%                   | 5%               | 4%           |
| <b>Additional scenarios: percent relative change in total undiscounted cost, 2013–2022</b>                   |                        |                        |                        |                        |                  |              |
| Test and treat <sup>4</sup>  | —                      | —                      | —                      | 0.2%                   | —                | 9%           |
| Family treatment <sup>5</sup>  | —                      | —                      | —                      | 9%                     | —                | 1%           |

<sup>1</sup>By CD4-cell-count-defined health state. <sup>2</sup>Based on [58] (public sector transition probabilities for first-line ART and first-line treatment failure only).

<sup>3</sup>US\$277, the average per patient annual cost of adult ART in the public sector for 2015/2016, with 7.5% of patients assumed on second-line ART (based on [59], updated using April 2015 government tender drug costs).

<sup>4</sup>100% coverage with HCT; 100% initiation on ART regardless of CD4 cell count and clinical status; 100% retention on ART; no impact on HIV incidence.

<sup>5</sup>For every employee known to be HIV-positive, treatment is offered to one additional HIV-positive dependant on average

### **Average Cost and Savings by Item**

Without ART provision, the largest components of the mean undiscounted annual cost of HIV to the company over 20 y are estimated to be benefit payments (53% of mean annual cost) and medical care costs (24%), followed by absenteeism (15%), and training and recruitment (8%) (Table 8). The cost of medical care is dominated by inpatient care (78% of medical care costs). Once ART is introduced, we estimate that benefit payments and medical care costs remain the largest contributors to the annual HIV costs (46% and 21%, respectively), whereas the cost of the ART programme itself is estimated to be comparatively small, at just 7% of the total.

**Table 8. Annual undiscounted cost and savings by cost item, 2003–2022**

| Cost Item                       | Annual Cost (Millions 2010 USD) |                  |                  |                  | Total (Compared to No ART) (Millions 2010 USD) | Savings from ART              |                                      |
|---------------------------------|---------------------------------|------------------|------------------|------------------|--|-------------------------------|--------------------------------------|
|                                 | No ART                          |                  | ART              |                  |  | Relative (Compared to No ART) | Percent of Total Saving <sup>1</sup> |
|                                 | Cost                            | Percent of Total | Cost             | Percent of Total |  |                               |                                      |
| <b>Medical care</b>             | 3.6 (3.3–3.9)                   | 24% (22%–27%)    | 3.0 (2.7–3.4)    | 21% (15%–26%)    | 0.57 (0.28 to 0.78)                            | 15% (–7% to 34%)              | 27% (8% to 37%)                      |
| Inpatient care                  | 2.8 (2.6–3.0)                   | 19% (17%–20%)    | 2.2 (2.0–2.4)    | 15% (11%–18%)    | 0.55 (0.41 to 0.68)                            | 19% (–1% to 38%)              | 27% (11% to 35%)                     |
| Outpatient care                 | 0.8 (0.6–1.1)                   | 6% (4%–7%)       | 0.8 (0.6–1.1)    | 6% (4%–8%)       | 0.03 (–0.26 to 0.19)                           | 2% (–41% to 32%)              | 0% (–14% to 11%)                     |
| <b>Absenteeism</b>              | 2.2 (2.0–2.4)                   | 15% (13%–16%)    | 1.9 (1.8–2.1)    | 13% (10%–16%)    | 0.25 (0.20 to 0.30)                            | 11% (–11% to 32%)             | 12% (4% to 22%)                      |
| <b>Benefits</b>                 | 7.8 (7.1–8.7)                   | 53% (50%–56%)    | 6.8 (6.1–7.5)    | 46% (33%–54%)    | 1.06 (0.69 to 1.52)                            | 13% (–2% to 39%)              | 52% (8% to 66%)                      |
| <b>Training and recruitment</b> | 1.2 (1.0–1.3)                   | 8% (7%–8%)       | 1.0 (0.9–1.1)    | 6% (5%–8%)       | 0.19 (0.13 to 0.25)                            | 15% (0.1% to 41%)             | 9% (0.1% to 12%)                     |
| <b>ART programme cost</b>       | —                               | —                | 1.1 (0.7–1.6)    | 7% (4%–11%)      | –1.10 (–1.61 to –0.71)                         | —                             | —                                    |
| <b>Total</b>                    | 14.8 (13.7–16.0)                |                  | 13.9 (12.8–15.0) |                  | 0.95 (0.22 to 1.62)                            | 14% (5% to 24%)               |                                      |

Values are median (5th to 95th percentile range) from the probabilistic sensitivity analysis.

<sup>1</sup>The values presented here are the mean (rather than median) (5th to 95th percentile range) from the probabilistic sensitivity analysis.

Overall, the average undiscounted annual savings from scaling up ART coverage over 20 y are estimated to be US\$950,215 (5th to 95th percentile range US\$220,879–US\$1,616,104). The largest contribution to these estimated savings (52% of total savings) is the 13% decrease in benefit payments, followed by the 15% decrease in medical care costs (27% of total savings) (Table 8). Although the cost of training and recruitment is estimated to fall by 15% with ART, this makes up only 9% of annual savings, whilst the cost of absenteeism, which falls by 11%, is estimated to contribute 12% of savings. Without ART, the total undiscounted annual cost of HIV to the company is estimated to make up 3.6% (5th to 95th percentile range 3.3%–3.9%) of total company payroll between 2003 and 2022, whereas with ART, this falls to 3.4% (3.1%–3.7%).

### **Sensitivity and Uncertainty Analysis and Additional Scenarios**

The univariate sensitivity analysis showed that total costs over 20 y are very sensitive to reductions in benefits paid for death and disability (–33%/66%) and changes in HIV incidence ( $\pm 50\%$ ), as well as to using public sector data for CD4 cell count transition probabilities, reductions in absenteeism (–50%), and changes in inpatient cost ( $\pm 50\%$ ) (Table 7). However, total costs do not change much if absenteeism by CD4 cell count category are assumed to be the same with and without ART or if the HIV-dependent separation rates ( $\pm 20\%$ ) or outpatient costs ( $\pm 50\%$ ) are changed. Equally, there is little change when ART costs from recent analyses of public sector ART provision are used [59]. Importantly, the only assumptions under which ART provision stops being cost-saving are if absenteeism is reduced by 50% (over both 10 and 20 y) or if no benefits are paid out (over 20 y only); under all other assumptions tested, ART still saves between 3% and 12% of total costs over 20 y. Finally, reducing HIV incidence as well as HIV prevalence in the starting population and recruits to low levels results in a much reduced HIV prevalence (1%) by 2022, representative of a low prevalence setting; in this scenario, the cost of HIV to the company reduces by 95% both without and with ART, with ART still saving 4% of costs.

The overall findings of the probabilistic sensitivity analysis agreed with the findings of the univariate sensitivity analysis, despite the wide ranges assigned to many model parameters, with over 98% of all model fits predicting that ART provision was cost-saving (Table 7). The analysis also reinforced the relative contribution of individual cost items to total cost (Table 8). The analysis of co-variance revealed that 69% of the variability in the total savings achieved with ART in the probabilistic sensitivity analysis (after 20 y and undiscounted) were explained by uncertainty in the costs of ART (64%), as well as in the difference between the upwards CD4-cell-count-defined health-state transition probabilities on ART compared to with wellness care (21%) (see Figs. S2 and S3), and in the outpatient costs on ART (15%). Interestingly, although the cost of ART is always a relatively small component of the total cost of HIV (5%–11%), it can contribute significantly to offsetting the cost savings achieved with ART, with the cost of ART cancelling out 53% (5th to 95th percentile range 32%–87%) of all potential savings. Importantly, the model projections suggest ART will always be cost-saving if it costs less than US\$2,057 per patient-year. The large dependence of the estimated cost savings on the difference between the ART and wellness care health-state transition probabilities



suggests that ART will not be cost-saving if it has little benefit for disease progression on top of what is already achieved with wellness care.

The cost of HIV in the test and treat sensitivity scenario over 10 y (2013–2022) increases only marginally, by 0.2%, because of increased savings in terms of inpatient care, absenteeism, and benefit payments, which almost offsets the cost of the additional treatment occurring (Table 7). In the family treatment scenario, total cost with ART provision between 2013 and 2022 increases by 9%, but ART provision is still marginally cost-saving.

## DISCUSSION

Using a dynamic health-state transition model, we conducted a cost–benefit analysis of an established ART programme operating in a number of coal mines in South Africa. Our analysis provides both a retrospective analysis of the programme between 2003 and 2010 and a projection of future developments based on the results of this retrospective analysis. When considering the impact of HIV on a company’s healthcare costs—as well as worker absenteeism, sickness and death benefits, and staff turnover—the introduction of ART to all eligible employees is cost-saving from the first year of the programme onwards. With ART provision, the total costs of HIV to the company over 20 y is estimated to be reduced by 6% (5th to 95th percentile range 2%–11%), and the cost per HIV-positive employee is estimated to be reduced by 14% (7%–19%). Moreover, in our probabilistic sensitivity analysis, 98% of the 998 model fits (selected from amongst 20,000 model runs) confirm this cost savings. The biggest savings are due to reductions in the benefit payments for death and ill-health retirement, followed by a decrease in the cost of employee healthcare use. This finding that ART is cost-saving is robust to the uncertainty around the model parameters as well as to other changes in numerous parameters or assumptions, including if absenteeism is the same for employees on and off ART, if there are large reductions in benefit payments, and if HIV prevalence in the workforce is decreased to below 1%. The only instance where ART does not save costs over 20 y is if absenteeism in HIV-positive employees is reduced by 50% or if no benefits are paid out—though the latter strategy still saves costs over 10 y. In addition, a strategy of offering HIV testing to all employees and immediate ART to all HIV-positive employees also results in savings to the cost of the HIV programme, suggesting test and treat be recommended as a powerful intervention for companies trying to preserve their employees’ productivity. Offering ART to one family member for each HIV-positive employee, a generous assumption, reduces savings but is still cost-saving compared to no workplace ART provision.

Previous work has shown a heterogeneous impact of HIV on absenteeism and replacement cost. In a study of nearly a thousand firms operating in Africa in 1997, the impact of HIV on staff turnover was minimal, probably because of the lower HIV prevalence at that time, with difficulties in replacing professional staff being the most significant problem companies were facing [60]. In another study, the total cost per HIV infection to South African companies was estimated at US\$2,094 to US\$15,000 for an unskilled worker (in 2001 prices) and US\$8,736 to US\$65,000 for a manager [2]. A study of a Natal

sugar mill found that on average 28 d were lost in each of the 2 y preceding retirement on grounds of ill-health and estimated that the cost of each HIV infection was roughly three times the employee's annual salary per year [61]. Similarly, a large part of the savings in our analysis were due to a policy of benefits being paid to the employee or their family in the case of disability or death, which might not apply to other workplaces and might limit the generalisability of the results across workplaces and countries.

While our analysis adds to the body of knowledge on the economic impact of HIV and ART—through the use of detailed modelling incorporating a wealth of data on costs of HIV and ART outcomes from the same setting—our study nonetheless has limitations. First, it was limited to the direct cost of HIV to companies. In a previous study, the life insurer Metropolitan predicted that the indirect costs of HIV to business (including costs due to a loss in morale, legal costs, management costs, and labour consultation costs) could add up to 15% of the wage and salary budget by 2010 [62]. The provision of ART could improve morale and retention of skilled employees [5] as well as help safeguard the company's license to mine [63]. Including this added indirect benefit of ART would have increased our savings from workplace ART provision. Second, we used an average drug cost for first-line and second-line ART that slightly underestimated the cost of ART in the later years of the projection, when more employees needed second-line ART, and did not stratify ART cost by time on treatment. However, since few HIV-positive employees were on second-line treatment throughout the projection period and the cost of ART was a small proportion of total costs, this underestimation is unlikely to change our findings. Third, data for some of the model inputs, such as transitions between certain CD4-cell-count-defined health states, was limited, resulting in uncertainty around some estimates. The effect of this uncertainty was included in our model projections as well as tested in our sensitivity analysis, and our results were found to be robust to changes along plausible ranges for these parameters. However, the deterministic nature of the model prevented it from capturing the full inherent variability present in this workforce. Lastly, we did not examine the impact of HIV prevention policies on the miners or their families.

Further work could involve evaluating the effects of prevention and treatment interventions on HIV incidence, including in the areas around the mines and in miners' families, and the cost of new policies such as providing pre-exposure prophylaxis or increasing the accommodation of miners' families in the vicinity of the mines, in compliance with the mining charter [63]. Finally, given our finding of the importance of the cost of ART in influencing cost savings, further reductions in the private sector cost of antiretroviral drugs remain crucial.

## **CONCLUSION**

Providing HIV care, including ART, in a workforce with high HIV prevalence and high resulting absenteeism and turnover can be cost-saving for the employer, with savings being greater at higher ART coverage, and might provide respite to the strained resources of large-scale public sector programmes. Beyond making good business sense, a company-level HIV care programme including ART could go a long way towards improving the strained labour relations in the South African mining

sector, especially when improved access to healthcare extends to the entire community [64]. It is crucial that strategies such as those under study here are replicated in other companies in similar settings.

### **Acknowledgments**

The authors are grateful to Salome Charalambous for her contribution to the clinical programme at the workplace, to Craig Innes for facilitating access to clinical datasets, to Thia Grobler, Sue Ingle, Margaret May, and Amy Huber for providing additional model inputs, and to the staff at the mines included in this study. This paper is dedicated to Wim Richter.

### **Financial Disclosure**

Funding for this study was obtained through a grant by GlaxoSmithKline to the Aurum Institute and direct funding from Anglo American. The funders had no role in study design, data collection and analysis, decision to publish, or preparation of the manuscript.

### **Conflicts of Interest**

GC is employed by the Aurum Institute, which received a small donation over the past few years from the Anglo American Chairman's fund. At the time of conception and design, acquisition of data, analysis and interpretation of data as well as at the time of the drafting of the article and revising it critically for important intellectual content, BB was employed by Anglo American as their Chief Medical Officer (previously designated Senior Vice President: Medical and/or Group Medical Consultant). He retired from Anglo American on 31st December 2014, but continued to have a part-time consultancy contract with the Company. The research work was carried out through the health services of Anglo American Coal mines in South Africa, for which BB was responsible for overarching professional oversight as Chief Medical Officer of Anglo American plc. The research work was partly funded by Anglo American Operations Limited, through a budget for which he was responsible. BB is an independent non-executive director of Right to Care (non-profit company), which has a close working relationship with Gesine Meyer-Rath's Health Economics and Epidemiology Research Office through shared directors.

**SUPPORTING INFORMATION**

**Fig. S1. Total annual cost with and without ART (discounted and undiscounted), 2003–2022 (2010 USD).**

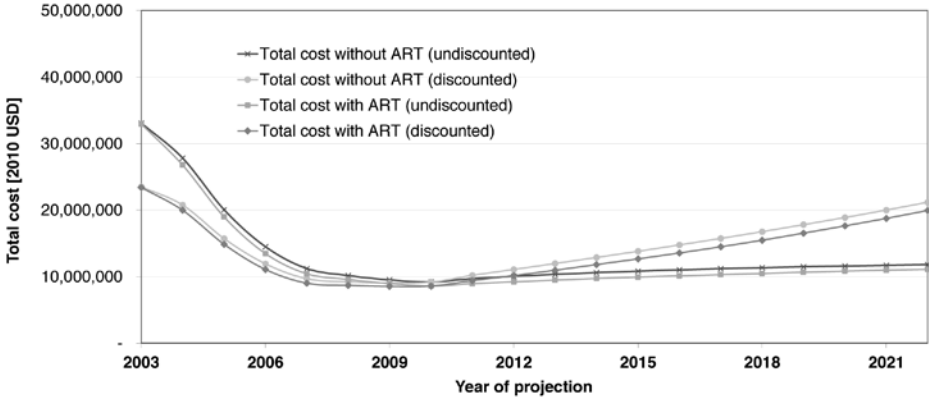

**Fig. S2. Results of analysis of co-variance: yearly cost of ART.**

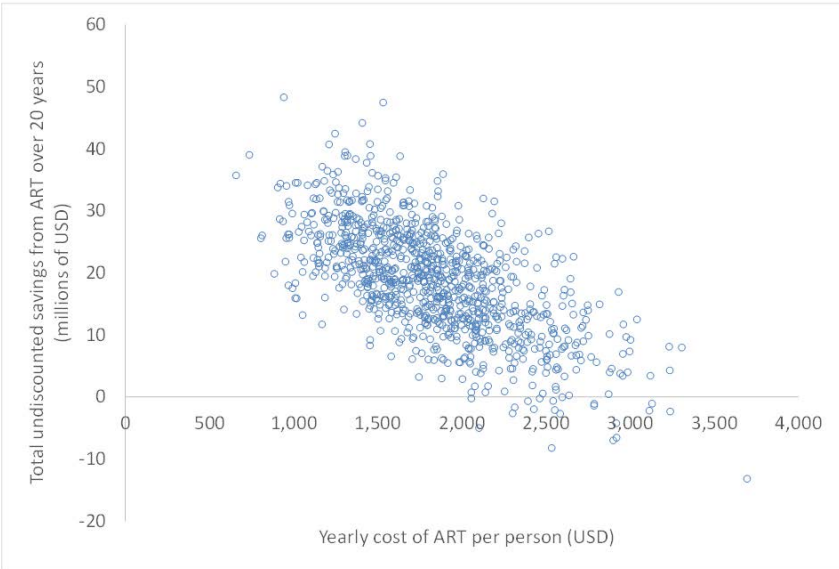

**Fig. S3. Results of analysis of co-variance: difference between wellness care and ART transition probabilities.**

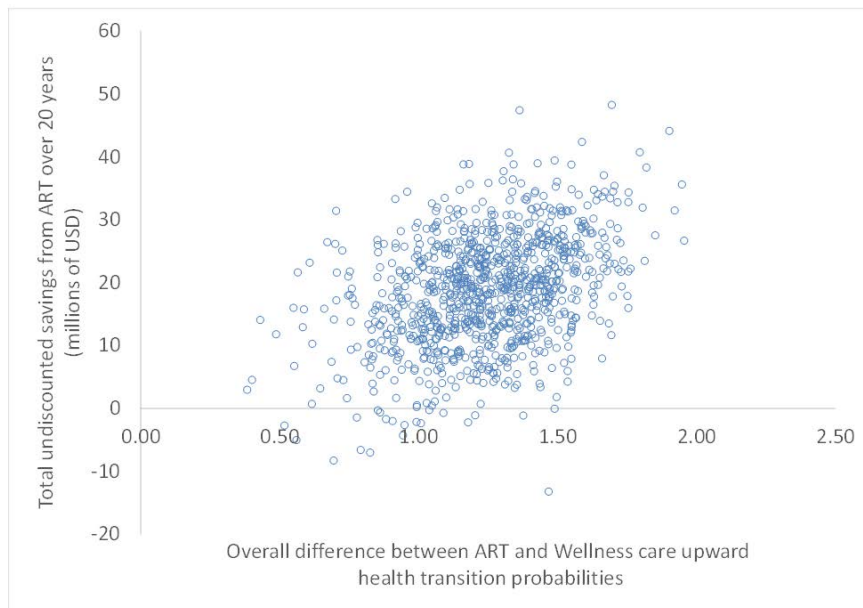

**Text S1. Details on parameter estimation, probabilistic sensitivity analysis, and model calculations (see Annex)**

## REFERENCES

1. Rosen S, Simon J, MacLeod W, Fox M, Thea DM. AIDS is your business. *Harv Bus Rev.* 2003;81:5-11.
2. Rosen S, Vincent JR, MacLeod W, Fox M, Thea DM, Simon JL. The cost of HIV/AIDS to businesses in southern Africa. *AIDS.* 2004;18:317-324.
3. Rosen S, Feeley F, Connelly P, Simon J. The private sector and HIV/AIDS in Africa: taking stock of 6 years of applied research. *AIDS.* 2007;21 Suppl 3:S41-S51.
4. Rajak D. 'HIV/AIDS is our business': the moral economy of treatment in a transnational mining company. *J R Anthropol Inst.* 2010;16:551-571.
5. Brink B, Pienaar J. Business and HIV/AIDS: the case of Anglo American. *AIDS.* 2007;21 Suppl 3:S79-S84.
6. Greener R. Impact of HIV/AIDS and options for intervention: results of a five company pilot study. Working Paper No. 10. Gaborone: Botswana Institute of Development Policy Analysis; 1997.
7. Feeley F, Bukuluki P, Collier A, Fox M. The impact of HIV/AIDS on productivity and labor costs in two Ugandan corporations. Boston: Center for International Health and Development, Boston University; 2004.
8. AIDS Control and Prevention Project. Private sector AIDS policy: African workplace profiles. Washington (District of Columbia): Family Health International; 1995.
9. Fox MP, Rosen S, MacLeod WB, Wasunna M, Bii M, Foglia G, et al. The impact of HIV/AIDS on labour productivity in Kenya. *Trop Med Int Health.* 2004;9:318-324.

10. Joint United Nations Programme on HIV/AIDS. Global report: UNAIDS report on the global AIDS epidemic 2013. Geneva: Joint United Nations Programme on HIV/AIDS; 2013.
11. Shisana O, Rehle T, Simbayi LC, Zuma K, Jooste S, Pillay-van-Wyk V, et al. South African national HIV prevalence, incidence, behaviour and communication survey, 2008: a turning tide among teenagers? Cape Town: HSRC Press; 2009.
12. Shisana O, Rehle T, Simbayi LC, Zuma K, Jooste S, Zungu N, et al. South African national HIV prevalence, incidence and behaviour survey, 2012. Cape Town: HSRC Press; 2014.
13. Evian C, Fox M, MacLeod B, Slotow S, Rosen S. Prevalence of HIV in workforces in southern Africa, 2000-2001. *S Afr Med J.* 2004;94:125-130.
14. Harling G, Wood R. The evolving cost of HIV in South Africa: changes in health care cost with duration on antiretroviral therapy for public sector patients. *J Acquir Immune Defic Syndr.* 2007;45:348-354.
15. Rosen S, Kethlapile M, Sanne I, Bachman DeSilva M. Cost to patients of obtaining treatment for HIV/AIDS in South Africa. *S Afr Med J.* 2007;97:524-529.
16. Rosen S, Long L, Sanne I. The outcomes and outpatient costs of different models of antiretroviral treatment delivery in South Africa. *Trop Med Int Health.* 2008;13:1005-1015.
17. Rosen S, Long L, Fox M, Sanne I. Cost and cost-effectiveness of switching from stavudine to tenofovir in first-line antiretroviral regimens in South Africa. *J Acquir Immune Defic Syndr.* 2008;48:334-344.
18. Stearns BK, Evans DK, Lutung P, Wagner G, Ryan G, Aledort JE. Primary estimates of the costs of ART care at 5 AHF clinics in sub-Saharan Africa. Abstract MOPE0706. XVIIIth International AIDS Conference; 3–8 Aug 2008; Mexico City, Mexico.
19. Leisegang R, Cleary S, Hislop M, Davidse A, Regensberg L, Little F, et al. Early and late direct costs in a Southern African antiretroviral treatment programme: a retrospective cohort analysis. *PLoS Med.* 2009;6:e1000189. doi:10.1371/journal.pmed.1000189
20. Martinson N, Mohapi L, Bakos D, Gray LE, McIntyre JA, Holmes CB. Costs of providing care for HIV-infected adults in an urban HIV clinic in Soweto, South Africa. *J Acquir Immune Defic Syndr.* 2009;50:327-330.
21. Kevany S, Meintjes G, Rebe K, Maartens G, Cleary S. Clinical and financial burdens of secondary level care in a public sector antiretroviral roll-out setting (G F Jooste Hospital). *S Afr Med J.* 2009;99:320-325.
22. Long L, Fox M, Sanne I, Rosen S. The high cost of second-line antiretroviral therapy for HIV/AIDS in South Africa. *AIDS.* 2010;24:915-919.
23. Long L, Brennan A, Fox MP, Ndibongo B, Jaffray I, Sanne I, et al. Treatment outcomes and cost-effectiveness of shifting management of stable ART to nurses in South Africa: an observational cohort. *PLoS Med.* 2011;8:e1001055. doi:10.1371/journal.pmed.1001055
24. Cleary S, Blecher M, Boulle A, Dorrington R, Darkoh E, Bogopane-Zulu H. The costs of the National Strategic Plan on HIV and AIDS & STIs 2007–2011. Cape Town: University of Cape Town, National Treasury, Broadreach Health Care, and South African Parliament; 2007.
25. Meyer-Rath G, Brennan A, Long L, Ndibongo B, Technau K, Moultrie H, et al. Cost and outcomes of paediatric antiretroviral treatment in South Africa. *AIDS.* 2012;27:243-250.
26. Meyer-Rath G, Miners A, Santos A, Variava E, Venter F. Cost and resource use of patients on antiretroviral therapy in the urban and semi-urban public sectors of South Africa. *J Acquir Immune Defic Syndr.* 2012;61:e25-e32.
27. Meyer-Rath G, Brennan A, Fox MP, Modisenyane T, Tshabangu N, Mohapi L, et al. Rates and cost of hospitalisation before and after initiation of antiretroviral therapy in the urban and rural public sector of South Africa. *J Acquir Immune Defic Syndr.* 2013;62:322-328.
28. Leisegang R, Maartens G, Hislop M, Sargent J, Darkoh E, Cleary S. A novel Markov model projecting costs and outcomes of providing antiretroviral therapy to public patients in private practices versus public clinics in South Africa. *PLoS ONE.* 2013;8:e53570. doi:10.1371/journal.pone.0053570

29. Cleary S, McIntyre D, Boule A. The cost-effectiveness of antiretroviral treatment in Khayelitsha, South Africa—a primary data analysis. *Cost Eff Resour Alloc.* 2006;4:20.
30. Badri M, Maartens G, Mandalia S, Bekker L-G, Penrod JR, Platt RW, et al. Cost-effectiveness of highly active antiretroviral therapy in South Africa. *PLoS Med.* 2006;3:e4.
31. Bachmann MO. Effectiveness and cost effectiveness of early and late prevention of HIV/AIDS progression with antiretrovirals or antibiotics in Southern African adults. *AIDS Care.* 2006;18:109-120.
32. Holmes CB, Zheng H, Martinson NA, Freedberg KA, Walensky RP. Optimizing treatment for HIV-infected South African women exposed to single-dose nevirapine: balancing efficacy and cost. *Clin Infect Dis.* 2006;42:1772-1780.
33. Granich RM, Gilks CF, Dye C, De Cock KM, Williams BG. Universal voluntary HIV testing with immediate antiretroviral therapy as a strategy for elimination of HIV transmission: a mathematical model. *Lancet.* 2009;373:48-57.
34. Cleary S, Mooney G, McIntyre D. Equity and efficiency in HIV-treatment in South Africa: the contribution of mathematical programming to priority setting. *Health Econ.* 2009;19:1166-1180.
35. Cleary S, McIntyre D. Financing equitable access to antiretroviral treatment in South Africa. *BMC Health Serv Res.* 2010;10 Suppl 1:S2.
36. Walensky RP, Wolf LL, Wood R, Fofana MO, Freedberg KA, Martinson NA, et al. When to start antiretroviral therapy in resource-limited settings. *Ann Int Med.* 2009;151:157-166.
37. Walensky RP, Wood R, Ciaranello AL, Paltiel AD, Lorenzana SB, Anglaret X, et al. Scaling up the 2010 World Health Organization HIV treatment guidelines in resource-limited settings: a model-based analysis. *PLoS Med.* 2010;7:e1000382. doi:10.1371/journal.pmed.1000382
38. Wagner B, Blower S. Costs of eliminating HIV in South Africa have been underestimated. *Lancet.* 2010;376:953.
39. Hontelez JAC, de Vlas SJ, Tanser F, Bakker R, Bärnighausen T, Newell ML, et al. The impact of the new WHO antiretroviral treatment guidelines on HIV epidemic dynamics and cost in South Africa. *PLoS ONE.* 2011;6:e21919. doi:10.1371/journal.pone.0021919
40. Bendavid E, Grant P, Talbot A, Owens DK, Zolopa A. Cost-effectiveness of antiretroviral regimens in the World Health Organization's treatment guidelines: a South African analysis. *AIDS.* 2011;25:211-220.
41. Ciaranello AL, Lockman S, Freedberg KA, Hughes M, Chu J, Currier J, et al. First-line antiretroviral therapy after single-dose nevirapine exposure in South Africa: a cost-effectiveness analysis of the OCTANE trial. *AIDS.* 2011;25:479-492.
42. Hallett TB, Baeten JM, Heffron R, Barnabas R, de Bruyn G, Cremin Í, et al. Optimal uses of antiretrovirals for prevention in HIV-1 serodiscordant heterosexual couples in South Africa: a modelling study. *PLoS Med.* 2011;8:e1001123. doi:10.1371/journal.pmed.1001123
43. Eaton JW, Menzies NA, Stover J, Cambiano V, Chindelevitch L, Cori A, et al. Health benefits, costs, and cost-effectiveness of earlier eligibility for adult antiretroviral therapy and expanded treatment coverage: a combined analysis of 12 mathematical models. *Lancet Glob Health.* 2013;2:23-34. doi:10.1016/S2214-109X(13)70172-4
44. Granich R, Kahn JG, Bennett R, Holmes CB, Garg N, Serenata C, et al. Expanding ART for treatment and prevention of HIV in South Africa: estimated cost and cost-effectiveness 2011–2050. *PLoS ONE.* 2012;7:e30216. doi:10.1371/journal.pone.0030216
45. Alistar SS, Grant PM, Bendavid E. Comparative effectiveness and cost-effectiveness of antiretroviral therapy and pre-exposure prophylaxis for HIV prevention in South Africa. *BMC Med.* 2014;12:46.
46. Larson BA, Fox MP, Rosen S, Bii M, Sigei C, Shaffer D, et al. Early effects of antiretroviral therapy on work performance: preliminary results from a cohort study of Kenyan agricultural workers. *AIDS.* 2008;22:421-425.

47. Larson BA, Fox MP, Rosen S, Bii M, Sigei C, Shaffer D, et al. Do the socioeconomic impacts of antiretroviral therapy vary by gender? A longitudinal study of Kenyan agricultural worker employment outcomes. *BMC Public Health*. 2009;9:240.
48. Thirumurthy H, Zivin JG, Goldstein M. The economic impact of AIDS treatment: labor supply in western Kenya. *J Hum Resour*. 2008;43:511-552.
49. Fox MP, McCoy K, Larson BA, Rosen S, Bii M, Sigei C, et al. Improvements in physical wellbeing over the first two years on antiretroviral therapy in western Kenya. *AIDS Care*. 2010;22:137-145.
50. Habariyamana J, Mbakile B, Pop-Eleches C. The impact of HIV/AIDS and ARV treatment on worker absenteeism- implications for African firms. *J Hum Resour*. 2010;45:809-839.
51. Marseille E, Saba J, Musingo S, Kahn JG. The costs and benefits of private sector provision of treatment to HIV-infected employees in Kampala, Uganda. *AIDS*. 2006;20:907-914.
52. Ingle SM. Modelling waiting times for HIV antiretroviral therapy in South Africa: patient management, outcomes and treatment rationing strategies in the Free State Province. PhD dissertation. University of Bristol. 2010.
53. Huber A, Pienaar J, Innes C, Felix M, Churchyard GJ, Hoffmann CJ, et al. Impact of universal VCT on population HIV incidence within a cohort of South African coal miners. *International AIDS Society Conference*; 17–20 July 2011; Rome, Italy.
54. Muirhead D, Kumaranayake L, Pozo-Martin F, Charalambous S, Pemba L, Grant A. Early savings resulting from employer-sponsored ART in a large South African workforce setting. Abstract 652. 2nd South African AIDS Conference; 7–10 June 2005; Durban, South Africa.
55. Charalambous S, Innes C, Muirhead D, Kumaranayake L, Fielding K, Pemba L, et al. Evaluation of a workplace HIV treatment programme in South Africa. *AIDS*. 2007;21 Suppl 3:S73-S78.
56. South African Reserve Bank. Repo rate. Available: <http://www.resbank.co.za/Research/Rates/Pages/Repo%20Rate.aspx>. Accessed 29 July 2015.
57. Briggs AH, Sculpher MJ, Claxton K. *Decision modelling for health economic evaluation*. 1st ed. Oxford: Oxford University Press; 2006.
58. Meyer-Rath G, Brennan A, Long L, Rosen S, Fox MP. Survival in care and CD4 cell count gain on first-line ART depend on prior CD4 cell count and time on treatment: evidence from a large South African cohort. Abstract Z-148. 17th Conference on Retroviruses and Opportunistic Infections; 16–19 February 2010; San Francisco, US.
59. Meyer-Rath G, Pillay Y, Blecher M, Brennan A, Long L, Johnson LF, et al: Total cost and potential cost savings of the national antiretroviral treatment (ART) programme in South Africa 2010 to 2017. Abstract WEAE0201. XVIII International AIDS Conference; 18–23 July 2010; Vienna, Austria.
60. Biggs T, Shah M. The impact of the AIDS epidemic on African firms. RPED Discussion Paper #72. Washington (District of Columbia): World Bank, Africa Region; 1997.
61. Morris C, Burdge D, Cheevers E. Economic impact of HIV infection in a cohort of sugar mill workers in South Africa. *S Afr J Econ*. 2000;68:413-419.
62. Moore D. The AIDS threat and the private sector. *AIDS Anal Afr*. 1999;9:1-2.
63. Republic of South Africa Department of Mineral Resources. Amendment of the broad-based socio-economic empowerment charter for the South African mining and minerals industry. Pretoria: Republic of South Africa Department of Mineral Resources; 2010.
64. Brink B. The business case for extractive industry involvement in the fight against AIDS and TB. Abstract MOSS0302. International AIDS Conference; 20–25 July 2014; Melbourne, Australia.



## ANNEX

### 1. Additional details on parameter estimation and data sources

#### Choice of parameters, distributions and shape parameters for probabilistic sensitivity analysis

Beta distributions were assigned to binomial events such as the proportion of individuals that experience either a HIV-related or non HIV-related separation, treatment failure or loss to ART retention in a specific time period, as well as the proportion of recruits that are newly HIV-infected in a specific year. Normal distributions were assigned to the number of absenteeism days experienced by individuals on or off ART for different CD4 cell count categories. Dirichlet distributions were assigned to the upward and downward transition probabilities between CD4 cell-count defined health states (further details below table). Lastly, because of the over dispersed nature of cost data, gamma distributions were assigned to the costs of in- and outpatient care for individuals on or off ART and to the cost of ART (which includes the cost of drugs, labs, other medical supplies, staff time, site programme cost and central management cost). Specific details on the parameter distributions used for each parameter and the justification for those assumptions are given in Table S2. Notation for the Gamma, normal and beta distribution is standard: Beta( $\alpha, \beta$ ) gives a continuous approximation to a binomial distribution with  $\alpha$  successes and  $\beta$  failures;  $N(\mu, s^2)$  denotes a normal distribution with mean  $\mu$  and standard deviation  $s$ ; and  $G(a, b)$  denotes a gamma distribution with scale  $a$  and shape  $b$ .

**Table S2: Summary of parameter values and the distributions chosen for their ranges**

| Parameter                                 | Mean and 95% CI    | Distribution  | Reason for choice of distribution  |
|---|--------------------|---|--|
| <b>HIV incidence</b>                      |                    |   |  |
| 2005                                      | 1.9% (1.5-2.3%)    | Triangular with likeliest of 1.7% and min of 1.2% and maximum of 2.6% | HIV incidence varied across the years 2005 to 2009 with no obvious pattern, and so chose triangular distribution with most likely value being average across the years and the limits being the maximum and minimum of the 95% confidence intervals across the years.            |
| 2006                                      | 2.2% (1.8-2.6%)    |   |  |
| 2007                                      | 1.6% (1.3-1.9%)    |   |  |
| 2008                                      | 1.4% (1.2-1.7%)    |   |  |
| 2009                                      | 1.6% (1.4-2.0%)    |   |  |
| <b>HIV-dependent separations per year</b> |                    |   |  |
| <b>- Disability/III-health</b>            |                    |   |  |
| CD4>350                                   |                    |   | The distribution for all separation rates was estimated directly from the data used to derive it based on the number that separated out of each CD4 health state ( $\alpha$ in Beta( $\alpha, \beta$ )) from the total sample ( $\alpha + \beta$ ) for specific CD4 health state |
| CD4 200-350                               | 0.76% (0.39-1.33%) | Beta(12,1563)   |  |
| CD4 100-200                               | 1.51% (0.90-2.37%) | Beta(4,5122))   |  |
| CD4 50-100                                | 2.09% (1.15-3.48%) | Beta(14,655)  |  |
| CD4<50                                    | 2.69% (0.99-5.76%) | Beta(6,217)   |  |
| <b>- Death</b>                            |                    |   |  |
| CD4>350                                   |                    | Beta(24,150)  |  |
| CD4 200-350                               | 1.90% (1.29-2.71%) | Beta(30,1546)   |  |
| CD4 100-200                               | 3.94% (2.91-5.20%) | Beta(47,1146)   |  |
| CD4 50-100                                | 9.25% (7.17-11.7%) | Beta(62,608)  |  |
| CD4<50                                    | 24.7% (19.2-30.9%) | Beta(55,167)  |  |
| <b>- Other</b>                            |                    |   |  |
| CD4>350                                   |                    | Beta(117,57)  |  |
| CD4 200-350                               | 6.98% (5.77-8.36%) | Beta(110,1466)  |  |
| CD4 100-200                               | 8.13% (6.64-9.83%) | Beta(97,1095)   |  |
| CD4 50-100                                | 8.51% (6.51-10.9%) | Beta(57,612)  |  |

|   |                    |                 |   |
|---|--------------------|-----------------|---|
| CD4<50  | 8.97% (5.56-13.5%) | Beta(20,203)    |   |
|   | 12.6% (8.10-18,5%) | Beta(22,152)    |   |
| <b>Non HIV-dependent separations per year</b>         |                    |                 |   |
| <b>- Disability/III-health</b>                        |                    |                 |   |
| Job grade 1   | 0.66% (0.31-1.21%) | Beta(10,1501)   | The distribution for all separation rates was estimated directly from the data used to derive it based on the number that separated out of each job grade strata ( $\alpha$ in Beta( $\alpha,\beta$ )) from the total sample ( $\alpha+\beta$ ) for specific job grade categories.  |
| Job grade 2   | 0.08% (0.02-0.20%) | Beta(4,5122)    |   |
| Job grade 3   | 0.21% (0.14-0.31%) | Beta(26,12,126) |   |
| Job grade 4   | 0.24% (0.16-0.36%) | Beta(25,10,250) |   |
| Job grade 5   | 0.09% (0.03-0.22%) | Beta(5,5405)    |   |
| Job grade 6   | 0.03% (0.00-0.14%) | Beta(1,3864)    |   |
| <b>- Death</b>  |                    |                 |   |
| Job grade 1   | 0.99% (0.56-1.63%) | Beta(15,1496)   |   |
| Job grade 2   | 0.21% (0.11-0.38%) | Beta(11,5115)   |   |
| Job grade 3   | 0.57% (0.44-0.72%) | Beta(69,12083)  |   |
| Job grade 4   | 0.35% (0.25-0.48%) | Beta(36,10239)  |   |
| Job grade 5   | 0.28% (0.16-0.46%) | Beta(15,5395)   |   |
| Job grade 6   | 0.26% (0.12-0.48%) | Beta(10,3855)   |   |
| <b>- Other</b>  |                    |                 |   |
| Job grade 1   | 5.63% (4.52-6.91%) | Beta(85,1426)   |   |
| Job grade 2   | 1.50% (1.19-1.87%) | Beta(77,5049)   |   |
| Job grade 3   | 1.78% (1.55-2.03%) | Beta(216,11936) |   |
| Job grade 4   | 8.53% (7.99-9.08%) | Beta(876,9399)  |   |
| Job grade 5   | 4.79% (4.23-5.39%) | Beta(259,5151)  |   |
| Job grade 6   | 5.92% (5.20-6.72%) | Beta(229,3636)  |   |
| <b>- Retrenchment</b>                                 |                    |                 |   |
| Job grade 1   | 0.26% (0.07-0.68%) | Beta(4,1507)    |   |
| Job grade 2   | 0.33% (0.19-0.53%) | Beta(17,5109)   |   |
| Job grade 3   | 0.09% (0.04-0.16%) | Beta(11,12141)  |   |
| Job grade 4   | 1.18% (0.98-1.41%) | Beta(121,10154) |   |
| Job grade 5   | 0.57% (0.39-0.81%) | Beta(31,5379)   |   |
| Job grade 6   | 0.57% (0.36-0.86%) | Beta(22,3843)   |   |
| <b>Prevalence in recruits</b>                         |                    |                 |   |
|   | 3.50% (2.41-4.91%) | Beta(32,914)    | The distribution for yearly recruit prevalence estimates was estimated directly from data on the number of HIV positive recruits (32) out of the total number of new recruits tested (32+914) over years 2003 to 2010. The same prevalence was used for all years.  |
| <b>Outpatient cost without ART (2010 ZAR)</b>         |                    |                 |   |
| CD4>350   | 1,353 (sd=1,656)   | G(54,24)        | As is standard practice, gamma distributions were assumed for all cost parameters because of their usual over dispersion. The shape (a) and scale (b) parameters for each distribution G(a,b) were derived using the method of moments where $a=(\text{mean}/\text{SE})^2$ and $b=\text{SE}^2/\text{mean}$ , with mean being the mean cost from the sample and SE being the standard error around the mean of the cost estimates in the sample. This was done for the cost data collected for in-patient as well as out-patient costs with each being stratified by the CD4 cell count of the individual. This was also done for the cost of ART for each individual. This was not stratified by CD4 count because the cost of ART did not vary by this variable within our data. |
| CD4 200-350   | 1,211 (sd=1675)    | G(141,9)        |   |
| CD4 100-200   | 1,253 (sd=2391)    | G(67,19)        |   |
| CD4 50-100  | 1,033 (sd=1331)    | G(54,19)        |   |
| CD4<50  | 1,998 (sd=5647)    | G(11,181)       |   |
| <b>Inpatient cost without ART per year (2010 ZAR)</b> |                    |                 |   |
| CD4>350   | 2,680 (sd=1,1827)  | G(4.4,607)      |   |
| CD4 200-350   | 3,403 (sd=1,4206)  | G(15,220)       |   |
| CD4 100-200   | 4,456 (sd=1,4432)  | G(23,193)       |   |
| CD4 50-100  | 1,4658 (sd=32,709) | G(18,820)       |   |
| CD4<50  | 9,227 (sd=18,575)  | G(22,425)       |   |
| <b>Outpatient cost with ART per year (2010 ZAR)</b>   |                    |                 |   |
| CD4>350   | 977 (sd=1,048)     | G(704,1.4)      |   |
| CD4 200-350   | 993 (sd=1,255)     | G(1015,1.0)     |   |
| CD4 100-200   | 963 (sd=1,280)     | G(62,16)        |   |
| CD4 50-100  | 990 (sd=1,030)     | G(373,2.7)      |   |
| CD4<50  | 1,176 (sd=1,905)   | G(84,14)        |   |
| <b>Inpatient cost with ART per year (2010 ZAR)</b>    |                    |                 |   |
| CD4>350   | 1,779 (sd=6,415)   | G(62,29)        |   |
| CD4 200-350   | 1,064 (sd=9,910)   | G(19,57)        |   |
| CD4 100-200   | 1,755 (sd=1,1035)  | G(2.8,637)      |   |
| CD4 50-100  | 2,426 (sd=1,1388)  | G(18,132)       |   |
| CD4<50  | 9,327 (sd=27,070)  | G(26,357)       |   |

| <b>Cost of ART per year (2010 ZAR)</b>                 |                     |               |   |
|--|---------------------|---------------|---|
|  | 14,611              | G(1034,14)    |   |
| <b>Absenteeism days per quarter without ART</b>        |                     |               |   |
| CD4>350  | 4.59 (2.70-6.48)    | N(4.6,0.56)   | The distribution for number of absenteeism days was estimated directly from the data used to derive it based on the distribution of the number of absenteeism days reported by individuals with different CD4 cell counts. However, we did not sample from the full distribution across all individuals, but from the likely distribution around the mean for each CD4 cell count category. For this reason the standard error was used as the second parameter of the normal distribution and the mean was assumed to be normally distributed. |
| CD4 200-350  | 3.78 (2.93-4.63)    | N(3.8,0.25)   |   |
| CD4 100-200  | 6.06 (4.82-7.30)    | N(6.1,0.37)   |   |
| CD4 50-100   | 9.63 (7.06-12.20)   | N(9.6,0.76)   |   |
| CD4<50   | 13.80 (10.54-17.06) | N(13.8,0.96)  |   |
| <b>Absenteeism days per quarter with ART</b>           |                     |               |   |
| CD4>350  | 2.64 (2.20-3.08)    | N(2.6,0.13)   |   |
| CD4 200-350  | 3.18 (2.83-3.53)    | N(3.2,0.10)   |   |
| CD4 100-200  | 4.02 (3.48-4.56)    | N(4.0,0.16)   |   |
| CD4 50-100   | 5.64 (4.45-6.83)    | N(5.6,0.35)   |   |
| CD4<50   | 13.83 (10.79-16.87) | N(13.8,0.90)  |   |
| <b>Treatment failure</b>                               |                     |               |   |
| 2003 to 2006   | 11.2% (8.47-14.3%)  | Beta(53,422)  | The distribution for treatment failure rate was estimated directly from the data used to derive it based on the proportion of individuals on treatment that failed treatment in each year. Rates were averaged for 2003 to 2006 and 2007 to 2010 to account for any variation over time. Rates after 2010 were assumed to be the same as for 2010.  |
| 2007 to 2010   | 8.09% (6.48-9.96%)  | Beta(81,918)  |   |
| <b>Loss to retention from Wellness</b>                 |                     |               |   |
| 2003 to 2006   | 0.67% (0.27-1.37%)  | Beta(7,1045)  | The distribution for each loss to retention rate was estimated directly from the data used to derive it based on the proportion of individuals on wellness care that were lost to follow up in each year. Rates were averaged for 2003 to 2006 and 2007 to 2010 to account for any variation over time. Rates after 2010 were assumed to be the same as for 2010.   |
| 2007 to 2010   | 1.74% (1.18-2.46%)  | Beta(31,1754) |   |
| <b>Loss to retention from ART or treatment failure</b> |                     |               |   |
| 2003 to 2006   | 8.42% (6.08-11.29%) | Beta(40,435)  | The distribution for each loss to retention was estimated directly from the data used to derive it based on the proportion of individuals on ART that were lost to follow up in each year. Rates were averaged for 2003 to 2006 and 2007 to 2010 to account for any variation over time. Rates after 2010 were assumed to be the same as for 2010.  |
| 2007 to 2010   | 9.89% (8.11-11.91%) | Beta(99,1001) |   |

For the CD4 transition probabilities, Dirichlet distributions were assumed for the alternative transitions from each baseline CD4 cell count strata over the next quarter- this is standard practice for variables that have multiple transition options. The data used to estimate the transition probabilities between

health states is shown below from which the Dirichlet distributions were derived for the alternatives in each column. In this table, N denotes the number of 3-month periods of follow up and the numbers above each are the transitions that occurred over those time periods. Note that 1 = health state 1 (CD4 > 350 cells/microl), 2 = health state 2 (CD4 200-350 cells/microl), 3 = health state 3 (CD4 = 100-199 cells/microl), 4 = health state 4 (CD4 50-99 cells/microl), 5 = health state 5 (CD4 <50 cells/microl).

| <b>No care</b>   | from 1       | 2            | 3            | 4          | 5          |
|------------------|--------------|--------------|--------------|------------|------------|
| to 1             | 3,852        | -            | -            | -          | -          |
| 2                | 193          | 2,516        | -            | -          | -          |
| 3                | 33           | 159          | 1,914        | -          | -          |
| 4                | 5            | 24           | 81           | 706        | -          |
| 5                | 10           | 26           | 43           | 74         | 915        |
| <b>Total (N)</b> | <b>4,093</b> | <b>2,725</b> | <b>2,038</b> | <b>780</b> | <b>915</b> |
|                  |              |              |              |            |            |
| <b>Wellness</b>  | from 1       | 2            | 3            | 4          | 5          |
| to 1             | 903          | 80           | 1            | 0          | 0          |
| 2                | 135          | 355          | 32           | 2          | 2          |
| 3                | 11           | 62           | 82           | 8          | 2          |
| 4                | 1            | 1            | 19           | 22         | 4          |
| 5                | 1            | 0            | 5            | 8          | 20         |
| <b>Total (N)</b> | <b>1,051</b> | <b>498</b>   | <b>139</b>   | <b>40</b>  | <b>28</b>  |
|                  |              |              |              |            |            |
| <b>ART</b>       | from 1       | 2            | 3            | 4          | 5          |
| to 1             | 1490         | 169          | 5            | 0          | 1          |
| 2                | 104          | 593          | 81           | 1          | 0          |
| 3                | 3            | 37           | 202          | 13         | 2          |
| 4                | 0            | 0            | 5            | 15         | 1          |
| 5                | 2            | 0            | 1            | 3          | 2          |
| <b>Total (N)</b> | <b>1,599</b> | <b>799</b>   | <b>294</b>   | <b>32</b>  | <b>6</b>   |

## 2. Additional details on methods

### *Inflation adjustment*

Cost are given in 2010 constant USD. Even though inflating to the most recent year for which a Consumer Price Index (CPI) value is available is standard methodology, in the case of the healthcare cost in South Africa, the use of the general CPI for adjusting for inflation the expected value of a past cost analysis has its limit. Healthcare costs do not follow the general CPI, since salaries are subject to separate negotiations and drug prices (especially for antiretrovirals) have undergone dramatic downward developments since 2010. We think that inflating costs over a total of eight years (from 2006 to 2014) would have exaggerated them and render the final cost figures close to useless.

### *Model calculations*

Standard methodology (Drummond 2005) suggests that the choice of health states in a health-state transition model be reflective of important differences in disease progression, or healthcare utilization and cost, or both, in order to best represent survival and cost associated with the disease or an intervention against it. In analysing the workplace data to decide on the number and definition of health states, we found differences in separations (morbidity and mortality) and promotion rates

between job grades and age groups in all employees; and differences in incidence and separations between job grades, genders and age groups in HIV positive employees, as well as in absenteeism and cost between HIV-positive employees with different CD4 cell count levels. This necessitated the number of categories that we used in the model, and which are given in more detail below.

## Nomenclature

|   |                           |
|---|---------------------------|
| Model cycle   | $t$                       |
| Calendar year   | $y$                       |
| CD4-count defined health state                                  | $s$ for $s = 1 \dots 5$   |
| Job grade   | $j$ for $j = 1 \dots 6$   |
| Age group   | $a$ for $a = 1 \dots 3$   |
| Gender  | $g$ for $g = 1, 2$        |
| Recruits/ retrenchees <sup>12</sup>                             | $R$                       |
| - HIV-positive recruits/ retrenchees                            | $R^+$                     |
| - HIV-negative recruits/ retrenchees                            | $R^-$                     |
| Total required workforce in year $y$                            | $N_y$                     |
| Total workforce in time step $t$                                | $N_t$                     |
| Separation rate per individual                                  | $d_m$ for $m = 1 \dots 6$ |
| Total number of separations                                     | $D_m$ for $m = 1 \dots 6$ |
| - non-HIV related separations                                   |                           |
| - Death/ ill-health retirement (non-HIV related)                | $D_1$                     |
| - Non-HIV disability  | $D_2$                     |
| - Other (dismissed in absentia, etc; non-HIV related)           | $D_3$                     |
| - HIV-related separations                                       |                           |
| - Death/ ill-health retirement (HIV-related)                    | $D_4$                     |
| - HIV disability  | $D_5$                     |
| - Other (dismissed in absentia, etc; HIV-related)               | $D_6$                     |
| Retirees  | $E$                       |
| HIV prevalence in recruits                                      | $P_R$                     |
| Susceptibles -total   | $S$                       |
| HIV incidence in year $y$                                       | $ir$                      |
| Promotion rate from job grade $j$ into job grade $j+1$ per year | $pr$                      |
| Aging rate from age group $a$ into age group $a+1$ per year     | $ar$                      |
| Infecteds -Total  | $I$                       |
| - untested  | $I_u$                     |
| - without care  | $I_n$                     |
| - in Wellness care  | $I_w$                     |

---

<sup>12</sup> If the workforce is set to be reduced during one year, the resulting number of recruits will be negative, signifying the number of people who will be retrenched, rather than recruited, during this year.

|   |                |               |
|---|----------------|---------------|
| - on first-line ART   | $I_{a1}$       |               |
| - in first-line failure   | $I_{ax1}$      |               |
| - on second-line ART  | $I_{a2}$       |               |
| - in second -line failure   | $I_{ax2}$      |               |
| - on any type of ART ( $I_{a1}$ , $I_{a2}$ , $I_{ax1}$ , or $I_{ax2}$ )   |                | $I_a$         |
| - not on ART ( $I_u$ , $I_n$ , or $I_{aw}$ )  | $I_{na}$       |               |
| Yearly incremental coverage with  |                |               |
| - testing   | $C_t$          |               |
| - Wellness care from no care  | $C_{n,w}$      |               |
| - ART from no care  | $C_{n,a1}$     |               |
| - ART from Wellness   | $C_{w,a1}$     |               |
| - first-line ART from first-line treatment failure  | $C_{ax1,a1}$   | <sup>13</sup> |
| - second-line ART from first-line treatment failure   | $C_{ax1,a2}$   |               |
| Transitions from CD4 cell count-defined health state $s$ into health state $s-x$ or $s+x$ , where $x = 1 \dots 4$ <sup>14</sup> |                |               |
| Transition probability  | $tp$           |               |
| Treatment failure   | $tf$           |               |
| - first-line failure  | $tf_{a1}$      |               |
| - second-line failure   | $tf_{a2}$      |               |
| Loss to follow-up from  | $l_{fu}$       |               |
| - Wellness care   | $l_{fu_w}$     |               |
| - first-line treatment  | $l_{fu_{a1}}$  |               |
| - second-line treatment   | $l_{fu_{a2}}$  |               |
| - first-line failure  | $l_{fu_{ax1}}$ |               |
| - second-line failure   | $l_{fu_{ax2}}$ |               |
| Total inpatient cost  | $IC$           |               |
| - of patients on any type of ART ( $I_{a1}$ , $I_{a2}$ , $I_{ax1}$ , or $I_{ax2}$ )   | $IC_a$         |               |
| - of patients not on ART ( $I_u$ , $I_n$ , or $I_{aw}$ )  | $IC_{na}$      |               |
| Total outpatient cost   | $OC$           |               |
| - of patients on any type of ART ( $I_{a1}$ , $I_{a2}$ , $I_{ax1}$ , or $I_{ax2}$ )   | $OC_a$         |               |
| - of patients not on ART ( $I_u$ , $I_n$ , or $I_{aw}$ )  | $OC_{na}$      |               |
| Total absenteeism cost  | $AC$           |               |
| Mean days of absenteeism  | $AD$           |               |
| - of patients on any type of ART ( $I_{a1}$ , $I_{a2}$ , $I_{ax1}$ , or $I_{ax2}$ )   | $AD_a$         |               |
| - of patients not on ART ( $I_u$ , $I_n$ , or $I_{aw}$ )  | $AD_{na}$      |               |
| Salary  |                |               |
| - daily salary  | $S_d$          |               |

<sup>13</sup> A small proportion (default value: 0.1%) of Infecteds in first-line treatment failure are assumed to move back to successful first-line treatment as a result of their viral load being re-suppressed after intensified adherence counselling and an improvement in adherence

<sup>14</sup> Despite  $s$  being included as a subscript to all transition probabilities, the transition probabilities are specific to the type of care

|   |                  |
|---|------------------|
| - annual salary   | S <sub>a</sub>   |
| Incremental death benefits of HIV+ over HIV- employees        | MB               |
| Incremental disability benefits of HIV+ over HIV- employees   | DB               |
| Number of annual salaries used in the calculation of benefits |                  |
| - in case of death of an employee                             | MY               |
| - in case of disability of an employee                        | DY               |
| Total training and recruitment cost                           | TRC              |
| Annual per employee training cost                             | C <sub>T</sub>   |
| Annual per employee recruitment cost                          | C <sub>R</sub>   |
| Total ART cost  | TxC              |
| Annual per employee ART cost                                  | C <sub>ART</sub> |

## Equations

### 1. Recruits/ retrenchees<sup>15</sup> (R)

#### a) All recruits/ retrenchees

Recruits/ retrenchees in cycle t+1 (in specific job grade, age and gender group) = (Workforce required in year y + all separations in cycle t + all retirements in cycle t - current workforce in cycle t) \* proportion of required workforce in year y that needed in job grade \* proportion of workforce in cycle t that is of this gender, age, and job grade out of all workforce in this job grade in cycle t

$$R_{t+1}(a,g,j)^{16} = (N_y + \sum D_{1...6t} + E_t - N_t) * N_y(j) / N_y * N_t(a,g,j) / N_t(j)$$

(Equation 1.1)

#### b) HIV-positive recruits/ retrenchees (R<sup>+</sup>)

HIV-positive recruits/ retrenchees in cycle t+1 = Recruits/ retrenchees in cycle t+1 \* prevalence in recruits<sup>17</sup> in year y (all in cycle t; all for the relevant age-, job grade- and gender-specific cohort)

$$R^+_{t+1}(s,a,g,j) = R_{t+1}(s,a,g,j) * P_R(a,g,j^vi,y)$$

(Equation 1.2)

#### c) HIV-negative recruits/ retrenchees (R<sup>-</sup>)

HIV-negative recruits/ retrenchees in cycle t+1 = Recruits/ retrenchees in cycle t+1 - HIV-positive recruits/ retrenchees in cycle t+1 (all in cycle t; all for the relevant age-, job grade- and gender-specific cohort)

<sup>15</sup> If the workforce is set to be reduced during one year, the resulting number of recruits will be negative, signifying the number of people who will be retrenched, rather than recruited, during this year.

<sup>16</sup> For each parameter, variables in brackets denote the categories that the parameter was stratified by. Parameters without variables in brackets denote the total population or rate across all categories.

<sup>17</sup> If the number of recruits is positive in a year, prevalence in recruits is based on our analysis of workforce prevalence data (by year, gender and job grade); if it is negative (ie, retrenchees are being calculated), prevalence in recruits is based on general workforce prevalence in the model in the same year (by year, age, gender and job grade)

$$R_{t+1}^{-}(a,g,j) = R_{t+1}(a,g,j) - R_{t+1}^{+}(a,g,j)$$

(Equation 1.3)

## 2. Susceptibles (S)

Susceptibles in cycle t+1 = Susceptibles in cycle t - HIV incident cases + HIV-ve recruits - non-HIV related separations - promotions to higher job grade - losses to older age group + gains from younger age group + promotions from lower job grade (all in cycle t; all for the relevant age-, job grade- and gender-specific cohort)

$$S_{t+1}(a,g,j) = S_t(a,g,j) - S_t(a,g,j) * ir(s,j,y)/4 + R_{t+1}^{-}(a,g,j) - S_t(a,g,j) * \sum d_{1,2,3}(j) - S_t(a,g,j) * (pr(j,y) + ar(a))/4 + S_t(a-1,g,j) * ar(a-1)/4 + S_t(a,g,j-1) * pr(j-1,y)/4$$

(Equation 2)

### 3a. Untested infected (I<sub>u</sub>)

Untested infected in cycle t+1 = Untested infected in cycle t + (HIV+ve recruits + incident cases in cycle t) \* (1 - testing coverage) - untested infected in cycle t \* testing coverage - HIV related and unrelated separations - promotions to higher job grade - losses to older age group + gains from younger age group + promotions from lower job grade - transitions to lower health states<sup>18</sup> + transitions from higher health states (all in cycle t; all for the relevant health state-, age-, job grade- and gender-specific cohort)

$$I_{ut,t+1}(s,a,g,j) = I_{ut}(s,a,g,j) + (R_{t+1}^{+}(s,a,g,j) + S_t(a,g,j) * ir(s,j,y)/4) * (1-c_t(y)/4) - I_{ut}(s,a,g,j) * c_t(y)/4 - I_{ut}(s,a,g,j) * \sum d_{1...6}(s,j) - I_{ut}(s,a,g,j) * (pr(j,y) + ar(a))/4 + I_{ut}(s,a-1,g,j) * ar(a-1)/4 + I_{ut}(s,a,g,j-1) * pr(j-1,y)/4 - I_{ut}(s,a,g,j) * \sum_{all\ x \geq 1} tp_{u,s,s-x} + \sum_{all\ x \geq 1} I_{ut}(s+x,a,g,j) * tp_{u,s+x,s}$$

(Equation 3.1)

### 3b. Infected without care (I<sub>n</sub>)

Infected without care in cycle t+1 = Infected without care in cycle t + (HIV+ve recruits + incident cases in cycle t) \* testing coverage - coverage with Wellness and ART + infected in Wellness care, first-line ART, first-line treatment failure, second-line ART and second-line treatment failure who are lost to care - HIV related and unrelated separations - promotions to higher job grade - losses to older age group + gains from younger age group + promotions from lower job grade - transitions to lower health states<sup>xiii</sup> + transitions from higher health states (all in cycle t; all for the relevant health state-, age-, job grade- and gender-specific cohort)

<sup>18</sup> In both the untested and the without care populations, transitions between CD4 cell count categories are unidirectional, with the only possible movement (for those who do not stay in the same health state) being to lower health states (see Table 2 in main paper)



$$\begin{aligned}
I_{nt+1}(s,a,g,j) = & I_{nt}(s,a,g,j) + (R^+_t(s,a,g,j) + S_t(a,g,j) * ir(s,j,y)/4) * c_t(y)/4 - I_{nt}(s,a,g,j) * (c_{n,w}(y)/4 + \\
& c_{n,a1}(s,y)/4) \\
& + I_{wt}(s,a,g,j) * ltfu_w(y,g)/4 + I_{a1t}(s,a,g,j) * ltfu_{a1}(y)/4 + I_{ax1t}(s,a,g,j) * ltfu_{ax1}(y)/4 \\
& + I_{a2t}(s,a,g,j) * ltfu_{a2}(y)/4 + I_{ax2t}(s,a,g,j) * ltfu_{ax2}(y)/4 \\
& - I_{nt}(s,a,g,j) * \sum d_{1...6}(s,j) \\
& - I_{nt}(s,a,g,j) * (pr(j,y) + ar(a))/4 + I_{nt}(s,a-1,g,j) * ar(a-1)/4 + I_{nt}(s,a,g,j-1) * pr(j-1,y)/4 \\
& - I_{nt}(s,a,g,j) * \sum_{all\ x \geq 1} tp_{n,s,s-x} + \sum_{all\ x \geq 1} I_{nt}(s+x,a,g,j) * tp_{n,s+x,s}
\end{aligned}$$

(Equation 3.2)

### 3c. Infected and covered by Wellness care ( $I_w$ )

Infected in Wellness care in cycle t+1 = Infected in Wellness care in cycle t + infected without care in cycle t covered with Wellness care - coverage with 1<sup>st</sup> line ART - HIV related and unrelated separations - loss to follow-up - promotions to higher job grade - losses to older age group + gains from younger age group + promotions from lower job grade - transitions to higher and lower health states + transitions from lower and higher health states (all in cycle t; all for the relevant health state-, age-, job grade- and gender-specific cohort)

$$\begin{aligned}
I_{wt+1}(s,a,g,j) = & I_{wt}(s,a,g,j) + I_{nt}(s,a,g,j) * c_{n,w}(y)/4 - I_{wt}(s,a,g,j) * c_{w,a1}(s,y)/4 \\
& - I_{wt}(s,a,g,j) * \sum d_{1...6}(s,j) - I_{wt}(s,a,g,j) * ltfu_w(y,g)/4 \\
& - I_{wt}(s,a,g,j) * (pr(j,y) + ar(a))/4 + I_{wt}(s,a-1,g,j) * ar(a-1)/4 + I_{wt}(s,a,g,j-1) * pr(j-1,y)/4 \\
& - I_{wt}(s,a,g,j) * \sum_{all\ x \geq 1} tp_{w,s,s+x} - I_{wt}(s,a,g,j) * \sum_{all\ x \geq 1} tp_{w,s,s-x} \\
& + \sum_{all\ x \geq 1} I_{wt}(s+x,a,g,j) * tp_{w,s+x,s} + \sum_{all\ x \geq 1} I_{wt}(s-x,a,g,j) * tp_{w,s-x,s}
\end{aligned}$$

(Equation 3.3)

### 3d. Infected and covered by 1<sup>st</sup> line ART ( $I_{a1}$ )

Infected on 1<sup>st</sup> line ART in cycle t+1 = Infected on 1<sup>st</sup> line ART in cycle t + infected without care in cycle t covered with 1<sup>st</sup> line ART + infected in Wellness care in cycle t covered with 1<sup>st</sup> line ART - 1<sup>st</sup> line treatment failure - HIV related and unrelated separations - loss to follow-up - promotions to higher job grade - losses to older age group + gains from younger age group + promotions from lower job grade - transitions to higher and lower health states + transitions from lower and higher health states (all in cycle t; all for the relevant health state-, age-, job grade- and gender-specific cohort)

$$\begin{aligned}
I_{a1t+1}(s,a,g,j) = & I_{a1t}(s,a,g,j) + I_{nt}(s,a,g,j) * c_{n,a1}(s,y)/4 + I_{wt}(s,a,g,j) * c_{w,a1}(s,y)/4 - I_{a1t}(s,a,g,j) * tf_{a1}(y)/4 \\
& - I_{a1t}(s,a,g,j) * \sum d_{1...6}(s,j) - I_{a1t}(s,a,g,j) * ltfu_{a1}(y)/4 \\
& - I_{a1t}(s,a,g,j) * (pr(j,y) + ar(a))/4 + I_{a1t}(s,a-1,g,j) * ar(a-1)/4 + I_{a1t}(s,a,g,j-1) * pr(j-1,y)/4 \\
& - I_{a1t}(s,a,g,j) * \sum_{all\ x \geq 1} tp_{a1,s,s+x} - I_{a1t}(s,a,g,j) * \sum_{all\ x \geq 1} tp_{a1,s,s-x} \\
& + \sum_{all\ x \geq 1} I_{a1t}(s+x,a,g,j) * tp_{a1,s+x,s} + \sum_{all\ x \geq 1} I_{a1t}(s-x,a,g,j) * tp_{a1,s-x,s}
\end{aligned}$$

(Equation 3.4)

### 3e. Infected in 1<sup>st</sup> line treatment failure ( $I_{ax1}$ )

Infected in 1<sup>st</sup> line treatment failure in cycle t+1 = Infected in 1<sup>st</sup> line treatment failure in cycle t + infected on 1<sup>st</sup> line treatment in cycle t \* 1<sup>st</sup> line treatment failure rate - coverage with 2<sup>nd</sup> line ART - re-coverage with 1<sup>st</sup> line ART - HIV related and unrelated separations - loss to follow-up - promotions to higher job grade - losses to older age group + gains from younger age group + promotions from lower job grade - transitions to higher and lower health states + transitions from lower and higher health states (all in cycle t; all for the relevant health state-, age-, job grade- and gender-specific cohort)

$$\begin{aligned}
 I_{ax1t+1}(s,a,g,j) = & I_{ax1t}(s,a,g,j) + I_{a1t}(s,a,g,j) * tf_{a1}(y)/4 - I_{ax1t}(s,a,g,j) * (c_{ax1,a2}(y)/4 + c_{ax1,a1}(y)/4) \\
 & - I_{ax1t}(s,a,g,j) * \sum_{d_{1...6}}(s,j) - I_{ax1t}(s,a,g,j) * ltfu_{ax1}(y)/4 \\
 & - I_{ax1t}(s,a,g,j) * (pr(j,y) + ar(a))/4 + I_{ax1t}(s,a-1,g,j) * ar(a-1)/4 + I_{ax1t}(a,g,j-1) * pr(j-1,y)/4 \\
 & - I_{ax1t}(s,a,g,j) * \sum_{all\ x \geq 1} tp_{ax1,s,s+x} - I_{ax1t}(s,a,g,j) * \sum_{all\ x \geq 1} tp_{ax1,s,s-x} \\
 & + \sum_{all\ x \geq 1} I_{ax1t}(s+x,a,g,j) * tp_{ax1,s+x,s} + \sum_{all\ x \geq 1} I_{ax1t}(s-x,a,g,j) * tp_{ax1,s-x,s}
 \end{aligned}$$

(Equation 3.5)

### 3f. Infected and covered by 2<sup>nd</sup> line ART ( $I_{a2}$ )

Infected on second line ART in cycle t+1 = Infected on 2<sup>nd</sup> line ART in cycle t + 1<sup>st</sup> line treatment failure covered with 2<sup>nd</sup> line treatment - 2<sup>nd</sup> line treatment failure - HIV related and unrelated separations - loss to follow-up - promotions to higher job grade - losses to older age group + gains from younger age group + promotions from lower job grade - transitions to higher and lower health states + transitions from lower and higher health states (all in cycle t; all for the relevant health state-, age-, job grade- and gender-specific cohort)

$$\begin{aligned}
 I_{a2t+1}(s,a,g,j) = & I_{a2t}(s,a,g,j) + I_{ax1t}(s,a,g,j) * c_{ax1,a2}(y)/4 - I_{a2t}(s,a,g,j) * tf_{a2}(y)/4 \\
 & - I_{a2t}(s,a,g,j) * \sum_{d_{1...6}}(s,j) - I_{a2t}(s,a,g,j) * ltfu_{a2}(y)/4 \\
 & - I_{a2t}(s,a,g,j) * (pr(j,y) + ar(a))/4 + I_{a2t}(s,a-1,g,j) * ar(a-1)/4 + I_{a2t}(s,a,g,j-1) * pr(j-1,y)/4 \\
 & - I_{a2t}(s,a,g,j) * \sum_{all\ x \geq 1} tp_{a2,s,s+x} - I_{a2t}(s,a,g,j) * \sum_{all\ x \geq 1} tp_{a2,s,s-x} \\
 & + \sum_{all\ x \geq 1} I_{a2t}(s+x,a,g,j) * tp_{a2,s+x,s} + \sum_{all\ x \geq 1} I_{a2t}(s-x,a,g,j) * tp_{a2,s-x,s}
 \end{aligned}$$

(Equation 3.6)

### 3g. Infected in 2<sup>nd</sup> line treatment failure ( $I_{ax2}$ )

Infected in 2<sup>nd</sup> line treatment failure in cycle t+1 = Infected in 2<sup>nd</sup> line treatment failure in cycle t + infected on 2<sup>nd</sup> line treatment in cycle t \* 2<sup>nd</sup> line treatment failure rate - HIV related and unrelated separations - loss to follow-up - promotions to higher job grade - losses to older age group + gains from younger age group + promotions from lower job grade - transitions to higher and lower health states + transitions from lower and higher health states (all in cycle t; all for the relevant health state-, age-, job grade- and gender-specific cohort)

$$I_{ax2t+1}(s,a,g,j) = I_{ax2t}(s,a,g,j) + I_{a2t}(s,a,g,j) * tf_{a2}(y)/4$$

$$\begin{aligned}
& - I_{ax2t}(s,a,g,j) * \sum d_{1...6}(s,j) - I_{ax2t}(s,a,g,j) * l_{fu_{ax2}}(y)/4 \\
& - I_{ax2t}(s,a,g,j) * (pr(j,y) + ar(a))/4 + I_{ax2t}(s,a-1,g,j) * ar(a-1)/4 + I_{ax2t}(s,a,g,j-1) * pr(j- \\
& 1,y)/4 \\
& - I_{ax2t}(s,a,g,j) * \sum_{all \ x \geq 1} tp_{ax2,s,s+x} - I_{ax2t}(s,a,g,j) * \sum_{all \ x \geq 1} tp_{ax2,s,s-x} \\
& + \sum_{all \ x \geq 1} I_{ax2t}(s+x,a,g,j) * tp_{ax2,s+x,s} + \sum_{all \ x \geq 1} I_{ax2t}(s-x,a,g,j) * tp_{ax2,s-x,s}
\end{aligned}$$

*(Equation 3.7)*

#### 4. Total separations (D)

##### a) For HIV-negative employees

$$\sum_{all \ j} D_{m1,2,3t}(j) = S_t(j) * \sum d_{1,2,3}(j)$$

*(Equation 4.1)*

##### b) For HIV-positive employees

$$\sum_{all \ j \ and \ s} D_{m1...6t}(s) = I_t(s) * \sum d_{1...6}(s,j)$$

*(Equation 4.2)*

#### 5. Cost

##### a) Inpatient cost (IC)

$$IC = \sum_{all \ s} I_a(s) * IC_a(s) + \sum I_{na}(s) * IC_{na}(s)$$

*(Equation 5.1)*

##### b) Outpatient cost (OC)

$$OC = \sum_{all \ s} I_a(s) * OC_a(s) + \sum I_{na}(s) * OC_{na}(s)$$

*(Equation 5.2)*

##### c) Absenteeism cost (AC)

$$AC = \sum_{all \ j \ and \ s} I_a(j,s) * AD_a(s) * Sd(j) + \sum I_{na}(j,s) * AD_{na}(s) * Sd(j)$$

*(Equation 5.3)*

##### d) Incremental replacement cost due to HIV

###### i. Death benefits (MB)

$$MB = \sum_{all \ j \ and \ s} I(j,s) * (d_4(s) - d_1(j))^{19} * Sa(j) * MY$$

*(Equation 5.4)*

###### ii. Disability benefits (DB)

$$DB = \sum_{all \ j \ and \ s} I(j,s) * (d_5(s) - d_2(j)) * Sa(j) * DY$$

*(Equation 5.5)*

###### iii. Training and recruitment cost (TRC) (only in cycles in which $R_t$ is >0)

$$TRC = \sum_{all \ j \ and \ s} I(j,s) * (d_{4,5,6}(s) - d_{1,2,3}(j)) * (C_T(j) + C_R(j))$$

*(Equation 5.6)*

##### e) ART cost (TxC)

---

<sup>19</sup> In order to calculate the incremental separations of HIV-positive employees over HIV-negative employees, we subtract the separation rates in HIV-negative employees from those in HIV-positive employees

$$TxC = \sum_{\text{all } s} I_a(s) * C_{ART}$$

*(Equation 5.7)*

## References

1. Drummond 2005: Drummond MF, Sculpher MJ, Torrance GW, O'Brien BJ, Stoddart GL (2005) Methods for the Economic Evaluation of Health Care Programmes. New York: Oxford University Press, 3 ed.
2. Ingle SM (2010) Modelling waiting times for HIV antiretroviral therapy in South Africa: Patient management, outcomes and treatment rationing strategies in the Free State Province. PhD thesis, University of Bristol.
3. Huber A, Pienaar J, Innes C, Felix M, Churchyard GJ, Hoffmann CJ, Fielding KL, Latka MH (2011) Impact of universal VCT on population HIV incidence within a cohort of South African coal miners. International AIDS Society Conference 2011

## 11 Conclusions

This thesis set out to demonstrate how the results of cost and outcome analysis in routine care can be used in a budget impact model that informs policy makers at the national government level about the budget and programmatic consequences of a change in policies, with an application to the national antiretroviral treatment programme in South Africa. The following chapter summarises the findings of the thesis, its contributions to HIV policy in South Africa, the limitations inherent in the employed methods, and topics that warrant further research in the area of HIV programming and budgeting in South Africa.

### ***11.1 Overall findings of the thesis***

The review of previous budget impact analyses of HIV interventions and modelled economic analyses of ART (Chapter 4) found that while previous models had been quite detailed in the treatment of outcomes, this amount of detail was not mirrored by the cost categories used, with most analyses stratifying cost by disease stage and treatment regimen only. The reviewed analyses for sub-Saharan Africa were a case in point in that interest in the cost of ART provision in this area started early, before data from in-country programmes was available, with the first analyses based on assumptions extrapolated from high-income countries which were only gradually replaced by locally collected and relevant cost and outcomes data. As a result, the range of results was wide even for the same outcome parameter, depending on the variation in costing and modelling methods but also representing an evolution in the availability and use of appropriate local cost data.

In summary, the review of budget impact analyses showed that 1.) a budget impact analysis is useless without a clearly identified payer and a circumscribed budget; 2.) the budget impact of most interventions will be positive, unless specific measures are included that decrease costs; 3.) the target population for budget impact analyses of antiretroviral treatment that have a period of analysis of more than 1 year needs to be informed by the current cohort of identified HIV-positive people in a country or region plus additionally eligible and identified cases; 4.) budget impact analyses of both prevention/testing interventions and ART from a public-sector perspective need to take into account more than just the resource use and cost of the intervention under analysis in order to capture the full impact on the budget. The review of modelled economic analyses of ART indicated that 1.) the number of health states should be enough to include all those that represent a clear difference with regards to cost, survival in care, or both; 2.) differences in results between analyses cannot be interpreted without information on break-down of both input costs and cost results by item (eg, staff, drugs, diagnostics, inpatient vs. outpatient costs); 3.) where possible, data regarding cost and outcomes need to come from the same setting in order to uphold the claim that these resources led to these outcomes; and 4.) the contention that HAART saves economic resources might be a result of effectiveness studies conducted in the 'window of opportunity' phase in 1996 and 1997, when HAART had just been registered.

One of the additional factors considered in the review was the potential for the cost of ART to vary by geographical location and the type of population served. In our analysis of the outpatient and inpatient cost of ART provision in an urban and a semiurban clinic in South Africa (paper 1), we showed that while inpatient cost was much higher in the semiurban setting, average outpatient cost per patient year was nearly identical (despite variation in the distribution of average cost across cost items such as staff and other fixed costs and diagnostic costs, and, to an extent, ARV drug cost). Even though mean total cost (including inpatient and outpatient cost) decreased with increasing CD4 cell counts of patients, the differences between the analysed CD4 cell count categories weren't significant, nor were the differences between clinics. This lends credence to the use of a uniform cost per patient year in the NACM without differentiation by CD4 cell count stratum or clinic location. The analysis of inpatient cost of adults before and after ART initiation in an urban and a rural clinic in South Africa (paper 2) again showed that hospitalisation frequency, length and cost differed by CD4 cell count stratum, location, and ART status - though again not significantly, with results bearing widely overlapping confidence intervals.

Similarly, our analysis of the outpatient cost and outcomes of paediatric ART in two different sites in South Africa (paper 3) showed that the cost of providing ART to children is very close to that of adults, converging after the first year, and being highly dependent on the age distribution and types of regimens used in a clinic population. As a consequence, the NACM uses the same non-drug cost for both adults and children while calculating the cost of ARVs based on children's current age (four age bands) and age at initiation (two age bands). Chapter 8 presents the results of a cost analysis of the in- and outpatient cost of children in their first years of age, stratified by the conditions under which they initiated treatment - either immediately or once they met the standard immunological or clinical criteria of the 2004 WHO guidelines, both in a clinical trial setting; or depending on immunological or clinical criteria in a routine care setting. Even when restricted to healthcare cost only, initiating ART in a child as early as possible after a positive HIV test saves cost over the first year of life. This short analysis did not provide a model input per se but strengthened the evidence base for the inclusion of a policy of Early Paediatric Treatment in the 2010 South African ART guidelines, for which a scale-up function and cost were included in the NACM.

Based on these inputs and a set of epidemiological parameters such as mortality, loss to follow-up and treatment failure rates and transition probabilities from one CD4 cell count-defined health state to another, in 2009/10 the NACM was used to model the size and cost of the South African national ART programme under three possible scenarios: firstly, the existing guidelines, characterised chiefly by adult eligibility at a CD4 cell count of <200 cells/microl; secondly, the full 2010 WHO guidelines with adult eligibility at 350 CD4 cells/ microl; and thirdly, a hybrid scenario which added eligibility at a CD4 of 350 for pregnant women and people co-infected with TB but maintained the original eligibility threshold of CD4 200 for everyone else (chapter 9). We analysed each of these scenarios under the existing unit costs as well as under two additional policies: the task-shifting of ARV prescription from

doctors to nurses, and of ARV dispensing from pharmacists to pharmacy assistants, and the opening of the South African ARV drug market to international competition, with tender prices based on the cheapest internationally available price for each drug formulation, including fixed-dose combinations wherever possible. We found that while implementing the 2010 WHO guidelines would increase total cost over the next two mid-term expenditure framework periods (2010/11 to 2016/17) by 35% to USD 19.1 billion, and the hybrid scenario by 19%, this increase could be more than offset by introducing the two additional policies. In this case, the total cost of the ART programme under the New Guidelines would be 32% less than under the Old Guidelines without FDCs and task-shifting (government's revealed willingness-to-pay), while reaching 14% more patients. Implementing the Full WHO Guidelines would still be 23% less costly than continuing the Old Guidelines, while reaching 23% more patients.

Based in part on this analysis, the South African government introduced the hybrid guidelines as well as Early Paediatric Treatment in April 2010 and the full 2010 WHO guidelines in August 2011, established task shifting, and, using the proposed reference price list, negotiated significant drug price reductions for both the December 2010 and the December 2012 ARV drug tender.

One of the findings of the NACM analysis in 2009 was that the incremental growth in the number of eligible patients as a result of increased immunological thresholds would always be dwarfed by the growth in the number of patients due to incidence and disease progression. With a treatment population expected to reach 5 million adults, or 10% of the adult population, in the next five years, government has started to look for alternatives to exclusive public-sector provision. When analysing the cost benefit of workplace ART provision in a mining company in South Africa (paper 4), using a model that was structurally very similar to the NACM, we found that such a programme is cost-saving over HIV care without ART from the employer perspective, largely due to savings in benefits, absenteeism costs, and inpatient costs. The total undiscounted cost of HIV to the company over 20 years between 2003 and 2022 fell by 5%, and the cost per HIV-positive employee by 14%, through the introduction and scale-up of a company ART programme. Under all examined scenarios, including treatment of family members and universal testing and immediate treatment of the workforce, ART remained 1-12% cheaper than no ART, except when no benefits were paid out to employees leaving the workforce and when absenteeism rates were half of what data suggested.

## ***11.2 Comparison of results with those of recent economic analyses of ART in South Africa***

The cost of the national ART programme has been estimated in the past, as briefly summarised in section 4.5. Most recently, Cleary et al's costing of the National Strategic Plan (NSP) 2007 estimated the cost of providing ART for five years (2007 - 2011) to up to 80% of all adults and children in need to be about USD 2.6 billion in 2009 terms [1], which represents a fraction of our seven-year estimate. Cleary et al's analysis however only included the cost of newly initiated patients, for which fixed

targets set by the NSP were used, totalling roughly 1.4 million patients over this time period. Since our model includes the cost of treating all patients - those initiating between 2010/11 and 2016/17 as well as those already in treatment by the end of 2009/10 -, with between 2.9 and 3.6 million patients, the numbers of patients initiating treatment in our model are higher by far.

Other studies have estimated the impact on the South African programme of increasing the CD4 cell count threshold for ART eligibility to 350 cells/microl. A study by Badri et al in 2006 compared the cost-effectiveness of initiating ART at between 350 and 200 CD4 cells/microl to initiating at above 350 cells/microl or below 200 cells/microl [2]. It found that initiating ART at 200-350 CD4 cells/microl had an incremental cost-effectiveness ratio of USD 616 per quality-adjusted life year gained, leading the authors to suggest that “ART is reasonably cost-effective for HIV-infected patients in South Africa, and most effective if initiated when CD4 count >200/microl” [2]. Based on these data, Cleary in 2009 presented the budget impact of ART initiation at <350 cells/microl in a conference presentation at the 5<sup>th</sup> International AIDS Society Conference in 2009, estimating that the annual cost for the ART programme at this eligibility level would be close to USD 3.2 billion by 2016/17, which closely matches our results [3]. Also in 2009, Walensky et al presented a cost-effectiveness analysis of starting ART in South Africa at below 350 or 200 CD4 cells/microl, finding that an eligibility threshold of 350 cells/microl would lead to a discounted total cost over five years of between USD 9.98 and 12.05 billion over the (unspecified) next 5 years, depending on the level of HIV testing and ART coverage [4]. These results are also very comparable to ours, suggesting convergence in the evidence base available to policy makers.

## **11.3 Contributions of the thesis**

### **11.3.1 Changes in the national ART budget process**

As described in the Introduction, at the outset of our engagement with the South African government in early 2009 the process of setting a budget for the ART programme at the national level was somewhat haphazard, with targets and unit costs set by provinces based on past budgets or assumptions. While strategy such as the National Strategic Plan for HIV and AIDS & STIs 2007-2011 had been based on detailed budget analyses using population data based on epidemiological models, unit costs based on cost analyses, and coverage targets agreed on by policy makers, the annual Conditional Grant budgets that were submitted by the NDoH to Treasury were principally based on provincial plans that contained almost no analysis. The National ART Cost Model added to this the possibility of analysing both national- and provincial-level cost based on detailed data regarding the target population, population remaining in care, and unit costs.

### **11.3.2 Increases in the HIV Conditional Grant budget**

The addition of the National ART Cost Model into the budget planning process gave policy makers in the Department of Health the ability to make the case for additional funding required to increase



eligibility and offer better drugs, while it supplied decision-makers in the National Treasury with the confidence to commit to increasing the HIV Conditional Grant (M. Blecher, personal communication) by 30% over the originally planned amount in 2010/11, and by 100% in 2011/12. Figure 4 summarises the relationship between the originally planned CG amounts, the numbers of patients on ART and total cost of the ART programme projected by the NACM, and the final resulting CG amounts for the financial year 2009/10 and 2011/12.

**Figure 4: Development of HIV Conditional Grant amounts (2009/10 to 2011/12), in comparison to total patient numbers and total ART cost as calculated by NACM**

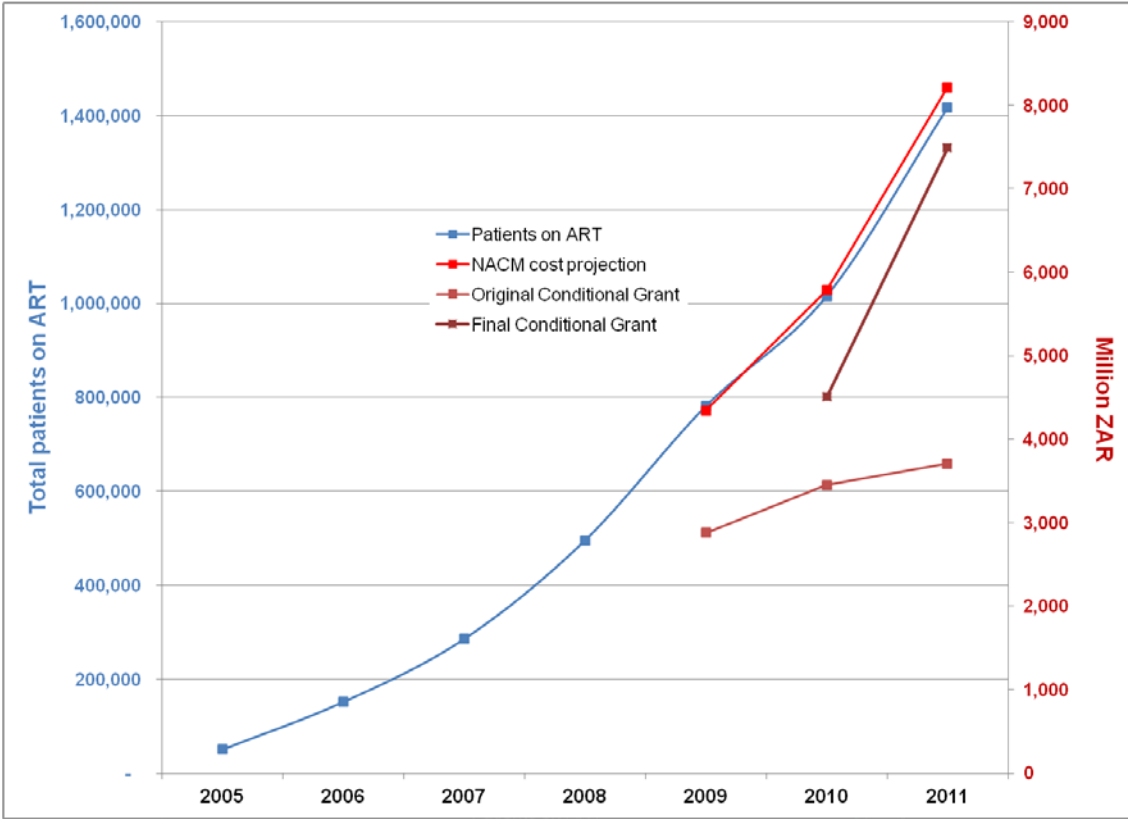

While the NACM and its results played an undeniable role in steadying the hand of the policy makers within the South African government in implementing more expansive guidelines and increased funding for HIV, while increasing programme efficiency through increasing market competition for antiretroviral drugs and enabling lower-level staff cadres to prescribe and dispense ARVs, it is important to note that the NACM was only one of the factors in this process. A main contributor to this change in policy was the strong leadership exerted by the current Minister of Health, Dr Aaron Motsoaledi, and the managers within the NDoH. Work by the Clinton Health Access Initiative was instrumental in making the case for the pegging of tender prices to the lowest internationally available prices, as well as assembling the resulting price reference list. Staff within the Affordable Medicines Directorate within the NDoH led the 2010 tender negotiations that resulted in a decrease of a mean of 50% in the price of single ARVs compared to the 2008 tender, of 18% to 23% in the per-patient cost of

ARV provision, and of the annual cost of the ART programme by 26% [5], just as envisaged in the initial NACM analysis (see Chapter 9).

The HIV Conditional Grant budget kept increasing between the 2012/13 and 2015/16 financial years, again based on the results of the NACM, amongst others, bringing the total increase in the government’s spending on HIV in real terms to 772% over the life of the ART programme (since 2003/4), or 215% since 2008/09, the last year before the NACM was used to define the ART budget (Figure 5) [6].

**Figure 5: Historic and planned government expenditure on HIV (2003/04 to 2016/17)**

Data based on [6], sources: Estimates of Provincial Expenditure/ Estimates of National Expenditure 2004/5 to 2014/15, Medium Term Policy Statements, Division of Revenue Bill/ Acts; all from National Treasury

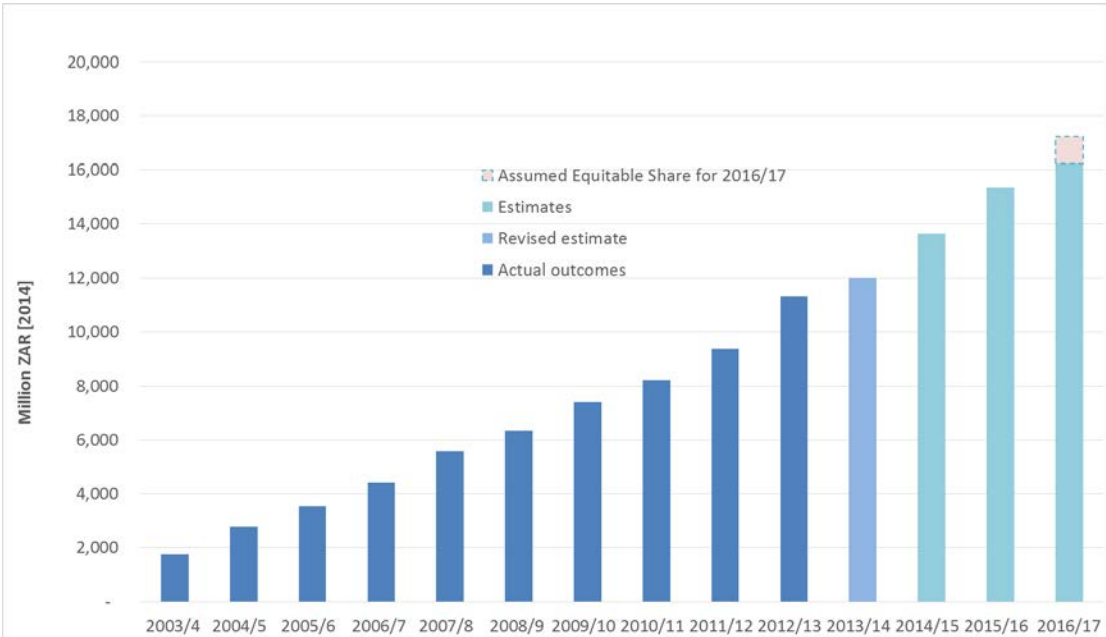

**11.3.3 Further updates to the NACM**

In order to maintain the relevance of the NACM as a budgeting tool, it has been constantly updated to capture new input prices as well as updates to the target population. In 2011, input from the new NSP Model incorporating CD4 cell count stages was used to update the NACM in order to calculate the cost of ART and PMTCT for the National Strategic Plan for HIV, STIs and TB 2012-2016 [7]. In 2013, the treatment cohort that contributed the original data for the transition probabilities for adults had grown so much that we were able to update all probabilities based on data from a sample of 20,496 patients. The size of the sample, more than twice that of the original one, allowed us to stratify all transition probabilities for adults by time on treatment, not only those for first-line treatment, and to add third-line treatment as a type of care. We also added another four years to the projection period so that the model now covers the years 2003/4 to 2020/21, and based the target population on new input from the successor model to the ASSA AIDS model, the Thembisa model, which was set up to

also provide data on the number of people initiating ART under the 2013 WHO guidelines as well as universal treatment [8]. Thembisa as well as the updated version of the NACM were central in the development of the South African HIV and TB Investment Case which investigated the cost and impact of an optimised HIV programme, including all treatment and prevention interventions as well as a number of technical efficiency factors and structural enablers [9]. Finally, in order to fulfil a request from the NDoH and NT, we wrote a manual for the model and trained staff from both departments in the use of the model. This means that the South African government will now be able to do its own ART budget projections going forward. Similarly, a previous version of the Workplace Impact Model (WIM) has been handed over to the company described in Chapter 10, after a manual and training materials had been developed.

#### **11.3.4 Other uses of NACM output**

In contrast to a once-off published cost analysis, the structure of the NACM allows regular updates to input prices and the calculation of an average cost of ART per year and patient type that is relevant to the current moment in time and reflects the maturation of the cohort into adults and children, new and established patients, and into specific first and second line treatment. These time-flexible average cost results have therefore been used in a wide number of other analyses, including in the preparation of all of South Africa's funding proposals to the Global Fund to Fight AIDS, Tuberculosis and Malaria (GFATM) since 2010, an analysis of the cost of HIV prevention and treatment in South Africa until 2031 (AIDS2031) [10], and as inputs for an analysis of the fiscal dimensions of HIV/AIDS in South Africa [11] and for economic analyses of HSV-2 suppressive therapy [12], treatment as prevention [13], and a TDF-containing microbicide [14]. Provincial estimates for KwaZulu-Natal have been used in a broader cost analysis of HIV prevention and treatment in this province [15] as well as in a Public Expenditure Tracking Survey focusing on HIV spending in the province [16]. Results of the model in terms of numbers of patient years per ARV regimen have been used in drug quantification reports compiled by WHO for the years 2009 and 2011.

#### **11.4 Limitations**

There are a number of limitations in the methods used in building and parametrising the NACM as well as the Workplace Impact Model (WIM) which have potential implications for the validity and generalisability of the models' results. Beyond what has been discussed in each paper and chapter, some overarching themes with regards to the conceptual, methodological, structural and parametric uncertainty surrounding this research emerge.

##### **11.4.1 Parametric uncertainty: Choice of data sources and cost parameters**

All inputs to the model were based on data collected in one or two clinics that were chosen based on their accessibility and the availability of data. There was no sampling framework, and the data in terms of average resource use, cost, and clinical outcomes resulting from the analysis might be severely

biased as a result. However, cost and outcomes data used to parametrise the NACM were purposely sourced in the same clinic wherever possible, meaning that the resources used conceivably lead to the outcomes recorded. A possible remedy for this would be to analyse cost and outcomes data across a larger sample of clinics representing a wide geographic spread and all relevant models of care, using efficiency analysis methods such as Data Envelopment Analysis or Stochastic Frontier Analysis. Our input data also do not take into account a possible impact of economies of scale or, as ART continues to be integrated with general chronic healthcare at the primary healthcare level, economies of scope. However, to my knowledge, no analysis so far has found any evidence of economies of scale in ART provision [17].

#### **11.4.2 Methodological uncertainty: Treatment of uncertainty**

Although some of the analyses of inputs presented in Chapter 5 to 8 included the calculation of uncertainty ranges such as confidence intervals, the NACM does not currently accommodate systematic multivariate uncertainty analysis. The presentation of the results of both models was therefore restricted to scenario analysis, as suggested by the ISPOR guidelines discussed in section 2.2. It should also be borne in mind that the model was built on request of government staff who specifically requested that it should be run without recourse to additional software, and by mid-level staff. The NACM has been handed over to such users who have been successfully trained in its methods.

The health-state transition model introduced in Chapter 10, the Workplace Impact Model (WIM) used for the analysis of the cost-benefit of ART provision at the workplace level, included both advanced stochastic fitting methodology as well as a probabilistic sensitivity analysis. This allowed the presentation of results for the main analysis as the median and 5% and 95% percentiles of model runs with good fit, and the systematic examination of the sensitivity of the results to the uncertainty surrounding many of the inputs. While such functionality is certainly desirable for the NACM as well, and might be added in the future (see section 11.5.2), it must be borne in mind that the workplace model had to contend with inputs based on much less data than the NACM, with only 1,149 employees contributing data to the estimation of HIV-relevant parameters in the WIM, as compared to the 9,502 adult patients contributing data to the estimation of parameters in the NACM.

#### **11.4.3 Conceptual uncertainty: The impact of treatment on HIV transmission**

Neither the original version of the NACM nor WIM include an impact of antiretroviral treatment on HIV transmission, an impact that has by now been quantified for discordant couples [18] and at the population level [19] and has been included in a number of modelling exercises of both cost and incidence [20-26]. It has been excluded from the NACM due to the short projection period of the model of six years into the future and its focus on treatment only instead of the entire period of HIV infection. Due to the natural history of HIV infection, during six years any impact of the incremental coverage with ART between scenarios on the incidence of new infections would not likely translate

into a reduction in the number of new patients initiating treatment. It has been excluded from WIM because of the restriction of that model on the workplace of a particular company, where it would need an extremely tight sexual network involving most employees for a reduction in the infectivity of employees to translate in a significant reduction of HIV incidence in the same workforce.

### **11.5 Areas of further research**

Following from the above, there are a number of analyses that could be usefully employed to close the remaining gaps in the analysis of the cost of the national ART programme in South Africa.

#### **11.5.1 Cost and outcome inputs based on randomly selected sample of clinics**

Firstly, averages in the model inputs for cost and outcomes that are currently based on a single clinic, or two clinics, should be replaced by a number of values based on a larger population of clinics across different geographic locations (including rural sites), sizes, and types of care. Such an exercise involving 12 ART clinics in South Africa, though based on a convenience rather than a random sample has been conducted recently, as part of a larger multi-country study involving 161 facilities in five countries, with the average cost across all sites being almost identical to the average cost produced by the NACM for the same year [32]. Data collection from a larger number of randomly selected clinics is planned for the next years, as part of the district-level version of the South African HIV and TB Investment Case. The data collected in this exercise might then also allow for the calculation of marginal, rather than mean, cost, and the full estimation of flexible cost and production functions [33] which might be useful in more geospatially disaggregated analyses of the cost of the South African ART programme [34].

#### **11.5.2 Addition of probabilistic uncertainty analysis**

One of the larger shortfalls of the NACM is the absence of a structure that allows for uncertainty in model estimates to translate into uncertainty around the results and, ultimately, around the decisions based on these results, as described in Chapter 2. While such functionality was never requested from the model's immediate stakeholders, as explained in section 11.4.2, it would greatly improve the stability of the results and the usefulness of the model for other audiences - and, arguably, for the models' immediate clients in government. The availability of parsimonious add-on software has made it possible to add a probabilistic sensitivity analysis to the NACM in the future, similar to the one added to the WIM.

#### **11.5.3 Inclusion of the impact of treatment on HIV transmission**

Under the eligibility criteria under discussion in the model analyses in Chapter 9, an impact of expanded ART coverage on transmission and, via that, the future need for ART did not play a role as due to the natural history of HIV infection any such impact would have taken longer than the six years the model projects for to play out. If however treatment was started at higher eligibility thresholds,

below 500 CD4 cells/ microl or even, under Universal Test and Treat, immediately after HIV diagnosis, the time period between infection and treatment start would potentially become short enough for this impact to become relevant even shortly after the change in guidelines. Since the NACM uses the number of people initiating ART as an input from a separate HIV transmission model (the ASSA AIDS model or, later, the Thembisa model), this impact would have to be captured in the transmission model rather than within the NACM itself. The update to the ASSA AIDS Model, the Thembisa model, was designed to include this relationship. As a result, recent analyses using this model, including the South African HIV and TB Investment Case, replicated the finding from earlier analyses of Universal Testing and Treatment [20,21,26] that scaling up ART at very high population coverage levels can become cost-saving once the prevention effect has been taken into account [9].

#### **11.5.4 Expansion of the scope of analysis to include prevention interventions**

The argument about whether to spend more on treatment or on prevention is almost as old as the first economic analyses of ART [35]. Especially when the strongest argument for the further expansion of treatment is its prevention effect over its beneficial impact on an individual's survival and quality of life, the appropriate comparator for these more expansive eligibility scenarios are other prevention interventions, not just the current treatment guidelines. To this end the South African government commissioned the South African HIV and TB Investment Case which included a number of relevant HIV and TB interventions, including ART (under current guidelines as well as universal testing and treatment), comprehensive condom programming, HIV counselling and testing, medical male circumcision, PMTCT, TB prevention, screening, diagnosis and treatment, as well as interventions for key populations and social behaviour change marketing. The NACM was used together with a suite of local epidemiological and cost models to calculate the cost of each of these interventions at current and optimal levels of coverage and technical efficiency in order to analyse the most efficient mix of interventions in terms of reducing HIV and TB infections and maximising life-years lived [9].

### ***11.6 Policy relevance of research***

#### **11.6.1 There's no doubt the model changed policy...**

Chapter 9 describes the use of the NACM by the South African government to help make decisions about the adoption of the 2009 ART guidelines by the World Health Organization. Due to the above-mentioned new evidence that has evolved especially in terms of the transmission effect of population-level treatment provision, the WHO revised their ART guidelines again in July 2013 [27]. These guidelines included increasing eligibility further, to a threshold of 500 CD4 cells/microl; treating all HIV-positive partners in serodiscordant couples, regardless of CD4 cell count; and reducing laboratory monitoring of ART to one annual viral load and a single CD4 cell count a year after treatment initiation [27]. As mentioned above, the NACM was updated to calculate the cost of these new guidelines, and, as before, the results were used by the Department of Health in motioning for a budget increase and the issue of new guidelines reflecting the 2013 WHO guidelines in early 2015 [28]. At the time of

writing, WHO had just issued another guideline change including Universal Testing and Treatment (or “Test and Offer”, to underline the non-coercive nature of treatment initiation) [29], based on this prevention effect as well as the outcomes of the TEMPRANO trial (and, to a lesser extent, the START trial) which for the first time showed a clear positive impact on the health of people initiating treatment at CD4 cell counts above 500 CD4 cells/microl [30,31]. The cost implications of this potential future guideline change for South Africa have been calculated as part of the South African HIV and TB Investment Case, again using the NACM to calculate the cost of ART provision to up to 6.5 million people in South Africa [9].

### **11.6.2 ...but should it have?**

The relative success of the NACM in supporting the change of HIV policy to allow more people to benefit from ART and access better drugs and in rallying for an increase in the HIV budget throws open the question of whether the reasons to do so were valid. In other words, should policy have been changed based on a single model, especially a model that was subject to all the limitations mentioned in section 2.4?

Firstly, from the perspective of decision makers in the National Department of Health and Treasury, it is important to note that the model was added to a very low baseline in which data-driven analysis was largely absent from the budget and policy planning process for HIV. This does not mean that the NACM does not have to withstand scrutiny, but it certainly contributed to making the budgeting process more transparent and initiated a process of interrogation and clarification between the National Department of Health and other stakeholders in terms of inputs, assumptions, and HIV policy goals.

Secondly, even though the absence of more refined sensitivity analysis does limit the usefulness of the model somewhat, most of the strongest implications of the analysis discussed in Chapter 9 were based on such large cost differences that the recommendations based on the model results would likely be the same had uncertainty been taken into account, especially the finding of cost savings from the opening of the drug market to international (generic) competition and from task-shifting to lower cadres of clinicians.

Thirdly, some of the more central results of the NACM have since been verified by independent analyses. As predicted by the analysis in chapter 9, the 2010 tender negotiations resulted in an average decrease in the price of single antiretroviral drugs compared to the 2008 tender by 50%, in the per-patient cost of ARV provision by 18% to 23%, and in the annual cost of the ART programme by 26%, which might not be such a surprise since both the model and the tender process worked off the same price list of best prices internationally compiled by the Clinton Health Access Initiative in South Africa. A more important validation for a budget impact model, especially one whose results were produced a number of years ago, is how well actual expenditure fits predicted expenditure over the same period. In South Africa, expenditure against only a few of the cost items included in the

NACM can be tracked appropriately, even if only expenditure under the HIV/AIDS Conditional Grant is taken into account. One exception is the spending on antiretroviral drugs which has the advantage of being circumscribed and easy to allocate as the resource is not shared with any other programme or intervention, such as staff or clinic space would be. A recent analysis of antiretroviral drug expenditure for the financial year 2013/14 in South Africa found average expenditure per patient year of R1,571, a number that was within 14% of the average antiretroviral drug cost predicted by the NACM for the same year (R1,377) [36].

The most serious objection against the government's use of the NACM results to increase the budget for antiretroviral treatment is that it is not an economic evaluation model, and only considers ART, not HIV prevention, nor the entire spectrum of other health interventions or even other public policy options. As such, as mentioned in section 2.5, my work on the NACM started from a declared aim of the current South African government - increasing access to and the quality of the country's ART programme in a situation where the sustainability of the programme was threatened by a lack of funding. (Subsequent rounds of guideline changes and concomitant budget increases in South Africa were probably as much dictated by the desire to put recommendations and declarations of international agencies such as WHO and UNAIDS into practice, as by affordability or the domestic policy agenda, but this issue is somewhat beyond the scope of this thesis.)

As stated in section 2.5, the NACM helped decision makers in the South African government do what they had already resolved to do - potentially to the detriment of other programmes and policies. As Figure 6 shows, the rate of growth in the health budget overall and the proportion of the total government budget spent on health has declined in real terms since 2012/13, while the HIV budget has continued to grow both in total terms and as a percentage of the health budget. This could create a situation where HIV spending potentially outcrowds spending on other, possibly equally worthwhile health programmes. The only way to find out would be subject all health programmes to economic evaluations and optimise spending under a given budgetary constraint or willingness-to-pay threshold by allocating resources according to each programme's relative cost effectiveness.



**Figure 6: Total government, health, HIV budgets/ expenditure (2009/10 - 2016/17)**

Data based on [6], sources: Estimates of Provincial Expenditure/ Estimates of National Expenditure 2004/5 to 2014/15, Medium Term Policy Statements, Division of Revenue Bill/ Acts; all from National Treasury. "Total government/ expenditure" includes allocations at national, provincial & local government level; "total health budget/ expenditure" includes DOH allocations at national and provincial level; "HIV budget/ expenditure (NDOH only) includes HIV/AIDS conditional grant allocations to provinces, NDOH allocations, and provinces' own equitable share allocations.

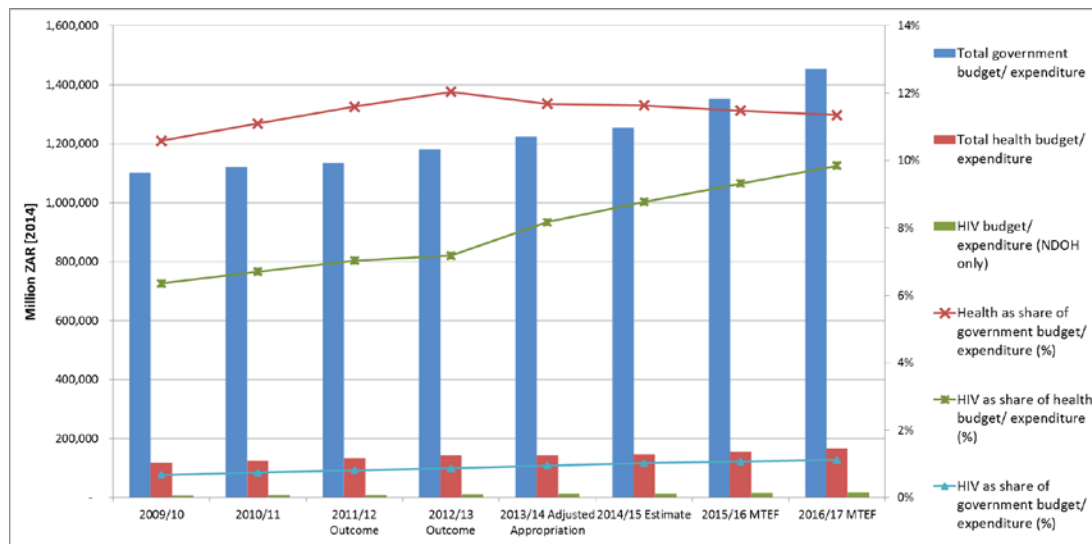

### 11.6.3 A way forward

For the first time in a decade, a number of initiatives are currently under way to improve government priority setting in health, across disease areas, in the public health sector in South Africa.

With regards to optimising government spending on HIV between treatment and prevention interventions, the South African HIV and TB Investment Case went some way towards alleviating possible imbalances between the two areas, by including all currently available treatment and prevention interventions for which there was evidence regarding their effectiveness, calculating their cost-effectiveness using the Thembisa model and a custom-made cost model that included the NACM, ranking them by their cost effectiveness and defining the optimal coverage for each under a given budget envelope, using novel optimisation methodology [9]. The Investment Case has inspired a number of similar government-led exercises in other disease areas, such as maternal and child health and palliative care.

In terms of improving cross-disease allocation of health spending, efforts to create a Health Technology Assessment (HTA) agency or network in South Africa have recently increased, in part building on the successful application of economic evaluation in the area of HIV in the past years. In March 2015, a first meeting of the International Decision Support Initiative funded by NICE-International and the Bill and Melinda Gates Foundation was convened during which the Director-General of the Health Department and the National Treasury's Chief Director for Health and Social Services expressed a strong interest in increasing HTA capacity in South Africa, with the stated aim of

improving the ad-hoc way in which economic analyses are currently done and their results get used by policy makers [37]. While the attending representatives of academic institutions and government departments currently involved in HTA work could not quite agree on the formation of a stand-alone agency, a network of analysts and institutions was formed that will take the development of HTA capacity in the country forward [37].

## References

1. Cleary S: The costs of the National Strategic Plan on HIV and AIDS & STIs 2007-2011. Cape Town 2007
2. Badri M, Cleary S, Maartens G, et al: When to initiate highly active antiretroviral therapy in sub-Saharan Africa? A South African cost-effectiveness study. *Antivir Ther* 2006;11(1):63-72
3. Cleary S: Discussion – the economics of starting ART earlier. 5<sup>th</sup> International AIDS Society Conference 2009, Cape Town
4. Walensky RP, Wolf LL, Wood R et al for the CEPAC (Cost-Effectiveness of Preventing AIDS Complications)-International Investigators: When to Start Antiretroviral Therapy in Resource-Limited Settings. *Ann Int Med* 2009;151:157-166
5. Meyer-Rath G, Pillay Y, Blecher M, Brennan A, Long L, Johnson LF, Moultrie H, Sanne I, Fox M, Rosen S: The impact of a new reference price list mechanism for drugs on the total cost of the national antiretroviral treatment programme in South Africa 2011 to 2017. Abstract no. 621 (oral presentation), South African AIDS Conference 2011
6. Ndlovu N, Meyer-Rath G: Reflecting on health, HIV/AIDS and TB budgets and services in South Africa: Review of the 2014 South African National Budget. CEGAA/ HE<sup>2</sup>RO Budget Policy Brief 6, 2014
7. South African National Council: National Strategic Plan on HIV, STIs and TB 2012-2016. Pretoria, December 2011
8. Johnson L: THEMBSA version 1.0: A model for evaluating the impact of HIV/AIDS in South Africa. Centre for Infectious Disease Epidemiology and Research working paper. February 2014
9. Meyer-Rath G, Chiu C, Johnson L, Schnippel K, Guthrie T, Magni S, Pillay Y, Abdullah F, Kiwango E, on behalf of the Investment Case Task Team and Steering Committee: South Africa's Investment Case – What are the country's "best buys" for HIV and TB? Satellite session, 7<sup>th</sup> South African AIDS Conference 2015
10. Aids2031 Costs and Financing Working Group: The Long-Term Costs of HIV/AIDS in South Africa. Washington, DC: Results for Development Institute; 2010.
11. Lule E, Haacker M: The Fiscal Dimension of HIV/AIDS in Botswana, South Africa, Swaziland, and Uganda. The World Bank, 2012
12. Vickerman P, Devine A, Foss A, Delany-Moretlwe S, Mayaud P, Meyer-Rath G: The Cost-Effectiveness of Herpes Simplex Virus-2 Suppressive Therapy With Daily Aciclovir for Delaying HIV Disease Progression Among HIV-1-Infected Women in South Africa. *Sex Trans Dis* 38(12):1-9 (2011)
13. Eaton JW, Menzies NA, Stover J, Cambiano V, Chindelevitch L, et al: Health benefits, costs, and cost-effectiveness of earlier eligibility for adult antiretroviral therapy and expanded treatment coverage: a combined analysis of 12 mathematical models. *Lancet Global Health* (online publication ahead of print, doi: 0.1016/S2214-109X(13)70172-4) (2013)
14. Terris-Prestholt F, Foss AM, Cox AP, Heise L, Meyer-Rath G, Delany-Moretlwe S, Mertenskoetter T, Rees H, Vickerman P, Watts CH: Cost-effectiveness of tenofovir gel in urban South Africa: model projections of HIV impact and threshold product prices. *BMC Inf Dis*, 14:14 (2014)
15. Kripke K, Mayise T, Palmer E, Forsythe S, Shezi S, Guthrie T, Khoza N. Impact and Cost of HIV/AIDS Prevention and Treatment in Kwazulu-Natal, South Africa 2011-2025. Washington, DC: Futures Group, Health Policy Initiative, Costing Task Order (2013)

16. Osewe P: Barriers to Efficiency in Public Spending for HIV/AIDS: Findings from Kwa-Zulu Natal, South Africa. Presentation at International Multi-Stakeholder Consultation on National AIDS Programmes: Enhancing Effectiveness, and Efficiency and Social Sustainability. Nairobi, Kenya, 19-20 April 2012
17. Siapka M, Remme M, Obure CD, Maier CB, Dehne KL, Vassall A: Is there scope for cost savings and efficiency gains in HIV services? A systematic review of the evidence from low- and middle-income countries. *Bull World Health Organ* 92:499–511 (2014)
18. Cohen M, Chen YQ, McCauley M, Gamble T, Hosseinipour MC, et al. Prevention of HIV-1 infection with early antiretroviral therapy. *N Engl J Med* 365:493-505 (2011)
19. Tanser F, Bärnighausen T, Grapsa E, Zaidi J, Newell ML : High Coverage of ART Associated with Decline in Risk of HIV Acquisition in Rural KwaZulu-Natal, South Africa. *Science* 339, 966-70 (2013)
20. Granich RM, Gilks CF, Dye C, De Cock KM, Williams BG: Universal voluntary HIV testing with immediate antiretroviral therapy as a strategy for elimination of HIV transmission: a mathematical model. *Lancet* 373: 48–57 (2009)
21. Hontelez JAC, de Vlas SJ, Tanser F, Bakker R, Bärnighausen T, et al. The impact of the new WHO antiretroviral treatment guidelines on HIV epidemic dynamics and cost in South Africa. *PLoS ONE* 6: e21919. doi:10.1371/journal.pone.0021919 (2011)
22. Bärnighausen T, Bloom DE, Humair S: Economics of antiretroviral treatment vs. circumcision for HIV prevention. *PNAS* 109(52):21271-6 (2012)
23. Wagner BG, Blower S: Universal Access to HIV Treatment versus Universal ‘Test and Treat’: Transmission, Drug Resistance & Treatment Costs. *PLoS ONE* 7(9): e41212. doi:10.1371/journal.pone.0041212 (2012)
24. Dodd PJ, Garnett GP, Hallett TB: Examining the promise of HIV elimination by ‘test and treat’ in hyperendemic settings. *AIDS* 13;24(5):729-35 (2010)
25. Hallett TB, Baeten JM, Heffron R, Barnabas R, de Bruyn G, et al. Optimal Uses of Antiretrovirals for Prevention in HIV-1 Serodiscordant Heterosexual Couples in South Africa: A Modelling Study. *PLoS Med* 8(11): e1001123. doi:10.1371/journal.pmed.1001123 (2011)
26. Eaton JW, Menzies NA, Stover J, Cambiano V, Chindelevitch L, et al: Health benefits, costs, and cost-effectiveness of earlier eligibility for adult antiretroviral therapy and expanded treatment coverage: a combined analysis of 12 mathematical models. *Lancet Global Health*, [http://dx.doi.org/10.1016/S2214-109X\(13\)70172-4](http://dx.doi.org/10.1016/S2214-109X(13)70172-4) (2013)
27. World Health Organization. Consolidated guidelines on the use of antiretroviral drugs for treating and preventing HIV infection. Recommendations for a public health approach. Geneva, June 2013
28. National Department of Health, South Africa: National Consolidated Guidelines for the Prevention of Mother-to-Child Transmission of HIV (PMTCT) and the management of HIV in Children, Adolescents and Adults. Pretoria, April 2015.
29. World Health Organization. Guideline on when to start antiretroviral therapy and pre-exposure prophylaxis for HIV. Geneva, September 2015.
30. INSIGHT START Study Group: Initiation of Antiretroviral Therapy in Early Asymptomatic HIV Infection. *N Engl J Med* (online publication ahead of print), DOI: 10.1056/NEJMoa1506816 (2015)
31. Danel C, Moh R, Gabillard D, Badje A, Le Carrou J, Kouame GM, Ntakpe JB, Menan H, Eholie SP, Anglaret X: Early ART and IPT in HIV-infected African adults with high CD4 count (Temprano trial). 2015 Conference on Retroviruses and Opportunistic Infections (CROI), Seattle, USA, abstract 115LB, 2015.
32. Over M, Schneider MT, Velayudhan T: Explaining the variation in on-site AIDS treatment costs: the MATCH study of 161 facilities from five countries. *Lancet* 381,S106 (2013)
33. Meyer-Rath G, Over M (2012) HIV Treatment as Prevention: Modelling the Cost of Antiretroviral Treatment—State of the Art and Future Directions. *PLoS Med* 9(7): e1001247. doi:10.1371/journal.pmed.1001247
34. Meyer-Rath G, Over M, Klein DJ, Bershteyn A: The Cost and Cost-Effectiveness of Alternative Strategies to Expand Treatment to HIV-Positive South Africans: Scale Economies and Outreach

Costs. Center for Global Development Working Paper No. 401/ Health and Development Discussion Paper No. 17 (April 2015)

35. Creese A, Floyd K, Alban A, Guinness L: Cost-effectiveness of HIV/AIDS interventions in Africa: a systematic review of the evidence. *Lancet*; 359: 1635–42 (2002)
36. Surgey G: South African Expenditure on ART: Financing of ARVs in 2013/14. Abstract, 12<sup>th</sup> AIDS Impact conference, July 28-31 2015, Amsterdam
37. PRICELESS SA: First Meeting of International Decision Support Initiative (ISDI) and sub-Saharan African Healthcare Networking Project. Meeting report, Johannesburg, May 2015