

LONDON  
SCHOOL *of*  
HYGIENE  
& TROPICAL  
MEDICINE



# **Exploring the contribution of new genetic markers of drug resistance in human malaria parasites**

**Gisela Cristina Lourenço Henriques**

Thesis submitted in accordance with the requirements for the degree Doctor of Philosophy

**University of London**

**May, 2015**

**Department of Immunology and Infection  
Faculty of Faculty of Infectious and Tropical Diseases  
London School of Hygiene & Tropical Medicine**

Funded by Fundação para a Ciência e Tecnologia (FCT) of Portugal  
(grant number SFRH/BD/63129/2009)

Supervisors: Dr. Colin Sutherland

Dr. Rachel Hallett

London School of Hygiene and Tropical Medicine, UK

Dr. Pedro Cravo

Universidade Federal de Goiás, Brazil

I, Gisela Cristina Lourenço Henriques, confirm that the work presented in this thesis is my own. Where information has been derived from other sources, I confirm that this has been indicated in the thesis.

# ABSTRACT

Antimalarial drugs remain as one of the most powerful tools in the fight against malaria with artemisinin derivatives now standing as the cornerstone of anti-malarial drug therapy. Unfortunately, evidence of delayed *in vivo* parasite clearance after artemisinin treatment is accumulating on the Thai-Cambodian border and in nearby countries. A better understanding of the mechanisms of artemisinin (ART) resistance may contribute to the development and validation of new tools for the surveillance of resistance.

One promising approach to identifying candidate genetic markers of ART resistance is genetic analysis of drug-pressured mutants of the rodent malaria parasite *Plasmodium chabaudi*. This experimental system has identified a number of genetic mutations in parasites artificially selected for resistance to ART derivatives. These mutations encode alterations in a de-ubiquitinating enzyme (UBP-1) and in a 26S proteasome subunit (26SPS), both involved in the ubiquitin-proteasome pathway, responsible for protein turnover through selective degradation. An additional mutation was found to have occurred in a gene encoding the “mu” chain of the AP2 adaptor protein complex, a component of the endocytic machinery.

The importance of the above mentioned markers in modulating susceptibility to different drugs in the human malaria parasite remains unclear. In that context, the hypothesis to be tested in this thesis is that the three loci implicated in ART resistance in experimentally selected in *P. chabaudi* will similarly modify ART response in natural parasite populations of *P. falciparum*.

Increased artemisinin resistance in a *P. chabaudi* parasite derived from a chloroquine resistant parasite after prolonged and progressive artemisinin selection was phenotypic and genetically characterized. The whole genome sequencing identified a mutation in a gene encoding the mu chain of the AP2 adaptor protein complex. To explore the genetic variability of the ap2-mu gene in *P. falciparum* and its associations with artemisinin *in vitro* responses we sequenced field isolates from Brazil, São Tomé and Rwanda. Analysis of *P. falciparum* field isolates showed a weak association between a Ser160Asn mutation and *in vitro* dihydroartemisinin responses.

To investigate the correlation between polymorphisms in *pfubp-1* and *pfap2-mu* and *in vivo* parasite susceptibility to ART we genetically characterized samples from an ACT clinical trial carried out in Kenya. Previously work done on the same ACT clinical trial samples described sub-microscopic persistent parasites on day 3 post-treatment samples. These parasites were only detected by qPCR but the children carrying these parasites had a higher transmission potential and were far more

likely to go on to classical treatment failure at day 28 or day 42 post-treatment. The molecular work carried out here demonstrates that a Ser160Asn/Thr mutation in the *pfap2-mu* gene and an E1528D mutation in the *pfubp-1* gene might be associated with *in vivo* responses to artemisinin derivatives.

Polymorphisms on the *pfubp-1* gene and *pfap2-mu* genes were further studied using field isolates from an ACT clinical trial in Burkina-Faso which were also tested *in vitro* for their response to dihydroartemisinin and several other antimalarial drugs. Using these samples, we also investigate the genetic polymorphisms of the *pf26S-protSU*, another drug resistant candidate gene identified in the studies of *P. chabaudi*. Data revealed that polymorphisms in *pfubp1* and *pf26S-protSU*, can modulate *in vitro* responses to lumefantrine. However, this work did not reveal any significant association between polymorphisms in *pfubp-1* and *pfap2-mu* genes and *in vitro* artemisinin susceptibilities or treatment outcomes.

In order to validate the *pfap2-mu* candidate marker as an important modulator of parasite sensitivity to artemisinins and to improve understanding of the biological mechanisms of resistance to this class of drugs we further performed gene functional characterization using transfection techniques. Transgenic parasites carrying the 160Asn allele of *pfap2-mu* were significantly less sensitive to dihydroartemisinin using a standard *in vitro* test. Sensitivity to chloroquine and quinine were also reduced. Localization studies of *pfap2-mu* were performed by transfection of fluorescent-tagged gene construct into *P. falciparum* and expression of fluorescent fusion protein in parasites was observed using a confocal microscope.

The findings from this study provide the first *in vivo* evidence that polymorphisms in the *pfap2-mu* and *pfubp-1* genes modulate *P. falciparum* responses to artemisinins. Additionally, transgenic laboratory lines of *P. falciparum* carrying the 160Asn mutation in *pfap2-mu* gene have altered *in vitro* responses to dihydroartemisinin, quinine and chloroquine. We therefore propose these genes should be evaluated further as potential molecular markers of artemisinin resistance.

# Contents

<b>Abstract</b> .....	4
<b>Acknowledgements</b> .....	9
<b>Publications</b> .....	11
<b>List of Abbreviations</b> .....	13
<b>Thesis Outline</b> .....	15
<b>Chapter 1 – Introduction</b> .....	17
1.1. Malaria Burden .....	18
1.2. Plasmodium .....	19
1.3. Life cycle of <i>Plasmodium falciparum</i> .....	19
1.4. Malaria Control .....	22
1.5. Antimalarial drugs .....	24
1.6. Artemisinin-based combination therapy .....	31
1.7. Antimalarial drug resistance .....	33
1.7.1. Emergence of drug resistance .....	34
1.7.2. Definition of antimalarial drug resistance .....	35
1.7.3. Assessment and monitoring of resistance in <i>P. falciparum</i> .....	35
• <i>In vivo</i> tests .....	36
• <i>In vitro</i> tests .....	37
• Molecular markers .....	38
1.8. Modes of action and mechanisms of parasite resistance .....	39
1.9. <i>Plasmodium chabaudi</i> model system .....	54
<b>Chapter 2 - Aims</b> .....	59
<b>Chapter 3 – Materials and Methods</b> .....	61

3.1. <i>Plasmodium falciparum</i> isolates .....	62
3.2. DNA extraction .....	63
3.3. Molecular analysis of drug-resistance associated genes .....	64
3.6.1. Primer design .....	64
3.6.2. PCR .....	65
3.6.3. Sequencing of PCR products .....	66
3.6.4. Editing and assembling of sequence products .....	67
3.4. Continuous culture of <i>Plasmodium falciparum</i> .....	67
3.5. Cloning Methods .....	67
3.6.1. PCR amplification of DNA .....	67
3.6.2. Restriction/ligation cloning .....	68
3.6.3. Transformation into competent cells .....	68
3.6.4. Purification and identification of recombinant DNA .....	69
3.6. Generation of <i>P. falciparum</i> transfection constructs .....	69
3.7.1. Site-specific integration using the mycobacteriophage bxb1 integrase system .....	69
3.7.2. Construction of <i>pfap2-mu</i> -GFP fusion constructs .....	71
3.7. Transfection experiments .....	71
3.8. Isolation of genomic DNA from <i>P. falciparum</i> .....	72
3.9. Genotype analysis of transgenic parasites by PCR .....	73
3.10. Confirmation of integration by southern blot analysis .....	73
3.11. Quantitative RT-PCR on mRNA samples of <i>P. falciparum</i> .....	74
3.12. Drug susceptibility assays .....	76
3.13. Fluorescence microscopy .....	77

<b>Chapter 4 - Artemisinin resistance in rodent malaria - mutation in the AP2 adaptor <math>\mu</math>-chain suggests involvement of endocytosis and membrane protein trafficking.....</b>	<b>78</b>
<b>Chapter 5 - Directional selection at the <i>pfmdr1</i>, <i>pfprt</i>, <i>pfubp1</i> and <i>pfap2-mu</i> loci of <i>Plasmodium falciparum</i> in Kenyan children treated with ACT .....</b>	<b>123</b>
<b>Chapter 6 - <i>In vitro</i> antimalarial susceptibility of <i>Plasmodium falciparum</i> isolates from Burkina Faso and molecular markers of drug resistance .....</b>	<b>145</b>
<b>Chapter 7 - The <math>\mu</math>-subunit of <i>Plasmodium falciparum</i> clathrin associated adaptor protein 2 modulates <i>in vitro</i> parasite drug response to artemisinin, quinine &amp; chloroquine.....</b>	<b>167</b>
<b>Chapter 8 - Localization of Adaptor Protein 2 <math>\mu</math>-subunit in <i>Plasmodium falciparum</i> parasites.....</b>	<b>188</b>
<b>Chapter 9 - Discussion .....</b>	<b>204</b>
9.1. Artemisinin resistance or tolerance debate .....	205
9.2. Artemisinin resistance phenotype in rodent malaria.....	207
9.3. Correlation of <i>in vitro</i> parasite susceptibility and polymorphisms in candidate molecular markers.....	208
9.4. Correlation of <i>in vivo</i> parasite susceptibility and polymorphisms in the candidate molecular markers.....	208
9.5. Functional analysis of the <i>pfap2-mu</i> gene.....	209
9.6. SE Asia phenotype vs African phenotype.....	209
9.7. Possible model of artemisinin resistance mediated by ubiquitin-dependent endocytosis via clathrin-coated vesicles .....	211
<b>Chapter 10 - Future perspectives .....</b>	<b>215</b>
<b>Chapter 11 - References .....</b>	<b>218</b>



# ACKNOWLEDGEMENTS

A PhD is a long and challenging journey but thankfully it is far from a lonely one. This work would not have been possible without the help and support of many people, whom I would like to thank here.

I am grateful to my supervisors who have provided support at each and every step of my work. I would like to thank Dr Pedro Cravo for introducing me to the world of malaria and inspiring me to continue working toward a PhD after completing my Master's degree. I thank Dr Rachel Hallett for taking me as her PhD student, the work in this thesis could not have been completed without her invaluable support and encouragement. I would also like to thank Dr Colin Sutherland for his support, enthusiasm and expertise. I am grateful and feel very fortunate to have had a chance to work with and learn from him.

I gratefully thank my Advisory Committee; I am thankful to Professor David Warhurst for all his insightful comments and seemingly endless knowledge, and to Dr Martin Taylor for his time and expertise in guiding my research.

I would like to thank Pedro, Paul, Axel, Sofia and Louise, it was great to be part of the "*chabaudi* team".

Thanks to David Baker and everyone in his lab for their guidance and help. I especially want to thank Christian Flueck for offering so much help with my project and never getting tired of answering my questions, most of the time, with more questions. I appreciate the support from David Fidock and his team.

I also want to thank all the Sutherland and Hallett lab members. My special acknowledgment is for Khalid. I really appreciate his generous help and suggestions; he has been an excellent colleague and a good friend. Brighid, Sumi, Bekah, Don and Inke, thank you for sharing with me the ups and downs of the research life, for always encouraging me, and for all your help and friendship.

I am deeply thankful for the encouragement and companionship that I have received from my friends and colleagues at the LSHTM during the last four years. Khalid, Nuno, Vanessa, Bekah, Inke, Paul and Sadia: thank you for the long lunch and coffee breaks (during sunny, rainy, snowy or cloudy days), for all the delicious dinners, all the endless conversations about everything and nothing. Thank you for all your help and support during the rough times but most importantly for being my friends.

To my family, for their support and love they have given me over the many years. My final thanks go to Plim, for all his love and endless support. For being my sunshine and for “making me happy when skies are grey”.

## PUBLICATIONS

**Henriques G**, Martinelli A, Rodrigues L, Modrzynska K, Fawcett R, Houston DR, Borges ST, d'Alessandro U, Tinto H, Karema C, Hunt P, Cravo P. (2013) "Artemisinin resistance in rodent malaria - mutation in the AP2 adaptor mu-chain suggests involvement of endocytosis and membrane protein trafficking." *Malar J* 12: 118 (**Chapter 4**)

**Henriques G**, Hallett RL, Beshir KB, Gadalla NB, Johnson RE, Burrow R, van Schalkwyk DA, Sawa P, Omar SA, Clark TG, Bousema T, Sutherland CJ. (2014) "Directional selection at the *pfmdr1*, *pfcr1*, *pfubp1* and *pfap2-mu* loci of *Plasmodium falciparum* in Kenyan children treated with ACT". *J Infect Dis.* jiu358 first published online July 3, 2014 doi:10.1093/infdis/jiu358 (**Chapter 5**)

**Henriques G**, van Schalkwyk DA, Burrow R, Warhurst DC, Thompson E, Baker DA, Fidock DA, Hallett R, Flueck C, Sutherland CJ. "The mu-subunit of *Plasmodium falciparum* clathrin-associated adaptor protein 2 modulates *in vitro* parasite drug response to artemisinin and quinine" *Antimicrob. Agents and Chemother.* first published online 17 February, 2015, doi: 10.1128/AAC.04067-1 (**Chapter 7**)

### Publications not included in this thesis:

van Schalkwyk DA, Burrow R, **Henriques G**, Gadalla NB, Beshir KB, Hasford C, Wright SG, Ding XC, Chiodini PL, Sutherland CJ. (2013) "Culture-adapted *Plasmodium falciparum* isolates from UK travellers: *in vitro* drug sensitivity, clonality and drug resistance markers." *Malar J* 12, 320

Rodrigues L, **Henriques G**, Cravo P. (2013) "MDR1-associated resistance to artesunate + mefloquine does not impair blood-stage parasite fitness in a rodent malaria model." *Infect Genet Evol.* 14:340-6

Martinelli A, **Henriques G**, Cravo P, Hunt P. (2011) "Whole genome re-sequencing identifies a mutation in an ABC transporter (*mdr2*) in a *Plasmodium chabaudi* clone with altered susceptibility to antifolate drugs. *Int J Parasitol.* 41(2):165-71.

Rodrigues LA, **Henriques G**, Borges ST, Hunt P, Sanchez C, Martinelli A, Cravo P. (2010) "Experimental evolution of resistance to Artemisinin Combination Therapy results in amplification of the *mdr1* gene in a rodent malaria parasite." *PLoS One* 5:e11593

de Almeida A, do Rosário VE, **Henriques G**, Arez AP, Cravo P. (2010) "*Plasmodium vivax* in the Democratic Republic of East Timor: parasite prevalence and antifolate resistance-associated mutations." *Acta Tropica* 115:288-292

Silva M, **Henriques G**, Sánchez C, Marques PX, Suarez CE, Oliva A. (2009) "First survey for *Babesia bovis* and *Babesia bigemina* infection in cattle from Central and Southern regions of Portugal using serological and DNA detection methods." *Vet Parasitol.* 166:66-72

Criado-Fornelio A, Buling A, Asenzo G, Benitez D, Florin-Christensen M, Gonzalez-Oliva A, **Henriques G**, Silva M, Alongi A, Agnone A, Torina A, Madruga CR. (2009) "Development of fluorogenic probe-based PCR assays for the detection and quantification of bovine piroplasmids." *Vet Parasitol.* 162:200-206

## LIST OF ABBREVIATIONS

<b>ACT</b>	Artemisinin-based Combination Therapy
<b>AL</b>	Artemether-Lumefantrine
<b>AP</b>	Adaptor Proteins
<b>ART</b>	Artemisinin
<b>AS - AQ</b>	Artesunate-Amodiaquine
<b>bp</b>	base pairs
<b>cDNA</b>	Complementary Deoxyribonucleic Acid
<b>CQ</b>	Chloroquine diphosphate
<b>DHA</b>	Dihydroartemisinin
<b>DHA-PIP</b>	Dihydroartemisinin-Piperaquine
<b>DNTP's</b>	Deoxynucleotides
<b>DNA</b>	Deoxyribonucleic Acid
<b>DV</b>	Digestive vacuole
<b>ELISA</b>	Enzyme-Linked Immunosorbent Assay
<b>Exo I</b>	Exonuclease I
<b>G6PD</b>	Glucose-6-Phosphate Dehydrogenase
<b>IC<sub>50</sub></b>	50% Inhibitory Concentration
<b>Indel</b>	Insertion/Deletion
<b>IPT</b>	Intermittent Preventive Treatment
<b>IRS</b>	Indoor Residual Spraying
<b>ITN</b>	Insecticide Treated Net
<b>LGS</b>	Linkage Group Selection
<b>LLINs</b>	Long Lasting Insecticide Treated Nets
<b>LUM</b>	Lumefantrine
<b>MDA</b>	Monodesethylamodiaquine
<b>OR</b>	Odds ratio
<b>PBS</b>	Phosphate-Buffered Saline
<b>Pgh1</b>	P-glycoprotein Homologue 1
<b>PIP</b>	Piperaquine
<b><i>pc26S-prot-SU</i></b>	<i>P. chabaudi</i> 26S proteasome regulatory subunit gene
<b><i>pcap2-mu</i></b>	<i>P. chabaudi</i> mu chain of the AP2 adaptor protein gene
<b><i>pcubp1</i></b>	<i>P. chabaudi</i> de-ubiquitinating enzyme gene

<b>PCR</b>	Polymerase Chain Reaction
<i>pf26S-protSU</i>	<i>P. falciparum</i> 26S proteasome regulatory subunit gene
<i>Pfap2-mu</i>	<i>P. falciparum</i> mu chain of the AP2 adaptor protein complex gene
<b>PfATPase6</b>	Sarco/endoplasmic reticulum Ca <sup>2+</sup> - ATPase orthologue of <i>P. falciparum</i>
<i>pfATPase6</i>	<i>Sarco/endoplasmic reticulum Ca<sup>2+</sup> - ATPase orthologue of P. falciparum</i> gene
<b>PfCRT</b>	<i>P. falciparum</i> chloroquine resistance transporter
<i>Pfdhfr</i>	<i>P. falciparum</i> dihydrofolate reductase gene
<i>Pfdhps</i>	<i>P. falciparum</i> dihydropteroate synthase gene
<i>Pfk13</i>	<i>P. falciparum</i> kelch 13 gene
<i>pfmdr1</i>	<i>P. falciparum</i> multidrug resistance protein 1 gene
<i>pfmrp1</i>	<i>Plasmodium falciparum</i> multidrug resistance-associated 1 gene
<i>Pfnhe1</i>	<i>P. falciparum</i> sodium/hydrogen exchanger gene
<i>pfubp1</i>	<i>P. falciparum</i> de-ubiquitinating enzyme gene
<b>PPR<sub>48</sub></b>	Parasite reduction ratio at 48 hours
<b>qPCR</b>	Quantitative PCR
<b>QN</b>	Quinine
<b>SD</b>	Standard Deviation
<b>SNP</b>	Single Nucleotide Polymorphism
<b>SMC</b>	Seasonal Malaria Chemoprevention
<b>SP</b>	Sulfadoxine-pyrimethamine
<b>WHO</b>	World Health Organization
<b>WT</b>	Wild-type

# THESIS OUTLINE

This PhD thesis is compiled in the “research paper style” format, as approved by the London School of Hygiene and Tropical Medicine. Therefore, the main body of the thesis will be presented as various manuscripts that have already been published in an international peer-review journal, are currently in submission or have been prepared for publication.

The Introduction chapter (**Chapter 1**) provides a review of the relevant literature background, in a more comprehensive approach than that presented in the various manuscripts. The aim and the specific objectives of the thesis are stated on **Chapter 2** and a detailed description of the materials and methods used in the thesis is given in **Chapter 3**. **Chapters 4, 5, 6, 7** and **8** contain the key findings of the thesis in the form of research papers that are already published or will be submitted.

This thesis focus on two fulcral issues in antimalarial drug resistance:

---

## Section 1

Polymorphisms in the genes of interest in parasites treated *in vivo*

\*

In **Chapter 4** we have identified a unique mutation in a gene encoding the  $\mu$ -chain of the AP2-adaptor complex in a *Plasmodium chabaudi* parasite that presents a high level of artemisinin resistance. Allelic variations of the *Plasmodium falciparum* orthologue gene were investigated in field samples from Africa and South America. The association between the allelic variations and the *in vitro* responses to artemisinin derivatives were also evaluated in these samples (data not included in the published manuscript).

**Chapter 5** reports the genotype of the recently described sub-microscopic parasites that persist after artemisinin combination treatment, in Kenyan children. In this chapter, the DNA sequences of resistance associated parasite loci (*pfcr1*, *pfmdr1*, *pfubp-1* and *pfap2-mu*) were determined in pre- and post-treatment isolates.

**Chapter 6** describes the genotype of the three candidate markers studied on this thesis (*pfubp-1*, *pfap2-mu* and *pf26S-protSU*), using field isolates from an Artemisinin

Combination Therapy trial conducted in Burkina Faso. The correlation between the polymorphisms found and the *in vitro* responses profiles to artemisinin derivatives and other antimalarial drugs was also assessed.

---

## Section 2

Functional analysis of the *pfap2-mu* gene *in vitro*

\*

**Chapter 7** describes the generation of two transgenic parasites lines carrying an extra copy of either the wild-type (WT) copy of *pfap2-mu* or the 160Asn form, in addition to their endogenous WT *pfap2-mu* gene. The *in vitro* susceptibility of these parasites to several antimalarial drugs was evaluated.

The generation of a transgenic parasite stably expressing GFP-fused *pfap2-mu* and subsequent cellular localization of the GFP-fused protein is reported on **Chapter 8**.

**Chapter 9** summarizes and discusses the study as a whole, incorporating all five manuscripts, as well as the data presented in the additional unpublished section. The final chapter (**Chapter 10**) focus on the future perspectives in relation to the main findings of this thesis.

The references for the manuscripts are provided for each paper, whereas the references for the Introduction, Materials and Methods and Discussion chapters are presented at the end of the thesis.



# Chapter 1

---

**INTRODUCTION**

# Chapter 1 – Introduction

## 1.1.MALARIA BURDEN

Despite considerable scientific advances and the development of modern drugs, malaria remains a major public health concern. Globally around 3.4 billion people live in areas at risk of malaria, resulting in 207 million clinical cases in 2012. Although it is disseminated throughout more than 100 countries, the bulk of this burden falls on sub-Saharan Africa with approximately 80% of all malaria cases and 90% of related deaths in young children (WHO 2013f)(Figure 1.1).

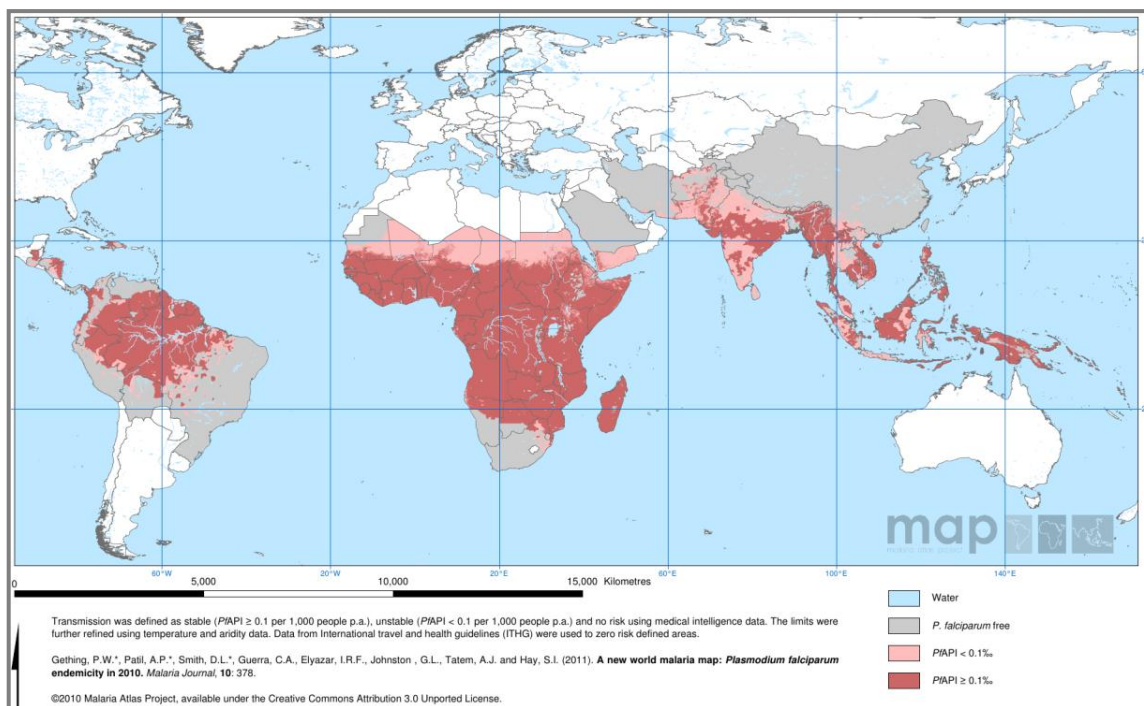

**Figure 1.1** The spatial distribution of *Plasmodium falciparum* malaria transmission in 2010 (adapted from Gething et al., 2011 (Gething et al. 2011). Areas of no risk, with unstable risk (PfAPI  $< 0.1\%$ ) and with stable risk (PfAPI  $\geq 0.1\%$ ) are shown.

The number of deaths due to malaria decreased substantially between 2000 and 2012, more than 45% globally and by 49% in African countries, resulting in an estimated 3.3 million malaria deaths prevented over this period (WHO 2013f). Nevertheless, the effect of malaria extends far beyond this direct measure of mortality since morbidity in endemic countries leads to major socio-economic losses. Acute febrile illness, anaemia, chronic debilitation, complications in the course and outcome of pregnancy, school and

employment absences and delays in cognitive and physical development contribute to a heavy public-health burden, which has a negative impact on the social and economic development of affected countries (Sachs and Malaney 2002; Bloland 2003; Chima *et al.* 2003; Breman *et al.* 2004; Malaney *et al.* 2004; Barnes and White 2005; Okorosobo *et al.* 2011). The disease contributes to an approximately 1.3% annual reduction in economic growth in countries with high levels of transmission (WHO 2011b).

## 1.2. PLASMODIUM

Malaria is caused by protozoan parasites of the genus *Plasmodium*, which are inoculated into humans by biting female *Anopheles* mosquitoes. The genus contains more than 100 species of which six are found in natural infections in humans: *Plasmodium falciparum*, *Plasmodium vivax*, *Plasmodium malariae*, *Plasmodium ovale curtisi*, *P. ovale wallikeri* and, in parts of South-East Asia, the simian malaria parasite *Plasmodium knowlesi* (Singh *et al.* 2004; Cox-Singh *et al.* 2008; Sutherland *et al.* 2010; WHO 2013c).

These species differ morphologically, immunologically, in their geographical distribution, in their ability to relapse and in their response to drugs. By far, the most virulent species is *P. falciparum*, which causes the majority of severe malaria morbidity and mortality (Greenwood *et al.* 2005)

## 1.3. LIFE CYCLE OF *PLASMODIUM FALCIPARUM*

The *P. falciparum* life cycle comprises numerous transition stages and occurs between two separate hosts (definitive and intermediate) (Figure 1.2). The cycle begins when haploid **sporozoites** are injected into the intermediate human host by an infected female mosquito of the genus *Anopheles* during a blood meal. These motile forms of the parasite rapidly access the blood stream and then migrate to the liver. There, each sporozoite traverses a few hepatocytes, before finally establishing in one of them. The sporozoite, differentiates and undergoes asexual multiplication resulting in tens of thousands of **merozoites**, which burst from the **hepatocyte (hepatic stage)**. One *P. falciparum* sporozoite develops into approximately 40,000 merozoites in a liver cell over 6 days. Upon release

from the liver, individual merozoites invade red blood cells (erythrocytes). Once inside the erythrocyte and during a 48h cycle (**erythrocytic stage**), *P. falciparum* develops into a **ring stage/early trophozoite** and then into a highly metabolically active late stage **trophozoite**. Finally, trophozoites develop into **schizonts** and asexual replication occurs. In the latter, new **merozoites** (8-32 daughter cells) are formed within the schizont and are released to the bloodstream when the erythrocyte bursts. The clinical manifestations of malaria (such as a spiking fever) are associated with the synchronous rupture of infected erythrocytes. The free merozoites immediately invade new erythrocytes. Although the majority of invading merozoites will go on to develop into schizonts and continue the asexual cycle, a small proportion enter the sexual phase of the life cycle by differentiating into haploid male or female **gametocytes**. These are the only forms that are transmissible to the mosquito.

For transmission to occur, when an infectious host is bitten by a female anopheline mosquito, both male and female gametocytes must be taken up during the blood meal. Inside the mosquito midgut, gametocytes develop into gametes and sexual reproduction takes place, whereby 8 flagellated **microgametes** are released from a male gametocyte. These fertilize the female **macrogamete** to form a diploid zygote that converts into an motile **ookinete**. After penetrating a cell wall in the midgut epithelium, the ookinete subsequently develops into an **oocyst**. Each oocyst produces haploid sporozoites by asexual reproduction. The oocyst finally ruptures to release a large number of **sporozoites** into the haemolymph of the mosquito, from where they travel to the salivary glands. The sporozoites remain here, ready to be inoculated into the next host and begin a new cycle of infection when the female mosquito takes a further blood meal (Figure 1.2).

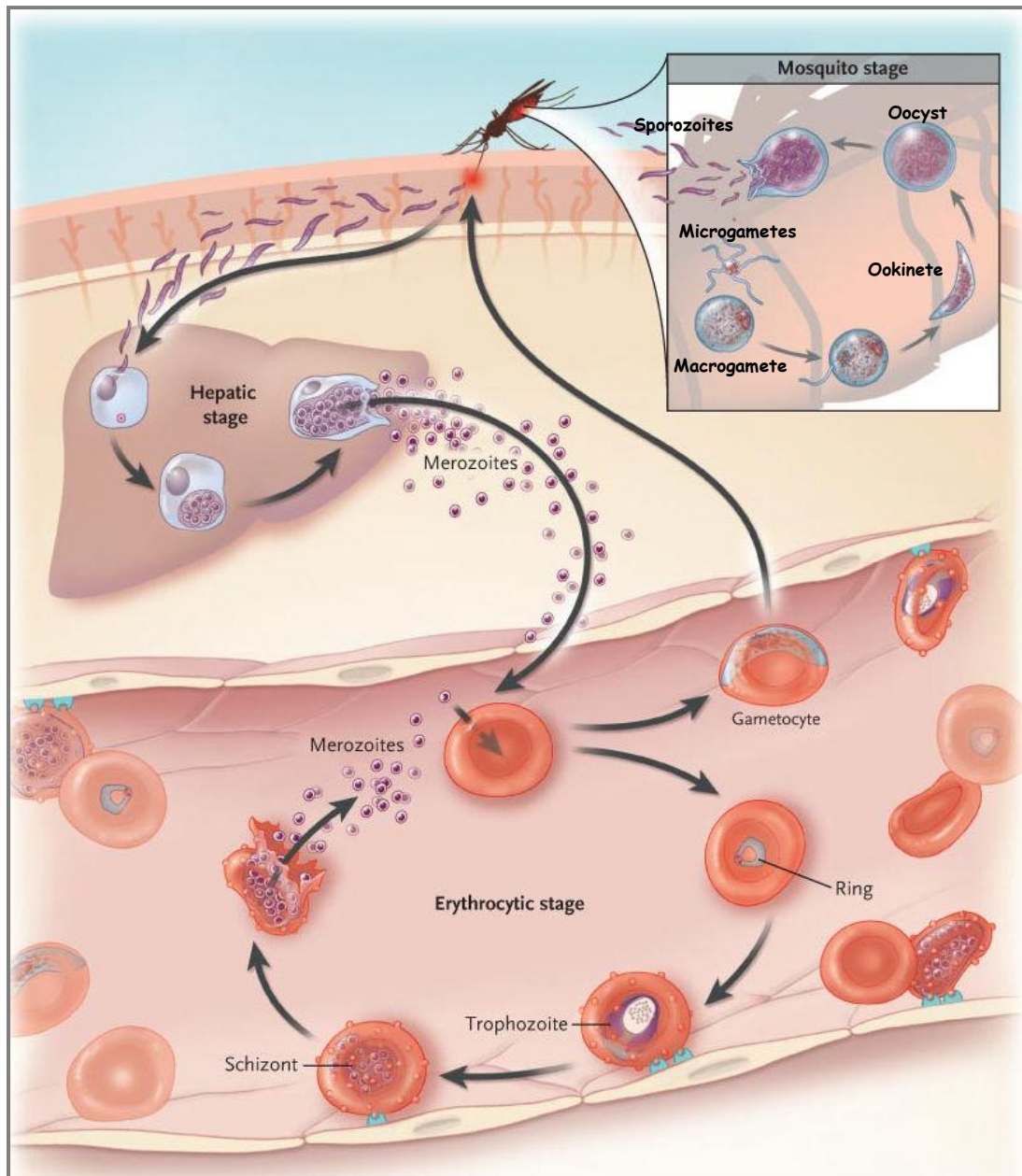

**Figure 1.2.** The life cycle of *P. falciparum*, the most virulent human malaria parasite (adapted from (Rosenthal 2008)). The malaria parasite uses both an anopheline mosquito and a human host. Sexual reproduction occurs in the mosquito and asexual reproduction takes place in the human.

## 1.4. MALARIA CONTROL

Political commitment and important increase in international funding has led to remarkable improvements in malaria control in the past decade, resulting in major reductions in the burden of malaria caused by *P. falciparum*. Globally, the estimated incidence of malaria has been reduced by 29% and the mortality rates have declined by 45 % (WHO 2013f). These reductions are partly due to improved vector control, diagnostic testing and better access to artemisinin combination treatment (O'Meara *et al.* 2010; WHO 2012b).

Three living entities are involved in the malarial infection; parasite, host and vector. In order to reduce the burden of malaria, interventions can be designed to target several stages of the parasite lifecycle. For example, the parasite can be targeted in the host either directly with drugs, or indirectly with vaccines. Similarly, strategies that reduce vector contact with the host or increase vector mortality can be employed to reduce the number of new infections (Greenwood 2008).

- Vector control

There are two key approaches to malaria prevention by vector control: the use of long lasting insecticide –treated nets (LLINs) and indoor residual spraying (IRS). LLINs are factory pyrethroid insecticide treated mosquito nets, which do not require any re-treatment during their expected lifespan (generally 2–3 years). These nets have a high degree of protection for the individual sleeping under the net and have an effect at the community level as well, by killing the mosquitoes that contact the net (WHO 2007). IRS is a method used to kill mosquitoes by spraying of a long-lasting residual insecticide on to potential malaria vector resting surfaces (internal walls and ceilings). IRS repels the mosquitoes from entering the houses and kills the female mosquitoes that rest inside them, having a large effect on reducing transmission at community level (WHO 2013b).

These central interventions may be complemented by other methods such as larval control or environmental management, which aims to reduce mosquito breeding sites (WHO 2006; 2008).

- Vaccines

Despite decades of intensive research, there is no licensed malaria vaccine to date (Girard *et al.* 2007; Matuschewski and Mueller 2007; Hill 2011), however a recent phase III clinical trial with the RTS,S vaccine showed promising results, with 55% reduction in the incidence of clinical malaria among young children and 33% among infants. The efficacy against severe malaria was 47% among young children and 37% against infants (Agnandji *et al.* 2011; Agnandji *et al.* 2012). The full trial results will be available at the end of 2014 and a World Health Organization (WHO) recommendation for use may occur in 2015 (WHO 2013c). The available data suggest that this vaccine is likely to be implemented as an addition to, not a replacement for, existing preventive, diagnostic and treatment measures.

Measures aimed against the parasite still need to be based on the use of drugs either as treatment or as prophylaxis. Medication reduces morbidity and mortality by terminating a malaria infection in a patient and restricts malaria transmission by diminishing the parasite reservoir (WHO 2013c). Antimalarial drugs are also used as a preventive measure, as chemoprophylaxis for travellers to malaria endemic areas, for intermittent preventive treatment (IPT) in areas of high transmission in specific high-risk groups such as pregnant women and infants and for seasonal malaria chemoprevention in children in the Sahel sub-Region of Africa (WHO 2013d).

## 1.5. ANTIMALARIAL DRUGS

This section will give an introduction to the most historically important antimalarial drugs with a focus on those used as partner drugs in artemisinin combination therapy. The chemical structures of these antimalarial drugs are summarized in Figure 1.3.

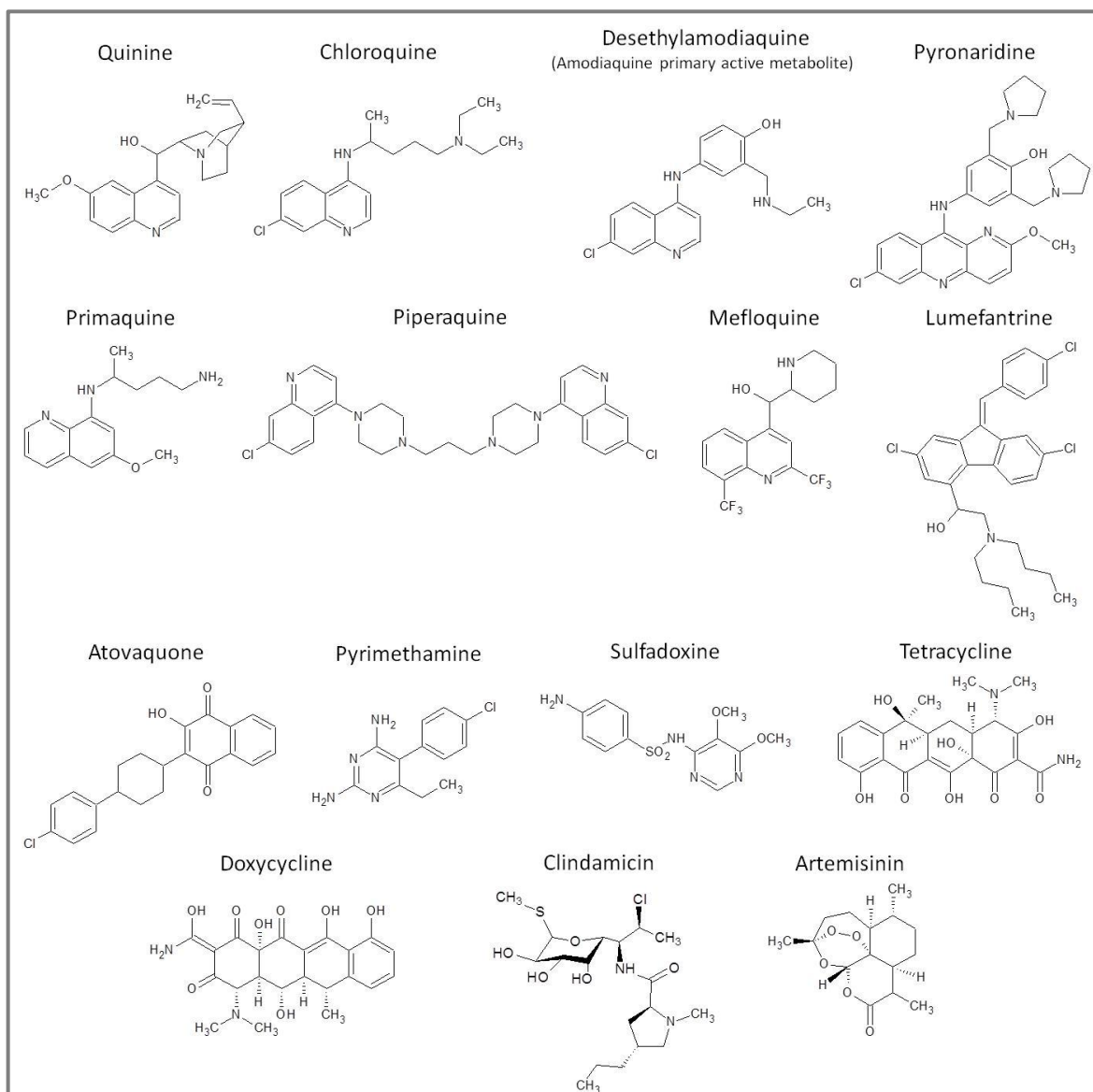

**Figure 1.3.** Chemical structures of commonly used antimalarial drugs with a focus on those used as partner drugs in artemisinin combination therapy.



- Quinolines and related compounds

### Quinine

Western medicine has relied on the medical properties of quinine (QN) and related alkaloids since the early 17th century (WHO 1986; Meshnick and Dobson 2001). QN is the most abundant alkaloid in the bark of the cinchona tree (originally found in South America) and was first isolated in 1820, by the French chemists Pierre Pelletier and Joseph Caventou (Siegel and Poynter 1962; Greenwood 1992; Foley and Tilley 1998; Meshnick and Dobson 2001).

QN has rapid schizonticidal action against intra-erythrocytic malaria parasites and its half-life ranges between 11-18 hours (White *et al.* 1983; Jamaludin *et al.* 1988). QN has long been the basis for treatment of severe malaria although following the results of the SEAQUAMAT and AQUAMAT trials (Dondorp *et al.* 2005; Dondorp *et al.* 2010), WHO approved the replacement of QN with artesunate as treatment of choice for severe malaria, with QN still recommended where artesunate is not available (WHO 2010b).

The need to treat soldiers for malaria infection during the World War I promoted the chemical research on antimalarial discovery and the attempt to synthesize quinine led to the development of methylene blue and the dye industry. The first synthetic drug was the 8-aminoquinoline pamaquine (also called plasmoquine). Pamaquine was synthesized in 1920 by German scientists and has anti-relapse activity (kills hypnozoites, the persistent liver stage parasites of *P. vivax* and *P. ovale*) but was later found to be too toxic and not used for long (Greenwood 1995; Sa *et al.* 2011).

### Chloroquine and Amodiaquine

In 1934, Andersag in the German programme developed a 4-aminoquinoline compound named resoquin (resoquine), but the drug was ignored for a decade due to toxicity concerns. During World War II, the interest in resoquine was renewed, when sontoquine the slightly modified compound, was captured from the Germans in North Africa. Resoquine was renamed as chloroquine (CQ) and was introduced in 1946 (Loeb 1946). CQ is considered to be one of the most successful drugs ever produced. CQ was efficacious against all blood stage malaria parasites, well tolerated, easily administered, inexpensive

and therefore the most widely used antimalarial drug (WHO 1986; Meshnick and Dobson 2001; Sa *et al.* 2011) until the 1990s when parasite resistance led to its replacement with other regimens (White 1998a). CQ combined with primaquine is still recommended for treatment of *P. vivax* infections, because resistance has not fully developed (Price *et al.* 2009; WHO 2010b).

CQ was one of many antimalarials resulting from scientific advances made during World War II. A massive antimalarial screening programme coordinated by American scientists led to the discovery of amodiaquine, another 4-aminoquinoline (Greenwood 1995; Meshnick and Dobson 2001). However, in the 1980s its use was discouraged due to serious problems of hepatotoxicity after long term prophylaxis (Taylor and White 2004). After the development of CQ resistance in the 1990s, the use of amodiaquine was reviewed and nowadays is commonly used in combination with artesunate as first-line treatment. It is assumed that the serious toxic effects do not occur in shorter therapeutic treatments (Olliaro *et al.* 1996).

### **Pyronaridine**

Pyronaridine is structurally related to chloroquine and was synthesized in the Chinese Institute of Parasitic Diseases in 1970 (Zheng *et al.* 1979; Zheng *et al.* 1982). It has potent *in vitro* activity against erythrocytic stages of *P. falciparum* (Ringwald *et al.* 1996; Vivas *et al.* 2008) and it has been used in China for treatment of malaria for more than 30 years (Croft *et al.* 2012). Clinical studies have demonstrated that pyronaridine is safer and less toxic than chloroquine (Chang *et al.* 1992). Additionally, pyronaridine is reported to be highly effective in cases of chloroquine resistance (Ringwald *et al.* 1996) and has been recently combined with artesunate as a new combination therapy (Croft *et al.* 2012; Kayentao *et al.* 2012; Rueangweerayut *et al.* 2012).

### **Primaquine**

Attempts to search for alternative drugs with characteristics similar to pamaquine, in particular, the ability to prevent relapse led to the discovery of primaquine. Primaquine became available during the Korean War and remains in use today (Greenwood 1995; Baird and Hoffman 2004). Primaquine is used in the treatment of *Plasmodium vivax* and *Plasmodium ovale* hypnozoites and for malaria prophylaxis in endemic regions (Hill *et al.*

2006; Vale *et al.* 2009). However, primaquine causes haemolysis in patients who have a deficiency in the glucose-6-phosphate dehydrogenase (G6PD) enzyme, a common deficiency in malaria endemic regions of the world (Howes *et al.* 2013).

Primaquine is also currently the only fully effective gametocytocidal drug and recently the WHO recommended a single low-dose of primaquine (0.25 mg base/kg, dose that is unlikely to cause serious toxicity problems in G6PD deficient patients) for patients with uncomplicated *P. falciparum* malaria, in addition to an artemisinin based combination therapy (WHO 2012a).

### **Piperaquine**

In the face of increasing drug resistant malaria infections, other quinoline based compounds have been synthesized and studied. Piperaquine was first synthesized in the 1960s in France and developed in China, where it was used for prophylaxis and treatment for the next 20 years (O'Neill *et al.* 2012a). Piperaquine includes two 4-aminoquinoline moieties and has shown high effectiveness against CQ resistant *P. falciparum*, is well tolerated, relatively inexpensive, has a long elimination half-life, and is thus considered a good partner drug in combination therapy. Thus dihydroartemisinin-piperaquine is recommended for artemisinin combination therapy by WHO (Davis *et al.* 2005; WHO 2010b).

### **Mefloquine**

The U.S. Army Antimalarial Drug Development Program, initiated during the Vietnam War, was responsible for the discovery of new chemical groups that later served as prototypes for the development of other antimalarials compounds (Kitchen *et al.* 2006). One such compound is mefloquine, like quinine a 4-quinolinemethanol, which was introduced in the mid-1970s (WHO 1986; Shanks 1994). Mefloquine was approved for use in 1989 and is still currently prescribed as prophylaxis, due to a long half-life that requires only a once-weekly dosing, and in combination with artesunate as first line treatment (WHO 2010b; Biamonte *et al.* 2013). However, emergence of resistance and fears about neurotoxicity are limiting its use, in favor of safer and better tolerated antimalarial drugs (Overbosch *et al.* 2001; Croft 2007).

### **Lumefantrine**

Lumefantrine (originally called benflumetol) was synthesized in the 1970s by the Beijing Academy of Military Medical Sciences (Basco, Bickii, *et al.* 1998). Studies on the combination of artemether and lumefantrine were also performed at the same Academy and the results indicated high efficacy and synergistic activity of the two antimalarial drugs (Hassan *et al.* 1999). The artemether-lumefantrine(AL) combination was the first fixed-dose artemisinin-based combination therapy recommended and pre-qualified by WHO for the treatment of *P. falciparum* uncomplicated malaria (Nosten and White 2007). Lumefantrine, has never been used as monotherapy prior to its combination with artemether, so the risk of resistance to this compound may be lower when compared with other partner drugs used in artemisinin based therapies (Premji 2009).

### **Atovaquone**

Another chemical group developed were the 2-hydroxynaphthoquinones, which provided the basis for the discovery of atovaquone (WHO 1986; Meshnick and Dobson 2001). Atovaquone is now being used in combination with proguanil (Malarone) for treating patients with uncomplicated malaria or employed as prophylaxis in travelers due to its ability to clear liver schizonts (Hudson 1993; Biamonte *et al.* 2013).

- **Antifolates**

Antifolate drugs were first developed as antibacterial agents but a number were also found to have activity against malaria parasites (Curd *et al.* 1945). During the II World War British chemists synthesized a group of compounds, derivatives of pyrimidine, designated as antifolates, which target the folate metabolism (WHO 1986; Schlitzer 2007). Proguanil is one of these compounds. The discovery of proguanil encouraged further investigation on antifolates in the early 1950s (WHO 1986; Nzila 2006) and in 1951 Falco and colleagues found that pyrimethamine was active against blood forms of malaria (Falco *et al.* 1951). Other antifolates include the sulfa drugs; the most important are the sulphonamide, sulfadoxine and the sulfone, dapsone. Although these drugs have antimalarial activity when

used alone, when used in combination they exhibit a synergistic effect. A combination of two antifolate compounds, pyrimethamine and sulfadoxine (Fansidar™) was one of the first combination therapies in malaria treatment and became available in 1971 (Shanks *et al.* 1989). Sulfadoxine-pyrimethamine (SP) is effective, cheap and is considered a drug with good compliance, tolerance and safety and has the advantage of a single-dose therapy with a long half-life (Basco, Tahar, *et al.* 1998). After its introduction as a new antimalarial drug SP replaced CQ in many countries, due to the emergence and spread of CQ resistance (White 2004).

Resistance to SP emerged rapidly in the Amazon Basin of South America (WHO 2001c; Gregson and Plowe 2005) and most areas of South East Asia and forced countries to change to more effective artemisinin combination therapies (ACTs) (WHO 2001c). SP plus artesunate is currently recommended as first line treatment for uncomplicated *P. falciparum* malaria (WHO 2010b) and SP alone continues to be widely used for treatment where ACT is not available (Thriemer *et al.* 2006; Mkulama *et al.* 2008). Furthermore, due to its safety and good tolerance SP is still used for malaria prevention during pregnancy and in children in IPT programmes in African areas with moderate-to-high malaria transmission and low drug resistance (WHO 2001d; Peters *et al.* 2007; WHO 2013e). It is also used in combination with amodiaquine as seasonal malaria chemoprevention (SMC) in children to reduce morbidity and mortality of malaria in Sahel sub-Region of Africa (WHO 2013d). SMC is not recommended elsewhere, due to known high levels of resistance to amodiaquine and SP in eastern and southern Africa.

- Antibiotics

Animal studies in the late 1940s demonstrated that some antibiotics possess antimalarial properties. Interestingly, when treated with antibiotics the parasites in the initially exposed host cells are not damaged. However, after these daughter cells invade a new host cell, division is slowed and no further progeny are produced (Goodman and McFadden 2013). This phenotype is known as “delayed death” and it is the cause for the longer parasite clearance times and prolonged symptoms. Therefore, most antibiotics should be combined with a more rapidly acting drug to treat malaria, such as artemisinin or quinine (Dahl and Rosenthal 2008) or used in monotherapy as antimalarial prophylaxis in travellers.

WHO recommends the use of tetracycline or doxycycline or clindamycin in combination with artesunate or QN as second line treatment of *falciparum* malaria (WHO 2010b) and doxycycline alone is recommended for prophylaxis in many malaria endemic areas (Tan *et al.* 2011). Azithromycin is also a slow acting antimalarial but in combination with CQ was shown to be synergistic against CQ resistant strains and both drugs have demonstrated safety in children and pregnant woman and can be used in intermittent preventive treatments (Chico *et al.* 2008).

- Artemisinin compounds

The therapeutic benefits of the qinghao plant (*Artemisia annua*) were documented in China two thousand years before the isolation of active component, artemisinin (Peters 1987; Hsu 2006; Cui and Su 2009). In the 1970s the sesquiterpene lactone artemisinin was isolated and characterized by Chinese scientists in search of new antimalarial drugs against CQ resistant malaria (Meshnick and Dobson 2001; White 2008).

Artemisinin (ART) chemical modifications carried out by the original Chinese developers improved solubility and absorption, resulting in the water soluble derivative artesunate and the more active oil-soluble dihydroartemisinin (DHA) and artemether (Cui and Su 2009). ART and its derivatives are currently the most important class of antimalarial drugs, presenting many advantages over other compounds. These advantages include several possible routes of administration, suitability for treating severe malaria, thus replacing QN and avoiding its side effects (Dondorp *et al.* 2010). This class of compounds possesses several important pharmacological characteristics. Firstly, ART can reduce the number of parasites faster than any other class of antimalarial drug and thus provide rapid clinical relief (Hien and White 1993; White 1997). Additionally, ARTs are active against early ring forms as well as the usual targets of chloroquine and quinine, trophozoites, blood schizonts, early gametocytes and later ring forms (Krishna *et al.* 2004a). This latter property may help diminish transmission rates at a population level (Price *et al.* 1996) since attacking early ring forms, can impair gametocyte development. Altogether, ART derivatives when used appropriately can, reduce the incidence of malaria and reduce drug use, and thus may contribute to slowing the evolution of drug resistance (Price *et al.* 1996; White 1999).

The use of ART as monotherapy over short periods (less than 5 days) is associated with high treatment failure rates (recrudescence) because of the short plasma half-lives of these

drugs (Giao *et al.* 2001). Clearance of parasitaemia is only temporary in up to 50% of patients (WHO 1998). Higher efficacy can be obtained with prolonged regimens however, 7 days of ART monotherapy still only cures 80-90% of uncomplicated falciparum infections (Woodrow *et al.* 2005). For this reason, and to avoid resistance development, ART is only used in combination therapy, as will be further discussed.

## 1.6. ARTEMISININ-BASED COMBINATION THERAPY

To optimize ACT treatment, the combination of an ART derivative with another structurally unrelated antimalarial, has been proposed as the best therapeutic strategy (WHO 2010b) in order to improve treatment efficacy and slow down the development of resistance to the individual drugs in the combination (WHO 2001a). The concept that combination treatment, using drugs with different targets, decreases the chance of a natural resistant strain to emerge was first developed in the treatment of tuberculosis and has been adopted widely for the treatment of the human immunodeficiency virus (HIV) and cancer (White 1999). The underlying principle for the impact of combination therapy on drug resistance is based on the assumption that drug resistance essentially depends on DNA mutation. Provided that the constituent drugs administered in the combination have independent modes of action, the probability of a parasite developing resistance to both drugs simultaneously is significantly reduced compared to developing resistance to one drug (White *et al.* 1999).

ART and its derivatives are highly potent and rapid acting, with a parasite reduction rate of 10 000 parasites per erythrocytic cycle (48h) (White 1997). However these compounds have extremely short half-lives (Table 1.1), the active metabolite of the ART compounds, DHA, is eliminated with a half-life of ~1 h (White 2008). For this reason, the administration of ARTs with longer-acting agents is required (Nyunt and Plowe 2007). In an ACT, the ART derivative kills most of the parasites rapidly and those that remain are eliminated by a high concentration of the longer-lasting partner drug (Table 1.1), after the short-lived ART has dropped below therapeutic levels (White 2008). In this way the ART derivative should protect its partner drug. If the treatment is successful, the partner drug also protects the ART derivative by removing all the remaining parasites that were initially exposed to the ART. Consequently the probability that mutant parasites survive and emerge after treatment with these two drugs is lower (White 1997; Nosten and White 2007). However, it

is now accepted that a mismatch in elimination half-lives may not be as advantageous as previously assumed (Peters 1985; Hastings and Watkins 2006). The underlying reason is that, after the rapid elimination of the ART derivative from the organism, the long-lasting drug remains in the blood stream in sub-therapeutic levels, strongly selecting for the evolution of tolerance and, ultimately, resistance to the longer-lived drug (Bloland *et al.* 2000; Hastings and Watkins 2006). Additionally, it was been recently suggested that post-treatment anti-malarial activity drug profiles should be considered when designing new drug combination therapies, rather than simply the drugs half-lives (Hastings and Hodel 2014).

**Table 1.1** – Half-lives of antimalarials (Ashley *et al.* 2007; WHO 2010b; Croft *et al.* 2012).

<b>Compound</b>	<b>Half-life</b>
<b>Artemisinin derivatives</b>	
Artemisinin	1 h
Dihydroartemisinin	45 min
Artemether	1h
Artesunate	45 min
<b>ACT partner drugs</b>	
Lumefantrine	3 days
Pyrimethamine	4 days
Sulfadoxine	4-9 days
Amodiaquine (Monodesethylamodiaquine*)	3 h (9-18 days)
Mefloquine	21 days
Piperaquine	5 weeks
Pyronaridine	13 days
<b>Other antimalarials</b>	
Quinine	11-18 h
Chloroquine	1-2 months
Primaquine	3-6 h
Atovaquone	60-70 h
Tetracycline	8 h
Doxycycline	10-24 h
Clindamycin	2-3 h

\* Monodesethylamodiaquine – amodiaquine primary active metabolite



Fixed-dose ACTs are now the gold standard treatment with six recommended for first-line treatment of uncomplicated malaria in adults and children (WHO 2010b; EMA 2012):

- Artemether-lumefantrine – Coartem (Novartis/ Chinese Academy of Medical Military Sciences/MMV);
- Artesunate-amodiaquine - Coarsucam (Sanofi-Aventis/DNDi/MMV);
- Artesunate-mefloquine – ASMQ (Farmanguinhos/DNDi/Cipla);
- Artesunate + sulfadoxine-pyrimethamine - AS+SP;
- Dihydroartemisinin-piperaquine – Eurartesim (Sigma-Tau/MMV/Pfizer);
- Artesunate-pyronaridine - Pyramax (Shin Poong Pharmaceuticals).

## 1.7. ANTIMALARIAL DRUG RESISTANCE

Antimalarial drugs remain as one of the most powerful tools in the fight against malaria and the development of resistance to these compounds is probably the greatest problem faced by malaria control programmes.

The emergence of CQ resistance was considered responsible for a dramatic increase in child mortality and morbidity in Africa in the 1980's and 90's (Trape 2001) and nowadays, resistance to nearly all established antimalarial compounds has been reported.

In the last decade, first line treatment with ACTs has played a major role in reducing malaria burden (Dondorp *et al.* 2011). Currently no alternative antimalarial treatment offers the same level of efficacy and tolerability as ACTs (WHO 2013a). Therefore, the emergence and spread of ART resistance would be a serious threat to the elimination/eradication efforts.

### 1.7.1. EMERGENCE OF DRUG RESISTANCE

The development of genetically determined resistance in a pathogen under drug pressure is a two step process; 1) de-novo emergence of the new genotype, 2) subsequent spread through the pathogen population. Resistance arises through spontaneous point mutations or gene duplications, mainly during asexual reproduction. A single genetic event may be all that is required, or multiple independent events may be necessary. The 'de-novo mutation' emergence is a rare event in malaria and is thought to be independent of drug selection pressure (White and Pongtavornpinyo 2003). In the presence of the drug, these mutants can survive and expand in numbers to generate gametocyte densities sufficient for subsequent spread (White and Pongtavornpinyo 2003; Barnes and White 2005; Hastings 2006). The drug pressure provides a selective advantage to resistant parasites and their frequency in the population increases (Olliaro and Taylor 2004). The resistant parasites are then transmitted in the human population by the mosquitoes. Genetic recombination occurs after fertilization in the mosquito stages consequently if one mosquito bites two people carrying different gametocytes or bites one person carrying more than one parasite genotype, the recombination with the formation or breakdown of multigenic resistance can occur (Barnes and White 2005). The parasites carrying the mutant alleles are selected if antimalarial drug concentrations are sufficient to suppress the development of susceptible parasites but insufficient to inhibit the newly arisen mutants, a phenomenon known as "drug selection" (White 1998b). Once drug resistant parasites have emerged and are selected over sensitive ones it is difficult to avoid the spread of resistance.

Advances in the understanding of the mechanisms of drug action during the last two decades have led to the identification of the putative drug resistance molecular targets, for some antimalarial drugs. The genetic basis of parasite resistance, which in some cases does not involve the molecular target, was also identified in some antimalarial drugs. The genetic events that confer antimalarial drug resistance include single point mutations in or changes of copy numbers of genes encoding drug targets, such as important enzymes, or in genes encoding pumps that affect intraparasitic drug concentrations. These mechanisms will be discussed in detail in the next section.

### 1.7.2. DEFINITION OF ANTIMALARIAL DRUG RESISTANCE

Antimalarial drug resistance has been defined as the “ability of a parasite strain to survive and/or multiply despite the administration and absorption of a drug given in doses equal to or higher than those usually recommended but within tolerance of the subject”. This definition was later modified to specify that the drug in question must “gain access to the parasite or the infected red blood cell for the duration of the time necessary for its normal action” (Bruce-Chwatt 1986; WHO 2010a).

Due to the particular mode of action of ARTs, the definition of artemisinin resistance has been a controversial issue. According to the WHO (WHO 2014), *in vivo* ART resistance is suspected when an increased parasite clearance time is observed (as evidenced by  $\geq 10\%$  of cases with parasites detectable by microscopy on day 3 after ACT treatment). Resistance is confirmed when treatment failure happens after treatment with an oral ART based monotherapy with adequate antimalarial blood concentration, as evidenced by persisting parasitaemia on day 7 post-infection, or the presence of parasites on day 3 and recrudescence within 28/42 days (WHO 2011a).

### 1.7.3. ASSESSMENT AND MONITORING OF RESISTANCE IN *P. FALCIPARUM*

The emergence of resistant mutants has resulted in reduced efficacy of several drugs and drug combinations in some regions. Drug efficacy surveillance is necessary to ensure the correct management of clinical cases and early detection of changing patterns of resistance. This monitoring is needed to inform treatment policies in malaria-endemic countries allowing the deployment of effective antimalarial drugs (WHO 2003). Three approaches have been used to evaluate the efficacy of an antimalarial drug in a given setting: clinical *in vivo* studies (also known as therapeutic efficacy testing), *in vitro* susceptibility testing, and more recently, molecular markers (WHO 2003). There are advantages and disadvantages with each of these assays.

In discussing these different approaches, it is fundamental to differentiate intrinsic parasite resistance from treatment failure, which is the inability to clear parasitaemia and/or resolve clinical symptoms after treatment. Parasite intrinsic susceptibility is only

one of several factors that can determine the outcome of the treatment; treatment failure can also be caused by incorrect drug dosing, poor drug quality and poor treatment compliance, interactions with other drugs or inadequate drug absorption (Laufer 2009).

- *IN VIVO* TESTS

Susceptibility of *P. falciparum* to antimalarial drugs is commonly assessed by therapeutic response (*in vivo* testing) (WHO 2003). One of the key characteristics of these tests is the ability to evaluate the actual clinical and epidemiological responses. Those responses involve a complex interaction between the drugs, the parasites, and the host (i.e. the therapeutic response of currently circulating parasites infecting the current population in which the drug will be used), while *in vitro* tests measure only the interaction between the blood stage parasites and the drugs (Talisuna *et al.* 2004).

*In vivo* tests involve the treatment of symptomatic *P. falciparum* infected patients with a standard dose of an antimalarial drug and subsequent follow-up of clinical and parasitological outcomes of treatment during 28-day, or even 42-day, follow-ups (Stepniewska *et al.* 2004), where the patient's clinical and parasitological response is categorized as "early treatment failure", "late clinical failure", "late parasitological failure" or "adequate clinical and parasitological response". This procedure allows the detection of any reappearance of symptoms or signs of clinical malaria and the detection of parasites in the blood as an indication of reduced sensitivity to a particular drug (WHO 2003).

Due to the influence of factors such as patient's immunity, variations in drug absorption and metabolism, and possible misclassification of new infections as recrudescence, the results of a therapeutic efficacy test do not necessarily reflect the real level of antimalarial drug resistance (Marfurt *et al.* 2010). These studies include other drawbacks: the long duration of patient monitoring that may result in high loss to follow-up; treatment administration must be supervised; the quality of the drugs has to be verified and the assessment of resistance to one drug regimen only (Laufer 2009).

However, these tests provide decision-makers with a simple, readily comprehensible indicator of the efficacy of an antimalarial drug with reduced requirement for equipment and supplies, when compared with *in vitro* tests (WHO 2003).

- *IN VITRO* TESTS

The *in vivo* method has helped the inference of treatment failure thresholds that are critical for adjusting antimalarial drug policies, but it is not considered enough on its own to confirm drug resistance (WHO 2003).

To support the evidence of a failing antimalarial regimen, a dose-response (*in vitro*) test can provide a more precise measure of drug sensitivity under controlled experimental environment, which removes variables such as patient immunity, initial parasite load, re-infection and pharmacokinetics. *In vitro* tests allow a more objective approach to parasite resistance, since in these studies the parasite will be in direct contact with incremental drug concentrations. Furthermore, several tests can be carried out with the same sample, and several drugs can be assessed simultaneously, including drugs that are still at the experimental stage (WHO 2003).

There are several *in vitro* readout methods, which differ with respect to the measured effect and the duration of exposure to the test compound. These include microscopic examination of blood films for the WHO mark III test (inhibition of maturation or replication; Giemsa-stained), the radioisotopic test (incorporation of hypoxanthine), the enzyme-linked immunosorbent assay (ELISA) with antibodies directed against *Plasmodium* lactate dehydrogenase or histidine-rich protein II (Noedl *et al.* 2002; Olliaro 2005) and fluorometric assays with DNA binding fluorescent dyes (Noedl *et al.* 2003; Corbett *et al.* 2004). These assays turn out to be more important with the increasing use of combination therapy, since they can be used to monitor susceptibility to each drug in a combination (Vestergaard and Ringwald 2007).

The *in vitro* drug sensitivity assays are very useful but they have significant disadvantages. These methods are very costly and time consuming, requiring very well trained personnel with access to advanced laboratory facilities capable of performing parasite culture (Basco and Ringwald 2000). Even when provided with such facilities some aspects of the parasite might be lost during long term adaptation to ideal conditions (LeRoux *et al.* 2009). Moreover, in part because these tests remove the host factors, the correlation of *in vitro* response with clinical response is not always reliable and is not well understood. The requirement of some prodrugs to be metabolized *in vivo* is also a drawback of *in vitro* tests.

*In vitro* drug sensitivity data may provide early evidence of increasing drug tolerance prior to parasitological/clinical resistance. Conversely, it may give misleading indications if the changes in sensitivity do not ultimately translate into parasitological/clinical resistance (Hastings *et al.* 2007).

Once the genetic changes associated with resistance are identified, drug resistance can be confirmed with molecular techniques.

- **MOLECULAR MARKERS**

Molecular markers for drug resistant malaria offer promising advantages to the methods described above and are essential public health surveillance tools (Plowe *et al.* 2007). Examination of molecular markers allow the assessment of a large number of samples and is less expensive compared with clinical studies involving more patient care and follow-up (Ekland and Fidock 2008). Sample collection, storage and transport of specimens for subsequent molecular analysis is far easier than for *in vitro* tests (WHO 2003). In the era of combination therapies, molecular markers of resistance can discriminate associations between individual mutations and the response to each drug (Picot *et al.* 2009). Furthermore, monitoring of molecular markers may also help in tracking the rates of resistance in a certain area after withdrawal of an antimalarial drug, where it would be unethical to conduct *in vivo* tests (Kublin *et al.* 2003).

Molecular markers for drug resistant malaria are based on genetic changes that confer parasite resistance to drugs. These genetic mechanisms of *P. falciparum* drug resistance have not been completely elucidated in every case. However, relatively well defined molecular markers of resistance have been established for the principal chemical families of antimalarials in current use. Multiple mutations in the *P. falciparum* chloroquine resistance transporter (PfCRT) confer resistance to CQ (Ecker, Lehane, Clain, *et al.* 2012). Mutations in the P-glycoprotein homologue (Pgh1) encoded by *pfmdr1* (*P. falciparum* multidrug resistance gene 1) may further modulate the extent of CQ resistance (Fidock *et al.* 2000; Reed *et al.* 2000). Polymorphisms and/or amplification of *pfmdr1* have also been shown to affect the susceptibility to structurally unrelated antimalarial drugs, including mefloquine, artesunate, lumefantrine and QN (Price *et al.* 1996; Sidhu *et al.* 2005).

Resistance to SP is conferred by mutations in the *dihydropteroate synthase (pfdhps)* and *dihydrofolate reductase (pfdhfr)* genes, respectively (Gregson and Plowe 2005; Muller and Hyde 2013). Atovaquone resistance is linked to mutations on the cytochrome *b* gene. The *pfnhe-1* gene, which encodes a putative  $\text{Na}^+/\text{H}^+$  exchanger has been associated with QN resistance, but additional studies are needed to validate this marker (WHO 2010a).

Disadvantages of the molecular surveillance include the need for sophisticated equipment and well trained personnel and the fact that only a limited number of genes involved or potentially involved in *P. falciparum* antimalarial drug resistance have been identified. Similar to the limitations of *in vitro* tests, the presence of particular molecular marker does not necessarily directly predict treatment outcome, especially when resistance involves more than one gene locus and/or multiple mutations (Sidhu *et al.* 2002). The presence of mutations in the above genes contributes to drug failure but the final outcome is not certain: some patients with “resistant” alleles clear the infection, and some patients with “sensitive” alleles failed treatment. Consequently we should consider that mutations increase the probability of drug failure that ultimately depends on factors such as host immune response, the drug dose taken, and variation in drug absorption and metabolism (Hastings 2007).

These methods should be considered as complementary rather than competing sources of information about drug resistance, with critical treatment strategy implications.

## 1.8. MODES OF ACTION AND MECHANISMS OF PARASITE RESISTANCE

Several studies on the underlying mechanisms of drug resistance have shown that parasite survival can be achieved by one or more of the following mechanisms:

**Alterations in the drug target** -The parasite can eliminate the drug target, inducing an alternative pathway; can alter the target’s affinity for the drug, by the introduction of mutations in the target gene, or can overexpress the drug target (gene amplification);

**Drug target unchanged** - The parasite can alter the intracellular drug levels by the development of drug transporters that modulate the uptake or export of the drug;

**Dormancy** - Parasites can go into a state of quiescence where they are protected from the drug lethal effects, but are able to recover at a later stage and resume normal growth, after cessation of therapy;

**Overexpression of biological mechanisms to handle the drug effects** - overexpression of genes involved in the DNA repair mechanism or in the oxidative stress response.

Current knowledge on the mechanism of action, resistance and on the molecular markers of resistance is summarized below.

- **Quinolines and related compounds**

All quinolines, with the exception of primaquine, are thought to exert an antimalarial action by interfering with the formation of haemozoin, within the parasite's digestive vacuole (Muller and Hyde 2010). During the intraerythrocytic development, *P. falciparum* digests 60-80% of the erythrocyte haemoglobin content to obtain a major source of its amino acid requirements and to avoid the erythrocyte premature rupture (Krugliak *et al.* 2002; Lew *et al.* 2003). A byproduct of haemoglobin digestion is free haem that is toxic to the parasite, as it causes lethal changes to membranes and proteins. To avoid haem toxicity the parasite converts it into an insoluble form called haemozoin (Bray, Ward, *et al.* 2005).

### **Quinine**

The mode of action of QN is only partially understood. QN shares some common characteristics with other quinoline antimalarial drugs such as CQ. QN, like CQ, accumulates in the parasite's digestive vacuole and can interact with haem, but binds to it with lower affinity than CQ (Sullivan *et al.* 1998; Sanchez *et al.* 2008). For that reason, it was hypothesized that QN also acts through haem detoxification inhibition (Foley and Tilley 1997; Fitch 2004). However is not clear whether haem is the only or even the major target for QN.

Despite the widespread use of QN in the nineteenth century, high level resistance to the drug has been very slow to develop. The first documented reports of QN resistance are



from 1910 (Peters 1982; Mwangi and Ranford-Cartwright 2013). However, high levels of resistance are rare and limited (Wongsrichanalai *et al.* 2002; Okombo *et al.* 2011). The slow development and spread of QN resistance was possibly a result of a multigenic response of the parasite (Ferdig *et al.* 2004; Nkrumah *et al.* 2009). In fact, the genetic basis for resistance to QN has been associated with several genes, probably working synergistically. Currently, 4 genes have been identified: *P. falciparum* chloroquine resistance transporter gene (*pfcr1*) (Cooper *et al.* 2002; Cooper *et al.* 2007), the multidrug resistance transporter 1 gene (*pfmdr1*) (Reed *et al.* 2000; Sidhu *et al.* 2006) and more recently the resistance protein gene (*pfmrp*) (Mu *et al.* 2003) and the sodium/proton exchanger 1 (*pfneh1*) (Ferdig *et al.* 2004).

### Chloroquine and Amodiaquine

Despite years of research, the exact mechanism of CQ remains a controversial area. CQ is a diprotic weak base and diffuses freely between the extracellular matrix and the acidic digestive vacuole of the parasite. After diffusing to the vacuole, CQ becomes protonated and since membranes are not permeable to charged species, CQ becomes trapped (Homewood *et al.* 1972; Ferrari and Cutler 1991). This ion-trapping mechanism leads to CQ accumulation inside the digestive vacuole (Hawley *et al.* 1996). In the digestive vacuole, CQ binds to haem, which prevents its polymerization into haemozoin. This leads to accumulation of the toxic free haem and later on to oxidative stress and membrane damage within the parasite (Sullivan *et al.* 1998; Warhurst *et al.* 2007; Roepe 2009)

CQ was a victim of improper use. In the early 1960s, CQ was included in table salt and used in population based prophylaxis regimens in an effort to eradicate malaria (Peters 1987). Unfortunately, shortly afterwards, the first cases of CQ resistance emerged in the same areas where chloroquinized salt was distributed (Foley and Tilley 1998). Regardless of the extensive use of the drug, there was nearly a 20 year lag between the introduction of CQ in 1950s and the widespread occurrence of resistance, suggesting a complex mechanism of resistance implicating multiple mutations or several genes. The first cases of CQ resistant parasites came from South America (Columbia, Brazil and Venezuela) in 1960 (Wernsdorfer 1991) and these were followed soon afterwards by sporadic reports of resistance in Southeast Asia (Thailand and Kampuchea) in 1961 (Wernsdorfer 1991). By 1973 CQ resistance was widespread in South America and Asia. Molecular epidemiological

studies suggest that resistance then spread from Southeast Asia to Africa in the late 1970s, when its emergence was first reported in Kenya and Tanzania (Campbell *et al.* 1979; Fogh *et al.* 1979).

CQ resistant parasites accumulate less CQ in the digestive vacuole than sensitive strains, consequently keeping the drug concentration below toxic levels (Saliba *et al.* 1998; Bray, Ward, *et al.* 2005). Studies of a genetic cross between HB3 (CQ sensitive) and Dd2 (CQ resistant) strains have shown that resistance is mainly determined by the selection of a mutant form of PfCRT protein (Wellems *et al.* 1991; Su *et al.* 1997; Fidock *et al.* 2000). PfCRT, has since been shown to localize in the parasite's digestive vacuole (Fidock *et al.* 2000; Cooper *et al.* 2002), where it can control the access of CQ to haem. Furthermore, bioinformatic analyses predict PfCRT to be a member of the "drug/metabolite transporter" superfamily (Martin and Kirk 2004). The normal physiological function of PfCRT is still poorly understood and at the moment there are two main theories proposed; PfCRT can act as either a channel (allowing protonated CQ to exit the digestive vacuole) or as an active transporter protein (Warhurst *et al.* 2002; Bray *et al.* 2006; Sanchez *et al.* 2007).

Linkage studies demonstrated an association between an amino acid substitution at position 76 from lysine to threonine (K76T) and CQ resistance in culture adapted isolates from different geographic areas (Fidock *et al.* 2000). The importance of the K76T mutations appears to be due to the loss of positive charge within the channel. This mutation is predicted to alter the selectivity of the protein such that it is able to transport the positively charged CQ allowing its exit from the digestive vacuole, and therefore away from its site of action (Warhurst *et al.* 2002; Lehane and Kirk 2008).

Genetic sequencing has revealed that other changes occur in combination with K76T which have different geographic distributions and different drug resistant phenotypes (Bray, Martin, *et al.* 2005; Sa *et al.* 2009). These extra mutations are possibly compensatory mutations for unfavorable changes in the normal function of PfCRT (Hyde 2007). CQ resistant forms are classified by the amino acid positions 72-76: CVMNK is the sensitive haplotype; the SVMNT and CVIET are the resistant haplotypes, although there are many other rarer haplotypes at these residues found in the field (Cooper *et al.* 2005; Summers *et al.* 2012). CVIET is by far the most dominant mutant haplotype in Africa and also found in Southeast Asia and South America, while SVMNT haplotype had been reported mainly in South America (Fidock *et al.* 2000; Cooper *et al.* 2005; Gama *et al.* 2010), Papua New Guinea (Mehlotra *et al.* 2001) and in the Philippines (Chen *et al.* 2005).

Another gene associated with CQ resistance is *pfmdr1*. *Pfmdr1* encodes a homologue of mammalian multidrug resistance gene (*mdr1*) called P-glycoprotein homolog 1 (Pgh1) (Foote *et al.* 1990). When mutant PfCRT is present mutations on *pfmdr1* have been found to modulate the degree of CQ sensitivity, particularly mutations at codon positions 86, 184, 1034, 1042 and 1246 (Sa *et al.* 2011; Ecker, Lehane, Clain, *et al.* 2012). Interestingly amplification of wild type form of this gene has been implicated in increased CQ sensitivity (Price *et al.* 2004; Sa *et al.* 2011). On the contrary, parasites with multiple copies of *pfmdr1* appear to be less sensitive to mefloquine, QN and ARTs (Sidhu *et al.* 2005).

Amodiaquine is an important ACT partner drug, since artesunate-amodiaquine is presently the second most commonly used ACT in the world (Zwang *et al.* 2014). Amodiaquine is structurally related to CQ and is rapidly metabolised *in vivo* into monodesethylamodiaquine, its primary metabolite. Based on structural similarity, amodiaquine is hypothesized to act also by inhibiting haem detoxification. Furthermore, like CQ, amodiaquine has been shown to accumulate within the digestive vacuole, bind to haem and to inhibit haem polymerization *in vitro*, with a similar efficiency to CQ (Foley and Tilley 1998; Hayeshi *et al.* 2008).

Cross resistance between CQ and amodiaquine has been reported however, strains of *P. falciparum* resistant to CQ are not necessarily also resistant to amodiaquine (Sa *et al.* 2009). Resistance to amodiaquine has been associated with the 76T mutation in *pfcr1* (Ochong *et al.* 2003). Furthermore, the strongest association with amodiaquine *in vitro* resistance has been found with the *pfcr1* SVMNT haplotype. The SVMNT haplotype is associated with high levels of amodiaquine resistance, but only moderately resistance to CQ, whereas the CVIET haplotype is linked to greater resistance to CQ and moderate resistance to amodiaquine (Sa *et al.* 2009). This association was also establish *in vivo* by Beshir *et al.*, who described that the presence of the SVMNT haplotype is enough to confer amodiaquine resistance (Beshir, Sutherland, *et al.* 2010). The effects of the *pfcr1* haplotypes in amodiaquine resistance is further modulated by mutations in *pfmdr1* (Sa *et al.* 2009). The *pfmdr1* polymorphisms 86Y, 184Y and 1246Y (YYY haplotype) were found to be selected after treatment with amodiaquine monotherapy or artesunate-amodiaquine combination therapy in East Africa (Holmgren *et al.* 2007; Humphreys *et al.* 2007; Nsobya *et al.* 2007)

### **Pyronaridine**

Pyronaridine is highly active against erythrocytic stages of malaria parasites but its mechanism of action is not yet understood. Some studies suggested that pyronaridine can interfere with the food vacuole of the parasite (Croft *et al.* 2012) while other studies reported that pyronaridine inhibits the decatenation activity of *P. falciparum* topoisomerase II (Chavalitshewinkoon *et al.* 1993). Pyronaridine is also thought to target  $\beta$ -hematin formation. Additionally, it can interfere with a glutathione-dependent heme degradation process by forming a drug-haematin complex and inducing the lysis of the red blood cells (Auparakkitanon *et al.* 2006).

There are conflicting reports on *in vitro* cross resistance between pyronaridine and CQ. In some studies pyronaridine does not appear to show cross-resistance with CQ (Basco and Le Bras 1992; Chang *et al.* 1992; Ringwald *et al.* 1996) although in other studies evidence of cross resistance between the two drugs is found (Schildbach *et al.* 1990; Pradines *et al.* 1998; Caramello *et al.* 2005). On the other hand, clinical trials have shown that pyronaridine has good efficacy against CQ resistant strains (Looareesuwan *et al.* 1996; Ringwald *et al.* 1996; Ringwald *et al.* 1998).

The use of pyronaridine has been limited to China therefore it is expected that resistance will be slow to develop across other regions with malaria. However, *in vitro* studies indicate that the sensitivity to this drug decreased in China between 1988 and 1995 (Yang *et al.* 1997). These data suggest that the resistance to pyronaridine may have already developed but the molecular mechanism is unknown.

### **Primaquine**

Primaquine (probably as its metabolites) is active against gametocyte and hypnozoite stages and its mode of action appears to be quite distinct from all the other quinolines. However, the precise mechanism of action is still unknown. Treatment with primaquine causes swelling and thickening of the mitochondria of tissue stage parasites suggesting that it exerts its activity by disrupting the metabolic processes of parasite mitochondria. Possibly by interference with the ubiquinone function (Vale *et al.* 2009), in a similar way to atovaquone, which has been shown to inhibit the cytochrome *bc<sub>1</sub>* complex of the

mitochondrial respiratory chain and collapse the mitochondrial membrane potential (see atovaquone section for more details) (Foley and Tilley 1998).

The activity of primaquine against gametocytes and dormant stages has been attributed to the inability of these stages to repair damaged mitochondria (Warhurst 1984) and the damage is possibly caused by the primaquine-induced production of highly reactive metabolites that generate toxic intracellular oxidative potentials (Hill *et al.* 2006).

Resistance to primaquine is rarely reported (White 2004; Vale *et al.* 2009) and the possible mechanism of resistance is unknown.

### **Piperaquine**

Due to structural similarities with CQ, it was postulated that piperaquine and CQ share a similar mode of action. Studies have shown that piperaquine concentrates in the digestive vacuole and that it is a potent inhibitor of haem polymerization (Raynes 1999; Warhurst *et al.* 2007) however, the exact mechanism of action of piperaquine is still unknown.

Resistance to piperaquine is known to have developed in China where this drug was used intensively in the late 1970s (Tran *et al.* 2004) resulting in the subsequent decline in its use (Davis *et al.* 2005). There are high rates of piperaquine resistance in China but the genetic determinant has not yet been identified (Hao *et al.* 2013).

*In vivo* studies on African *P. falciparum* isolates have demonstrated that piperaquine does not exhibit cross-resistance with CQ and that modulation of piperaquine resistance is not modulated by mutations in the *pfcr*t gene (Pascual *et al.* 2013). Moreover, piperaquine has excellent activity against CQ resistant parasites indicating that these two drugs have different resistant mechanisms. This characteristic can be explained by the fact that piperaquine has four positive charges and may be more efficiently trapped inside the digestive vacuole or by its steric bulk (the amount of space that the piperaquine molecule occupies), which prevents it from fitting into the binding site of PfCRT (O'Neill *et al.* 2012b).

Recently, studies have suggested that a copy number variation on chromosome 5 (not *pfmdr1*) is associated with piperaquine resistance *in vitro* (Eastman *et al.* 2011).

## Mefloquine

Mefloquine competitively inhibits CQ accumulation, and vice-versa, suggesting that they share the same mechanisms of accumulation (Foley and Tilley 1998). However, mefloquine interacts weakly with free haem with corresponding less effect on haem polymerization, when compared with CQ (Dorn *et al.* 1998). Mefloquine is a much weaker base than CQ and should accumulate less well, in the acidic digestive vacuole. Nevertheless, is a more potent inhibitor of the growth of drug-sensitive strains than CQ (Foley and Tilley 1998). Therefore, these observations suggest that these drugs interact at different points within the haemoglobin degradation pathway or that other targets are implicated in the mefloquine mode of action (Foote and Cowman 1994; Foley and Tilley 1998).

Mefloquine resistance was reported from the Thai-Myanmar and the Thai-Cambodian borders in 1982, where mefloquine was used intensively as treatment for uncomplicated malaria (Wongsrichanalai *et al.* 2001; White 2004). Resistance is not widespread and mefloquine is still effective outside SE Asia and in some regions of South America.

The exact mechanism of mefloquine resistance is still unclear, although studies conducted in the Greater Mekong subregion (Cambodia and Thailand) report that mefloquine resistance is associated with an increase in the parasite *pfmdr1* copy number (Price *et al.* 2004). Furthermore, *in vitro* susceptibility to mefloquine and QN increased when the parasites carried *pfmdr1* mutations (S1034C/N1042D/D1246Y) and decreased when the wild-type *pfmdr1* copy number was increased (Sidhu *et al.* 2005; Sidhu *et al.* 2006; Chaijaroenkul *et al.* 2010).

One interesting observation is that there seems to be an inverse relation between mefloquine and CQ sensitivity. Thus, the selection for high levels of mefloquine resistance and the presence of increased *pfmdr1* copy number are often associated with increased sensitivity to CQ and vice versa (Hayton and Su 2004). The MDR1-Pgh1 protein is localized on the digestive vacuole membrane (Cowman *et al.* 1991), where it functions as a transporter (Rohrbach *et al.* 2006), and has been identified as a possible modulator of resistance to a diverse range of antimalarial drugs probably by directly or indirectly removing the drugs from their sites of action (Rubio and Cowman 1996). It is believed that the site of action of CQ is the digestive vacuole, consequently concentrating the drug in this compartment may be prejudicial for the parasite; on the contrary, the accumulation of mefloquine (and artemisinin) in the digestive vacuole may be advantageous to the parasite

if the drug has a different target site. Alternatively, it has been suggested that Pgh1 may be the molecular target of mefloquine (Rubio and Cowman 1996; Gavigan *et al.* 2007).

### **Lumefantrine**

The mechanism of action of lumefantrine is not known. Lumefantrine inhibits haemozoin formation suggesting that lumefantrine, like CQ, interferes with haemoglobin detoxification (Combrinck *et al.* 2013). This might be one but not the only mechanism of action of lumefantrine. In fact, a recent study suggests that lumefantrine exerts its antimalarial action by interfering with membrane phospholipids (Mwai *et al.* 2012).

Lumefantrine has never been used as monotherapy and resistance to lumefantrine in field isolates has not yet been convincingly demonstrated (Kokwaro *et al.* 2007). However, lumefantrine tolerant parasites were reported in isolates from Tanzania after treatment with artemether-lumefantrine. This phenotype was associated with polymorphisms in PfMDR1, particularly the wild type variant N86 (Sisowath *et al.* 2007) and with amplifications in PfMDR1 (Price *et al.* 2006; Sisowath *et al.* 2007). Additionally, parasites with the wild type PfCRT show reduced susceptibility to lumefantrine (Sisowath *et al.* 2009; Eyase *et al.* 2013).

More recently, lumefantrine tolerance *in vitro* was associated with changes in gene expression profiles on 184 *P. falciparum* genes, detected using microarray assays. Among those are known and putative transporters, including the *pfmdr1* gene and the multidrug resistance associated protein and the V-type H<sup>+</sup> pumping pyrophosphatase 2 (*pfvpp2*) although, further validation is needed to confirm the role of these genes on lumefantrine resistance (Mwai *et al.* 2012).

### **Atovaquone**

Atovaquone is a structural analogue of protozoan ubiquinone (also called coenzyme Q), a vitamin like substance involved in electron transport in the mitochondria (Baggish and Hill 2002). Atovaquone binds irreversibly to the mitochondrial cytochrome *bc<sub>1</sub>* complex of *P. falciparum* inhibiting the natural function of ubiquinone. Ubiquinone participates in mitochondrial membrane electron transport by accepting electrons from a number of dehydrogenase enzymes and passing them to the cytochromes. Since blockage of the

electron transport chain means that dihydroorotate dehydrogenase, a key enzyme in pyrimidine biosynthesis, is unable to transfer electrons to ubiquinone, blockage of the electron transport chain ultimately inhibits *de novo* pyrimidine biosynthesis. The inhibition of electron transfer in the mitochondrion not only results in inhibition of pyrimidine biosynthesis but also collapses the parasite mitochondrial membrane electrochemical potential, two essential processes that contribute to parasite death (Srivastava *et al.* 1997; Baggish and Hill 2002; Biagini *et al.* 2006). Atovaquone acts on all growing stages of the life cycle due to its antimitochondrial activity, but does not affect hypnozoites.

Within only a few years of application in the field atovaquone resistance was observed with point mutations in the cytochrome *b* gene, principally affecting position 268, either exchanging a tyrosine for a serine (Y268S) (Korsinczky *et al.* 2000; David *et al.* 2003; Farnert *et al.* 2003; Schwobel *et al.* 2003; Legrand *et al.* 2007; Musset *et al.* 2007) or less frequently for asparagine (Y268N) (Fivelman *et al.* 2002) or for cysteine (Musset *et al.* 2007; Sutherland *et al.* 2008), associated with drastic reductions in parasite susceptibility to the drug.

- Antifolate-resistance

The malaria parasite is unable to consume pyrimidines already synthesized by the host and for that reason must produce its own (Le Bras and Durand 2003). Pyrimethamine is a potent inhibitor of the dihydrofolate reductase (DHFR) enzyme which is encoded by the *dhfr* gene that exists as a bifunctional enzyme together with thymidylate synthase (TS) (Ivanetich and Santi 1990), while sulfadoxine targets the dihydropteroate synthetase (DHPS) domain of the bifunctional 7,8-dihydro-6-hydroxymethylpterin pyrophosphokinase-DHPS enzyme, encoded by the *dhps-pppk* gene (Brooks *et al.* 1994). Both enzymes are part of the parasite folate synthetic pathway and the inhibition of these enzymes leads to interruption of the DNA synthesis and nuclear division. Unfortunately, *falciparum* parasites are able to quickly accumulate multiple genetic mutations producing enzymes resistant to such drugs (Sibley *et al.* 2001) (Hyde *et al.*, 2007).

Resistance to pyrimethamine occurred soon after its deployment as antimalarial (Petersen 1987) and resistance to the SP combination was reported rapidly after its introduction in both Southeast Asia and the Amazon basin in the mid-1970s (White 1992; Anderson and Roper 2005). The expansion of SP resistance did not happen as quickly as



the expansion to CQ resistance, in Africa the emergence of SP resistance was only reported in the 1990s, in Tanzania (Ronn *et al.* 1996). Even nowadays, SP treatment failure due to high-level parasite resistance is widespread in South America and Asia and is common in East Africa, although SP retains some efficacy in West Africa (WHO 2010a).

The mechanism of resistance is attributed to mutations in the encode drug targets (*dhfr* and *dhps* genes) of *P. falciparum*. Both the *dhfr* and *dhps* gene mutations occur in a progressive stepwise manner, with higher levels of resistance occurring in the presence of multiple mutations. A point mutation at position 108, changing a serine to an asparagine (S108N), in the *dhfr* gene product is the first step for acquiring increased resistance to pyrimethamine. Addition of subsequent mutations at positions 50, 51, 59, and 164 increases the level of pyrimethamine resistance (Peterson *et al.* 1988; Snewin *et al.* 1989). Mutations at amino acid positions 436, 437, 540, 581 and 613 in DHPS decrease this enzyme's affinity for sulfadoxine. Like DHFR, the increasing of *in vitro* resistance to sulfadoxine is generally associated with the number of amino acid substitutions in the DHPS enzyme. An alanine to glycine substitution at position 437 (A437G) has been proposed as the first step to sulfadoxine resistance (Wernsdorfer and Noedl 2003).

These mutations reduce the binding affinity of the drugs to their targets while still enabling the parasite to manipulate the folic acid synthesis pathway for its own benefit (Snewin *et al.* 1989; Wernsdorfer and Noedl 2003).

- Antibiotics

The mechanism of action of antibiotics against malaria parasites is unclear however they are thought to act against the parasite by inhibiting protein synthesis, as they do in bacteria (Warhurst 1986). Tetracyclines (tetracycline and doxycycline) and lincosamides (clindamycin) antibiotics exert their antibacterial effects by interfering with 70S ribosomes (Clough and Wilson 2001). In *P. falciparum*, tetracyclines have been reported to inhibit mitochondrial proteins, decrease dihydroorotate dehydrogenase activity, an enzyme of the pyrimidine pathway (Briolant *et al.* 2010). In addition, it was shown that clindamycin, doxycycline and azithromycin, cause "delayed death" by disruption of apicoplast function (Dahl *et al.* 2006; Dahl and Rosenthal 2007), though the precise mechanism remains uncertain. Studies in a mouse model revealed that the antibiotics inhibit apicoplast biogenesis in the liver stage. These drugs do not prevent the maturation of the merozoites

in the liver, but the produced daughter cells cannot establish a viable red blood cell infection. For this reason, the antibiotics are being investigated for a new vaccination strategy against malaria (Friesen *et al.* 2010).

No clinical malaria failure with the tetracycline doxycycline have been reported yet, however different phenotypes of susceptibility to doxycycline have been identified among *P. falciparum* clinical isolates (Briolant *et al.* 2009). These different phenotypes have been associated with *pfmdt* (a putative drug/metabolite transporter gene) and *pftetQ* (a putative tetQ family GTPase gene) copy number variations (Gaillard *et al.* 2013).

Clindamycin, like tetracyclines, inhibits prokaryotic protein translation, but in this case by binding to the 50S ribosomal subunit (comprising the 23S rRNA and the 5S rRNA and ribosomal proteins. Data on *P. falciparum* clindamycin resistance have been reported in 2010 and have been associated with point mutations on the apicoplast 23S rRNA. Mutations on this gene have been also associated with clindamycin resistance in bacteria (Ecker, Lehane and Fidock 2012).

- Artemisinins

ART is a sesquiterpene trioxane lactone that contains an endoperoxide bridge (C-O-O-C; Figure 1.3) that provides a structure very different from any of the previously known antimalarial drugs (i.e., quinolines and antifolates) (Klayman 1985; Hien and White 1993; Barradell and Fitton 1995). Despite several years of research, the molecular mechanism of action of ARTs remains uncertain although most studies agree that their antimalarial activity is dependent on the reactivity of the endoperoxide bridge (Avery *et al.* 1993; Meshnick *et al.* 1996; Golenser *et al.* 2006). ARTs are considered prodrugs that need to be activated before it becomes effective (Krishna *et al.* 2004b) but the mechanism responsible for ARTs activation is unclear. Early studies done by the Meshnick group (Meshnick *et al.* 1991; Meshnick 1994b) suggested that ART is activated by iron (II) to produce free toxic activated oxygen. After that two different mechanisms have been proposed that differ by their dependency on iron and contribution of carbon centred radicals. In the reductive scission model, the peroxide bridge is cleaved by low-valent transition irons (ferrous haem or nonhaem, exogenous divalent  $\text{Fe}^{2+}$ ), producing oxygen centred radicals that rearrange to produce carbon centred radicals (Posner *et al.* 1995; O'Neill *et al.* 2000; Jefford 2001; Olliaro *et al.* 2001). Alternatively, the open peroxide model, suggests that the peroxide ring

is opened by protonation ( $H^+$ ) or by complex formation with a metal iron ( $Fe^{2+}$ ). This mechanism has the potential of producing reactive oxygen species (Haynes *et al.* 2007; O'Neill *et al.* 2010).

Once activated ARTs were hypothesized to cause damage to different cellular targets present in the surrounding environment. They can impair the haem detoxification pathway by alkylating intracellular haem and inhibiting its polymerization to non toxic haemozoin (Meshnick *et al.* 1991; Robert *et al.* 2005; Creek *et al.* 2008). The free radicals generated by the ARTs activation may interfere with the proper function of key parasite proteins (Meshnick 2002; Wu *et al.* 2003) such as proteases involved in haemoglobin degradation and the translationally controlled tumor protein, a protein that binds haem (Bhisutthibhan and Meshnick 2001; Haynes *et al.* 2007; O'Neill *et al.* 2010).

Alternative views propose the sarcoplasmic endoplasmic reticulum calcium ATPase (PfATP6 or PfSERCA) gene of *Plasmodium* as a possible parasite specific target. This is based on structural similarity between ARTs and thapsigargin (another sesquiterpene lactone), an inhibitor of human sarco-endoplasmic reticulum calcium dependent ATPase (SERCA) (Eckstein-Ludwig *et al.* 2003). PfATP6 is thought to be critical for parasite survival (Vennerstrom *et al.* 2004) and studies suggested that mutations on this enzyme modulate the affinity of ART for the protein (Eckstein-Ludwig *et al.* 2003; Uhlemann *et al.* 2005). In fact, ART can inhibit the activity of ATPase6 in transfected *Xenopus laevis* oocytes (Eckstein-Ludwig *et al.* 2003), and a single amino acid substitution in ATPase6 (L263E) is enough to prevent ART's inhibitory effects (Uhlemann *et al.* 2005). Since this work was published there have been several studies which contradict this hypothesis. A subsequent study showed no antagonism between thapsigargin and artemisinin, contradicting the original work (del Pilar Crespo *et al.* 2008). The use of *P. falciparum* transgenic parasites carrying the L263E mutation showed a barely significant small reduction in the susceptibilities to ART and dihydroartemisinin, but not to artesunate when compared with the wild-type strain (Valderramos *et al.* 2010).

ART has also been shown to inhibit the respiratory chain of the mitochondria (Wang *et al.* 2010). Using a yeast model the authors proposed a dual role of mitochondria on ART mode of action: the ART is activated by the electron transport chain which generates free radicals that damage the mitochondria (Li *et al.* 2005; Wang *et al.* 2010). Furthermore, Hartwig and colleagues have shown that ARTs accumulate within neutral lipids and can damage the membranes of the parasite (Hartwig *et al.* 2009).

The first signs of suspected ART resistance were reported near the Thailand-Cambodian border (Vijaykadga *et al.* 2006) following artesunate-mefloquine, but was not possible to confirm if the ACT clinical failure was due to artesunate or the partner drug. Subsequent studies in western Cambodia and northwestern Thailand confirmed artesunate tolerance characterized by delayed clearance times after artesunate monotherapy (Noedl *et al.* 2008; Dondorp *et al.* 2009).

For now, the resistance appears to be confined to the Greater Mekong subregion and early signs of ART resistance were confirmed in at least 16 sites in Cambodia, Laos, Myanmar, Thailand and Viet Nam (WHO 2014). However, a recent study from Kenya suggested a reduced sensitivity to ART derivatives (Borrmann *et al.* 2011).

Many genes have been implicated in resistance to this class of compounds. Uhlemann and colleagues suggested that resistance to ARTs may depend on a single nucleotide polymorphism in the drug's putative chemotherapeutic target, the *pfatpase6* gene (Uhlemann *et al.* 2005). A subsequent study report that *P. falciparum* parasites from French Guiana harbouring mutant forms of the *pfATPase6* gene (S769N) displayed significantly increased IC<sub>50s</sub> to ARTs, suggesting its role in ART resistance (Jambou *et al.* 2005). However, mutations in this gene are not associated with resistance in field isolates from elsewhere (Dahlstrom *et al.* 2008; Jambou *et al.* 2010). Causal unequivocal association between mutations in the *pfATPase6* gene and resistance to ARTs has not yet been established though.

Amplification of PfMDR1 has been linked to the parasite's ability to modulate ART *in vitro* responses in previous work (Duraisingh *et al.* 2000; Reed *et al.* 2000; Price *et al.* 2004). In an attempt to clarify the role of *pfmdr1* amplification in this phenotype, Sidhu *et al.* (Sidhu *et al.* 2006) genetically abolished one of the two copies of the gene in the multi-drug parasite *P. falciparum* line FCB. *In vitro* assessment of the resulting knock-out mutant harboring a single gene copy revealed that its sensitivity to ART had approximately halved, providing the first direct evidence as to the ability of *pfmdr1* copy number to modulate this phenotype.

However, no correlation was found between *pfATPase6* or *pfmdr1* genes and *in vivo* resistance to ARTs in the first confirmed cases of resistance along the Thai/Cambodian border (Imwong *et al.* 2010).

It has since been shown that ART resistance is a heritable trait (Anderson *et al.* 2010) and different genome wide association studies have proposed several candidate genomic regions/genes associated with the Cambodian ART resistance phenotype, including a region on chromosome 13 (containing seven candidate genes) (Cheeseman *et al.* 2012), and point mutations on chromosomes 10, 13 and 14 (Takala-Harrison *et al.* 2013). However, the role in ART resistance of these new candidates needs further genetic evaluation, as do additional chromosome regions implicated in unusual population structure observed in western Cambodia, which may be linked to ART sensitivity (Miotto *et al.* 2013).

Mutations on the kelch propeller domain gene (“K13-propeller”) have recently been proposed as a molecular marker of ART resistance. Using a Tanzanian laboratory adapted strain, selected to survive high doses of ART, Arieu and colleagues found an association between mutations in seven genes and ART resistance *in vitro* (measured on small rings with only 3 hrs exposure to drug), with one of them being the K13-propeller gene (*pfk13*). Subsequently they investigated the role of these candidate genes in ART resistance, using parasite lines from Cambodia. They demonstrated that Y493H, R539T and C580Y mutations on the K13-propeller were correlated with the *in vivo* delayed parasite clearance phenotype followed by ART treatment and Y493H, I543T, R539T, and C580Y mutations were associated with a prolonged parasite *ex vivo* survival (Arieu *et al.* 2014). Additional studies have confirmed the association between clinical slow clearance phenotype from other Southeast Asian populations (Vietnam, Myanmar, Laos and Thailand) and different polymorphisms in the propeller region of *pfk13* (Amaratunga *et al.* 2014; Ashley *et al.* 2014). The polymorphisms associated with artemisinin resistance in Southeast Asia were not detected in other countries in Africa (Ashley *et al.* 2014; Taylor *et al.* 2015). However, other non-synonymous SNPs were identified in African samples with unclear phenotype (Taylor *et al.* 2015).

Recently, two independent transfection based studies have now confirmed this association. The mutation C580Y was introduced in the genome of a *P. falciparum* strain susceptible to artemisinin using the CRISPR-Cas9 system, and consequently increased the ring-stage parasite survival in presence of artemisinin (Ghorbal *et al.* 2014). In addition, parasites engineered to express K13 mutations have shown increased *in vitro* resistance in the RSA0-3h ring-stage survival assay, as well as a loss of resistance in parasites whose mutant K13 gene was reverted back to the wild-type sequence (Straimer *et al.* 2015).

### 1.9. *PLASMODIUM CHABAUDI* MODEL SYSTEM

Field studies of human malaria parasites provide a very limited amount of information about the mechanisms underlying drug resistance. Consequently, the genetic basis of drug resistance in malaria must be investigated by other ways.

An alternative approach that has been used to identify the mechanism of ART resistance is the selection of the rodent malaria parasite *Plasmodium chabaudi* under sustained drug pressure *in vivo*. One of the most appropriate ways is to use genetically stable resistant mutants selected through drug pressure from cloned sensitive parasite lines. In this way, drug sensitive and drug resistant parasites are genetically identical (isogenic) except for the mutation involved in resistance; such mutations can then be identified using different approaches like genetic linkage analysis or whole genome sequencing. *In vitro* studies with human malaria parasites present several limitations, the selection of *in vitro* resistance can be extremely laborious and it is very difficult to generate a stable drug resistant strain (Nzila and Mwai 2010). Identification of causative mutations requires controlled *in vivo* laboratory experiments, which are simply not feasible with human malarias. Therefore rodent malaria parasites have been widely used to study the mechanisms of drug resistance *in vivo* (Walker *et al.* 2000; Cravo *et al.* 2003; Ferrer-Rodriguez *et al.* 2004; Afonso *et al.* 2006a; Hunt *et al.* 2010; Rodrigues *et al.* 2010; Borges *et al.* 2011).

*Plasmodium chabaudi chabaudi* is a malaria parasite of murine rodents and it has been used as a model to study various aspects of parasite biology and disease which are difficult to investigate using human malaria parasites. There are many reasons why *P. chabaudi* is considered to be a good model for the human malaria parasite, especially in studies on drug resistance. This species shares a number of similarities in its basic biology with *P. falciparum*, including preferential invasion of mature erythrocytes, the synchronicity of their asexual blood form, sequestration of schizont-infected erythrocytes, and gametocyte development late in the infection (Carlton *et al.* 2001).

There are many different strains of *Plasmodium chabaudi* however, the AS strain has been historically used in the experimental evolution of drug resistance, resulting in a series of isogenic parasites which are resistant to many different drugs (AS lineage). These parasites were obtained over successive generations through exposure to different antimalarials (Figure 1.4 and Table 1.2). As a consequence, these parasites should have the

same genetic background, with mutation in genes involved in resistance to the drug used for the selection of each clone.

The AS isolate was originally taken from naturally infected thicket-rats (*Thamnomys rutilans*) from the Central African Republic (Carter and Diggs 1977), inoculated into laboratory mice and cloned by limiting dilution (Carter and Walliker 1975). The AS-SENS was then exposed to 75 mg/kg of pyrimethamine daily for 4 days and parasites that recrudesced after treatment were cloned and designated AS-PYR (Walliker *et al.* 1975). The AS-PYR parasite is resistant to pyrimethamine and showed the substitution of a serine to an asparagine in position 106 (S106N) in the orthologue of *P. falciparum's pfdhfr*, the *pcdhfr* gene (Cowman and Lew 1990).

AS-PYR was then selected for resistance to chloroquine by treatment with low doses of chloroquine over 15 mouse passages and a line resistant to low doses of chloroquine was obtained (Rosario 1976). Serial passages to maintain the parasites were carried out by intraperitoneal inoculation of normal mice with parasitized red blood cells from a donor mouse. Each passage was repeated every 4-7 days, depending on the development of the parasite in the mice (Rosario, 1976). This line was cloned, denoted AS-3CQ and then subjected to further stepwise increases of chloroquine over 40 mouse passages, producing a line capable of surviving intermediate doses of CQ (Padua 1981). These parasites, named AS-15CQ did not represent a clonal population, and, furthermore, underwent mosquito passaging, resulting in genetic recombination among the various parasites of the population. The AS-15CQ was subject to further increments in chloroquine pressure to select parasites resistant to high levels of CQ (Padua 1981; Carlton *et al.* 1998). This clone was denominated AS-30CQ and was subsequently used for the generation of AS-ART by stepwise increasing doses of artemisinin during 15 passages. These parasites had a 15-fold increase in the minimum curative dose to artemisinin (Afonso *et al.* 2006b). Finally, the AS-15CQ clone, served as progenitor for the generation of a second clone, AS-ATN. This clone was selected by treatment with stepwise increasing doses of artesunate during 14 passages and had a 6-fold increase in the minimum curative dose to artesunate (Afonso *et al.* 2006b).

The sensitive and resistant phenotypes are defined by *in vivo* growth recovery assays. These assays monitor the growth of parasites from an intraperitoneal inoculation under selection of a dose of drug. The time taken for parasites appearance is used as a measure of degree of resistance (Carlton *et al.*, 1998, Hunt *et al.*, 2004; Hunt *et al.*, 2007).

**Table 1.2** – Stable drug resistant mutants of *Plasmodium chabaudi* produced by drug selection.

Clone	Drug selection	Drug response			Genetic marker	Refs
		Pyrimethamine	Chloroquine	Artemisinin		
AS-SENS	None	Sensitive	Sensitive	Sensitive	/	(Carter and Diggs 1977)
AS-PYR	75mg/kg pyrimethamine (4 days)	Resistant to 10 mg/kg pyrimethamine for 4 days	Sensitive	Sensitive	<i>Pcdhfr</i> S106N (analogous to the <i>Pfdhfr</i> S108N)	(Walliker <i>et al.</i> 1975; Cowman and Lew 1990; Cheng and Saul 1994)
AS-3CQ	Increasing doses of CQ (±2 months)	Resistant	Low resistance (resistant to 3 mg/kg of CQ for 6 days)	Sensitive	<i>Pcaat1</i> (aminoacid transporter) A173E	(Rosario 1976; Carlton <i>et al.</i> 1998; Hunt <i>et al.</i> 2004; Kinga Modrzynska <i>et al.</i> 2012)
AS-15CQ	Increasing doses of CQ (±4 months)	Resistant	Intermediate resistance (resistant to 15 mg/kg of CQ for 6 days)	/	This line is uncloned (has a mix genotype)	(Padua 1981)
AS-30CQ	Increasing doses of CQ (±6 months)	Resistant	High resistance (resistant to 30 mg/kg of CQ for 6 days)	Resistant to 100 mg/kg of artemisinin for 3 days	PCHAS_031370 (transporter on chr03) T719N; <i>Pcubp1</i> V2728F	(Padua 1981; Hunt <i>et al.</i> 2007)
AS-ART	Increasing doses of artemisinin (±4 months)	Resistant	Resistant	Resistant to 300 mg/kg of artemisinin for 6 days	<i>Pcubp1</i> V2728F; <i>pcap2-mu</i> I568T	(Afonso <i>et al.</i> 2006a; Hunt <i>et al.</i> 2007; Hunt <i>et al.</i> 2010); (see chapter 4; Henriques <i>et al.</i> , 2013)
AS-ATN	Increasing doses of artesunate (±4 months)	Resistant	Resistant	Resistant to 60 mg/kg of artesunate for 6 days	<i>Pcubp1</i> V2697F; <i>pf26S-protSU</i> E738K	(Afonso <i>et al.</i> 2006a; Hunt <i>et al.</i> 2007; Hunt <i>et al.</i> 2010); (Rodrigues <i>et al.</i> , in preparation)



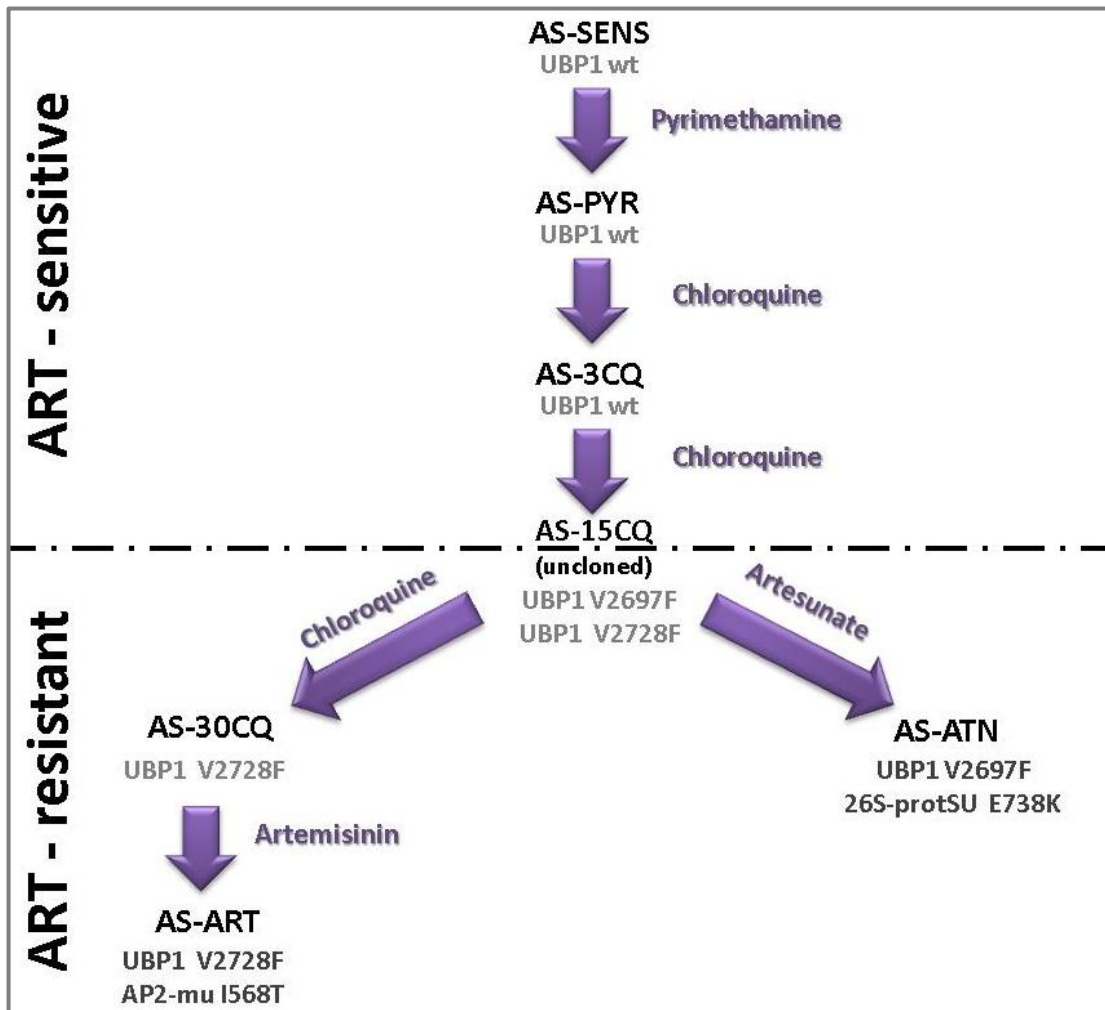

**Figure 1.4.** ART phenotypes and *ubp-1*, *ap2-mu* and *26S-protSU* genotypes in the *Plasmodium chabaudi* (AS lineage). Parasites were selected by passage in presence of drugs (pyrimethamine, CQ, artesunate or ART). The appearance of mutations in the *pcubp-1* gene is coincident with the evolution of ART-resistance phenotype during CQ selection. The AS-ART clone has a higher degree of resistance to ART relative to its progenitor, AS-30CQ [see Chapter 4 (Henriques *et al.* 2013)].

Research performed in the laboratories of Pedro Cravo and Paul Hunt have determined the genetic basis of drug resistance in some of the drug resistant AS clones, using advanced technology like Linkage Group Selection (LGS) and Solexa (second generation sequencing technology). LGS allows the identification of areas of the whole genome associated with drug resistant phenotypes, using the uncloned, recombinant progeny of genetic crosses (Culleton *et al.* 2005) and Solexa permits the rapid and accurate sequencing of whole parasite genomes and thus the identification of any mutation occurring within drug resistant clones by comparison with genetic related clones lacking the phenotype of

interest (Bentley 2006). These studies lead to the identification of three genes (Figure 1.2) that could potentially mediate ART resistance: a *de-ubiquitinating enzyme (ubp1)* (Hunt *et al.* 2007; Hunt *et al.* 2010), a gene encoding the mu ( $\mu$ ) chain of the AP2 adaptor protein complex (*ap2-mu*) (Henriques *et al.* 2013), and the 26S Proteasome regulatory subunit (*26S-protSU*) (Rodrigues *et al.*, in preparation). However, the importance of the above mentioned markers in modulating susceptibility to the ART derivatives in the human malaria parasite has not yet been assessed.

This thesis sets out to test the hypothesis that the three loci that mediate ART resistance in experimentally selected in *P. chabaudi* will similarly modify ART response in natural parasite populations of *P. falciparum*. To test this hypothesis, I will examine field isolates from Rwanda, Democratic Republic of São Tomé & Príncipe (São Tomé) Brasil and Burkina Faso which were freshly collected and tested *in vitro* for their response to ART derivatives and other antimalarial drugs. I will also evaluate pre- and post-treatment samples from two *in vivo* ACT trials, one carried out in Burkina Faso and the other one in Kenya. In these samples I will investigate the association between the presence of mutations in the *pfubp1*, *pfap2-mu* and *pf26S-protSU* genes and the *in vitro* responses to ART derivatives. Additionally, I will also investigate the association between polymorphisms on these genes with various measured endpoints in the two trials that might indicate a drug resistant parasite phenotype. If any such associations are found, a further aim will be to assess the functional basis of the mutation on the resulting protein, using molecular and biochemical techniques in an *in vitro* *P. falciparum* parasite model, and attempt to strengthen the evidence of a causal association with drug resistance.

# Chapter 2

---

**AIMS**

## Chapter 2 - Aims

The main objective of this project is to identify and characterize the genetic determinants responsible for the artemisinin resistant phenotype observed in a lineage of *P. chabaudi* drug-pressured parasites and evaluate the importance of these newly described genes in natural parasite populations of *P. falciparum*.

The specific objectives are as follows:

**Chapter 4:** To genetically identify and characterize a *P. chabaudi* parasite that presents a high level of artemisinin resistance. To explore the genetic variability of the ap2-mu gene (identified as the genetic determinant responsible for the artemisinin resistant phenotype in *P. chabaudi*) and its association with *in vitro* *P. falciparum* responses against artemisinins.

**Chapter 5:** To identify polymorphisms in *pfubp-1* and *pfap2-mu* and investigate potential associations between the identified polymorphisms and treatment outcomes using pre- and post-treatment samples from an *in vivo* ACT clinical trial conducted in Kenya.

**Chapter 6:** To identify polymorphisms in *pfubp-1*, *pfap2-mu* and pf26S-protSU genes and investigate the association between the polymorphism and *in vitro* response profiles to ART and other antimalarial drugs.

**Chapter 7:** To characterize the role of *pfap2-mu* variants in mediating the *in vitro* antimalarial drug response of *P. falciparum* by generating transgenic parasites.

**Chapter 8:** To determine temporal and spatial expression patterns of AP2-mu protein during the *P. falciparum* life cycle.

# Chapter 3

---

**MATERIAL AND METHODS**

## Chapter 3 – Materials and Methods

### 3.1. *PLASMODIUM FALCIPARUM* ISOLATES

In this thesis it was intended to investigate the genetic variation and possible contribution of mutations in the *P. falciparum* *ubp-1*, *ap2-mu* and *26S-protSU* genes to artemisinin resistance in natural infections. We investigate a collection of isolates of *P. falciparum* from Rwanda, the Democratic Republic of São Tomé & Príncipe (São Tomé), Brazil, Kenya and Burkina-Faso, as described below:

- Rwanda, São Tomé and Brazil

In **chapter 4** 180 isolates of *P. falciparum* that were previously collected and tested *in vitro* for their response to several artemisinin derivatives were analyzed. Blood samples were collected in Rwanda during November and December 2003 (Tinto *et al.* 2006), in Sao Tomé during February 2004 (Ferreira *et al.* 2007) and in Brazil during September 2005 (Ferreira *et al.* 2008).

São Tomé and Brazil isolates were tested for their *in vitro* susceptibility to different antimalarial drugs using a modified version of the standard WHO MarkIII micro-test (WHO 2001b). The *in vitro* drug sensitivity of Rwanda isolates was assessed using the classical isotopic microtest technique (Desjardins *et al.* 1979).

A set of 74 isolates from Rwanda were characterized for their *in vitro* susceptibility to dihydroartemisinin. The isolates from São Tomé were characterized for their *in vitro* susceptibility to artesunate (42 isolates) and artemether (51 isolates) and 56 isolates from Brazil were characterized for the *in vitro* susceptibility to artesunate and artemether.

- Mbita - Kenya

In **Chapter 5** 278 *P. falciparum* isolates, from one ACT clinical trial conducted in Kenya, were investigated. The participants were enrolled between April and June 2009 at the International Centre for Insect Physiology and Ecology - St. Judes Clinic, Mbita, Kenya. 300

children between 6 months and 15 years old, diagnosed with uncomplicated *P. falciparum* malaria mono-infection were enrolled and randomized to receive either artemether-lumefantrine (AL, n=156) or dihydroartemisinin-piperaquine (DHA-PIP, n=144). Treatment efficacy was assessed during a period of 42 day follow-up (Sawa *et al.* 2013).

- Bobo-Dioulasso - -Burkina Faso

*P. falciparum* isolates used in **Chapter 6** were collected from patients during a treatment trial in Burkina Faso. The clinical trial was carried out in three different periods (from December 2008 to February 2009, from July 2009 to March 2010 and from July to December 2010) at the Dafra Medical Centre, Bobo-Dioulasso. Participants who were at least 6 months of age and under 15 years old with uncomplicated *P. falciparum* malaria were enrolled in the study. 440 participants were randomly assigned to receive AL or amodiaquine-artesunate (ASAQ). Treatment efficacy was assessed during a period of 42 day follow-up. The isolates from this trial were tested *in vitro* (classical isotopic microtest technique) for their response to dihydroartemisinin, quinine, chloroquine, lumefantrine, piperaquine and monodesethylamodiaquine (Tinto *et al.* 2014).

### 3.2. DNA EXTRACTION

In **Chapter 4, 5 and 6**, molecular analysis was performed from blood samples collected on filter paper. DNA was extracted according to the method described by Plowe and co-workers (Plowe *et al.* 1995). Briefly, circular punches of 6mm diameter were taken from individual dried filter paper blood spots, using a sterile hole punch. Each filter paper punch was incubated with 1 mL of 0.5 % saponin solution in 1X phosphate buffered saline (PBS) overnight at 37 °C. Afterwards, the samples were centrifuged briefly, saponin and debris were removed and the pellets washed twice in PBS. The samples were then suspended in 6 % Chelex®100 resin in nuclease-free water and heat-sealed in deep 96-well plates. The samples were incubated in boiling water for 25 - 30 minutes to elute the DNA and then centrifuged to remove resin. After the centrifugation approximately 100 µl of supernatant containing DNA was transferred into a new 96-well plate and stored at -20 °C.

### 3.3. MOLECULAR ANALYSIS OF DRUG-RESISTANCE ASSOCIATED GENES

#### 3.6.1. PRIMER DESIGN

The *P. chabaudi chabaudi* genes previously proposed as putative modulators of drug resistance were the following: a gene encoding a deubiquitinating enzyme (*ubp1*), a gene encoding the mu ( $\mu$ ) chain of the AP2 adaptor protein complex (*ap2-mu*), and the 26S proteasome regulatory subunit gene (*26S-protSU*). The DNA sequences of these genes were available online at the PlasmoDB genome database (<http://plasmodb.org/plasmo/>) with the following accession numbers: PCHAS\_020720, PCHAS\_143590 and PCHAS\_133430, respectively. In order to obtain the *P. falciparum* orthologues of the genes we used the genetic synteny maps provided by PlasmoDB. The table 3.1 shows summarised information extracted from the PlasmoDB database regarding the candidate genes.

**Table 3.1.** Identification number (gene ID) in *P. chabaudi* (Pc) and in *P. falciparum* (Pf), gene length in Pf, full name, abbreviation and brief summary of the biological process of the investigated candidate genes.

Gene ID in Pc	Gene ID in Pf	Gene length in Pf	Annotation	Abbreviation	Biological process
PCHAS_020720	PF3D7_0104300 (PFA0220w)	10962 bp	ubiquitin-specific protease 1	<i>ubp1</i>	ubiquitin-dependent protein catabolic process
PCHAS_143590	PF3D7_1218300 (PFL0885w)	1866 bp	adaptor protein subunit	<i>ap2-mu</i>	Vesicle-mediated transport
PCHAS_133430	PF3D7_1466300 (PF14_0632)	3775 bp	26S proteasome subunit	<i>26S-protSU</i>	Ubiquitin-dependent protein catabolic process

Individual gene sequences of *P. falciparum* orthologues were retrieved from the synteny maps and used as templates for designing primers to amplify each open reading frame using an overlapping PCR fragment strategy.

Primers were manually designed for each of the genes, according to the following parameters: avoidance of the formation of self and hetero-dimers, hairpins and self complementarity, appropriate primer length and melting temperature. These properties were verified using primer design software entitled Oligonucleotide Properties Calculator: (<http://www.basic.northwestern.edu/biotools/oligocalc.html>).

Several primers were designed and used in order to amplify the complete *pfap2-mu* and *pf26S-protSU* genes and one partial sequences of the *pfubp1* gene; a 304 bp region



encompassing amino acid codons 1463 – 1563 (fragment 1). Primers producing positive results are shown in Table 3.2. These primers were then used in PCR amplifications, as described below.

**Table 3.2.** Primer sequences, PCR product sizes and annealing temperatures for 1<sup>st</sup> and 2<sup>nd</sup> amplification used for the PCR amplifications of the *pfubp1*, *pfap2-mu* and *pf26S-protSU* genes.

Gene	Fragment	1 <sup>st</sup> amplification primers (5' to 3')	Size <sup>a</sup>	AT <sup>b</sup>	2 <sup>nd</sup> amplification primers (5' to 3')	Size	AT
<i>Pfubp1</i>	1	Fw - CGCCCGTACTATGAAGAAGATC Rev - GGCTTTTACCTGAACTGTTCCAGG	484 bp	52 °C	Fw - CGTAAACAGAATATTCAGGATTGC Rev - CTAGCCCTTTATTATCATTATCG	304 bp	57 °C
	1				Fw - GTTAACACGATTAGCGTCATTTG Rev - GTCCTATTATGTATATGTGGATC	578 bp	53 °C
<i>pfap2-mu</i>	2	Fw - AAGACTGTCAAATGTAAGACCC Rev - CTCATGTAACAAAAAGTGAGG	2247 bp	50 °C	Fw - GATATCCACAAACATTAGAAGTG Rev - CCATCTGGTGGTGTGAAGG	841 bp	52 °C
	3				Fw - GCATATTCATCATTGTGTTACC Rev - ACACCCGATTGAACTATTTATAC	753 bp	53 °C
	1	Fw - CCGCCAGTGGTGAATAGC Rev - GTCTAGCATCTAAAGCAACACC	597bp	55 °C			
<i>pf26S-protSU</i>	2	Fw - GTTGATGAAATGATAGATGTGTGC Rev - GCCATCATTTATTGCCTTATCATC	690 bp	52 °C			
	3	Fw - GATAATCTAACAAATGATGAACC Rev - CGTATTTTCATCATTACTATCTCC	744 bp	52 °C			
	4	Fw - GCAAATTATAACACCAATGACAAG Rev - CCTGCGCTTACTATAGCACC	875 bp	55 °C			
	5	Fw - CGAATGAACACTGTAATCAAAC Rev - ACAGGGATTTTTCATATCGACC	842 bp	55 °C			
	6	Fw - GCCAAAAGTAAAAGTGGAGCC Rev - GTGGTGCCTCTTTTTAGACG	494 bp	55 °C			

<sup>a</sup>Size – PCR product size; <sup>b</sup>AT - Annealing temperature.

### 3.6.2. PCR

Genotyping of *P. falciparum* infections was performed with nested PCR-based methods targeting the different candidate genes *pfap2-mu* (Chapter 4, 5 and 6), *pfubp-1* (Chapter 5 and Chapter 6) and *pf26Sps* (Chapter 6). Each PCR was performed in a total volume of 25 µL with the following reaction mixture: 0.2 µM of each primer, 4.0 mM MgCl<sub>2</sub>, 0.4 µM deoxynucleotides (dNTPs) and 1 U Bioline Taq polymerase (Bioline, UK). Extracted DNA (5 µL) was added to each first round PCR mixture. One microliter of the first round product was then used as a template in a 25 µL nested amplification. The thermal cycle program for each 1<sup>st</sup> amplification was 94 °C for 3 min, and 30 cycles of 94 °C for 30 sec, annealing

temperature for 30 sec and 68 °C for 1 min with a final extension of 68 °C for 15 min. The second round of PCR consisted of one initial denaturation hold at 94 °C for 3 min, followed by 40 cycles of 94 °C for 30 sec, annealing temperature for 30 sec and 68 °C for 45 sec with a final extension of 68 °C for 10 min. Annealing temperatures for the 1st and 2nd amplifications are described in Table 3.2. DNA sample extracted from parasite line 3D7 was used as positive control. PCR products were analysed by ethidium bromide-stained agarose 2 % gel electrophoresis.

### 3.6.3. SEQUENCING OF PCR PRODUCTS

The PCR-amplified products were purified with Exonuclease I (ExoI) and Thermosensitive Alkaline Phosphatase (AP) enzymes (Fermentas, UK) in order to eliminate non-incorporated dNTPs and primers. The enzymatic purification was carried out in a final volume of 10 µL containing 5 µL of the PCR product, 3 units ExoI, 1 U AP and 1X AP reaction buffer, which were incubated for 60 min at 37 °C followed by 15 min at 72 °C for enzyme denaturation.

The cycle sequencing reactions were carried out using 1 µL ExoI/AP purified PCR amplicons, 0.5 µL BigDye® Terminator v3.1 Cycle Sequencing Kit reaction mix (Applied Biosystems, UK), 0.2 µM of each PCR primer, 1.75 µL Big Dye Sequencing Buffer (Applied Biosystems, UK) in a total volume of 10 µL. Single-base extension was performed as follow: one denaturation hold at 96 °C for 1 min followed by 25 cycles of 96 °C for 30 s, 50 °C for 15 sec, and 60 °C for 4 min.

The sequenced reaction fragments were purified using ethanol/sodium acetate precipitation method, where 3 µL 3 NaOAc (pH 4.6), 62.5 µL 100 % ethanol and 24.5 µL of nuclease free water were added to each sample. The samples were mixed by inversion and incubated at -20 °C for 25 min. After incubation, samples were centrifuged at 4 °C at 3000 g for 30 min. The supernatant was discarded by inversion and 150 µL ice cold 70 % ethanol was added to each sample. The samples were centrifuged at 4 °C at 3000 g for 10 min. The supernatant was discarded by inversion and each sample was allowed to dry at room temperature for 30 min. Finally, pellets were resuspended in 10 µL Hi-Di formamide. Samples were electrophoresed on an ABI prism 3730 Genetic Analyzer (Applied Biosystems).

#### 3.6.4. EDITING AND ASSEMBLING OF SEQUENCE PRODUCTS

Raw sequence data in the form of chromatograms from both sense and antisense primers were edited, aligned and assembled into contigs using Geneious Pro software (version 5.5.3; Biomatters) (Drummond et al., 2011), after resolving potential ambiguities by eye. Genetic polymorphisms were identified by comparing each sequence to that of the 3D7 reference genome (PlasmoDB).

#### 3.4. CONTINUOUS CULTURE OF *PLASMODIUM FALCIPARUM*

*P. falciparum in vitro* culturing was performed using previously described methods (Trager and Jensen 1976) (Chapters 7 and Chapter 8). All parasites studied were cultured in A<sup>+</sup> blood (National Health Blood & Transplant, UK) and in complete media containing RPMI 1640 growth medium (Invitrogen) supplemented, 147 µM hypoxanthine (Sigma-Aldrich), 5 g/L Albumax II (Invitrogen), 10 mM D-glucose (Sigma-Aldrich) and 2 mM L-glutamine (Sigma-Aldrich), in the case of Dd2 (Chapter 8). The complete media used for Dd2<sup>attB</sup> culturing (Chapter 7) was further supplemented with 2.5 % (v/v) human AB serum (Sigma-Aldrich) and 5 nM WR99210 (a kind gift from Jacobus Pharmaceuticals, New Jersey, USA). The parasites were kept at a 2 % haematocrit and inside of an 5 % CO<sub>2</sub> at 37 °C. The culture medium was changed every 48 hours and the parasites were sub-cultured when parasitaemia was too high. Parasitaemia was determined by microscopy examination of Giemsa (Sigma-Aldrich) stained thin films prepared from the cultured material at regular intervals. Parasite cultures were synchronized at the ring stage using sequential D-sorbitol (Sigma-Aldrich) lysis treatment (Lambros and Vanderberg 1979) and were allowed to grow for one cycle after the last treatment and then used for transfection or *in vitro* susceptibility testing.

#### 3.5. CLONING METHODS

##### 3.6.1. PCR AMPLIFICATION OF DNA

The PCR reactions were performed with Phusion<sup>®</sup> high-fidelity DNA polymerase (New England Biolabs). The reactions were carried out in a volume of 50 µl, containing 0.4 mM

dNTP mix (dATP, dTTP, dCTP, dGTP), 0.1 pmol/ $\mu$ l of each primer, 1  $\mu$ l of DNA template, 10  $\mu$ l of 5X concentrated Phusion HF buffer, 1 mM MgCl<sub>2</sub> and 2 units of DNA polymerase. DNA amplifications were performed using the following conditions: Initial denaturation (98 °C, 30 sec), 35 cycles of denaturation (98 °C, 10 sec), annealing (56 °C, 30 sec) and extension (68 °C, 1 min 30 sec), followed by a final extension (68 °C, 10 min). The yield of PCR products and correct sizes were checked by electrophoresis.

### 3.6.2. RESTRICTION/LIGATION CLONING

Digestion of the PCR products and plasmids were carried out using appropriated restriction enzymes (New England BioLabs, UK) by standard techniques. The PCR products were analysed by agarose electrophoresis, and were further purified using a Qiaquick Gel Extraction kit (Qiagen, UK). Ligations were carried out using T4 DNA Ligase (New England BioLabs, UK) and were incubated 2 h at room temperature and heat inactivated (at 65 °C for 10 min) prior to transformation.

### 3.6.3. TRANSFORMATION INTO COMPETENT CELLS

The plasmid DNA was transformed into 100  $\mu$ l of XL10-Gold ultracompetent cells (Agilent Technologies, UK) that were previously incubated for 10 min on ice with 4  $\mu$ l of  $\beta$ -mercaptoethanol (provided with the XL10-Gold ultracompetent cells kit). The mixture was incubated on ice for 30 min and after that time, the heat shock was performed as followed: 42 °C for 30 sec followed by 2 min on ice. Later, 0.9 ml of SOC medium (Invitrogen, UK) without antibiotics was added, to allow recovery of the cells. Cells were then incubated for 1 hour at 37 °C. 100  $\mu$ l of cell suspension was plated on the LB agar supplemented with 50  $\mu$ g/ml of carbenicillin (Sigma-Aldrich) and incubated at 37 °C overnight. Only XL10-Gold cells containing the plasmids should be able to grow in the presence of carbenicillin. The following day, single colonies were picked from the plates and grown overnight up in polypropylene tubes containing 5 ml LB media and carbenicillin at 37 °C.

### 3.6.4. PURIFICATION AND IDENTIFICATION OF RECOMBINANT DNA

The cells transformed with required DNA constructs were used to isolate plasmid-DNA using QIAprep Spin Miniprep kit (Qiagen, UK). The presence of the correct DNA insert in the plasmid was confirmed by restriction digestion analysis and by sequencing. Once the correct sequences of the inserts and the correct integration of the *P. falciparum* DNA into the plasmids was confirmed, the plasmid DNA copy number was amplified using the CompactPrep Plasmid Maxi kit (Qiagen). 500 ml LB with carbenicillin was inoculated with the XL10-Gold cell colony containing the correct plasmid and incubated overnight at 37 °C for each of the plasmids. The plasmid DNA was then isolated according to manufacturer's instructions for parasite transfections. The concentration and purity of preparation was confirmed on the 0.8 % agarose gel supplemented with ethidium bromide.

## 3.6.GENERATION OF *P. FALCIPARUM* TRANSFECTION CONSTRUCTS

### 3.7.1. SITE-SPECIFIC INTEGRATION USING THE MYCOBACTERIOPHAGE BXB1 INTEGRASE SYSTEM

Overexpression of the wild-type and mutant (160Asn) *pfap2-mu* gene in *P. falciparum* was performed using the bxb1 integrase system, developed by Nkrumah et al. (Nkrumah et al. 2006) (Chapter 7). This system allows the efficient and site-specific integration of genetic information into *P. falciparum* genome and consists of three components. The first component is a *P. falciparum* cell line containing an *attB* site in a defined locus. In this study we have used the Dd2<sup>attB</sup> clone of *P. falciparum*. This clone harbours an *attB* site for mycobacteriophage integration in the glutaredoxin-like gene *cg6* locus of chromosome 7. This locus was chosen because the disruption of this gene does not affect the growth of the asexual blood stages (Nkrumah et al. 2006). The second component is a plasmid containing the *attP* site for recombination, the transgene and drug resistance cassette. The last component is the plasmid containing the Bxb1 integrase, which facilitates the recombination event. In a dually transfected parasite, the integrase expressed from pINT catalyzes the crossover of the plasmid containing the *attP* site with the genomic *attB* site, resulting in the integration the transgene into the genome.

In this study we have used the following plasmids: the integrase-expressing plasmid pINT, which contains a Neomycin selectable marker that confers G418 resistance; the

attP-containing plasmids pDC2-*cam-pfap2-mu-attP*, which harbors a wild-type or a mutant (160Asn) *pfap2-mu* expression cassette as well as a *bsd* (blasticidin S-deaminase) selectable marker that confers resistance to blasticidin hydrochloride (Figure 3.1).

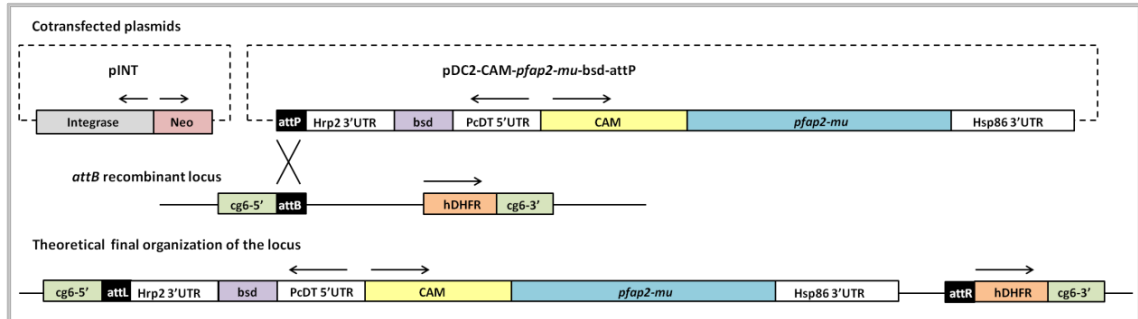

**Figure 3.1. Site specific integration of *pfap2-mu* gene (WT and 160Asn) into the *P. falciparum* Dd2<sup>attB</sup> line. (A)** Schematic diagram of the integrase-mediated *attB* x *attP* recombination approach ((Nkrumah *et al.* 2006). The top panel shows the cotransfected plasmids: plasmid pINT, carrying the integrase expression unit that catalyses the recombination, and the neomycin resistance cassette (*neo*); and the pDC2-CAM-*pfap2-mu-bsd-attP* plasmid carrying the WT or a mutant 160Asn *pfap2-mu* gene sequence under the control of the calmodulin promoter, a blasticidin resistance cassette (*bsd*) and the *attP* site. The middle panel shows the recipient *cg6-attB* recombinant locus present in Dd2<sup>attB</sup>. The *attB* x *attP* recombination generates two sites, *attL* (left) and *attR* (right). The hDHFR represent the drug selection markers for WR99210. The lower panel represents the integration of the pDC2-CAM-*pfap2-mu-bsd-attP* plasmid into the *cg6-attB* locus of Dd2<sup>attB</sup>.

To generate the pDC2-*cam-pfap2-mu-attP* (whose expression cassette is illustrated in Fig 3.1) and the pDC2-*cam-pfap2-mu*<sub>160Asn</sub>-*attP* plasmids, the open reading frames of both the wild-type and mutant (160Asn) allele of the *pfap2-mu* gene were amplified, from genomic DNA of *P. falciparum* parasite line 3D7 and from a *P. falciparum* field sample previously shown to harbour the 160Asn mutation, respectively (Henriques *et al.* 2014b). The full gene was amplified by PCR with the following primers (start and stop codons of the gene are in red font):

forward primer 5'- CGTACTAGTATGATCGATGCGCTGTACAT -3' (*SpeI* site underlined)

reverse primer 5'- ATGCCTCGAGCTATTTATACTGGTAGATGCC -3' (*XhoI* site underlined)

The *pfap2-mu* amplicons were cloned using *AvrII/XhoI* sites (New England BioLabs, UK) and integrated between the *calmodulin* (Pf14\_0323) promoter and the *hsp86* (PF07\_0030) 3' UTR in a pDC2 vector (Lee *et al.* 2008) with the *bsd* selectable marker.

### 3.7.2. CONSTRUCTION OF *PFAP2-MU*-GFP FUSION CONSTRUCTS

To localize pfAP2-mu in the parasite, we have engineered *P. falciparum* Dd2 parasites stably expressing GFP fused to *pfap2-mu* gene under the control of its endogenous promoter, using a single-cross-over homologous recombination strategy (Chapter 8). A region encoding the 3' end (leaving out the stop codon) of *pfap2-mu* gene was PCR amplified from 3D7 genomic DNA using the following primers:

forward primer 5'-CGTACTGCAGGATATCCACAAACATTAGAAG-3' (*Pst*I site underlined)

reverse primer 5'-CGTAGCGGCCGCATTATTA TACTGGTAGATGCCCC -3' (*Not*I site underlined)

The 1508 bp *pfap2-mu* amplicon was digested with *Pst*I and a *Not*I (New England Biolabs) and cloned into similarly digested pH-GFP transfection plasmid (Witmer *et al.* 2012) before the GFP coding sequence, to generate pH-*pfap2-mu*-GFP vector (Figure 3.2).

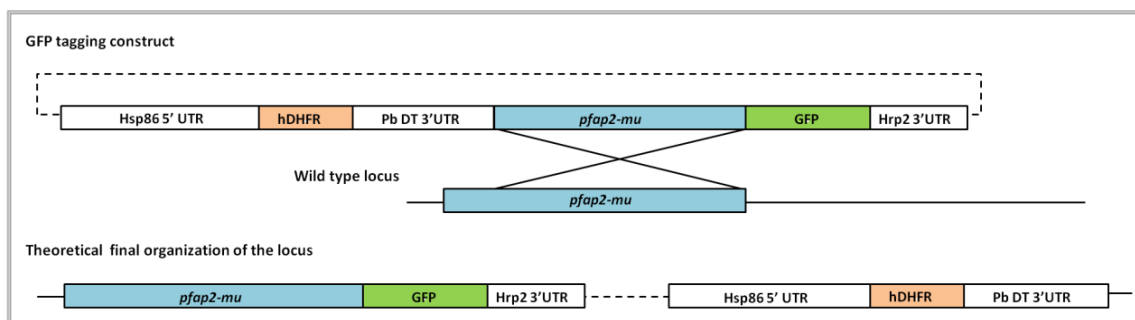

**Figure 3.2. GFP tagging of *pfap2-mu*.** Schematic representation of the single-cross-over homologous recombination strategy showing the the pH-*pfap2-mu*-GFP plasmid containing ~1500 bp of the 3' end coding sequence of *pfap2-mu* fused in frame with the GFP sequence (top panel); the wild type *pfap2-mu* locus (middle panel); and the recombined *pfap2-mu*-GFP locus resulting from integration of the GFP-tag construct (lower panel). Transcription termination and polyadenylation of the *pfap2-mu*-GFP transgene are ensured by the presence of the Hrp2-3' untranslated region (UTR) of *P. falciparum* histidine-rich protein 2. The human dihydrofolate reductase (hDHFR) represents the positive drug selection marker for WR99210.

The resulted plasmids were verified by sequence analysis and DNA for transfection was purified using the Qiagen CompactPrep Plasmid Maxi Kit (Qiagen, UK).

### 3.7. TRANSFECTION EXPERIMENTS

Transfections of *P. falciparum* were carried out as described by Adjalley and colleagues (Adjalley *et al.* 2010) with slightly modifications. Briefly, 250  $\mu$ l of infected red blood cells, from a synchronized 6-9 % parasitaemia ring-stage cultures was added to 400  $\mu$ l of the

plasmids preparation. To achieve the integrase mediated recombination (**Chapter 7**), 50 µg of the plasmid containing the attP site together with the *pfap2-mu* gene (WT or the 160Asn copy) and 50 µg of the pINT plasmid containing the integrase expression unit that catalyses the recombination, and the neomycin resistance cassette (each in 25 µl TE buffer) were resuspended in cytomix [120 mM KCl, 0.15 mM CaCl<sub>2</sub>, 2 mM EGTA (pH 7.6), 5 mM MgCl<sub>2</sub>, 10 mM K<sub>2</sub>HPO<sub>4</sub>/KH<sub>2</sub>PO<sub>4</sub> (pH 7.6) and 25 mM HEPES (pH 7.6)]. In the GFP tagging experiment (**Chapter 8**) 50 µg of the vector containing the *pfap2-mu*-GFP fusion construct was resuspended in cytomix.

Parasites were transfected by electroporation (voltage of 0.31 kV, capacitance of 950 µF and infinite resistance; Bio-Rad Gene Pulser II, Bio-Rad, UK), using Bio-Rad Gene Pulser electroporation cuvettes (0.2 cm gap) and then immediately transferred to culture flasks containing 10 ml of complete media and 500 µl of fresh red blood cells. One to four hours after electroporation the culture medium was replaced with fresh complete media. Transfectants were allowed to recover in drug-free medium of 24 h and then were selected with the appropriated drug. For the site specific integration (**Chapter 7**) the parasites were selected with 2.5 µg/ml blasticidin (Sigma-Aldrich) and 125 µg/ml of G418 (Invitrogen, Life Technologies). Since the integrase-mediated recombination is thought to be a rapid event, the drug pressure with G418 (that selects the pINT plasmid) was only applied for 6 days. Alternatively, the parasites were selected with 5 nM WR99210 (a kind gift from Jacobus Pharmaceuticals, New Jersey, USA) (**Chapter 8**).

The medium was changed daily for the first 6 days, and then every other day with fresh medium containing the blasticidin or WR99210 selection agents. Cultures were diluted 3:5 weekly (by the addition of 30 % fresh blood cells) and monitored by Giemsa staining every 4-5 days for appearance of the transfected parasites. Once the transfected parasites reached a parasitemia of approximately 5 % rings they were frozen, and genomic DNA was prepared for analysis to determine if the plasmid had been correctly integrated into the parasite genome.

### 3.8. ISOLATION OF GENOMIC DNA FROM *P. FALCIPARUM*

Genomic DNA was harvested from schizont stages parasites at ≥ 5 % parasitaemia (**Chapter 7** and **Chapter 8**). The cells were lysed with saponin and after centrifugation; the



pellet was resuspended in lysis buffer (500 mM Na Acetate pH 5.2, 100 mM NaCl, 1 mM EDTA, 3 % SDS). DNA was isolated with phenol/chloroform extraction at room temperature and ethanol precipitation. Finally the DNA was resuspended in TE buffer.

### 3.9. GENOTYPE ANALYSIS OF TRANSGENIC PARASITES BY PCR

Genotype analysis of transformed parasites was performed by PCR in **Chapter 7** and **Chapter 8**. For the transgenic parasites obtained in **Chapter 7**, correct integration was verified by PCR using the P1/P2 primer pair (Table 3.3) and the presence of the 160Asn mutation in the Dd2<sup>attB</sup>::160Asn-*pfap2-mu* line was confirmed by sequencing using primers P2/P3 (Table 3.4). Integration of the GFP-tag construct in the *pfap2-mu* locus (**Chapter 8**) was confirmed by a diagnostic PCR using primer pair P5/P6 (Table 3.3).

**Table 3.3.** Primer sequences used in vector integration confirmation by PCR

Primer	Sequence (5' – 3')	Description
P1	CCAGGATCCAAAAGAAGGAGGAGG	Confirming integration of the bsd cassette into the <i>attB</i> recombinant locus (Forward)
P2	ATGCATGCCAAGCCTTTGTCTCAAG	Confirming integration of the bsd cassette into the <i>attB</i> recombinant locus (Reverse)
P3	GATATCCACAAACATTAGAAGTG	Confirming the presence of the 160Asn mutation (Forward)
P4	CCATCTGGTGGTGTGAAGG	Confirming the presence of the 160Asn mutation (Reverse)
P5	CCGTATTAACAAGAAGCAATTC	Confirming integration of the GFP-tag construct in the <i>pfap2-mu</i> locus (Forward)
P6	CCCTCTCCACTGACAGAAAAT	Confirming integration of the GFP-tag construct in the <i>pfap2-mu</i> locus (Reverse)

### 3.10. CONFIRMATION OF INTEGRATION BY SOUTHERN BLOT ANALYSIS

For Southern blot analysis the *pfap2-mu*-GFP transgenic parasites (**Chapter 8**), genomic DNA was digested with *Clal/NcoI* (New England Biolabs, UK) and the digested DNA was separated on a 0.8 % agarose gel. The gel was depurinated in 0.25 M HCL and denatured in 0.4 M NaOH before transferred overnight to a BrightStar®-Plus positively charged nylon

membrane (Ambicon, UK) by gravitational flow. The DNA was UV cross-linked to the membrane.

The integrants were screened using probes against the 5'-end of the *pfap2-mu* gene. The *pfap2-mu* probe was PCR amplified using the following primers:

Forward primer 5'- CGGGCAACTTCTGATACAAAG -3'

Reverse primer 5'- GTCCTATTATGTATATGTGGATC -3'

The PCR was performed with the following conditions: 15 sec denaturation at 98 °C, 30 sec annealing at 55 °C, and elongation 45 min at 68 °C; the cycle was repeated 35 times. The PCR product was purified using a QIAquick PCR purification kit (Qiagen, UK).

The probe was <sup>32</sup>P-labelled by random priming using the Redoprime-II random prime labelling system (GE Healthcare). The target DNA was denatured for 5 min at 96 °C and cooled on ice for 5 min. Denatured DNA was added to the labelling reaction mix (Klenow fragments, dNTPs, random hexamers), then <sup>32</sup>P dATP (3000 Ci/mM) was added and the mixture was incubated for 15 min at 37 °C and the reaction was stopped using TE buffer. Unincorporated nucleotides were removed using Illustra Microspin G-25 columns (GE Healthcare, UK) and hybridization was performed overnight at 60 °C, in a solution containing 6X SSC buffer, 2X Denhardt's, 0.1 % SDS, 100 µg/ml of sheared herring DNA. Membranes were washed two times at 60 °C, with 2X SSC buffer and exposed to an Amersham Hyperfilm MP (GE Healthcare, UK) at -80 °C.

### 3.11. QUANTITATIVE RT-PCR ON MRNA SAMPLES OF *P. FALCIPARUM*

In order to verify the constitutive blood-stage expression of the introduced transgenes we performed quantitative RT-PCR analysis of cultures of the parental (Dd2<sup>attB</sup>) and transfected Dd2<sup>attB</sup>::WT-*pfap2-mu* and Dd2<sup>attB</sup>::160Asn-*pfap2-mu* parasite lines (Chapter 7).

For total RNA isolation, parasitized red cells (from ring stage and late stage samples) were rapidly lysed in TRI Reagent (Sigma-Aldrich, UK) and then stored at -80 °C prior to RNA extraction, which followed the manufacturer's protocol as previously described (Schwank *et al.* 2010). Briefly, the TRI Reagent lysates were thawed at 37 °C, 0.4 ml of chloroform (Sigma-Aldrich, UK) was added, and the mixture was vigorously mixed and incubated for 15 min at room temperature before centrifugation (12,000 xg, for 15 min at 4 °C). The

aqueous phase was precipitated with 0.5 ml of isopropanol (Sigma-Aldrich, UK), incubated for 10 min at room temperature and centrifuged (12,000 xg, for 10 min at 4 °C) to allow RNA precipitation, and the pellet washed with 75 % ethanol (Sigma-Aldrich, UK). The samples were stored at 4 °C overnight and then centrifuged at 12,000 xg, for 10 min at 4 °C. The ethanol was removed and the RNA pellet was air-dried, before being resuspended in 20 µl of nuclease free water (Promega, UK).

Extracted RNA was treated with RQ1 RNase-free DNase (Promega, UK) and reverse transcribed using gene specific primers (*pfap2-mu*: Q2 and *pfpgmet*: Q4; Table 3.4) and the GoScript reverse transcriptase Kit (Promega), as described by the manufacturer. Each DNase treated preparation was then split in two. In the control tubes the reverse transcriptase was replaced with water (DNA contamination control).

**Table 3.4.** Primer sequences used in quantitative RT-PCR on *P. falciparum* mRNA

Primer	Sequence (5' – 3')	Description
Q1	GGAAAGGTAACCTTAAAATGTC	<i>pfap2-mu</i> amplification (Forward)
Q2	GTTACTACCGGCGAGAATATT	<i>pfap2-mu</i> amplification (Reverse) and cDNA synthesis
Q3	TGAAAGCAGCGTAGCTCAGA	tRNA amplification (Forward)
Q4	CGCGTGGTTTCGATCCACG	tRNA amplification (Reverse) and cDNA synthesis

Quantitative RT-PCR (qRT-PCR) was performed using QuantiTect SYBR Green PCR Kit (Qiagen) in a Rotor-Gene RG3000 machine (Corbett Research). Transcripts of the *pfap2-mu* gene were amplified using the Q1/Q2 primer pair (Table 3.4, above) and the *Plasmodium* tRNA methionine (PgMET) gene was used as a reference source of RNA. Previously published primer sequences Q3/Q4 (Table 3.5) were used to amplify the *pgmet* gene as described (Beshir, Hallett, *et al.* 2010). Reactions were carried out in 25 µl volumes using QuantiTect SYBR Green PCR master mix according to the manufacturer's guidelines. The PCR cycles used were 95 °C for 6 minutes followed by 40 cycles of 95 °C for 15 sec and 60°C for 1 min, for all reactions. Each parasite RNA sample was tested in triplicate in each experiment. Relative expression of *pfap2-mu* was calculated from the average threshold cycle (CT) values from two experiments, normalized to *pgmet*, using the  $\Delta\Delta^{Ct}$  method, where the parental line was used as the comparator.

### 3.12. DRUG SUSCEPTIBILITY ASSAYS

We analysed the susceptibility of the transgenic *P. falciparum* parasites expressing an extra copy of either the wild-type (WT) *pfap2-mu* gene or the 160Asn form (Chapter 7) to several antimalarial drugs using the following drug susceptibility assays.

#### Standard 48 hour drug susceptibility assays

Standard 48 hour drug exposure assays were performed to determine the susceptibility of parasites to dihydroartemisinin (DHA), quinine, chloroquine, lumefantrine, mefloquine and atovaquone according to protocols using the intercalating dye PicoGreen to provide a fluorescent signal, as previously deployed in our laboratory (van Schalkwyk *et al.* 2013). The resulting  $IC_{50}^{48h}$  estimates were used as primary indicators of anti-malarial susceptibility, determined from a log-dose response analysis using the Prism v6.04 (GraphPad Software, Inc., San Diego, CA). Each assay was performed with two replicates on at least two (range 2 – 6) independent occasions for each drug. For statistical analysis best-fit estimates of the  $IC_{50}$  and their 95 % confidence intervals were obtained by nonlinear regression fitting of the sigmoidal dose response curve for each drug across all experiments, after normalisation using control well fluorescent signals. For statistical comparison of each transgenic with the parental curve and comparison between the two transgenic curves, data were first fitted independently and then globally to find a shared best-fit value for the  $IC_{50}^{48h}$ . Results were compared by a sum-of-squares *F*-test.

#### Artemisinin 6 hour pulse assays

To generate  $IC_{50}^{6h}$  estimates for artemisinin, we devised an alternative *in vitro* drug susceptibility protocol. DHA was serially diluted in complete medium (250  $\mu$ l) in microcentrifuge tubes, using the same ten concentrations generated for the standard 48 hour drug assays. 250  $\mu$ l of ring stage culture was added to each drug dilution (2 % final hematocrit and 0.5 % final parasitemia) and incubated at 37 °C for 6 hours. After the incubation time half of the culture was placed in a 96-well tissue culture plate (modified 48 hour assay) and the other half was washed three times with 1000  $\mu$ l of RPMI, to remove dihydroartemisinin, before being replenished with drug free medium and placed in the 96-well culture plate. The plate was then incubated at 37 °C for 42 hours until growth assessment using the PicoGreen detection method. As described for the standard 48 hour

assays, PicoGreen detection method generates a measure of DHA sensitivity in the form of an  $IC_{50}^{6h}$  estimate.

### Ring stage survival assays (RSA)

The RSA was performed as described by Witkowski and colleagues (Witkowski *et al.* 2013) with minor modifications. The parasite cultures were tightly synchronized across two consecutive ring stage cycles with sorbitol treatment. Late schizont stage parasites cultures were enriched using MACS separation columns (Miltenyi Biotech GmbH) and were cultured for 3 hours at 37 °C with fresh erythrocytes, and again sorbitol-treated. This early ring stage (0-3 hours) parasite preparation, at 1 % parasitaemia, 2 % haematocrit in 2 ml final volume, was then exposed for 6 hours to 700 nM of dihydroartemisinin in 0.1 % DMSO. After the 6 hour exposure the cultures were washed and resuspended in drug-free culture medium and cultured at 37 °C for a further 66 hours. Dihydroartemisinin susceptibility was then assessed microscopically on thin films by estimating the percentage of viable parasites that had developed into a new generation of trophozoites, 66 hours after dihydroartemisinin exposure, compared to parasites exposed to 0.1 % DMSO alone.

### 3.13.FLUORESCENCE MICROSCOPY

Localization of fluorescent protein-tagged *pfAP2-mu* in transfected parasites (**Chapter 8**) was analyzed through direct detection of the green fluorescence in paraformaldehyde fixed parasite samples and through immunofluorescence assays (IFA). For IFA, thin smears of parasite cultures were air dried and fixed using 100 % methanol at -20 °C for 2 minutes. The fixed cells were washed with PBS. After washing, the slides were incubated for 1 h at RT with mouse anti-GFP (1:20, Roche, UK) antibody diluted in 3% bovine serum albumin (w/v) in PBS. Cells were washed three times with PBS and incubated with IgG-specific secondary antibody coupled with Alexa Fluor® 488 (1:400, Sigma, UK) for 1 h at RT and then washed 3 times with PBS.

The smears were mounted for microscopic examination with vectashield mounting medium with 4',6-diamidini-2-phenylindole (DAPI) (Vector). Images were acquired using a Zeiss LSM510 laser scanning confocal microscope (Carl Zeiss Jena GmbH, Germany) and images were processed using Zeiss LSM Image Browser software version 4.0.0.157.

# Chapter 4

---

## ARTEMISININ RESISTANCE IN RODENT MALARIA -MUTATION IN THE AP2 ADAPTOR $\mu$ -CHAIN SUGGESTS INVOLVEMENT OF ENDOCYTOSIS AND MEMBRANE PROTEIN TRAFFICKING

**Adapted from:** Henriques G., Martinelli A., Rodrigues L., Modrzynska K., Fawcett R., Houston D.R., Borges S. T., d'Alessandro U., Tinto H., Karema C., Hunt P., Cravo P.. 2013. Artemisinin resistance in rodent malaria - mutation in the AP2 adaptor  $\mu$ -chain suggests involvement of endocytosis and membrane protein trafficking. Malar J. Apr 5 12:118



Registry

T: +44(0)20 7299 4646  
F: +44(0)20 7299 4656  
E: registry@lshtm.ac.uk

**COVER SHEET FOR EACH 'RESEARCH PAPER' INCLUDED IN A RESEARCH THESIS**

Please be aware that one cover sheet must be completed for each 'Research Paper' included in a thesis.

1. For a 'research paper' already published

1.1. Where was the work published? Malaria Journal

1.2. When was the work published? April, 2013

1.2.1. If the work was published prior to registration for your research degree, give a brief rationale for its inclusion

1.3. Was the work subject to academic peer review? yes

1.4. Have you retained the copyright for the work? Yes / No

If yes, please attach evidence of retention.

If no, or if the work is being included in its published format, please attach evidence of permission from copyright holder (publisher or other author) to include work

2. For a 'research paper' prepared for publication but not yet published

2.1. Where is the work intended to be published? .....

2.2. Please list the paper's authors in the intended authorship order

2.3. Stage of publication – Not yet submitted / Submitted / Undergoing revision from peer reviewers' comments / In press

3. For multi-authored work, give full details of your role in the research included in the paper and in the preparation of the paper. (Attach a further sheet if necessary)

I genotyped the field samples and helped writing the paper.

NAME IN FULL (Block Capitals) GISELA CRISTINA LORENÇO HENRIQUES

STUDENT ID NO: 298382

CANDIDATE'S SIGNATURE Gisela Kemp Date 27/8/2014

SUPERVISOR/SENIOR AUTHOR'S SIGNATURE (3 above) C. SUTHERLAND 27/8/2014

## Evidence of permission to include the published work in the thesis:

### 00535536 re:Re

---

**From:** ""Jess Ramos Jr" <info@biomedcentral.com>" <info@biomedcentral.com>  
**To:** Gisela.Henriques@lshtm.ac.uk  
**Date:** Wednesday - August 13, 2014 5:47 AM  
**Subject:** 00535536 re:Re  
**Attachments:** Mime.822

---

Dear Dr Henriques

Thank you for contacting BioMed Central.

The article you refer to is an open access publication. Therefore you are free to use the article for the purpose required, as long as its integrity is maintained and its original authors, citation details and publisher are identified.

For detailed information about the terms please refer to the open access license:

<http://www.biomedcentral.com/about/license>.

If you have any questions please do not hesitate to contact me.

Best wishes

Jess Ramos Jr  
Customer Services  
info@biomedcentral.com  
www.biomedcentral.com  
-----Your Question/Comment -----

Dear Sir/Madam,

I would like to request permission to include the following article that I published and authored with you:

"Henriques G, Martinelli A, Rodrigues L, Modrzynska K, Fawcett R, Houston DR, Borges ST, d'Alessandro U, Tinto H, Karema C, Hunt P, Cravo P. (2013) Artemisinin resistance in rodent malaria--mutation in the AP2 adaptor mu-chain suggests involvement of endocytosis and membrane protein trafficking. Malar J **12**: 118"

in the digital copy of my thesis which will be made publically available through LSHTM Research Online <http://researchonline.lshtm.ac.uk/> . This is our institutional repository and is non commercial and openly available to all.

Yours sincerely  
Gisela Henriques



## Abstract

Malaria, caused by *Plasmodium falciparum*, is a devastating infectious disease, whose control is hampered by the relentless evolution of drug resistance. Because artemisinin derivatives are now used in the most effective antimalarial therapies, resistance to artemisinin would be catastrophic. Indeed, studies suggest that parasites resistant to artemisinin have already appeared in natural infections. Understanding the mechanisms of resistance would help to prolong the effective lifetime of these drugs. Genetic markers of resistance are therefore required urgently. Previously, a mutation in a de-ubiquitinating enzyme was shown to confer artemisinin resistance in the rodent malaria parasite *Plasmodium chabaudi*.

Here, increased resistance to artemisinin in a related parasite is characterised and genetic variation investigated using Illumina whole-genome re-sequencing. We identify just one point mutation in a gene encoding an AP2 adaptor protein, a component of the endocytic machinery. Homology models indicate that the mutated residue interacts with a cargo recognition sequence. We investigated polymorphisms in the orthologous gene in natural infections of the human malaria parasite *Plasmodium falciparum*. One specific polymorphism was weakly correlated with *in vitro* responses to an artemisinin derivative in isolates from Rwanda.

In conclusion, whole-genome re-sequencing identified a mutation in a gene encoding an adaptor protein, suggesting that the endocytosis and trafficking of membrane proteins is modified in artemisinin-resistant rodent malaria parasites. This provides new insights into possible mechanisms of resistance to artemisinin and its derivatives. Analysis of *P. falciparum* field isolates showed a weak association between a polymorphism in this gene and *in vitro* artemisinin responses. The genotypes of this adaptor protein should be evaluated for its role in ART resistance in human infections of *P. falciparum*.

## Introduction

Without an effective vaccine, prevention and treatment of human malaria has traditionally relied on chemoprophylaxis and/or chemotherapy [1]. However, *Plasmodium falciparum* has developed resistance to nearly every anti-malarial drug introduced to date, compromising its control. Resistance arises via the selection of parasites bearing specific mutations, and is decisive in determining the effective lifetime of anti-malarial agents.

Artemisinin combination therapy (ACT) is now a widely used anti-malarial treatment. The artemisinin component is a highly effective and rapidly acting drug [2]. The understanding of its mode of action is incomplete [3,4], but independent lines of evidence from a number of laboratories suggest that its action depends upon its endoperoxide group and activation by haem or other iron sources [3]. Downstream, it may localize close to the digestive vacuole (DV) [5] and effect changes in DV morphology [6] or the distribution, endocytosis and digestion of haemoglobin [7]. Alternatively, it has been suggested that artemisinin may inhibit the  $\text{Ca}^{2+}$ -ATPase (PfATP6) [8].

Alarming, recent data indicate that resistance to artesunate, one of several artemisinin derivatives (ARTDs), is emerging in Cambodia and Thailand [9-14]. Molecular (DNA) markers of resistance are therefore required urgently. These tools will help to monitor the evolution of resistance, to establish rational treatment policies and to design drug combinations that delay the evolution of resistance. At present however, in *P. falciparum*, there are no universally accepted and validated molecular markers of artemisinin resistance in the field. Polymorphisms in PfATPase6 [15,16] or amplification of the multidrug resistance gene, *Pfmdr1* [17-19] have been investigated. However, no correlation was found between variants of these genes and *in vivo* responses to ARTDs in the first suggested cases of resistance along the Thai/Cambodian border [20,21].

Candidate gene approaches may not focus on the critical genes nor grasp the full complexity of the drug response mechanisms. Instead, analysis of genetic haplotype variation and conservation and geographic differentiation using genome-wide SNP typing of *P. falciparum* parasites from Southeast Asia (Thailand, Cambodia and Laos), where resistance to ARTDs is emerging, has identified candidate regions associated with slow parasite clearance rates after drug treatment [21], particularly in a region on chromosome 13. No specific genes in this region were identified as candidates for influencing artemisinin response.

Other experimental studies that do not prejudge the critical genes are especially informative; for example, the *in vitro* generation of mutant *P. falciparum* parasites resistant to drugs. Parasites resistant to ARTs have been generated and *mdr1* duplications identified [22], but often the phenotypes and genetic changes have tended to be unstable in the absence of drugs [23,24]. Genetic linkage analysis of the experimental *P. falciparum* Hb3 x Dd2 cross has shown that three *loci*, including *pfmdr1* and two additional *loci* (on chromosomes 12 and 13) [24] that were associated with artemisinin (ART) responses or the potential to evolve ART resistance, but neither of these parental parasites offered a distinct ART-R phenotype.

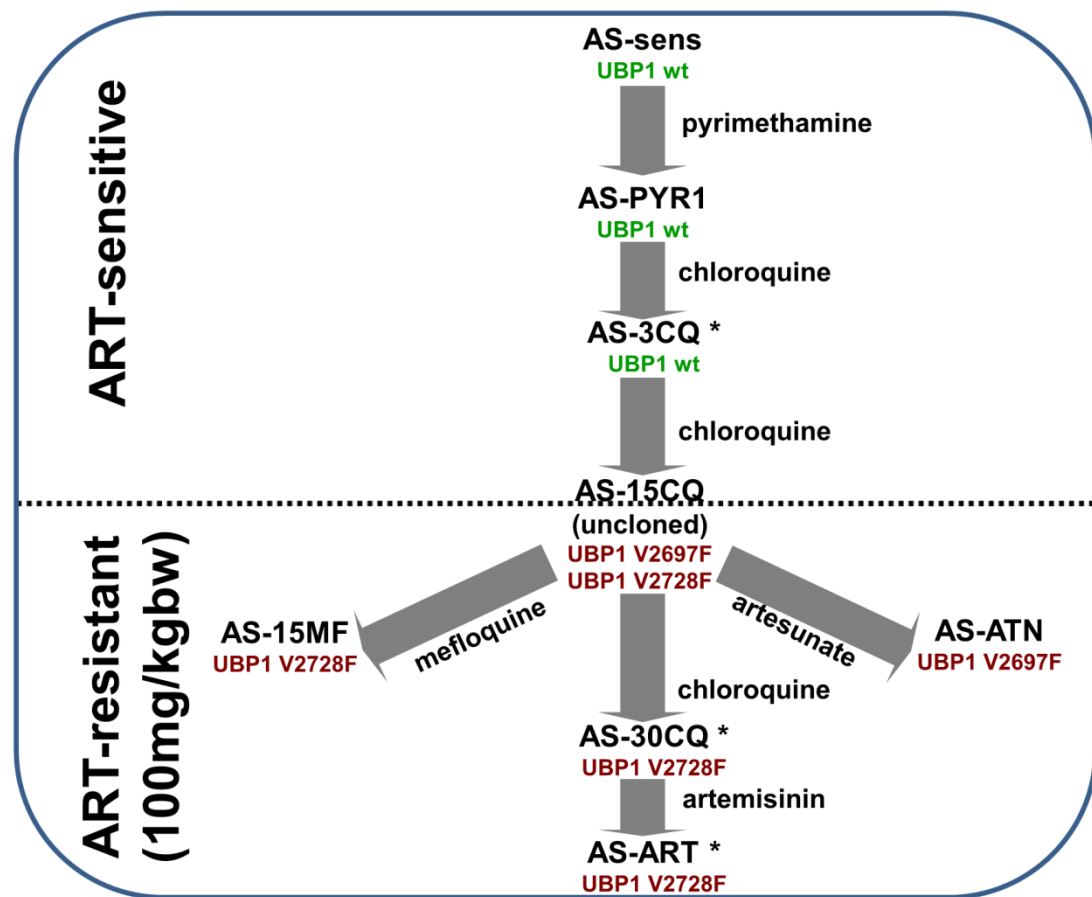

**Figure 1** The AS lineage of drug resistant parasites, featuring artemisinin (ART) phenotypes and *ubp-1* genotypes. Parasites were selected by passage in presence of drugs shown [29-33]. Artemisinin resistance (phenotype 1) appears during selection by chloroquine [25,26] and is mediated by either of two mutations in the *ubp-1* gene (PCHAS\_020720) [25,27]. AS-ART was generated during selection by artemisinin [29]. Its increased resistance to artemisinin (phenotype 2) and its genotype is the subject of the present study. \*, parasites used in the present study; wt, wild-type.

*In vivo* experimental studies using the rodent malaria *Plasmodium chabaudi* can circumvent some limitations faced by *in vitro* experimentation. A lineage (strain AS) of genetically stable mutant parasite clones that are resistant to various drugs has been generated by experimental evolution under drug selection (Figure 1). The genetic mutations conferring resistance to pyrimethamine, sulphadoxine, chloroquine, mefloquine, lumefantrine and artemisinin have been mapped using efficient genetic linkage mapping (population based genome-wide scans of selection) and Illumina whole-genome sequencing [30-33]. The identification of the critical mutations exploits four important features relevant to the present study. Firstly, the resistance phenotype appears at the same time/position in the lineage as the critical mutation. Secondly, the mutation will lie at the bottom of a 'selection valley' (genomic region selected by drug). Thirdly, these studies exploited a previously completed reference genome sequence isogenic to the progenitor parasite, AS-sens. Fourthly, the numbers of point mutations (genome-wide) fixed at each step by selection or during cloning are very small, typically 1–3 [31].

For artemisinin, a mutation in a de-ubiquitinating enzyme (V2728F *ubp1*) was proposed previously as the critical determinant of an artemisinin-resistance (ART-R) phenotype [30] in parasite AS-30CQ (Figure 1). This *ubp1* mutation has also been shown to contribute to resistance to mefloquine and lumefantrine [32] and higher doses of chloroquine [31], as well as ARTs, suggesting that *ubp1* may mediate parasite responses to multiple drugs, as does *mdr1* duplication [32].

Here, another parasite, AS-ART (Figure 1), derived from AS-30CQ after prolonged and progressive ART selection [25], is investigated. An increased ART-R phenotype is characterized and a single point mutation in its genome is defined. The 3D structures of homologues of the mutated protein are investigated for possible functional consequences. Allelic variations of the *P. falciparum* orthologue of the mutated gene are defined in a set of *P. falciparum* field samples.

## Methods

### Ethics

All animal work was conducted according to relevant national and international guidelines: in Portugal, after approval by the Ethics Committee of the Instituto de Higiene e Medicina Tropical of Lisbon, Portugal, under PARECER 2/2006 from 1 August, 2006 and in the UK, in compliance with the UK Animals (Scientific Procedures) Act 1986.

### Parasite lines, maintenance, parasite preparation and DNA extraction

All the parasite clones used in this study are members of the AS lineage (Figure 1). Three parasite clones were used: i) AS-3CQ, a parasite that is resistant to low levels of chloroquine [34]; ii) AS-30CQ, that is resistant to high levels of chloroquine [34]; and, iii) AS-ART, which was derived from AS-30CQ through multiple sub-inoculations in mice under increasing doses of artemisinin (ART) [25]. All parasites were routinely inoculated, passaged in CBA mice (four to six weeks) and cryopreserved as previously described [26]. Parasites were prepared and DNA extracted as previously described [35], ensuring that host white cells were removed by CF11 cellulose (Whatman) and Plasmodipur filters (Eurodiagnostica). DNA samples from other clones within the lineage were used to determine the earliest appearance of specific mutations within the lineage. All animal work was conducted according to relevant national and international guidelines: in Portugal, after approval by the Ethics Committee of the Instituto de Higiene e Medicina Tropical of Lisbon, Portugal, under PARECER 2/2006 from August 1st 2006 and in the UK, in compliance with the UK Animals (Scientific Procedures) Act 1986.

### *In vivo* ART drug tests

*In vivo* ART response phenotypes were assessed as follows. Four to six-week-old inbred CBA mice were divided into nine groups of three mice each. Mice in groups 1–3 were inoculated with 10exp6 parasitized red blood cells (pRBC) of AS-3CQ, AS-30CQ or AS-ART, respectively and given the diluting solvent DMSO orally (untreated controls). Treatment groups 4–6 were inoculated with 10exp6 pRBC of either AS-3CQ, AS-30CQ or AS-ART and treated with an oral daily dose of 200 mg ART kg<sup>-1</sup> mouse bodyweight, administered for a

total of three consecutive days, starting day 1 post-inoculum (pi). Treatment groups 7–9 were inoculated with  $10 \times 10^7$  pRBC of either AS-3CQ, AS-30CQ or AS-ART and treated with 200 mg ART  $\text{kg}^{-1}$  mouse bodyweight, administered for a total of five consecutive days. Individual percentage (%) parasitaemia was followed from day 4 pi onwards and up to day 15 in the case of untreated control mice. For treated mice, % parasitaemia was first assessed one day after the last day of treatment and up to day 18 pi. Results were expressed as daily average % parasitaemia  $\pm$  standard error from the three mice within each experimental group.

### Genome-wide resequencing

Clone AS-sens was previously resequenced with the Illumina® platform using 36 bp single reads [30]. Clone AS-ART was also re-sequenced using 36 bp single-end reads. Individual sequence strings (reads) from AS-sens and AS-ART were aligned against the isogenic AS reference genome assembly (AS-WTSI [36], provided by the Wellcome Trust Sanger Institute, using two different software packages: MAQ (Mapping and Assembly with Quality) [37] and SSAHA2 (Sequence Search and Alignment by Hashing Algorithm) [38]. The AS-WTSI sequence data consisted of a recently completed assembly and annotation made available during this investigation. Detection of SNPs was performed with Samtools [39] and MAQ, using default parameters, as described in Hunt *et al.* [30]. Small ( $\leq 3$  bp) indels were detected using Samtools internal algorithm only. The list of single nucleotide polymorphisms (SNPs) and small indels were further filtered by removing mutations proposed for both AS-sens and AS-ART and that therefore did not arise within the AS lineage. Heterozygous and “multiple variant” SNPs, as well as small indels called by less than three reads and less than 50% of the total reads were also removed. Larger indels ( $>3$  bp) and CNVs were detected with both MAQ and SSAHA2 using “comparative coverage” analysis, which measures the ratio of the relative coverage (local coverage divided by overall mean coverage) in AS-ART relative to AS-sens. A comparative coverage ratio  $>1.5$  over 200 bp for defining CNVs and  $<0.25$  over 10 bp for defining indels (both adjusted for different genome coverage in AS-sens and AS-ART) were used, as previously described [30]. Unlike previous work, “comparative coverage” analysis was also performed using MAQ. This required running the “pileup” command on both the AS-ART and AS-sens reads using the variable “-q 1” (which excludes reads with a mapping quality  $<1$ ). The pileup files thus produced were then used for “comparative coverage” analysis with custom made scripts,

similarly to the SSAHA2 approach. Confidence levels were assigned to mutations based on the following criteria: a) Samtools quality scores (for SNPs) and b) identification by both MAQ and Samtools (for SNPs and large indels/CNVs). All high confidence putative point mutations proposed by MAQ and/or Samtools were verified by di-deoxy sequencing. Only limited verification was done for potential indels and CNVs. Small indels were defined as “low confidence” mutations by default, due to a majority of calls being confirmed as false positives by di-deoxy sequencing in this and other studies [30,33].

### **Protein structure-function analysis**

The *P. chabaudi* AP2-mu sequence was used to search the protein structure database (PDB) for homologues. The closest match found was the  $\mu$  chain of AP2 from *Rattus norvegicus*, with a bit score of 167 and an *E*-value of  $2e-41$ . 11 different structure entries of this and related proteins and complexes were present in the PDB. Structure 2PR9 was selected because of the level of R-factors (R: 0.204, R-free: 0.240) and its resolution (2.51Å).

The I-TASSER server [40] was used to construct a homology model of the *P. chabaudi* homologue, with the *R. norvegicus* 2PR9 structure as a template onto which the *P. chabaudi* sequence was modelled. The same method was used to construct a *P. falciparum*  $\mu$  model.

### ***Plasmodium falciparum* isolates- in vitro responses to ART derivatives**

In the present study, we intended to characterize the genetic variation in the *P. falciparum* *ap2-mu* gene in natural infections and to check whether any polymorphism correlated with the parasite’s previously determined responses to ART derivatives. We re-analysed artemisinin responses obtained previously from a collection of isolates of *P. falciparum* from Rwanda, the Democratic Republic of São Tomé & Príncipe (São Tomé) and Brazil [41, 42, 43]. These previous studies had shown that samples displayed a broad range of *in vitro* responses in all countries and for all the ART derivatives tested. Additionally, such differences in IC<sub>50</sub> values, were shown previously not correlate with previously suggested markers of ART resistance, namely, *pfmdr1*, *pfatpase6*, *pfcr1* or *pftctp* (Table 1).

**Table 1.** *P. falciparum* isolates used in the present study, with previously characterized genotypes and *in vitro* responses to artemisinin derivatives

Country and drug tested	N	Mean IC <sub>50</sub> (nM)	Range IC <sub>50</sub> s (nM)	Molecular markers investigated
<b>Rwanda</b>				
Dihydroartemisinin	74	2.6	0.3 – 14.3	<i>mdr1, PfATPase6, pfcr1, pftctp</i> (unpublished)
<b>São Tomé</b>				
Artesunate	42	0.58	0.05 - 9.0	<i>mdr1, PfATPase6, pfcr1, pftctp</i> [42]
Artemether	51	1.12	0.2 – 12.5	
<b>Brazil</b>				
Artesunate	56	0.85	0.1 – 4.9	<i>mdr1, PfATPase6, pfcr1</i> [43]
Artemether	56	3.0	0.2 – 23.0	

### ***Plasmodium falciparum* ap2-mu genotyping**

DNA was first extracted from all samples above and the reference strain 3D7 according to the method described by Plowe and co-workers [44]. The *P. falciparum* *ap2-mu* gene was then sequenced in a subset of twenty-four *P. falciparum* isolates which were initially selected according to their geographical origin and response to each drug. Thus, we picked 8 samples from Rwanda, 8 from São Tomé and 8 from Brazil, according to their response to artemisinin derivatives (4 samples with the lowest IC<sub>50</sub> and the 4 with the highest values, from each country) (Table 2).



**Table 2.** *P. falciparum* isolates in which *pfap2-mu* was sequenced with corresponding ART derivative IC<sub>50</sub>S

Site of Sample Collection	Sample ID	Drug	IC <sub>50</sub> (nM)
Rwanda [41]	RW10	Dihydroartemisinin	0.3
	RW32		0.3
	RW58		0.4
	RW30		0.5
	RW57		8.8
	RW106		9.6
	RW77		10.1
	RW40		14.3
São Tomé [42]	STP27	Artesunate	0.02
	STP29		0.03
	STP41		0.04
	STP46		0.05
	STP35		1.7
	STP34		2.0
	STP44		3.4
	STP58		9.0
Brazil [43]	BR58	Artesunate	0.1
	BR05		0.2
	BR15		0.2
	BR45		0.2
	BR38		3.4
	BR07		4.8
	BR67		4.8
	BR68		4.9

The sequence of the *P. falciparum* orthologue of the *ap2-mu* gene (accession n. PF3D7\_1218300) was retrieved from PlasmoDB and used as template for designing primers to amplify its open reading frame using an overlapping PCR fragment strategy (Table 3). PCR assays were performed with 1 µl of DNA into a 50 µl mixture containing 0.2 µM of each primer, 1.5 mM MgCl<sub>2</sub>, 0.2 mM deoxynucleoside triphosphates and 1.25 units of GoTaq® Flexi DNA Polymerase (Promega).

**Table 3.** Primer sequences and PCR reactions for the *pfap2-mu* gene

Primers	Sequence (5' to 3')	Coordinates (length)	PCR Program	
<b>PfCIR-1F</b>	GTTAACACGATTAGCGTCATTTG	-54 to 524	94 °C, 3 min	
<b>PfCIR-2R</b>	GTCCTATTATGTATATGTGGATC	(578 bp)	[94°C, 30'; 53°C, 45'; 72°C, 60'] 72 °C, 10 min	35 cycles
<b>PfCIR-3F</b>	GATATCCACAAACATTAGAAGTG	358 to 1199	94 °C, 3 min	
<b>PfCIR-4R</b>	CCATCTGGTGGTGTGAAGG	(841 bp)	[94°C, 30'; 52°C, 45'; 72°C, 60'] 72 °C, 10 min	35 cycles
<b>PfCIR-5F</b>	GCATATTCATCATTGTGTTACC	1126 to +58	94 °C, 3 min	
<b>PfCIR-6R</b>	ACACCCGATTGAACTATTATAC	(753 bp)	[94°C, 30'; 53°C, 45'; 72°C, 60'] 72 °C, 10 min	35 cycles

PCR products were analysed by ethidium bromide-stained agarose 2% gel electrophoresis and sequenced directly in both sense and antisense directions with the appropriate PCR amplification primer.

### ***PIRA-PCR and RFLP***

One particular mutation in the *pfap2-mu* gene (G479A) encoding an S160N replacement, was determined in all samples characterized for their *in vitro* response to artemisinin derivatives using a PCR-restriction fragment length polymorphism (RFLP) assay. Since this point mutation does not create a natural endonuclease restriction site, a primer introduced restriction enzyme analysis PCR (PIRA-PCR) method was used.

A PIRA primer PfCLR-G479A-F (forward) with sequence 5'-ATC AAA TGA ATT ATT AAA TGT AAc TA -3' was thus designed, where an A-to-C mismatch was incorporated at the 3<sup>rd</sup> base position from 3'-end terminus (shown in small letter in primer sequence). This creates a recognition site (ACTAGT) for the restriction enzyme *BclI* in presence of the wild type allele G479.

A PCR product was amplified using primers PfCLR-G479A-F and PfCLR-G479A-R (sequence: 5'- AAA ATG ATT TGC TGT CTT ATT A -3') with final concentration of 0.2  $\mu$ M, of each primer, 1.5 mM MgCl<sub>2</sub>, 0.2 mM dNTPs and 1.25 units of GoTaq® Flexi DNA Polymerase (Promega). Conditions of PCR were: initial denaturation at 94 °C for 3 min, followed by 40 cycles of 94 °C for 30 s, 51 °C for 45 s and 72 °C for 60 s, and a final extension step of 72 °C for 10 min. 10  $\mu$ l the PCR reaction mixture was digested with 20 units of *Bcu*I restriction enzyme (Fermentas) with 1  $\times$ Buffer Tango in a final volume of 20  $\mu$ l and incubated at 37 °C for 3 h. The predicted size of the PIRA-PCR product resulting from amplification with primers PfCLR-G479A-F and PfCLR-G479A-R is 268 bp, which can then be cleaved into 245 and 23 bp fragments when digested with *Bcu*I, in the presence of the wild-type (*wt*) allele (AGT). No cleavage is expected in the presence of mutant (*mut*) allele (AAT). The 268 and 245 bp fragments can be easily resolved on 3 % agarose gel, whereas the 23 bp fragment is normally difficult to visualize or discriminate from primer-dimers. Therefore, the 245 bp band was scored as *wt* and 268 bp as *mut*. Figure 2 shows typical results of these PIRA-PCR assays.

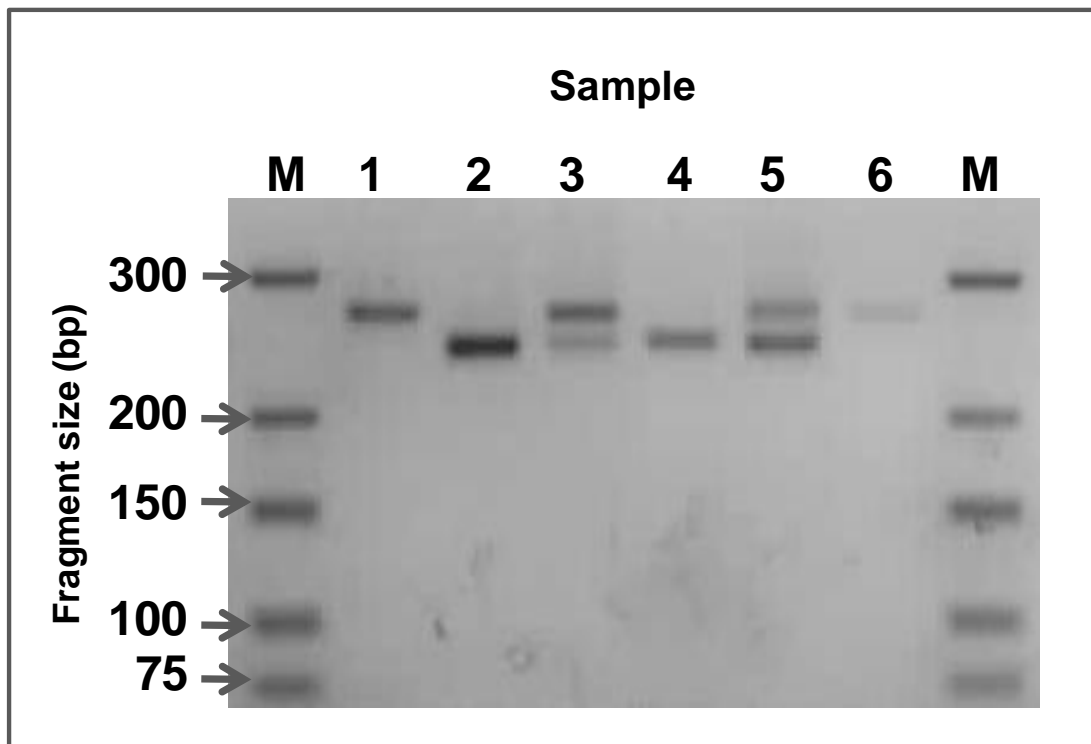

**Figure 2. Typical results of the *Pfap2-mu* gene PIRA-PCR results.** M: molecular weight marker. Lanes 1 and 6: *Pfap2-mu* 160N variants; lanes 2 and 4 *Pfap2-mu* 160S variants; lanes 3 and 5: mixture of genotypes. Samples were run in 3% agarose gels stained with ethidium bromide

### **Data analysis**

In the absence of recent contact with drugs, *P. falciparum* populations generally display a log-concentration normal distribution regarding enzyme-inhibiting compounds. The D'Agostino and Pearson omnibus normality test [45] was used to infer whether or not the IC<sub>50</sub> values obtained for our samples follow a log-normal distribution. Grubbs outlier test was used to test for and exclude statistical outliers. The parametric two tailed t-test (with significance level set at 0.05) was applied to test whether or not there are significant differences between *in vitro* artemisinin derivatives response and the S160N mutation in the PfAP2-mu adaptor protein. The normality tests, t-tests and plots were done using GraphPad Prism 4.0 (GraphPad Software, San Diego, California). Grubbs outlier test was done using R software version 2.11.1 (The R Foundation for Statistical Computing).

In order to evaluate whether the distribution of the S160N genotype correlated significantly with ART IC<sub>50</sub>s, the following statistical analyses were carried out. We first performed normality tests to infer whether or not the IC<sub>50</sub> values obtained for our samples followed a log-concentration normal distribution. The untransformed wild-type data deviated from a normal distribution, as confirmed by D'Agostino and Pearson omnibus normality test, with all values of  $p < 0.0001$ . After log-transformation, IC<sub>50</sub>s were log-normally distributed, with p-values equal to 0.29, 0.18 and 0.054 for Rwanda (Dihydroartemisinin), São Tomé (Artesunate) and São Tomé (Artemether), respectively. The mutant datasets also followed a log-normal distribution with the exception of Rwanda (p-value = 0.013). This deviation arose from an outlier identified by the Grubbs outlier test (p-value = 0.00026). After removal of this outlier the Rwandan distribution conforms to a log-normal distribution (p-value=0.83). The ensuing analyses were therefore performed excluding this outlier.

F tests were performed to assure that the variances were not significantly different between wild-type and mutant data. Table 12 summarizes the results of the statistical tests performed.

## Results

### The *Plasmodium chabaudi* AS-ART phenotype

Here, the ART responses of isogenic parasites of the *P. chabaudi* AS lineage are investigated further; namely, AS-3CQ (ART-S clone), AS-30CQ (ART-R clone) and the AS-ART (ART-R clone) generated during selection by ART (Figure 1) [25]. In previous work, artemisinin resistance at 100 mg ART kg<sup>-1</sup> (body weight) d<sup>-1</sup> was demonstrated in both AS-30CQ and AS-ART relative to other clones, which preceded them in the AS lineage, including AS-3CQ [30]. Here, the hypothesis that AS-ART would resist higher doses of ART than AS-30CQ is tested. Parasites were treated for three (1 × 10<sup>6</sup> inoculum) or five (1 × 10<sup>7</sup> inoculum) days (treatments A and B, respectively) with a daily dose of 200 mg ART kg<sup>-1</sup> d<sup>-1</sup> and their response to the drug was assessed by comparing both peak parasitaemia and the time taken for each parasite to recrudescence after treatment.

In the absence of treatment, all three parasite clones produced their peak parasitaemia of between 23% (AS-ART) and 40% (AS-30CQ), appearing between days 8 and 9 pi (Figure 3A). Under either ART treatment A and B however, no parasites were detected in mice infected with AS-3CQ over the follow-up period (Figure 3B and 3C). After treatment A, AS-30CQ produced detectable parasites between days 13–14, with parasitaemia reaching their peak (~12%) on day 17. However, mice infected with AS-ART presented more rapid recrudescence (days 8–9), with parasitaemia reaching ~12% on day 15 after treatment (Figure 3B). A similar trend was observed after treatment B: mice infected with AS-30CQ first presented a detectable parasitaemia between days 13–14 and peak parasitaemia (~10% on day 18), whilst the AS-ART group recrudescenced three days earlier (Figure 3C) achieving a similar peak parasitaemia on day 15.

As previously reported [30] it is concluded that AS-3CQ is sensitive to ART treatment whereas both AS-30CQ and AS-ART are resistant. Here, however, at high ART doses, AS-ART shows both earlier recrudescence and reduced time to reach peak parasitaemia relative to AS-30CQ. It is concluded that AS-ART has a higher degree of resistance to ART. Here, this enhanced resistance phenotype is called ART-R phenotype 2. The response of AS-30CQ and AS-ART to 100 mg ART kg<sup>-1</sup> d<sup>-1</sup> (3 day) is called ART-R phenotype 1.

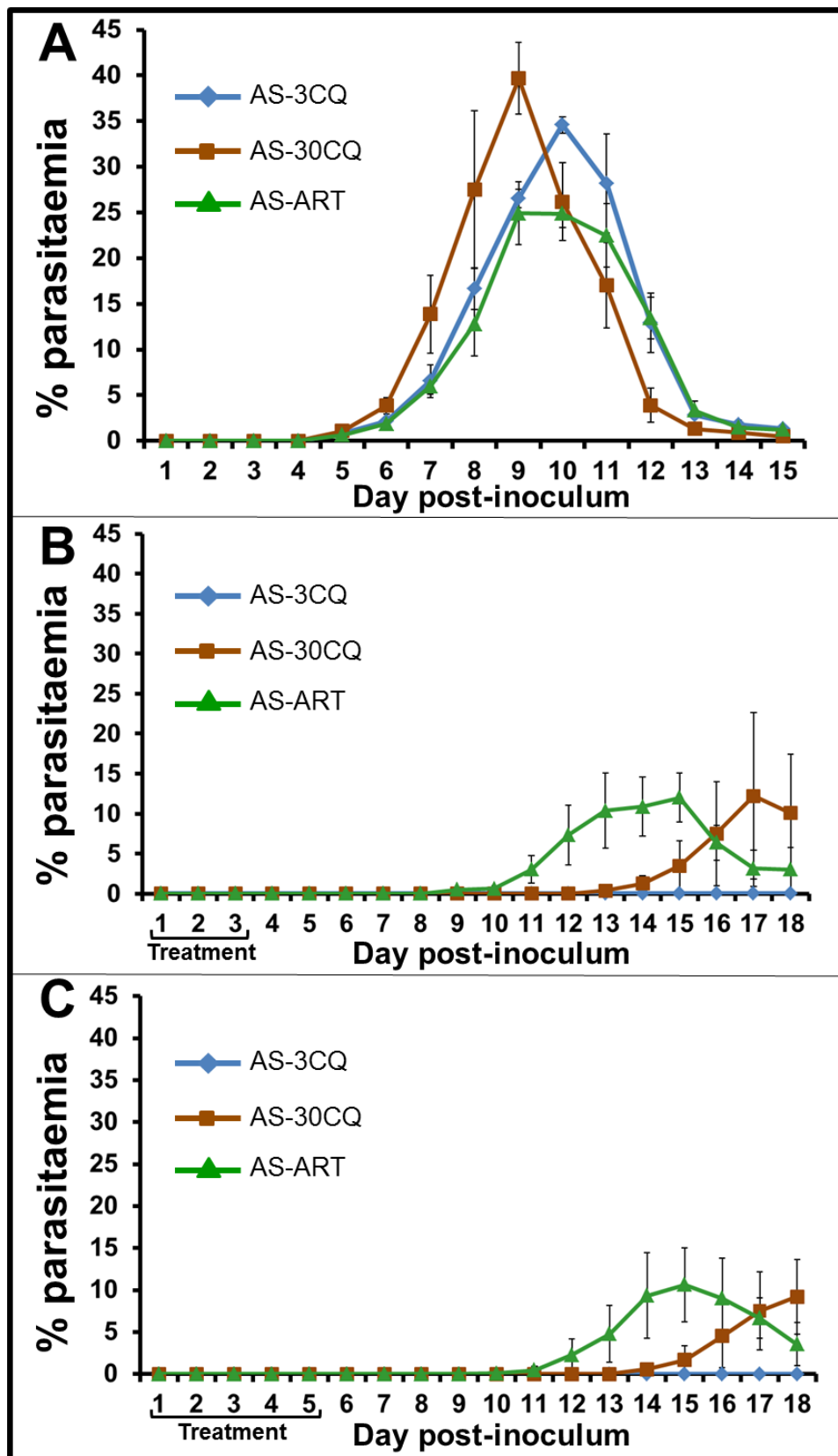

**Figure 3** Artemisinin responses of *Plasmodium chabaudi* AS-3CQ, AS-30CQ and AS-ART. Mean% parasitaemia  $\pm$  standard error of groups of three mice. **A**, untreated controls; **B**,  $1 \times 10^6$  parasites on day 0 and treated with  $200\text{mg ART}/\text{kg}^{-1} \text{ day}^{-1}$  days 1-3; **C**,  $1 \times 10^7$  parasites on day 0 and treated with  $200\text{mg ART}/\text{kg}^{-1} \text{ day}^{-1}$  days 1-5. AS-sens, blue; AS-30CQ, red; AS-ART, green [The experimental work contributing to this figure was done by Gisela Henriques and Louise Rodrigues].

## Genome re-sequencing of AS-ART

AS-ART was sequenced using the Illumina platform using 36 base single-end reads. In total, 45,879,892 short single-end reads were produced for clone AS-ART, of which 89 % were mapped onto the 2009 version of the reference genome (Wellcome Trust Sanger Institute *P. chabaudi* AS parasite, AS-WTSI, genome size 18,832,196 bp [36]: by the mapping software, SSAHA2. The mean genome-wide read coverage was 84 reads per nucleotide (Table 4). Approximately 87% of the total reads (39,979,351) were mapped in unique positions. Some 98% of the nucleotides in the genome were covered by at least 10 reads and 93% by at least 40 reads; 1.67% was covered by less than three reads (the minimum required for SNP and small indel detection). Similar data were obtained using an alternative mapping software, MAQ. Clones AS-sens and AS-30CQ had been re-sequenced previously and reads aligned similarly [30,31,33].

**Table 4.** Summary of the Solexa whole genome re-sequencing performed on clone AS-ART of *Plasmodium chabaudi*

Clone analysed	AS-ART
Reference sequence	Sanger (09/2009)
Read length	36
Total Number of Reads	45.879.892
Mapped Reads (SSAHA2)	41.198.901
Uniquely Mapped Reads (SSAHA2)	39.979.351
% Genome covered by >= 10reads	98,00%
% Genome covered by <3 Reads	1,67%
x coverage (SSAHA2)	84.16X
x coverage (MAQ)	86.18X

## SNP detection

Preliminary SNP calling and filtering (see Methods) identified eight point mutations in AS-ART (see Table 5), relative to the resequenced clone AS-sens [30-33]. There were 11 additional low quality SNP calls considered to be false positives (see Table 6).

Table 5. Confirmed and high confidence mutations in the ART-resistant *Plasmodium chabaudi* clone AS-ART (relative to progenitor clone, AS-sens)

Chromosome	Type	Analysis	Nucleotide start	Nucleotide end	reference base	variant base	SSAHA quality	Confirmation of mutation by dideoxy sequencing	<i>P. chabaudi</i> gene ID	Amino acid change	Nearest gene ID ( <i>P. chabaudi</i> )	<i>P. falciparum</i> orthologue
<b>SNPs</b>												
2	SNP	SSAHA/MAQ	216,954		C	A	99	confirmed	PCHAS_020720	<b>V2728F</b>		PF3D7_0104300
3	SNP	SSAHA/MAQ	70,553		G	T	99	confirmed	PCHAS_030200	<b>T707N</b>		None
3	SNP	SSAHA/MAQ	474,123		C	A	99	confirmed	PCHAS_031370	<b>T719N</b>		PF3D7_0214800
7	SNP	SSAHA/MAQ	994,546		G	A	99	confirmed	PCHAS_072830	<b>S106N</b>		PF3D7_0417200
10	SNP	SSAHA/MAQ	634,932		T	C	99	confirmed	PCHAS_101550	<b>Y162H</b>		PF3D7_1430000
11	SNP	SSAHA/MAQ	996,332		G	T	99	confirmed	PCHAS_112780	<b>A173E</b>		PF3D7_0629500
14	SNP	SSAHA/MAQ	936,945		T	G	92	confirmed			5'-PCHAS_142600	PF3D7_0813400
14	SNP	SSAHA/MAQ	1,270,184		T	C	99	confirmed	PCHAS_143590	<b><u>I568T</u></b>		PF3D7_1218300
							approximate size	comparative coverage				
<b>Indels</b>												
4	indel	SSAHA/MAQ	793,940	793,988	49		0.16	tbc			PCHAS_042080-5	None
5	deletion	SSAHA/MAQ	683,724	684,989	1,266		0.21	tbc	PCHAS_051920			None
7	deletion	SSAHA/MAQ	876,907	876,921	15		0.18	34bp deletion			PCHAS_072420-3'	PF3D7_0815700
bin	indel	SSAHA/MAQ	261,129	284,496	23,368		0.02	tbc	PCHAS_000700-760		None	

All point mutations and 34 bp deletion (light grey) were confirmed by di-deoxy sequencing. A small deletion on chromosome 4 and large deletions on chromosome 5 and 'bin' (dark grey), have strong supporting evidence (extended area of low and zero coverage, SNP-proxies for deletions). Base quality scores (which only apply to SNPs) are derived from the SSAHA2 algorithm (with 99 being the best score). For indels, the approximate size of the affected area (as measured by SSAHA2) and a comparative coverage are given. Amino acid substitutions (non-synonymous mutations) are in bold characters. One point mutation in AP2-mu chain specific to AS-ART (relative to preceding clone, AS-30CQ) is in bold and underline characters. Tbc: to be confirmed.



**Table 6.** AS-ART Genome re-sequencing – validated and low-confidence point mutations

Chromosome	Position	Analysis	Reference base	AS-ART base	SSAHA2 Quality score	Confirmation of mutation by di-deoxy sequencing	<i>P. chabaudi</i> Gene ID	Mutation	<i>P. falciparum</i> orthologue	Nearest gene ID ( <i>P. chabaudi</i> )
1	551,969	SSAHA	G	A	3		intergenic		None	PCHAS_011470-5'
2	216,954	SSAHA/MAQ	C	A	99	YES	PCHAS_020720	<b>V2728F</b>	PF3D7_0104300	
3	25,017	SSAHA	G	A	5		intergenic		None	PCHAS_030080-5'
3	70,553	SSAHA/MAQ	G	T	99	YES	PCHAS_030200	<b>T707N</b>	None	
3	474,123	SSAHA/MAQ	C	A	99	YES	PCHAS_031370	<b>T719N</b>	PF3D7_0214800	
5	684,091	SSAHA	T	A	33		PCHAS_051910-20	non-syno	None	
7	31,783	SSAHA	T	C	5		intergenic		PF3D7_1033400	PCHAS_070080-5'
7	72,468	SSAHA	T	A	8		PCHAS_070170	K-N	None	
7	994,546	SSAHA/MAQ	G	A	99	YES	PCHAS_072830	<b>S106N</b>	PF3D7_0417200	
10	634,932	SSAHA/MAQ	T	C	99	YES	PCHAS_101550	<b>Y162H</b>	PF3D7_1430000	
10	1,625,436	SSAHA	C	T	7		intergenic		None	5'-PCHAS_104250
11	996,332	SSAHA/MAQ	G	T	99	YES	PCHAS_112780	<b>A173E</b>	PF3D7_0629500	
12	875	SSAHA	A	G	12		PCHAS_120010	nonsyn	None	
14	936,945	SSAHA/MAQ	T	G	92	YES	intergenic		PF3D7_0813400	5'-PCHAS_142600
14	1,270,184	SSAHA/MAQ	T	C	99	YES	PCHAS_143590	<b>I568T</b>	PF3D7_1218300	
bin	5,256	SSAHA	G	C	13		PCHAS_000020	A-G	None	
bin	106,638	SSAHA	A	C	3		PCHAS_000260	N-T	None	
bin	177,899	SSAHA	A	G	2		PCHAS_000480	Y-C	None	
bin	270,747	SSAHA	T	A	31		intergenic		None	PCHAS_000730-5'

Summary of all point mutations proposed prior to stringent analysis and filtering (see text) in AS-ART. Those confirmed by di-deoxy sequencing (light grey) are indicated. Low probability mutations (dark grey, see Results) are indicated. For intergenic SNPs, the nearest *P. chabaudi* gene is indicated, with indication as to whether it lies to the left or right of 5' or 3' end of gene. For example, 5' - PCHAS\_011470 indicates that the mutation is found to the left (upstream) of the 5' end of PCHAS\_011470. For 11 low-confidence (black) point mutations, 6 lie within predicted genes (chr05, chr07, chr12 and bin (3)). Two of these (chr05 and chr12) are non-synonymous. Candidate on chr05 is considered as 'proxy for deletion' (see main text).

Eight point mutations identified by both Samtools and MAQ had higher quality scores ( $\geq 92$ , maximum 99) (Methods) than the other 11 (quality scores  $< 34$ , see Table 6) calls, and were subsequently verified by di-deoxy sequencing in AS-ART (Table 5). Seven of these eight were previously reported from the AS-ART progenitor, AS-30CQ [30,31]. They include five point mutations, previously linked to drug resistance phenotypes. These are: a) S106N *dhfr* (encoding dihydrofolate reductase) (PCHAS\_072830), (quality score: 99), which confers pyrimethamine resistance [33]; b) A173E (quality score: 99) in an amino acid transporter (*aat1*, PCHAS\_112780), conferring chloroquine resistance [31]; c) T719N (quality score: 99) in a hypothetical protein (PCHAS\_031370) conferring intermediate chloroquine resistance [31]; and, d) a V2728F (quality score: 99) substitution in the *ubp1* gene (PCHAS\_020720), conferring artemisinin resistance phenotype 1 [30], high-level chloroquine resistance [31] and mefloquine resistance [32]. A fifth point mutation namely T707N (quality score 99) in a member of the *P. chabaudi*-specific interspersed repeat (*cir*) gene family (PCHAS\_030200) may also contribute to the intermediate CQ-R phenotype of AS-30CQ [31]. In all cases, the position of their appearance in the *P. chabaudi* AS lineage coincides with the appearance of the corresponding drug-resistance phenotype. Two point mutations have not been linked to any particular phenotype. These are: Y162H (quality score 99) in a gene annotated as a hypothetical protein (PCHAS\_101550) appearing first in AS-30CQ, and an intergenic mutation (quality score: 92) at base position 936,945 on chromosome 14, located between genes PCHAS\_142590 and PCHAS\_142600 (both hypothetical proteins with no significant Pfam matches), first appearing in AS-PYR1, the first drug-resistance clone of the lineage.

One point mutation *only* in clone AS-ART relative to AS-30CQ was confirmed. This mutation was I568T (quality score 99) in a gene (PCHAS\_143590) predicted to encode the mu ( $\mu$ ) chain of the AP2 adaptor protein complex, which, in other organisms, is involved with clathrin-mediated endocytosis [46]. This gene was denoted *ap2-mu*.

In contrast to the eight confirmed mutations above, the other 11 low-quality calls (see Table 6, highlighted in dark grey) were predicted only by Samtools; nine of these have extremely low Samtools quality scores (2 to 13) and were variously mapped to the extreme ends of chrs 01, 03, 07 (two), 10 and 12, where *P. chabaudi*-specific genes are located (often in multigene families), or to contigs yet to be mapped to the final genome assembly (three in 'bin'). Here, read alignment may be less reliable, as reflected in their low mapping quality. A similar low quality SNP call in AS-30CQ was previously identified as a false positive by di-deoxy-sequencing [33]. Accordingly, these nine low confidence SNPs are strongly predicted to be false positives. In any case, their genomic locations suggest that

they would be unlikely to play a role in a conserved artemisinin resistance phenotype because four of these candidates were intergenic (chr01, 03, 07, 10) and the other five (chr07, 12 and bin (three)) were in genes without orthologues in *P. falciparum*, in contrast to the eight confirmed point mutations.

The two remaining low confidence point mutations mapped to chr05 or contig11844 and had higher quality scores (33 and 31, respectively). However, they were located close to, or within extended regions of low coverage proposed to be deletions (one of which, on chr05, was previously noted) [31], see below. False positive SNPs such as these were previously termed ‘proxies for deletions’ and their artefactual appearance explained [30].

It is concluded that the I568T mutation in the gene PCHAS\_143590 encoding the  $\mu$  chain of the AP2 adaptor protein complex is likely to be the only point mutation in AS-ART relative to its immediate precursor AS-30CQ.

### Small indels, larger deletions and CNV detection

Forty-one potential insertions or deletions (indels) (14 larger (>3bp) indels, 27 small ( $\leq 3$  bp) indels) and seven potential copy number variants (CNVs) were called (see Tables 7, 8 and 9) in AS-ART relative to AS-sens. The specific detection and identification of large insertions was not feasible because the single-end sequencing data used in these studies were not able to support the use of more sophisticated detection algorithms that depend upon the availability of paired-end data.

The 27 small indels were considered to be low confidence predictions, *ie*, false positives. Dideoxy-sequencing confirmed that the five tested were all false positives (see Table 7), as in previous studies of AS-15MF and AS-30CQ [30,33]. It is suggested that the majority of these predicted low confidence mutations are therefore false positives. In any case, only six of the other 22 small indels were intragenic.

For larger indels, analysis based on read depth reveals large deletions (say >20 bp) with greater reliability than for intermediate deletions (say 3<bp<20) and all larger insertions. Four (see Table 8, highlighted in grey) of the 14 intermediate and large indels candidates were classified as high confidence mutations (Table 9, Methods), principally because they were predicted using both MAQ and SSAHA2 but also because they generate consistently low read coverage over an extended region. Also, three (chr04, 05, 07) were previously identified in the progenitor clone AS-30CQ or in a related clone AS-15MF [30,31]. One of these was previously confirmed by dideoxy-sequencing as an intergenic 34 bp deletion on

chr07. Another was a potential large deletion (>1 kb) on chromosome 5 located within a gene coding for a non-syntenic (*i.e.* its chromosomal location is not conserved across malaria species relative to surrounding genes) S-antigen (PCHAS\_051910-20). The third was a deletion in non-coding sequence at the right hand end of chromosome 4, in a region previously defined to be the site of deletion and translocated copy of a large duplicated chr12 fragment containing *mdr1* in the related clone AS-15MF [32]. The remaining high confidence large deletion corresponds to a potential ~23 kb deletion on an unassigned contig ('bin' contig11844), not predicted in the progenitor clone AS-30CQ, spanning several non-syntenic genes (PCHAS\_000700 to PCHAS\_000760). The regions corresponding to deletions on chr05 and in contig 11844 also contain an example of a SNP 'proxy for deletion' (see section above). Verification of the three deletions (in chr04, chr05 and contig 11844) by di-deoxy sequencing was not possible due either to their size or position or both. For the other 10 larger deletion candidates, six are intergenic and four are predicted to interrupt *P. chabaudi*-specific genes, three mapping to the extreme ends of chr13 (two) and chr14, and one to an unassigned contig (see Table 8).

It is worth noting that the frequency of indels in the chicken and human genomes (e.g. [47,48]) is less than the SNP frequency; confirmed in next generation short-sequencing analysis [49]. If applicable to *Plasmodium* spp, the number of indels will be less than the number of point mutations. Since the number of point mutations in AS-ART (relative to AS-sens) is likely to be eight, the four high-confidence deletions detailed above may represent the full complement of indels. Only one (in contig 11844) appears in AS-ART, relative to AS-30CQ.

For the seven potential CNVs, identified by higher read comparative coverage (range 1.5 – 3.1), they extend over very small regions (205–282 bp) and lie outwith coding regions of genes (see Table 9). In other clones of the *P. chabaudi* AS lineage, previously validated large-fragment CNVs (involving *mdr1*) were identified using a similar comparative read-coverage analysis ([32] and data not shown). In the present case, the seven potential CNVs are unlikely to represent gene duplication/amplification events, simply reflecting natural variation of read coverage.

It is likely that there is only one high-confidence deletion (contig 11844) arising in AS-ART relative to AS-30CQ. The likelihood of other indels or CNVs arising in AS-ART is considered to be low and, in any case, unlikely to confer artemisinin resistance phenotype

2.

**Table 7.** AS-ART Genome re-sequencing – low probability small Indels

Chromosome	Insertion or Deletion	Nucleotide start	Nucleotide finish	Size of region	Small indel quality index	Dideoxy-sequencing validation	<i>P. chabaudi</i> gene ID	Nearest <i>P. chabaudi</i> gene ID
1	Insertion	203,105	203,105	1	22/38		intergenic	5-PCHAS_010530
2	Insertion	32	32	1	5/10		intergenic	3-PCHAS_020010
4	Deletion	104,874	104,874	1	33/49		intergenic	PCHAS_040280-5
5	Deletion	281,711	281,711	1	3/5		intergenic	3-PCHAS_050670
5	Deletion	716,257	716,257	1	23/38		intergenic	PCHAS_052010-5
6	Insertion	430,538	430,538	1	110/118	NO	PCHAS_061120	
6	Deletion	678,850	678,851	2	3/6		intergenic	3-PCHAS_061760
7	Deletion	779,270	779,270	1	314/200		PCHAS_072120	
7	Deletion	910,035	910,035	1	7/9		intergenic	PCHAS_072520-5
7	Insertion	910,341	910,341	1	9/12		intergenic	3-PCHAS_072530
8	Insertion	854,448	854,448	1	22/35	NO	PCHAS_082240	
9	Deletion	1,113,660	1,113,660	1	62/82		PCHAS_093250	
10	Deletion	290,661	290,661	1	81/84	NO	intergenic	3-PCHAS_100680
10	Deletion	719,577	719,577	1	6/8		intergenic	PCHAS_101800-3
10	Deletion	908,717	908,718	2	118/155	NO	PCHAS_102390	
10	Insertion	1,625,438	1,625,438	1	3 / 4		intergenic	5-PCHAS_104250
11	Insertion	694,180	694,180	1	314/452		intergenic	3-PCHAS_111970
11	Deletion	760,507	760,507	1	47/62	NO	PCHAS_112150	
11	Deletion	836,567	836,567	1	54/80		PCHAS_112370	
13	Deletion	1,792,799	1,792,799	1	7/13		intergenic	3-PCHAS_134780
14	Insertion	9,124	9,124	1	3/3		intergenic	3-PCHAS_140040
14	Deletion	54,440	54,440	1	3/6		intergenic	PCHAS_140140-3
14	Insertion	82,779	82,779	1	3/3		intergenic	5-PCHAS_140200
14	Deletion	347,257	347,257	1	39/58		PCHAS_140880	
14	Deletion	926,444	926,444	1	20/32		PCHAS_142560	
14	Insertion	1,415,664	1,415,664	1	4/7		intergenic	PCHAS_143940-5
bin	Deletion	352,973	352,973	1	161/166		PCHAS_000930	

Summary of all small indels predicted (see text) in AS-ART. Analysis was done using the SSAHA package. Those rejected by di-deoxy sequencing are indicated (light grey). Other small indels (dark grey) are expected to represent false positives (see text). Quality scores indicate no of reads calling indel/total reads. For intergenic small indels, the nearest *P. chabaudi* gene is indicated, with indication as to whether it lies to the left or right of 5' or 3' end of gene. For example, 5' - PCHAS\_010530 indicates that the mutation is found to the left (upstream) of the 5' end of that gene.

**Table 8.** AS-ART Genome re-sequencing – larger indels

chromosome	Analysis	Nucleotide start	Nucleotide finish	Size of region	comparative coverage	Dideoxy-sequencing validation	<i>P. chabaudi</i> gene ID	Nearest <i>P. chabaudi</i> gene ID
1	SSAHA	127	149	23	0.17		intergenic	
3	SSAHA	62	207	146	0.12		intergenic	5-PCHAS_030010
4	SSAHA/MAQ	793,940	793,988	49	0.16	tbc	intergenic	PCHAS_042080-5
5	SSAHA	544,355	544,403	49	0.24		intergenic	PCHAS_051440-5
5	SSAHA/MAQ	683,722	684,999	1,278	0.21	tbc	PCHAS_051910-20	
7	SSAHA	56,889	56,899	11	0.11		intergenic	PCHAS_070140-5
7	SSAHA/MAQ	876,902	876,929	28	0.18	34bp deletion	intergenic	PCHAS_072420-3
13	SSAHA	36,490	36,500	11	0.17		PCHAS_130090	
13	SSAHA	1,598,774	1,598,789	16	0.22		PCHAS_134220	
14	SSAHA	943,900	943,923	24	0.21		intergenic	5-PCHAS_142620
14	SSAHA	2,277,029	2,277,055	27	0.24		PCHAS_146230	
bin	SSAHA	116,319	117,071	753	0.19		intergenic	3-PCHAS_000290
bin	SSAHA/MAQ	261,129	284,496	23,368	0.02	tbc	PCHAS_000700-760	
bin	SSAHA	300,040	300,050	11	0.19		PCHAS_000790	

Regions of low comparative coverage (see Methods) were identified. 4 higher probability larger indels (see text) are indicated (light grey, not validated or dark grey, validated). Indels of low probability are indicated (not coloured). For intergenic indels, the nearest *P. chabaudi* gene is indicated, with indication as to whether it lies to the left or right of 5' or 3' end of gene. For example, 5' - PCHAS\_030010 indicates that the mutation is found upstream of the 5' end of that gene.

**Table 9.** AS-ART Genome re-sequencing – possible CNVs

chromosome	Nucleotide start	Nucleotide finish	Size of region	comparative coverage	Nearest <i>P. chabaudi</i> gene ID
3	349,895	350,122	228	2.90	5-PCHAS_031010
6	678,733	678,961	229	1.50	3-PCHAS_061760
7	677,772	678,012	241	2.40	PCHAS_071850-5
8	814,443	814,647	205	2.50	PCHAS_082110-5
12	926,886	927,167	282	2.80	5-PCHAS_122590
14	1,595,074	1,595,327	254	1.60	3-PCHAS_144430
14	1,758,897	1,759,122	226	3.10	3-PCHAS_144820

Regions of high comparative coverage (see Methods) was used to identify potential CNVs. Analysis was done using the SSAHA package. These regions are all considered low probability (see Results). All CNVs were intergenic, the nearest *P. chabaudi* gene is indicated, with indication as to whether it lies to the left or right of 5' or 3' end of gene. For example, 5' - PCHAS\_031010 indicates that the mutation is found to the left (upstream) of the 5' end of that gene.

### Conservation and structure of AP2 mu-chain

An alignment of the predicted amino acid sequences of *AP2-mu* of *P. chabaudi* (PCHAS\_143590, 597 aa) and its *P. falciparum* orthologue, PF3D7\_1218300 (Figure 4A) and other *Plasmodium* spp (data not shown) confirm that this gene is highly conserved in *Plasmodium* spp. Specifically, the I568T mutation appears close to the C-terminus in a particularly highly conserved region. BLAST searches identify AP2 adaptor *mu*-chains from other species such as *R. norvegicus* (435 aa) (Figure 4B) showing high sequence conservation in both the N-terminal domain (aa 1–154, numbering *P. chabaudi* unless otherwise stated) and the C-terminal domain (aa 244–597) which forms two subdomains each composed of a  $\beta$ -sheet. These large regions of  $\beta$ -sheets bind to, and hence select cargo protein during coated pit formation and vesicle formation during endocytosis [46,50].

In addition to the conservation of its amino acid sequence, other sequence and structural features of PCHAS\_143590 support its designation as the  $\mu$ -chain of the AP2 adaptor complex and a role in recognition of cargo protein and endocytosis. Residues 155 to 243 comprise *Plasmodium* specific sequence and extend the linker (rat136 – 158) between the *AP2-mu* N-terminal and C-terminal domains. At its C-terminal end, this linker contains T245, homologous to rat T156 that requires phosphorylation for endocytosis *in vitro* and *in vivo* [51]. Also, the *P. chabaudi* protein contains 17 lysine residues (aa 410 – 537) in a region where positively charged patches in rat  $\mu$ -chain interact with phosphatidylinositol bisphosphate (PIP<sub>2</sub>) [52]. Both phosphorylation and PIP<sub>2</sub> or PIP<sub>3</sub> binding stabilize a large conformational change that allows cargo signal motifs to access the  $\mu$ -chain signal recognition site at the membrane surface [53].

BLAST alignments (Figure 4A, 4B) support the designation of *P. falciparum* I592 and *R. norvegicus* V401 as the corresponding residues to *P. chabaudi* I568, suggesting that these residues will have similar positions within the protein structure, and therefore, a corresponding functional significance.

A	
<i>P. c.</i>	1 MIEGLYVFFANGQLLIQRNYRSMTNKNDLKLIVSVKYIKTKRFYEHPIVEINNPFVFLNVSI 60
<i>P. f.</i>	1 MIDALYIFIFINGQLLIQRNYRDTTKRDLTQYINKYIKTKRFYENPIVEINNPFVFINVNI 60
<i>P. c.</i>	61 NEIVITALTKNNANICLIFNFIYKFIIEILKYFFDDEISRINIINNPFVLIYDICEDEIIDYG 120
<i>P. f.</i>	61 NEIVITLT++N+NICLIFNFIYKFIIEILKYFF++E+S INI+NNFVLIY+ICDEIIDYG 120
<i>P. c.</i>	121 YPQMLEISVLKNCQLQSKVKYYSRSTSQYFHKLSNEFKCGNLIEDIHDTNLENKSEHLHk 180
<i>P. f.</i>	121 YPQMLEISVLKNCQLQSKVKYYSRSTSQYFHKLSNEFKCGNLIEDIHDTNLENKSEHLHk 180
<i>P. c.</i>	181 kyynfndksnnsnnkkindikkMNSFELSEKNKLKKNIGKEALnrriknkiinniAK---Q 237
<i>P. f.</i>	181 NKSNNKIRDFYNTKSVKNN-----NTYDLNETNKLKYIGKFTLNRIKNNKIINNNSNNKT 235
<i>P. c.</i>	238 PNSFNLTGNCWTWRTNNIYHKKNEIIDIlevl-nvtinnnnliCAHINGKIILKCFLSGM 297
<i>P. f.</i>	236 ANHFNYITGNCWTWRNNIYHKKNEIYDILEILNVTINNNLIYAHINGKVTLKCHLSGM 295
<i>P. c.</i>	298 PICELSTSNKFNMLNN-----KNVASIDGE--NNAKYNEK--KR 332
<i>P. f.</i>	296 PLCELSTNNKINLLKNLAGSNTSNNNNNTSNNNNKTNQGNALRGSCGSNSLVNKNVMQN 355
<i>P. c.</i>	333 NGEPNYGSNNIFEDRKNITIDNCIFHHCNVSSKYNDHKIITFTPPDGFELMRYTVTKNI 392
<i>P. f.</i>	356 NLKKKYTLDE--KDNEBIIIDNCIFHHCVTLSKYENNVITFTPPDGFELMRYTITPKNI 413
<i>P. c.</i>	393 QVPPHISAVYNPVFQYSKYLDKNYSIKKSKGLN---FYDYKNTNKFEYKVTIRSNYSGPM 449
<i>P. f.</i>	414 QIPFHILAIYNPILYYSKVEKFKSLKLTNNKSIYGEYKNTNKYEVSVTIKSNYKGM 473
<i>P. c.</i>	450 NATEIVIKIPIYKFSENVHVYKYSIGKTEFNVENVITWKISKFPGLSEHTIRIYLTLEN 509
<i>P. f.</i>	474 HASDVLIKIPIYKFSENVQVYKYSIGKTEFNVIDSLVIRIKFLSSSEHNKIKHHTLEN 533
<i>P. c.</i>	510 QNQIYSNMNNTQKVDGQSKVVLHVNTVKNMNTVKFLNTYKMPITLNFKIPMFTSSGMFIR 569
<i>P. f.</i>	534 HNQIYSNMNNTQKVDLQSKVVLQVHKIKNMNTVKFLNTYKMPITLNFKIPMFTSSGMFIR 593
<i>P. c.</i>	570 YLKVYEKSNYKIIKWIKYLTEAGAYQYK 597
<i>P. f.</i>	594 YLKVFEKSNYKIIKWIKYLTEAGAYQYK 621
B	
<i>P. c.</i>	244 LTGNCWTWRTNNIYHKKNEIIDIlevl-nvtinnnnliCAHINGKIILKCFLSGMPICEL 302
<i>R. n.</i>	155 VTGQIGWRREGIKYRRNELFLDVLESVLLMSPQGVLSAHVSGRVVMKSYLSGMPCE-- 212
<i>P. c.</i>	303 STSNKFNMLNKNVASIDGENNAYNEKRRNGEPNYGSNNIFEDRKNITIDNCIFHHCVN 362
<i>R. n.</i>	213 ----KFGM-NDKIVIEKQKGTGTA--DETSKSG-----KQSAIDDCFFHQCVR 253
<i>P. c.</i>	363 SKKYNDHKIITFTPPDGFELMRYTVTKNIQVPPHISAVYNPVFQYSKYLDKNYSIKKSK 422
<i>R. n.</i>	254 LSKFDSERSISIFPPDGFELMRYRTKDIILPFRVPLVREV----- 296
<i>P. c.</i>	423 GLNFYDYKNTNKFEYKVTIRSNYSGPMNATEIVIKIPIYKFSENVHVYKYSIGKTEFN 482
<i>R. n.</i>	297 -----GRTKLEVVKVVIKSNFKPSLLAQKIEVRIPPLNTSGVQVICMK-GKAKYKAS 347
<i>P. c.</i>	483 ENVITWKISKFPGLSEHTIRIYLTLENQIQIYSNMNNTQKVDGQSKVVLHVNTVKNMNTV 542
<i>R. n.</i>	348 ENAIVWKIKRMAGMKESQISAEIEL-----LPTNDRKKWA-- 382
<i>P. c.</i>	543 KFLNTYKMPITLNFKIPMFTSSGMFIRYLKVYEK----SNYKIIKWIKYLTEAGAYQYK 597
<i>R. n.</i>	383 -----RPPISMNFEVP-FAPSGLKVIRYLKVFEPKLNYSVDHVIKWVRYIGRSIGYETR 434
<i>P. c.</i>	1 MIEGLYVFFANGQLLIQRNYRSMTNKNDLKLIVSVKYIKTKRFYEHPIVEINNPFVFLNVSI 60
<i>R. n.</i>	1 MIGGLFIYNHRGEVLISRVRDDIGRNAVDAFRVNVIHARQQVRSPTVNIARTSFFHVKR 60
<i>P. c.</i>	61 NEIVITALTKNNANICLIFNFIYKFIIEILKYFFDDEISRINIINNPFVLIYDICEDEIIDYG 120
<i>R. n.</i>	61 SNIWLAAVTKQNVNAAMVFEFLYKMCVMAAYF-GRISEENKNNFVLIYELLDEILDG 119
<i>P. c.</i>	121 YPQMLEISVLKNCQLQSKVKYYSRSTSQYFHKLSNE 154
<i>R. n.</i>	120 YPQNSETGALKTFITQQGIKSHQTKKEEQSITSQ 154

**Figure 4 Conservation of AP2 mu-chain amino acid sequence.** Conservation between *P. chabaudi* (PCHAS\_143590) sequence and (A) *P. falciparum* (PF3D7\_1218300) or (B) rat (P84092 (UniProtKB/Swiss-Prot) sequences. The *P. chabaudi* mutated residue I568 and the corresponding *P. falciparum* residue I592 (A) and Rat V401 (B) are highlighted (purple). Note *Plasmodium* spp.-specific sequence (~90 residues, relative to rat) lying between positions154–244 (*P. chabaudi*). [The experimental work contributing to this figure was done by Pedro Cravo and Paul Hunt].



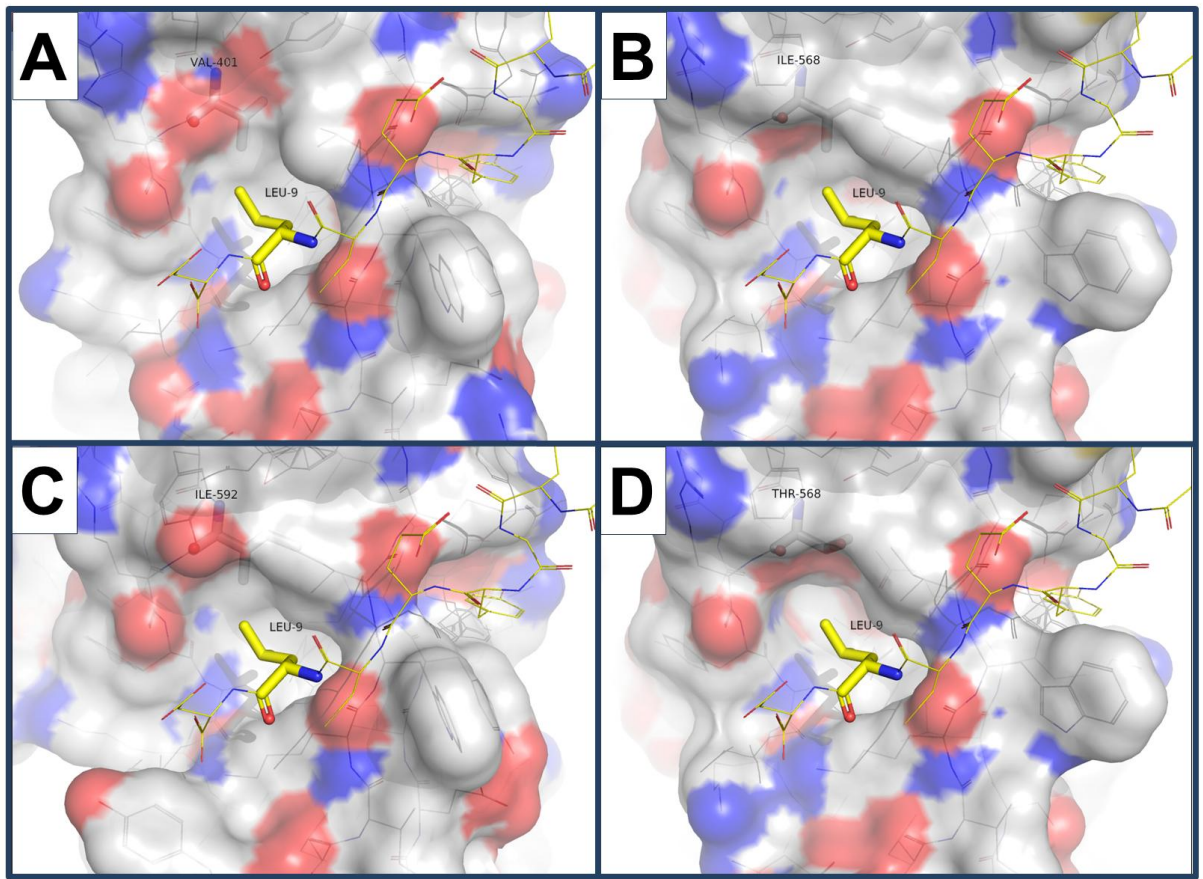

**Figure 5. I568T mutation in AP2  $\mu$ -chain interacts with YXX $\Phi$  motif on cargo protein.** **A.** Rat (P84092) V401 is homologous to *P. chabaudi* AP2  $\mu$ -chain I568, and contributes to the hydrophobic pocket that binds L9 residue of bound peptide (DEEYGYECL) in structure 2PR9. **B.** Homology model for *P. chabaudi* wild-type homologue shows similar structure with I568 corresponding to rat V401. **C.** Homology model for *P. falciparum* orthologue shows similar structure, with I592 corresponding to rat V401 and *P. chabaudi* I568. **D.** Homology model for *P. chabaudi* mutant - 568T is predicted to reduce the hydrophobic character of the binding pocket in which peptide L9 binds. Note increased polar character associated with threonine hydroxyl group in **D** relative to **B**. [The experimental work contributing to this figure was done by Douglas Houston].

X-ray structures for both the  $\mu$ -chain alone or the adaptor complex cocrystallised with peptides containing YXX $\Phi$  (where  $\Phi$  represents a hydrophobic residue such as F, I, V, L or M) recognition motifs on the target (cargo) ligands [54] include a rat  $\mu$ -chain structure (pdb 2PR9), showing that the V401 residue of the rat  $\mu$ -chain is adjacent to the L9  $\Phi$  residue (L, lysine) of the bound DEEYGYECL peptide and, along with rat L173, L175, L404 and V422, forms a hydrophobic pocket into which the  $\Phi$  residue binds (Figure 5A). The high sequence conservation between PCHAS\_143590 and the rat AP2  $\mu$ -chain (Figure 5B, Figure 4B) suggests that I568 will play a similar role in the *P. chabaudi* AP2 adaptor to that of V401 in the rat homologue. Homology models of the *P. chabaudi* structure were predicted by threading the *P. chabaudi* amino acid sequence into the rat crystal structure, using I-

TASSER. The resulting structures indeed show that I568 (*P. chabaudi*, Figure 5B) and I592 (*P. falciparum*, Figure 5C) are predicted to lie in a corresponding position, relative to the  $\Phi$  residue in the bound peptide. The likely effect of the I568T mutation was investigated in the *P. chabaudi* homology model. The most likely conformation of 568T was predicted by minimising the contact of the side chain oxygen atom in 568T to nearby hydrophobic residues. This results in the oxygen pointing towards the solvent, hence forming part of the  $\Phi$ -binding pocket (Figure 5D). The effect of the 568T hydroxyl group is therefore to add some hydrophilic character to the hydrophobic pocket into which the  $\Phi$  residue fits. Similar results were obtained for the *P. falciparum*  $\mu$ 2 homology model (data not shown). The I568T mutation is predicted to moderate but not abrogate the binding of the  $\mu$  subunit to the YXX $\Phi$  recognition motif present in the cargo protein. In any case, at least in yeast, an AP-2  $\mu$ -chain knock-out is not lethal [55] and clathrin may function independently of the adaptor [56]. Similar results were obtained for the *P. falciparum*  $\mu$ 2 homology model (data not shown).

### Analysis of MDR1 as a putative target

*MDR1* is a 12 transmembrane (TM)-domain ATP-binding cassette (ABC) transporter known to be involved in modifying responses of malaria parasites to various drugs [57]. In view of the many reports regarding the effect of *mdr1* amplification on ART responses in *P. falciparum* [57] and in *P. chabaudi* [33], we investigated whether the I568T mutation could interact with *mdr1* and thus affect its localisation and trafficking.

The *P. chabaudi mdr1* amino acid sequence contains many instances of FXX $\Phi$  signals (Figure 6). This suggests that *mdr1* may contain (multiple) signals which regulate the trafficking of *mdr1* from the parasite membrane to other organelles or positions in the endosomal system. Signal sequences tend to be located within 10-40 amino acids of a transmembrane helix [46], or between 6-9 amino acids for proteins destined for the lysosome. We were however unable to identify strong candidate YXX $\Phi$  signals which fulfilled these requirements and which were not structurally constrained to bind to AP2- $\mu$ .

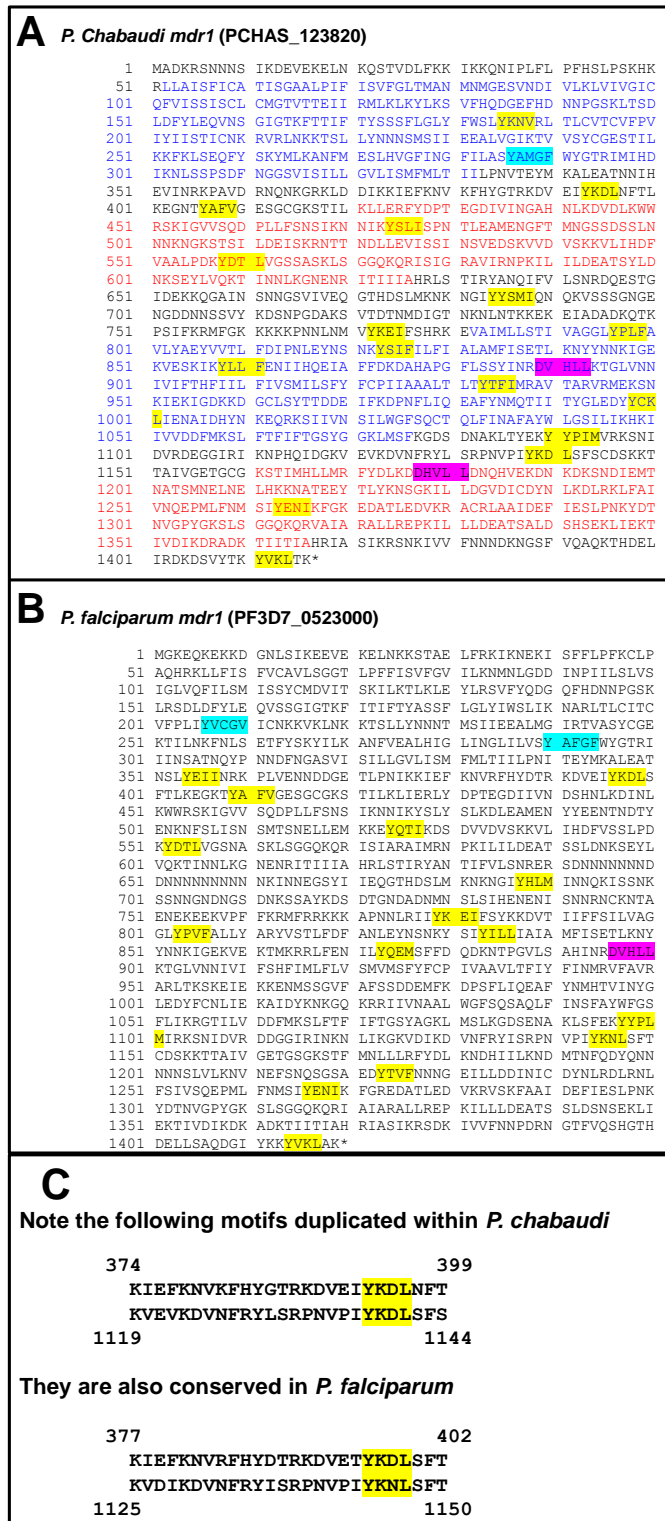

**Figure 6.** *P. chabaudi* and *P. falciparum mdr1* amino acid sequences with YXXG $\phi$  motifs. Protein sequences **A** *P. chabaudi*, **B**, *P. falciparum*. YXXF motifs (yellow), YXXGF non-canonical motifs (blue). DXXLL motifs binding to different adaptor chain (purple). Blue text, approximate extent of transmembrane domains; red text, approximate extent of predicted ABC (ATP binding cassettes) regions; **C**, similar conserved duplicated motifs in *P. chabaudi* (top) and *P. falciparum* (bottom). [The experimental work contributing to this figure was done by Pedro Cravo and Paul Hunt].

### Polymorphisms in *Plasmodium falciparum* *ap2-mu* gene

Because the only confirmed point mutation arising in *P. chabaudi* AS-ART along with ART resistance phenotype 2 lies in the *AP2-mu* gene, the polymorphisms in the *P. falciparum* orthologue (PF3D7\_1218300) were investigated. The DNA sequence analysis of PF3D7\_1218300 in 24 samples (see Table 2) from Brazil, São Tomé and Rwanda revealed a total of 12 independent polymorphic sites, consisting of nine SNPs and three indels. Seven SNPs and all the insertions were novel genetic variants (relative to existing information in PlasmoDB, Table 10) and unrelated to each other. A polymorphism similar to *P. chabaudi* I568T was not detected in any of the isolates inspected.

**Table 10.** Genetic polymorphisms identified in the *pfap2-mu* gene (PF3D7\_1218300).

Nucleotide	Reference	Codon, variant	Amino acid substitution	Location
	sequence (3D7) variant			
300	ATA	ATC	I100syn	Rwanda
381	G <u>T</u> G	G <u>T</u> I*/G <u>T</u> C	V127syn	Brazil
<b>437</b>	A <u>G</u> A	A <u>A</u> A	<b>R146K</b>	Rwanda
<b>479</b>	A <u>G</u> T	A <u>A</u> T	<b>S160N</b>	Rwanda, ST
486	A <u>T</u> T	A <u>T</u> C	I162syn	Rwanda
489	G <u>A</u> A	G <u>A</u> G*	E163syn	Rwanda, ST
<b>596</b>	A <u>A</u> A	A <u>C</u> A	<b>K199T</b>	Rwanda
<b>699</b>	A <u>A</u> T	A <u>A</u> G	<b>N233K</b>	Rwanda
<b>1311</b>	T <u>T</u> C	T <u>T</u> A	<b>F437L</b>	Rwanda
<b>Insertions</b>				
		<b>Codon insertion</b>	<b>Amino acid insertion</b>	
<b>699</b>	AAT	AATA <u>A</u> T	<b>233 + N</b>	ST
<b>972</b>	AAT	AATA <u>A</u> T	<b>324 + N</b>	Rwanda, ST
<b>987</b>	AAT	AATA <u>A</u> T	<b>329 + N</b>	ST

Polymorphic bases are underlined. \*- SNP previously identified and recorded in PlasmoDB. Non-synonymous SNPs are shown with amino acid substitutions (bold). ST, São Tomé.

Five of the nine SNPs were non-synonymous (aa 146, 160, 199, 233 and 437) while four were synonymous (Table 10). The non-synonymous mutations R146K, S160N and F437L

occur within regions which appear to be well conserved in *Plasmodium* spp of the N-terminal domain of *AP2-mu*, although residues in these regions are not well-conserved relative to the rat homologue (data not shown). The non-synonymous SNPs, K199T and N233K are situated in unconserved regions (data not shown).

The three indels were three-nucleotide insertions of an asparagine amino acid were found adjacent to codon 233, 324 or 329 in an asparagine-rich sequence (Table 10) not conserved in the *P. chabaudi* orthologue. Amino acids 324 and 329 are located on a *P. falciparum*-specific region relative to both *P. chabaudi* and the rat homologue (data not shown).

### Correlation of *in vitro* susceptibility to artemisinin derivatives and S160N polymorphism in *Plasmodium falciparum* isolates

We investigated possible associations between the AP2-mu S160N polymorphism and the previously reported [41, 42] *in vitro* ART-derivative response in Rwanda and São Tomé (Table 11, Figure 7).

**Table 11.** Frequency distribution of *pfap2-mu* alleles among *P. falciparum* samples from Brazil, São Tomé and Rwanda.

<i>pfap2-mu</i> allele	Brazil (N=56)	São Tomé (N=51)	Rwanda (N=73)
<b>Wild-type (S)</b>	N = 56 (100%)	N = 44 (86.2%)	N = 61 (83.6%)
<b>Mutant (N)</b>	N = 0 (0%)	N = 6 (11.8%)	N = 9 (12.3%)
<b>Mixed (S + N)</b>	N = 0 (0%)	N = 1 (2.0%)	N = 3 (4.1%)

The prevalence of the 160N allele was investigated in 180 isolates; 56 from Brazil [43], 51 from São Tomé [42] and 73 from Rwanda [41]. The frequency of the 160N genetic variant was ~12% in both African sites and absent in the Brazilian samples (Table 11).

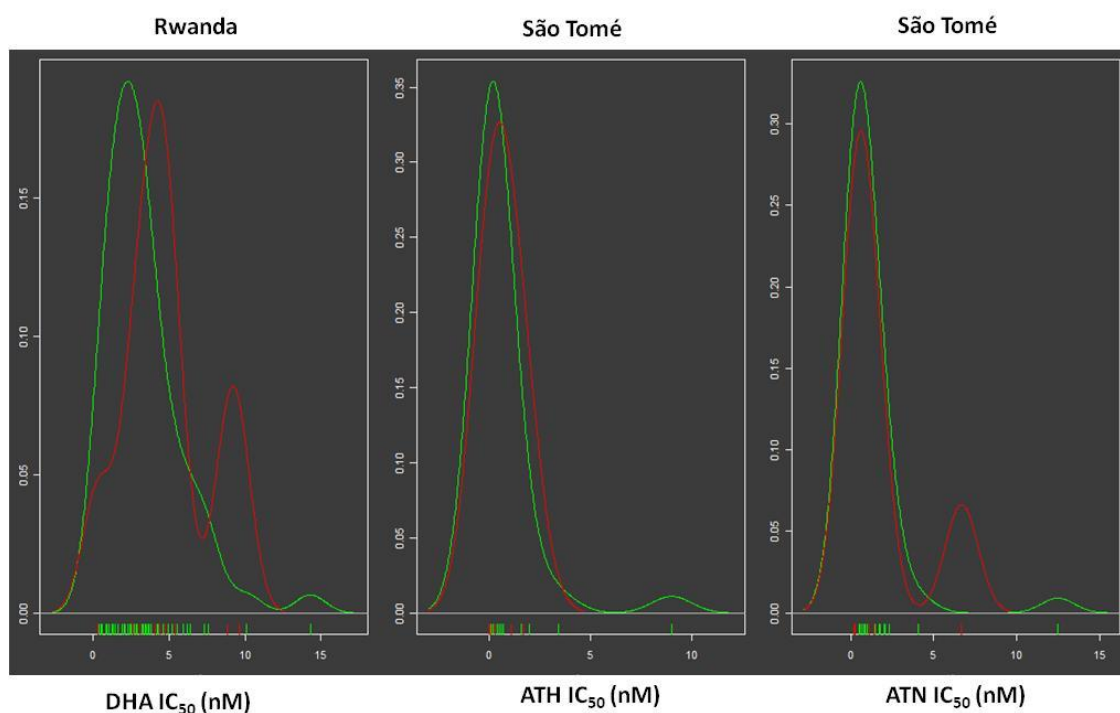

**Figure 7:** Density function curves for the WT (N160 *pfap2-mu*) (in green) and MUT (160S *pfap2-mu*) samples (in red). The ticks below the curves illustrate the measured  $IC_{50}$  values for each sample. DHA: dihydroartemisinin; ATN: artesunate; ATH: artemether.

ART response data were log-transformed and an ‘outlier’ identified and removed from the dataset as described in Methods. Comparison of mutant vs. wild-type log-transformed datasets revealed a significant difference between the mean  $IC_{50}$  values registered for genotypes 160S ( $4.86 \pm 0.07$  nM) and 160N ( $2.49 \pm 0.04$  nM) in parasites from Rwanda ( $p$ -value = 0.026, Table 4). This difference could also be observed in the function curves (shift to higher  $IC_{50}$  values) in the parasites from Rwanda (Figure 7). No significant differences were identified for parasites from São Tomé (Table 12).

**Table 12.** Average log ( $IC_{50}$ ) values (nM)  $\pm$  correspondent standard error and the associated t-test  $p$ -value for mutant and wild-type samples. The values in bold represent the average  $IC_{50}$  without log transformation

	Rwanda- DHA	São Tomé- ATN	São Tomé- ATH
<b>Mutant</b> (160S <i>pfap2-mu</i> )	0.687 ( <b>4.86</b> ) $\pm$ 0.0701 (N=8)	-0.670 ( <b>0.512</b> ) $\pm$ 0.383 (N=5)	-0.122 ( <b>0.885</b> ) $\pm$ 0.235 (N=6)
<b>Wild-type</b> (N160 <i>pfap2-mu</i> )	0.396 ( <b>2.49</b> ) $\pm$ 0.0450 (N=61)	-0.909 ( <b>0.403</b> ) $\pm$ 0.120 (N=36)	-0.232 ( <b>0.793</b> ) $\pm$ 0.0649 (N=44)
<b>p-value</b>	0.0256	0.500	0.580

DHA: dihydroartemisinin; ATN: artesunate; ATH: artemether

## Discussion

### Increased artemisinin resistance phenotype

An ART resistance phenotype (phenotype 1) in *P. chabaudi* was previously described and the underlying genetic mechanism (mutations in *ubp1*) identified [30]. That phenotype had been experimentally evolved in AS-30CQ under chloroquine selection and without any exposure to ART. Subsequently AS-ART was evolved from AS-30CQ by ART selection [25]. Here, an increased artemisinin resistance (phenotype 2) in AS-ART relative to AS-30CQ is characterized. The increased resistance is apparent at 200 mg ART kg<sup>-1</sup> d<sup>-1</sup> (inoculation of 10<sup>6</sup> parasites, three-day drug treatment). Interestingly a five-day treatment using a higher inoculum (10<sup>7</sup> parasites) also differentiated AS-ART from AS-30CQ. These data are consistent with the hypothesis that quiescence or dormancy responses may underlie survival of artemisinin treatment [58,59].

### Genetic basis of increased artemisinin resistance

Illumina whole-genome sequencing reveals a single point mutation arising between AS-30CQ and AS-ART. This mutation encodes an I568T substitution in the  $\mu$  subunit of the AP2 adaptor complex (PCHAS\_143590). The number of false negatives due to insufficient coverage is estimated to be less than one/genome, as previously discussed [30,31] and given the minimum threshold for point mutation detection (three reads), the proportion of the genome covered by less than three reads (1.67%, see Table 7) and the accurate identification of simulated mutations (random alterations in reference sequence) [30]. The frequency of a false negative arising from incorrect read alignment is minimized because the re-sequenced and reference genomes are largely identical, and because optimal hashing-table algorithms were used. Importantly the likely appearance of only one point mutation is consistent with previous genome re-sequencing studies [31] that reveal a consistent set of a small number of point mutations, most of which confer drug-resistance phenotypes in other drug-resistant clones of the *P. chabaudi* AS lineage (Table 1) [30-33]. For example, four or five out of seven single nucleotide substitutions between AS-sens and AS-30CQ confer resistance to pyrimethamine, chloroquine and artemisinin phenotype 1 [30,31]. This is consistent with similar studies using other parasites; for example, only four non-synonymous mutations arose in each of two miltefosine-selected *Leishmania major* genomes [60].

Although the possibility that increased ART-R is conferred by unidentified point mutations in the small fraction of the unassembled genome cannot be excluded, regions of low read coverage, the indel identified in AS-ART, or further unidentified indels, suggest that the mutation I568T in *AP2-mu* on chr14 is the principal determinant of higher-level artemisinin resistance (ART-R phenotype 2) in AS-ART which also bears the *ubp1* mutation [30] but no *mdr1* amplification [32]. This hypothesis should be validated by transfection experiments.

Other results are consistent with this hypothesis. A previous study suggested that a *locus* on chr14 contributes to artemisinin responses in genetic selection experiments using AS-ART [23]. Also, two recent independent reports show evidence of the involvement of adaptor proteins in drug resistance phenotypes in other human parasites. A genome-wide RNAi target sequencing approach revealed *Trypanosoma brucei* parasites with a knockdown of one of each of the four AP1 adaptor subunit genes (as well as lysosomal proteases, vacuolar protein sorting factors, etc.) of the endosomal system in suramin-treated populations [61]. In a similar experimental paradigm to that described here, an *in vitro* miltefosine-resistant *L. major* line bore a D762 mutation in the  $\alpha$ -subunit of an adaptor protein and a different mutation in the *Leishmania infantum* orthologue [60]. The probability that mutations in adaptor subunits confer resistance to three structurally and functionally unrelated drugs (suramin, miltefosine and artemisinin) in three different parasites (*Trypanosoma*, *Leishmania* and *Plasmodium*) suggests that a conserved aspect of drug treatment and response is targeted by these mutations.

### **Clathrin-mediated endocytosis - insights regarding ART action and resistance**

The AP2 adaptor complex is a heterotetramer ( $\alpha$ ,  $\beta$ ,  $\mu$ ,  $\sigma$ ) that selects and recruits other factors, including membrane protein (cargo) and intracellular clathrin, mediating clathrin-mediated endocytosis (CME) [46]. CME is involved in the internalization of extracellular molecules and ligands (e.g., low density lipoprotein, transferrin, growth factors, antibodies and bacterial toxins), the remodelling of the plasma membrane (removal of variable antigen), and membrane protein trafficking and vesicular sorting through the endosomal system and lysosomes [50]. In *P. falciparum*, these cellular processes are being studied particularly regarding digestive vacuole genesis, haemoglobin uptake and digestion [62], the role of (poly)phosphorylated phosphatidylinositol [63], the action of aminoquinolines and artemisinins [6,7,64-66] and the trafficking of a critical determinant of chloroquine



resistance (the membrane protein, *crt*) [67]. The participation of clathrin (as coated vesicles) in endocytosis and its relationship to the formation of cystosomes has not been fully clarified and, in any case, the mechanism would require the production of vesicles with double membranes (parasitophorous vacuole and parasite membranes). Nevertheless, it is possible that some elements of CME have been recruited to the haemoglobin uptake mechanism. The existence of *Plasmodium*-specific additional sequence between the N- and C-terminal domains of the *AP2-mu* chain may reflect non-canonical functional attributes of the AP2 adaptor complex.

The I568T mutation in the AP2 mu-chain locates to a residue forming a hydrophobic pocket into which the  $\Phi$  residue of the YXX $\Phi$  recognition motif on the cargo proteins binds. This suggests that modulation of cargo trafficking may be the key event in this resistance pathway. The I568T mutation in *AP2-mu* may reduce its binding to membrane cargo and mediates artemisinin resistance phenotype 2 by reducing endocytosis or the recycling or trafficking of one or more membrane proteins. Previous work has shown that fluorescent artemisinin derivatives concentrate in neutral lipid bodies close to the digestive vacuole [5], suggesting that drug may be taken up by endocytosis. Artemisinin interacts with the endocytic and endosomal pathway. For example, it inhibits endocytosis [64] and haemoglobin uptake [7], resulting in the disruption of the DV membrane [6] and some derivatives may increase the accumulation of endocytic vesicles [6]. Also, artemisinin activity is dependent on haemoglobin digestion [7]. A reduction in haemoglobin uptake or digestion may therefore constitute a strategy for surviving exposures to short-lived artemisinins. The I568T mutation might therefore reduce the rate of haemoglobin uptake and hence the activation or action of artemisinin. Indeed, the reduced growth of AS-ART in relation to its sensitive progenitor AS-30CQ in absence of treatment (Figure 3A), indirectly supports this notion. The involvement of adaptor proteins in resistance to suramin, miltefosine and artemisinin in *Trypanosoma*, *Leishmania* [68,69] and *Plasmodium* however, may suggest a rather general resistance mechanism involving, for example, the reduction of drug uptake through endocytosis.

A V2728F mutation in *ubp1* was previously identified as the critical determinant of artemisinin resistance phenotype 1 in AS-30CQ [30], predicting that this mutation would decrease de-ubiquitination. The ubiquitination of membrane receptors and proteins may induce clathrin-independent (caveolae) endocytosis [70]. Therefore, the *ubp1* and *AP2-mu* mutations may both modulate endocytosis, possibly changing the balance of endocytosis toward a clathrin-independent pathway. Interestingly, chloroquine is also known to

interact with endocytosis, vesicular transport, haemoglobin digestion and actin and DV dynamics [64-66,71] and the V2728F *ubp1* mutation has been shown to confer high-level CQ-resistance [31]. This artemisinin- and chloroquine-cross resistance is therefore consistent with the suggestion that endocytic pathways are involved in the mode of action of both of these drugs and the resistance mechanisms in *P. chabaudi*.

In addition, a number of observations are consistent with the view that *mdr1* could be a critical cargo protein. Firstly, *mdr1* duplication has been identified as another determinant of ART-R [32]. Secondly, *mdr1* sequences (both *P. chabaudi* and *P. falciparum*) contain many YXXΦ recognition motifs (Figure 6), suggesting that its trafficking and localization may be subject to control by the μ-adaptor. Thirdly, changes in the clathrin-dependent endocytosis and trafficking of *mdr1*-encoded P-glycoprotein (in human cancer cell lines) alter both its partition between cell membrane and intracellular pools, as well as the level of drug resistance [72]. Finally, distributions of P-glycoprotein within cancer cells and their drug-resistance phenotypes are also mediated by ubiquitination [73].

The present study therefore suggests that experimental studies on the molecular interactions between ubiquitination pathways, endocytosis and artemisinin uptake and sensitivity may provide important insights regarding artemisinin action and resistance mechanisms.

### Field studies of *P. falciparum*

12 genetic polymorphisms (nine SNPs and three insertions) were identified in the *P. falciparum* orthologue (PF3D7\_1218300) in field samples from Rwanda, São Tomé and Brazil, one of which (S160N) was associated with previously published *in vitro* DHA responses in parasites from Rwanda ( $p = 0.026$ ). We cannot exclude the possibility that a different genetically linked gene may regulate the parasite's *in vitro* response to DHA, particularly since linkage disequilibrium in this region of the genome was not estimated in these samples. It has been suggested that modified *in vitro* assays may be required for improved estimation and sensitivity of responses to ART [74].

Association studies in locations in Southeast Asia where ART-R has been reported would be of particular interest. A recent linkage analysis of a *P. falciparum* genetic cross (HB3 x Dd2) revealed 3 loci linked to *in vitro* artemisinin responses; on chr05, chr12 and chr13 [24]. Marker C12M63 was the most highly linked marker on chr12. However, this marker maps over 1 Mbase downstream from PF3D7\_1218300 suggesting that a different gene

was involved in that study. A genome-wide analysis of genetic diversity in *P. falciparum* parasites from Asia, with different artemisinin responses mapped a possible genetic determinant to a region of chr13 [21]. However, no SNPs were identified in these genes that could be associated with the *in vivo* parasite's responses to ART. Recently however, the genotyping of *P. falciparum* isolates from Asia established associations between four SNPs (on chromosomes 10, 13 and 14) and both recent positive selection and parasite clearance phenotypes after artemisinin treatment [75]. However, the genes and regions where these SNPs lie are not linked to the *P. falciparum* orthologue of the AP2 mu-chain on chromosome 12, suggesting a different gene to that identified here is involved.

We note that all of the field samples analyzed here were collected before the official implementation of ACTs. Therefore, although baseline levels of ART responses vary considerably between isolates this variability may be more likely to arise from pre-existing genetic variation than from that selected by drug use. However, naturally occurring polymorphisms (such as S160N), with small drug response effects, may represent the first step on the pathway to full resistance. For example, those recombinant clones of the HB3 x Dd2 cross with the lowest ART responses were, indeed, those in which resistance was most easily selected [24].

Due to the relatively small number of samples analyzed and the fact that all the samples were collected before the official implementation of ACTs, further studies will therefore be required to fully evaluate the association between PF3D7\_1218300 polymorphisms and *in vitro* artemisinin responses in *P. falciparum* parasites.

## Conclusions

An increased artemisinin resistance phenotype in a lineage of *P. chabaudi* drug-resistant parasites was identified. Genome-wide re-sequencing identifies a single point mutation in a critical part of the AP2 adaptor mu-chain. This mutation is predicted to increase artemisinin resistance by modulating clathrin-mediated endocytosis. Analysis of the orthologous gene in *P. falciparum* field isolates demonstrates existing genetic variation in the human malaria parasite and a weak association between a polymorphism in *pfap2-mu* gene and *in vitro* artemisinin responses.

Lastly, the possibility was considered that mutations in a different gene(s) may play a role in responses to artemisinin derivatives in *P. falciparum*. However, further than assigning particular mutations to ART resistance phenotypes, it is suggested that a potentially novel biological pathway through which artemisinin resistance may occur may be involved.

## Competing interests

The authors declare that they have no competing interests.

## Authors' contributions

GH genotyped field samples. AM performed whole genome analysis. LR, KM, RF collected phenotype data. DH and PH modelled 3D structures. LR, KM, SB validated mutations. Ud'A, HT, CK provided materials. PC and PH supervised study, interpreted data, and wrote the paper. All authors read and approved the final manuscript.

## Acknowledgements

Research was supported by Medical Research Council (MRC), UK (G0400476) and Fundação para a Ciência e a Tecnologia (FCT), Portugal (PTDC/SAU-MII/65028/2006). For personal support, we thank Centro de Malária & Doenças Tropicais.LA/IHMT Universidade Nova de Lisboa (PC), CAPES/PVE of Brazil (PC), FCT (AM, GH, LR, SB), Scottish Enterprise (DH), the Darwin Trust (KM), MRC (RF, PH), Wellcome Trust (PH) and School of Biological Science, University of Edinburgh (PH). GH, AM, LR and STB were each supported by the Fundação para a Ciência e a Tecnologia (FCT) of Portugal (grant numbers SFRH/BD/63129/2009, SRFH/BPD/35017/2007, SFRH/BD/31518/2006 and SFRH/BD/25096/2005, respectively). DNA sequencing was carried out in the GenePool Genomics Facility in the University of Edinburgh and we thank Marian Thomson, Karim Gharbi and other GenePool staff for assistance with sequencing. Members of the Pathogen Genomics group at the Wellcome Trust Sanger Institute and core sequencing and informatics groups gave valuable access to the *P. chabaudi* genome sequence, assembly and annotation data. We thank the staff of the following institutions for the *P. falciparum* samples used in this study: Centro Nacional de Endemias, São Tomé, Democratic Republic of São Tomé and Príncipe, Secretaria de Vigilância em Saúde, Instituto Evandro Chagas, Belém, Pará, Brazil and the National Malaria Control Program, Kigali, Rwanda. Artemisinin was a kind gift from Dafra Pharma.

## References

1. Hyde JE: **Drug-resistant malaria-an insight.** *FEBS J* 2007, **274**:4688–4698.
2. Maude RJ, Woodrow CJ, White LJ: **Artemisinin antimalarials: preserving the "magic bullet".** *Drug Dev Res* 2010, **71**:12–19.
3. O'Neill PM, Barton VE, Ward SA: **The molecular mechanism of action of artemisinin-the debate continues.** *Molecules* 2010, **15**:1705–1721.
4. Ding XC, Beck HP, Raso G: **Plasmodium sensitivity to artemisinins: magic bullets hit elusive targets.** *Trends Parasitol* 2011, **27**:73–81.
5. Hartwig CL, Rosenthal AS, D'Angelo J, Griffin CE, Posner GH, Cooper RA: **Accumulation of artemisinin trioxane derivatives within neutral lipids of *Plasmodium falciparum* malaria parasites is endoperoxide-dependent.** *Biochem Pharmacol* 2009, **77**:322–336.
6. del Pilar CM, Avery TD, Hanssen E, Fox E, Robinson TV, Valente P, Taylor DK, Tilley L: **Artemisinin and a series of novel endoperoxide antimalarials exert early effects on digestive vacuole morphology.** *Antimicrob Agents Chemother* 2008, **2008**(52):98–109.
7. Klonis N, Crespo-Ortiz MP, Bottova I, Abu-Bakar N, Kenny S, Rosenthal PJ, Tilley L: **Artemisinin activity against *Plasmodium falciparum* requires haemoglobin uptake and digestion.** *Proc Natl Acad Sci USA* 2011, **108**:11405–11410.
8. Eckstein-Ludwig U, Webb RJ, Van Goethem ID, East JM, Lee AG, Kimura M, O'Neill PM, Bray PG, Ward SA, Krishna S: **Artemisinins target the SERCA of *Plasmodium falciparum*.** *Nature* 2003, **424**:957–961.
9. Noedl H, Se Y, Schaecher K, Smith BL, Socheat D, Fukuda MM: **Artemisinin Resistance in Cambodia 1 (ARC1) Study Consortium: Evidence of artemisinin-resistant malaria in western Cambodia.** *N Engl J Med* 2008, **359**:2619–2620.
10. Dondorp AM, Nosten F, Yi P, Das D, Phyo AP, Tarning J, Lwin KM, Arie F, Hanpithakpong W, Lee SJ, Ringwald P, Silamut K, Imwong M, Chotivanich K, Lim P, Herdman T, An SS, Yeung S, Singhasivanon P, Day NPJ, Lindegardh N, Socheat D, White NJ: **Artemisinin resistance in *Plasmodium falciparum* malaria.** *N Engl J Med* 2009, **361**:455–467.
11. Lim P, Alker AP, Khim N, Shah NK, Incardona S, Doung S, Yi P, Bouth DM, Bouchier C, Puijalon OM, Meshnick SR, Wongsrichanalai C, Fandeur T, Le Bras J, Ringwald P, Arie F: ***Pfmdr1* copy number and artemisinin derivatives combination therapy failure in *falciparum* malaria in Cambodia.** *Malar J* 2009, **8**:11.
12. Noedl H, Socheat D, Satimai W: **Artemisinin-resistant malaria in Asia.** *N Engl J Med* 2009, **361**:540–541.
13. Rogers WO, Sem R, Tero T, Chim P, Lim PS, Socheat D, Arie F, Wongsrichanalai C: **Failure of artesunate-mefloquine combination therapy for uncomplicated *Plasmodium falciparum* malaria in southern Cambodia.** *Malar J* 2009, **8**:10.
14. Phyo AP, Nkhoma S, Stepniewska K, Ashley EA, Nair S, McGready R, Ler Moo C, Al-Saai S, Dondorp AM, Lwin KM, Singhasivanon P, Day NP, White NJ, Anderson TJ, Nosten F: **Emergence of artemisinin-resistant malaria on the western border of Thailand: a longitudinal study.** *Lancet* 2012, **379**:1960–1966.
15. Jambou R, Legrand E, Niang M, Khim N, Lim P, Volney B, Ekala MT, Bouchier C, Esterre P, Fandeur T, Mercereau-Puijalon OS: **Resistance of *Plasmodium falciparum* field isolates**

- to *in-vitro* artemether and point mutations of the SERCA-type PfATPase6. *Lancet* 2005, **366**:1960–1963.
16. Uhlemann A-C, Cameron A, Eckstein-Ludwig U, Fischbarg J, Iserovich P, Zuniga FA, East M, Lee A, Brady L, Haynes RK, Krishna S: **A single amino acid can determine sensitivity of SERCAs to artemisinins.** *Nat Struct Mol Biol* 2005, **12**:628–629.
17. Reed MB, Saliba KJ, Caruana SR, Kirk K, Cowman AF: **Pgh1 modulates sensitivity and resistance to multiple antimalarials in *Plasmodium falciparum*.** *Nature* 2000, **403**:906–909.
18. Price RN, Uhlemann AC, Brockman A, McGready R, Ashley E, Phaipun L, Patel R, Laing K, Looareesuwan S, White NJ, Nosten F, Krishna S: **Mefloquine resistance in *Plasmodium falciparum* and increased *pfmdr1* gene copy number.** *Lancet* 2004, **364**:438–447.
19. Sidhu ABS, Uhlemann A-C, Valderramos SG, Valderramos J-C, Krishna S, Fidock DA: **Decreasing *pfmdr1* copy number in *Plasmodium falciparum* malaria heightens susceptibility to mefloquine, lumefantrine, halofantrine, quinine, and artemisinin.** *J Infect Dis* 2006, **194**:528–535.
20. Imwong M, Dondorp AM, Nosten F, Yi P, Mungthin M, Hanchana S, Das D, Phyto AP, Lwin KM, Pukrittayakamee S, Lee SJ, Saisung S, Koecharoen K, Nguon C, Day NP, Socheat D, White NJ: **Exploring the contribution of candidate genes to artemisinin resistance in *Plasmodium falciparum*.** *Antimicrob Agents Chemother* 2010, **54**:2886–2892.
21. Cheeseman IH, Miller BA, Nair S, Nkhoma S, Tan A, Tan JC, Al Saai S, Phyto AP, Moo CL, Lwin KM, McGready R, Ashley E, Imwong M, Stepniewska K, Yi P, Dondorp AM, Mayxay M, Newton PN, White NJ, Nosten F, Ferdig MT, Anderson TJ: **A major genome region underlying artemisinin resistance in malaria.** *Science* 2012, **336**:79–82.
22. Chavchich M, Gerena L, Peters J, Chen N, Cheng Q, Kyle DE: **Induction of resistance to artemisinin derivatives in *Plasmodium falciparum*: Role of *Pfmdr1* amplification and expression.** *Antimicrob Agent Chemother* 2010, **54**:2455–2464.
23. Hunt P, Afonso A, Creasey A, Culleton R, Sidhu AB, Logan J, Valderramos SG, McNae I, Cheesman S, Do Rosario V, Carter R, Fidock DA, Cravo P: **Gene encoding a deubiquitinating enzyme is mutated in artesunate- and chloroquine-resistant rodent malaria parasites.** *Mol Microbiol* 2007, **65**:27–40.
24. Beez D, Sanchez CP, Stein WD, Lanzer M: **Genetic predisposition favors the acquisition of stable artemisinin resistance in malaria parasites.** *Antimicrob Agents Chemother* 2011, **55**:50–55.
25. Afonso A, Hunt P, Cheesman S, Alves AC, Cunha CV, Do Rosário V, Cravo P: **Malaria parasites can develop stable resistance to artemisinin but lack mutations in candidate genes *atp6* (encoding the sarcoplasmic and endoplasmic reticulum Ca<sup>2+</sup> ATPase), *tctp*, *mdr1* and *cg10*.** *Antimicrob Agents Chemother* 2006, **50**:480–489.
26. Walliker D, Carter R, Sanderson A: **Genetic studies on *Plasmodium chabaudi*: recombination between enzyme markers.** *Parasitology* 1975, **70**:19–24.
27. Rosario VE: **Genetics of chloroquine resistance in malaria parasites.** *Nature* 1976, **261**:585–586.
28. Padua RA: ***Plasmodium chabaudi*: genetics of resistance to chloroquine.** *Exp Parasitol* 1981, **52**:419–426.

29. Cravo PVL, Carlton JM-R, Hunt P, Bisoni L, Padua RA, Walliker D: **Genetics of mefloquine resistance in the rodent malaria *Plasmodium chabaudi***. *Antimicrob Agents Chemother* 2003, **47**:709–718.
30. Hunt P, Martinelli A, Borges S, Modrzynska K, Creasey A, Rodrigues L, Beraldi D, Loewe L, Kumar S, Thomson M, Urmi T, Otto T, Pain A, Blaxter M, Cravo P: **Experimental evolution, genetic analysis and genome re-sequencing reveals the mutation conferring artemisinin resistance in an isogenic lineage of malaria parasites**. *BMC Genomics* 2010, **11**:499.
31. Modrzynska K, Creasey A, Loewe L, Cezard T, Borges S, Martinelli A, Rodrigues L, Cravo P, Blaxter M, Carter R, Hunt P: **Quantitative genome re-sequencing defines multiple mutations conferring chloroquine resistance in rodent malaria**. *BMC Genomics* 2012, **13**:106.
32. Borges S, Cravo P, Creasey A, Fawcett R, Modrzynska K, Rodrigues L, Martinelli A, Hunt P: **Genomewide scan reveals amplification of *mdr1* as a common denominator of resistance to mefloquine, lumefantrine, and artemisinin in *Plasmodium chabaudi* malaria parasites**. *Antimicrob Agents Chemother* 2011, **55**:4858–4865.
33. Martinelli A, Henriques G, Cravo P, Hunt P: **Whole genome resequencing identifies a mutation in an ABC transporter (*mdr2*) in a *Plasmodium chabaudi* clone with altered sensitivity to antifolate drugs**. *Int J Parasitol* 2011, **41**:165–171.
34. Carlton JM, Hayton K, Cravo PV, Walliker D: **Of mice and malaria mutants: unravelling the genetics of drug resistance using rodent malaria models**. *Trends Parasitol* 2001, **17**:236–242.
35. Grech K, Martinelli A, Pathirana S, Walliker D, Hunt P, Carter R: **Numerous, robust genetic markers for *Plasmodium chabaudi* by the method of amplified fragment length polymorphism**. *Mol Biochem Parasitol* 2002, **123**:95–104.
36. : Wellcome Trust Sanger Institute.. Index of <ftp://ftp.sanger.ac.uk/>. [ftp://ftp.sanger.ac.uk/pub/pathogens/P\\_chabaudi/September\\_2009\\_assembly](ftp://ftp.sanger.ac.uk/pub/pathogens/P_chabaudi/September_2009_assembly).
37. Li H, Ruan J, Durbin R: **Mapping short DNA sequencing reads and calling variants using mapping quality scores**. *Genome Res* 2008, **18**:1851–1858.
38. Ning Z, Cox AJ, Mullikin JC: **SSAHA: a fast search method for large DNA databases**. *Genome Res* 2001, **11**:1725–1729.
39. Li H, Handsaker B, Wysoker A, Fennell T, Ruan J, Homer N, Marth G, Abecasis G, Durbin R: **1000 Genome Project Data Processing Subgroup: The Sequence alignment/map (SAM) format and SAMtools**. *Bioinformatics* 2009, **25**:2078–2079.
40. Ambrish R, Alper K, Yang Z: **I-TASSER: a unified platform for automated protein structure and function prediction**. *Nat Prot* 2010, **5**:725–738.
41. Tinto H, Rwagacondo C, Karema C, Mupfasoni D, Vandoren W, Rusanganwa E, Erhart A, Van Overmeir C, Van Marck E, D'Alessandro U: **In-vitro susceptibility of *Plasmodium falciparum* to monodesethylamodiaquine, dihydroartemisinin and quinine in an area of high chloroquine resistance in Rwanda**. *Trans R Soc Trop Med Hyg* 2006, **100**:509–514.
42. Ferreira ID, Lopes D, Martinelli A, Ferreira C, Do Rosário VE, Cravo P: **In vitro assessment of artesunate, artemether and amodiaquine susceptibility and molecular analysis of putative resistance-associated mutations of *Plasmodium falciparum* from São Tomé & Príncipe**. *Trop Med Int Health* 2007, **12**:353–362.

43. Ferreira ID, Martinelli A, Rodrigues LA, Do Carmo EL, Do Rosário VE, Povoá MM, Cravo P: ***Plasmodium falciparum* from Pará state (Brazil) shows satisfactory *in vitro* response to artemisinin derivatives and absence of the S769N mutation in the SERCA-type PfATPase6.** *Trop Med Int Health* 2008, **13**:199–207.
44. Plowe CV, Djimde A, Bouare M, Doumbo O, Wellem TE: **Pyrimethamine and proguanil resistance-conferring mutations in *Plasmodium falciparum* dihydrofolate reductase: polymerase chain reaction methods for surveillance in Africa.** *Am J Trop Med Hyg* 1995, **52**:565–568.
45. D'Agostino R, Pearson E: **Tests for departures from normality. Empirical results for the distribution of  $v_{b1}$  and  $b_2$ .** *Biometrika* 1973, **60**: 613–622.
46. Traub LM: **Tickets to ride: selecting cargo for clathrin-regulated internalisation.** *Nat Rev Mol Cell Biol* 2009, **10**:583–596.
47. Brandström M, Ellegren H: **The genomic landscape of short insertion and deletion polymorphisms in the chicken (*Gallus gallus*) Genome: a high frequency of deletions in tandem duplicates.** *Genetics* 2007, **176**:1691–1701.
48. Clark TG, Andrew T, Cooper GM, Margulies EH, Mullikin JC, Balding DJ: **Functional constraint and small insertions and deletions in the ENCODE regions of the human genome.** *Genome Biol* 2007, **8**:R180.
49. 1000 Genomes Project Consortium: **A map of human genome variation from population-scale sequencing.** *Nature* 2010, **467**:1061–1073.
50. Bonifacino JS, Traub LM: **Signals for sorting of transmembrane proteins to endosomes and lysosomes.** *Annu Rev Biochem* 2003, **72**:395–447.
51. Olusanya O, Andrews PD, Swedlow JR, Smythe E: **Phosphorylation of threonine 156 of the  $\mu 2$  subunit of AP2 complex is essential for endocytosis *in vitro* and *in vivo*.** *Curr Biol* 2001, **11**:896–900.
52. Collins BM, McCoy AJ, Kent HM, Evans PR, Owen DJ: **Molecular Architecture and functional model of the endocytic AP2 complex.** *Cell* 2002, **109**:523–535.
53. Jackson LP, Kelly BT, McCoy AJ, Gaffry T, James LC, Collins BM, Höning S, Evans PR, Owen DJ: **A large-scale conformational change couples membrane recruitment to cargo binding in the AP2 clathrin adaptor complex.** *Cell* 2010, **141**:1220–1229.
54. Owen DJ, Collins BM, Evans PR: **Adaptors for clathrin coats: structure and function.** *Ann Rev Cell Dev Biol* 2004, **20**:153–191.
55. Heung KM, D'Hondt K, Riezman H, Lemmon SK: **Clathrin functions in the absence of heterotetrameric adaptors and AP180-related proteins in yeast.** *EMBO J* 1999, **18**:3897–3908.
56. Yeung BG, Phan HL, Payne GS: **Adaptor complex-independent clathrin function in yeast.** *Mol Biol Cell* 1999, **10**:3643–3659.
57. Koenderink JB, Kavishe RA, Rijpma SR, Russel FG: **The ABCs of multidrug resistance in malaria.** *Trends Parasitol* 2010, **26** (9):440–6
58. Teuscher F, Gatton ML, Chen N, Peters J, Kyle DE, Cheng Q: **Artemisinin-induced dormancy in *Plasmodium falciparum*: duration, recovery rates, and implications in treatment failure.** *J Infect Dis* 2010, **202**:1362–1368.
59. Witkowski B, Lelievre J, Barragan MJL, Laurent V, Su X-Z, Berry A, Francoise B: **Increased tolerance to artemisinin in *Plasmodium falciparum* is mediated by a quiescence mechanism.** *Antimicrob Agents Chemother* 2010, **54**:1872–1877.



60. Coelho AC, Boisvert S, Mukherjee A, Leprohon P, Corbeil J, Ouellette M: **Multiple mutations in heterogeneous miltefosine-resistant *Leishmania major* population as determined by whole genome sequencing.** *PLoS Negl Trop Dis* 2012, **6**:e1512.
61. Alford S, Eckert S, Baker N, Glover L, Sanchez-Flores A, Leung KF, Turner DJ, Field MC, Berriman M, Horn D: **High-throughput decoding of antitrypanosomal drug efficacy and resistance.** *Nature* 2012, **482**:232–236.
62. Abu-Bakar N, Klonis N, Hanssen E, Chan C, Tilley L: **Digestive-vacuole genesis and endocytic processes in the early intraerythrocytic stages of *Plasmodium falciparum*.** *J Cell Sci* 2010, **123**:441–550.
63. Vaid A, Ranjan R, Smythe WA, Hoppe HC, Sharma P: **PfPI3K, a phosphatidylinositol-3 kinase from *Plasmodium falciparum*, is exported to the host erythrocyte and is involved in haemoglobin trafficking.** *Blood* 2010, **115**:2500–2507.
64. Hoppe HC, van Schalkwyk DA, Wiehart UIM, Meredith SA, Egan J, Weber BW: **Antimalarial quinolines and artemisinin inhibit endocytosis in *Plasmodium falciparum*.** *Antimicrob Agents Chemother* 2004, **48**:2370–2378.
65. Roberts L, Egan TJ, Joiner KA, Hoppe HC: **Differential effects of quinoline antimalarials on endocytosis in *Plasmodium falciparum*.** *Antimicrob Agents Chemother* 2008, **52**:1840–1842.
66. Feng TS, Guantai EM, Nell M, van Rensburg CEJ, Ncokazi K, Egan TJ, Hoppe HC, Chibale K: **Effects of highly active novel artemisinin-chloroquinoline hybrid compounds on @b-hematin formation, parasite morphology and endocytosis in *Plasmodium falciparum*.** *Biochem Pharmacol* 2011, **82**:236–247.
67. Kuhn Y, Sanchez CP, Ayoub D, Saridaki T, van Dorsselaer A, Lanzer M: **Trafficking of the phosphoprotein PfCRT to the digestive vacuolar membrane in *Plasmodium falciparum*.** *Traffic* 2010, **11**:236–249.
68. Vansterkenburg ELM, Coppens I, Wilting J, Bos OJM, Fischer MJE, Janssen LHM, Opperdoes FR: **The uptake of the trypanocidal drug suramin in combination with low-density lipoproteins by *Trypanosoma brucei* and its possible mode of action.** *Acta Trop* 1993, **54**:237–250.
69. Pal A, Hall BS, Field MC: **Evidence for a non-LDL-mediated entry route for the trypanocidal drug suramin in *Trypanosoma brucei*.** *Mol Biochem Parasitol* 2002, **122**:217–221.
70. Mukhopadhyay D, Riezman H: **Proteasome-independent functions of ubiquitin in endocytosis and signaling.** *Science* 2007, **315**:201–215.
71. Smythe WA, Joiner KA, Hoppe HC: **Actin is required for endocytic trafficking in the malaria parasite *Plasmodium falciparum*.** *Cell Microbiol* 2008, **10**:452–464.
72. Kim H, Barroso M, Samanta R, Greenberger L, Sztul E: **Experimentally induced changes in the endocytic traffic of P-glycoprotein alter drug resistance of cancer cells.** *Am J Physiol Cell Physiol* 1997, **273**: 687-702.
73. Zhang Z, Wu JY, Hait WN, Yang JM: **Regulation of the stability of P-glycoprotein by ubiquitination.** *Mol Pharmacol* 2004, **66**(3):395-403.
74. Valderramos SG, Scandfield D, Uhlemann AC, Fidock DA, Krishna S: **Investigations into the role of the *Plasmodium falciparum* SERCA (PfATP6) L263E mutation in artemisinin action and resistance.** *Antimicrob Ag Chemother* 2010, **54**(9):3842-52.
75. Takala-Harrison S, Clark TG, Jacob CG, Cummings MP, Miotto O, Dondorp AM, Fukuda MM, Nosten F, Noedl H, Imwong M, Bethell D, Se Y, Lon C, Tyner SD, Saunders DL, Socheat

D, Ariey F, Phyo AP, Starzengruber P, Fuehrer HP, Swoboda P, Stepniewska K, Flegg J, Arze C, Cerqueira GC, Silva JC, Ricklefs SM, Porcella SF, Stephens RM, Adams M, Kenefic LJ, Campino S, Auburn S, MaInnis B, Kwiatkowski DP, Su XZ, White NJ, Ringwald P, Plowe CV: **Genetic loci associated with delayed clearance of Plasmodium falciparum following artemisinin treatment in Southeast Asia.** *Proc Natl Acad Sci USA* 2013, **110**(1):240–245.

# Chapter 5

---

## **DIRECTIONAL SELECTION AT THE *PFMDR1*, *PFCRT*, *PFUBP1* AND *PFAP2-MU* LOCI OF *PLASMODIUM FALCIPARUM* IN KENYAN CHILDREN TREATED WITH ACT**

**This chapter is based on the following manuscript:** Henriques G., Hallett R.L., Beshir K.B., Gadalla N.B., Johnson R.E., Burrow R., van Schalkwyk D.A., Sawa P., Omar S.A., Clark T.G., Bousema T., Sutherland C.J. 2014. Directional selection at the *pfmdr1*, *pfcr1*, *pfubp1* and *pfap2-mu* loci of *Plasmodium falciparum* in Kenyan children treated with ACT. J Infect Dis. jiu358 first published online July 3, 2014 doi:10.1093/infdis/jiu358



Registry

T: +44(0)20 7299 4646  
F: +44(0)20 7299 4656  
E: registry@lshtm.ac.uk

**COVER SHEET FOR EACH 'RESEARCH PAPER' INCLUDED IN A RESEARCH THESIS**

Please be aware that one cover sheet must be completed for each 'Research Paper' included in a thesis.

**1. For a 'research paper' already published**

1.1. Where was the work published? Journal of Infectious Diseases

1.2. When was the work published? July 2014

1.2.1. If the work was published prior to registration for your research degree, give a brief rationale for its inclusion

1.3. Was the work subject to academic peer review? yes

1.4. Have you retained the copyright for the work? Yes / No

If yes, please attach evidence of retention.

If no, or if the work is being included in its published format, please attach evidence of permission from copyright holder (publisher or other author) to include work

**2. For a 'research paper' prepared for publication but not yet published**

2.1. Where is the work intended to be published? .....

2.2. Please list the paper's authors in the intended authorship order

2.3. Stage of publication – Not yet submitted / Submitted / Undergoing revision from peer reviewers' comments / In press

**3. For multi-authored work, give full details of your role in the research included in the paper and in the preparation of the paper. (Attach a further sheet if necessary)**

I genotyped plap2-mu gene and helped genotyping the plabp1 gene

NAME IN FULL (Block Capitals) GISELA CRISTINA LOURENÇO HENRIQUES

STUDENT ID NO: 298382

CANDIDATE'S SIGNATURE Gisela Henriques Date 27/08/2014

SUPERVISOR/SENIOR AUTHOR'S SIGNATURE (3 above) [Signature] 27/08/2014

## Evidence of permission to include the published work in the thesis:

### RE: Request

---

**From:** JOURNALS PERMISSIONS <Journals.Permissions@oup.com>  
**To:** Gisela.Henriques@lshtm.ac.uk  
**Date:** Wednesday - August 13, 2014 10:03 AM  
**Subject:** RE: Request  
**Attachments:** TEXT.htm; Mime.822

---

Dear Gisela,

Re: Gisela Henriques, Rachel L. Hallett, Khalid B. Beshir et al. Directional Selection at the *pfmdr1*, *pfprt*, *pfubp1*, and *pfap2mu* Loci of *Plasmodium falciparum* in Kenyan Children Treated With ACT *J Infect Dis.* **ju358** first published online July 3, 2014 doi:10.1093/infdis/jiu358

Thank you for your request. Please be advised that you are permitted to include 'a post print' of your article (accepted manuscript PDF) in your thesis and public availability outside your study institution should be delayed until 12 months after first online publication in the journal. Please include the following credit line:

*This is a pre-copy-editing, author-produced PDF of an article accepted for publication in [insert journal title] following peer review. The definitive publisher-authenticated version [insert complete citation information here] is available online at: xxxxxxx [insert URL that the author will receive upon publication here].*

For full details of the self-archiving policy for this journal please follow this link:

<http://www.oxfordjournals.org/en/access-purchase/rights-and-permissions/self-archiving-policya1.html>

Kind regards,  
Guffi

Guffi Chohdri (Ms)  
Rights Assistant  
Academic Rights & Journals  
Tel: +44 (0)1865 354454  
Email: [guffi.chohdri@oup.com](mailto:guffi.chohdri@oup.com)

This is a pre-copy-editing, author-produced PDF of an article accepted for publication in Journal of Infectious Diseases following peer review. The definitive publisher-authenticated version [Gisela Henriques, Rachel L. Hallett, Khalid B. Beshir et al. Directional Selection at the *pfmdr1*, *pfcr1*, *pfubp1*, and *pfap2-mu* Loci of *Plasmodium falciparum* in Kenyan Children Treated With ACT J Infect Dis. jiu358 first published online July 3, 2014 doi:10.1093/infdis/jiu358] is available online at: <http://jid.oxfordjournals.org/content/early/2014/07/28/infdis.jiu358.abstract?papetoc>

## ABSTRACT

### **Background**

The efficacy of ACT for *Plasmodium falciparum* malaria may be threatened by parasites with reduced responsiveness to artemisinins. Among 298 ACT-treated children from Mbita, Kenya, sub-microscopic persistence of *P. falciparum* on day 3 post-treatment was associated with subsequent microscopically detected parasitaemia at days 28 or 42.

### **Methods**

DNA sequences of resistance-associated parasite loci *pfcr1*, *pfmdr1*, *pfubp1* and *pfap2mu* were determined in the Mbita cohort before treatment, on days 2 and 3 after initiation of treatment and on the day of treatment failure.

### **Results**

Parasites surviving ACT on day 2 or day 3 post-treatment were significantly more likely than the baseline population to carry the wild type haplotypes of *pfcr1* (CVMNK at codons 72-76;  $P < 0.001$ ) and *pfmdr1* (NFD at codons 86, 184, 1246;  $P < 0.001$ ). In contrast, variant alleles of the novel candidate resistance genes *pfap2-mu* (S160N/T;  $P = 0.006$ ) and *pfubp-1* (E1528D;  $P < 0.001$ ) were significantly more prevalent post-treatment. No genetic similarities were found to artemisinin-tolerant parasites recently described in Cambodia.

### **Conclusions**

Among treated children in western Kenya, certain *P. falciparum* genotypes defined at *pfcr1*, *pfmdr1*, *pfap2-mu* and *pfubp1* more often survive ACT at sub-microscopic level, and contribute to onward transmission and subsequent patent recrudescence.

## INTRODUCTION

Over the last decade, the widespread deployment of artemisinin-based combination therapy (ACT), with improved vector control and other measures, has contributed to a reduction of malaria-related morbidity and mortality across sub-Saharan Africa [1, 2]. These public health gains may be lost if the efficacy of ACT against *Plasmodium falciparum* is not sustained. Recent evidence suggests that parasite genotypes have arisen in Cambodia and surrounding countries that are less rapidly cleared by artesunate monotherapy [3-6]. This has been interpreted by some as *bona fide* emerging artemisinin resistance [4, 6], and by others as “treatment failure”, with full-blown resistance to ACT not yet present [7]. The efficacy of ACT remains high in Africa, with no reports to date of slow clearance as in Cambodia. However, evidence based on classical microscopic parasite detection suggests that a proportion of ACT-treated children in Kenya do not completely clear *P. falciparum* parasitaemia [8]. More recently, qPCR-detectable sub-microscopic residual parasitaemia on day 2 or 3 post-ACT in Kenyan children was shown to be a significant risk factor for parasite transmission to mosquitoes, and for microscopically-detected parasitaemia recurring on day 28 or 42 [9]. Thus residual asexual parasitaemia, if genetically determined, may provide an enhanced likelihood of infecting the vector population, and thus further human hosts. Such evolutionary success, where parasites harbouring genetic markers of drug resistance exhibit a transmission advantage, has previously been implicated in the development of resistance to chloroquine and anti-folate malaria drugs [10-12].

The possibility that *P. falciparum* populations in Kenya may be less responsive to ACT therapy than previously reported provides a strong rationale for further investigation, for two reasons. Firstly, identification of any heritable genetic signature for this phenotype would enable monitoring of its spread by tracking relevant molecular markers. Secondly, it is important to determine whether the sub-microscopic persisting parasite phenotype described in Kenya is related to the more pronounced microscopically detectable slow clearance described from western Cambodia [3,4], given important differences in transmission intensity, population prevalence of acquired immunity and treatment policy. Genetic characterisation of the persisting Kenyan parasites at candidate loci known or suspected to be under selection by ACT would address both objectives. Candidate loci include, firstly, markers for resistance to the quinoline drugs chloroquine and amodiaquine, known to be selected by ACT towards quinoline-sensitive alleles [13-16]. Secondly, new candidates *pcubp1* (encoding ubiquitin carboxyl-terminal hydrolase 1) and *pcap2mu*



(encoding clathrin vesicle-associated adaptor 2,  $\mu$  subunit), both implicated in artemisinin resistance in the rodent parasite *P. chabaudi*, have been shown to have polymorphic homologues in *P. falciparum* [17-18]. These polymorphisms have yet to be fully validated as markers in parasites with reduced sensitivity to artemisinin derivatives *in vivo*. However, genome-wide association studies of *P. falciparum* isolates from coastal Kenya in which the *pfubp1* variant E1528D was associated with reduced susceptibility to artemisinin *in vitro* were recently reported [19].

To characterise any genetic signature of slow clearing sub-microscopic infections in ACT-treated children from Mbita, Kenya [9], *pfcr1*, *pfmdr1*, *pfubp1*, and *pfap2-mu* genotypes were determined on days 2 and 3, and on day of recrudescence in the case of later treatment failures. These were compared with pre-treatment parasite genotypes isolated from children at baseline, and evaluated for evidence of post-treatment selection *in vivo*.

## METHODS

### *Trial design and participants*

As previously described in detail [20], 298 children aged 6 months to 10 years were randomly allocated to receive a 6-dose regimen of artemether-lumefantrine (AL) or a 3-dose regimen of dihydroartemisinin-piperaquine (DP), fully observed, and followed for 42 days, according to a protocol approved by the KEMRI Scientific Steering Committee (#1556, 2009) and the LSHTM Ethics Committee (#5455, 2009). Detailed parasite clearance dynamics were assessed by qPCR as described elsewhere [9].

### *Detection of genetic polymorphisms in loci of interest*

Parasite DNA was extracted from ~10 $\mu$ L blood spots collected on Whatman filter paper prior to treatment (day 0) and on days 2, 3, 7, 14, 28 and 42 after treatment as previously described [9]. Polymorphisms in the *pfcr1* gene (PF3D7\_0709000), encoding the *P. falciparum* chloroquine resistance transporter, were determined in parasite DNA by multiplex qPCR as described [21]. Polymorphisms at codons 86, 184 and 1246 in the *pfmdr1* gene (PF3D7\_0523000), encoding P-glycoprotein H1, were identified using direct sequencing of PCR products as previously described with minor modifications [16].

Polymorphisms in the *pfap2-mu* gene (PF3D7\_1218300), encoding the  $\mu$ -subunit of clathrin-associated AP2 adaptor protein [18], were determined by PCR amplification and direct sequencing of three fragments encompassing codons 1-174, 121-399 and 377-621, as described [22].

Polymorphisms in *pfubp-1* (PF3D7\_0104300) in the 300bp region encompassing codons 1463 – 1563 were determined using a PCR strategy designed and optimised for this study. Nested PCR products were generated using the primer sets:

Nest 1 Forward Primer (pfubp1_1452_1F)	CGCCCGTACTATGAAGAAGATC
Nest 1 Reverse Primer (pfubp1_1612_1R)	GGCTTTTACCTGAACTGTTTCAGG
Nest 2 Forward Primer (pfubp1_1463_2F)	CGTAAACAGAATATTCAGGATTGC
Nest 2 Reverse Primer (pfubp1_1563_2R)	CTAGCCCTTTATTATCATTATCG

Amplification was performed with two nested reactions of 40 cycles of 3-step PCR, with 30s annealing at 53°C (nest 1) or 57°C (nest 2) and elongation at 72°C for 45s. Products were characterised by direct sequencing as described [22]. Ambiguous mixed haplotypes of *pfmdr1* were excluded from the analysis as previously described (14). Mixed genotypes were included in the analysis at the *pfcr1* locus, where only two haplotypes were found at codons 72-76, and at both the *pfap2-mu* and *pfubp1* loci, for which only a single variable codon was evaluated.

### ***Analysis of locus polymorphism in global P. falciparum genome data***

Single nucleotide polymorphic residues in the *pfap2-mu* and *pfubp1* loci were examined in Plasmoview (<http://pathogenseq.lshtm.ac.uk/plasmoview>) [23], in an ordered set of 631 *P. falciparum* genomes stratified by geographical region.

### ***Statistical analysis***

Binary variables were compared across pairs of categories, and odds ratios (OR) with 95% confidence intervals (CI) estimated. Significance was determined using the *chi*-squared distribution. Directional selection in paired samples from the same patient at different time-points was tested for statistical significance using McNemar's symmetry test. All analyses were performed in STATA 11 (Timberlake Associates, College Station, Texas).

## RESULTS

### ***Codons 72-76 of pfCRT***

The wild-type *pfCRT* allele, encoding CVMNK at codons 72 – 76 of the CRT protein, was confirmed as present in 143 of the 278 (51.4%) evaluable parasite isolates prior to treatment (day 0), of which 89 also harboured the CVIET allele. The remaining 135 isolates (48.6%) were CVIET alone. The CVMNK allele was significantly more common among sub-microscopic infections at day 3, being detected in 66 of the 73 successfully evaluated (90.4%; OR 8.90; 95% CI 3.88 - 23.7;  $P < 0.001$ ). A significant proportion on day 3 (68%) were mixed infections comprising both the CVMNK and CVIET genotypes. Thirty-five of the 65 children with detectable CVMNK parasites at day 3 did not carry this genotype at day 0, compared to only 3 children presenting with CVMNK but having only CVIET detected at day 3, demonstrating significant asymmetry, interpretable as strong directional within-host selection for the CVMNK allele ( $\chi^2 = 26.95$ , 1 d.f.;  $P < 0.001$ ). This effect remained significant after stratification for treatment group (Table 1). These findings suggest that in those children with both *pfCRT* genotypes present prior to treatment, CVMNK significantly increased in relative abundance from day 0 to day 3. There was evidence that carriage of CVMNK prior to treatment was associated with risk of parasite recurrence at day 28 or day 42 for AL (OR 2.461, 95% CI 1.004 – 6.23;  $P = 0.030$ ) but not for DP (OR 1.405, 95% CI 0.154 – 17.3;  $P = 0.714$ ).

**Table 1.** Prevalence of *pfcr1* and *pfmdr1* haplotypes before and after treatment with artemether-lumefantrine or dihydroartemisinin-piperaquine.

Gene	Treatment	Odds Ratio: occurrence on day 3	Directional selection within-host*		
		Vs baseline (95% CI)	LOSS (frequency)	GAIN (frequency)	P value
<i>pfcr1</i> codons 72-76 CVMNK	AL (N = 43, 143)	10.32 (3.42 - 41.4) <b>P &lt; 0.001</b>	1	15	<b>P &lt; 0.001</b> (N = 43)
	DP (N = 30, 135)	7.64 (2.17 - 40.8) <b>P &lt; 0.001</b>	1	9	<b>P = 0.0114</b> (N = 30)
	Combined ACT (N=73, 278)	8.90 (3.88 - 23.69) <b>P &lt; 0.001</b>	2	24	<b>P &lt; 0.001</b> (N = 73)
<i>pfmdr1</i> codons 86, 184, 1246 NFD	AL (N = 26, 101)	3.15 (1.19 - 8.60) <b>P = 0.001</b>	1	9	<b>P = 0.0114</b> (N = 22)
	DP (N = 15, 104)	8.52 (1.76 - 80.3) <b>P = 0.002</b>	1	6	P = 0.0588 (N = 15)
	Combined ACT (N=42, 206)	3.59 (1.68 - 7.95) <b>P &lt; 0.001</b>	2	15	<b>P = 0.0016</b> (N = 38)

\* change in genotype in the same patient between day 0 and day 3 is scored as loss or gain; significance tested using McNemar's test of asymmetry

**Codons 86, 184 and 1246 of *pfmdr1***

Previous studies have proposed that the haplotype NFD at codons 86, 184 and 1246 is associated with parasite recurrence after AL. We collated information at these three positions into haplotypes, using strict criteria to eliminate ambiguity due to mixed infections by excluding all isolates with mixed alleles called at two or more of the codons of interest [14]. The proportion of children carrying the haplotype NFD prior to treatment was 38.4%, but this rose to 69.1% on day 3 (N = 42; OR 3.59; 95% CI 1.68 - 7.95; P < 0.001). However, this strict haplotype definition may have led to biased loss of data from pre-treatment isolates because of higher parasite density, and thus greater clonal multiplicity. The analysis was repeated using less stringent criteria for assigning *pfmdr1* haplotypes (i.e. assigning the NFD haplotype to all ambiguous isolates where this may have been present). This also showed significantly higher prevalence of the NFD haplotype (*sensu lato*) on day 3 than in the baseline population (N = 48 at day 3; OR 4.31, 95% CI 2.09 - 9.30; P < 0.001). Paired analysis on both days 0 and 3 at all three codon positions was available for 38 children, and evidence of significant within-host directional selection was found for the NFD haplotype *sensu strictu* (P = 0.0016). Despite loss of statistical power, stratification by treatment group suggested that this effect occurred in both the AL (N=22) and DP arms (N=15) (P = 0.011, 0.059 respectively; Table 1). Presence of the NFD haplotype at day 0 was not associated with risk of recrudescence in either arm (data not shown).

**Polymorphisms in *pfap2-mu***

As this is the first study to examine the role of *pfap2-mu* polymorphisms in a prospective study of ACT sensitivity, sequence data was obtained at all 621 codons for 166 pre-treatment isolates, and for codons 121-399 for a further 78 isolates. A variety of mutations including synonymous and non-synonymous single nucleotide polymorphisms, deletions and insertions were identified within this gene in the study population, and these are summarised in Tables 2 and 3. We were able to assemble 57 distinct haplotypes from the 166 full-length *pfap2-mu* sequences, 38 of which only occurred once. The most common haplotype, found in 32 pre-treatment isolates, was identical to the reference sequence from 3D7.

Pilot analysis of the first 20 isolates found to have persisting parasites on day 2 or day 3 identified the non-synonymous polymorphism at codon 160, Ser to either Asn or Thr (Table 2), as differing in prevalence between pre- and post-treatment infections. We therefore focussed on this mutation for detailed analysis. Among 244 evaluable pre-treatment

samples, 18.3% and 1.2% carried the Asn or Thr alleles, respectively, at codon 160 of *pfap2-mu*. In contrast, combining 32 evaluable paired samples, each consisting of one sample collected before treatment (day 0) and one sample collected after the treatment (day 2 or day) from the same patient, the prevalence of parasites with either the S160N or S160T variant rose immediately following ACT treatment from 28.1% to 40.6% (OR 2.87, 95% CI 1.20 – 6.61;  $P = 0.006$ ). Among these 32 individuals, evidence of directional selection for either variant was found between day 0, with nine of the individuals carrying either mutant or mixed alleles (mutant and Wt) and day 2/3 ( $P = 0.046$ ), with an extra four individuals carrying the mutant variants (S160N/T). This selection was not seen at the day of failure, when the overall prevalence of codon 160 mutations was 25% (Table 2). There was no evidence that carriage of the S160N or S160T variant prior to treatment was associated with risk of recurrent infection (data not shown).

**Table 2.** Synonymous and non-synonymous single nucleotide polymorphisms in the *pfap2-mu* gene, and prevalence at day 0, day 2/3 and day of failure after ACT treatment.

Codon	Reference sequence	AA	Nucleotide substitution	AA changes	Prevalence day 0 (N=244)*	Prevalence day 2/3 (N=32)	Prevalence day failure (N=28)
5	G	Leu	15A	-	8.4%	4.2%	no data
146	G	Arg	437A	Lys	1.2%	0%	3.6%
160	G	Ser	479A	Asn	18.0%	37.5%	25.0%
			479C	Thr	1.2%	3.1%	0%
161	G	Val	483A	-	0.4%	0%	0%
162	T	Ile	486C	-	9.8%	3.1%	0%
163	A	Glu	489G	-	16.8%	18.8%	17.9%
188	A	Arg	564G	-	0.8%	3.1%	0%
199	A	Lys	596C	Thr	3.3%	3.1%	7.1%
200	A	Asn	598T	Tyr	0.4%	0%	0%
233	T	Asn	699G	Lys	0.4%	0%	0%
337	C	Ala	1010G	Gly	1.2%	0%	no data
324	T	Cys	1026C	-	0.6%	0%	no data
437	C	Phe	1311A	Leu	4.2%	9.4%	no data
476	T	Ser	1428G	-	4.2%	3.1%	no data
478	A	Val	1434T	-	2.4%	0%	no data

The middle sequencing fragment (codons 121-399) was successfully analysed in all isolates. Codon 5 was not determined in 2 isolates without fragment 1 data; codons 5, 337, 324, 437, 476 and 478 were not determined in 74 isolates without fragment 1 or 3 data, and codons 337, 324, 437, 476 and 478 were not determined in 1 isolate without fragment 3 data.

**Table 3.** Indels identified in the *pfap2-mu* gene, consequent amino acid replacements and prevalence at day 0, day 2/3 and day fail after treatment.

Codon	Reference sequence	Deletions/ Insertions	Prevalence day 0 (N=244)	Prevalence day 2/3 (N=32)	Prevalence day failure (N=28)
226	7xAsn	5xAsn / 6xAsn	0.4% / 0.4%	0% / 0%	0% / 0%
		8xAsn / 9xAsn	17.6% / 1.2%	9.4% / 3.1%	25.0% / 0%
233	1xLys	2xLys	2.0%	3.1%	7.1%
319	5xAsn	6xAsn	12.7%	6.3%	42.9%
326	4xAsn	5xAsn	13.1%	9.4%	3.6%

### ***Polymorphisms in pfubp1***

An amplification strategy was designed for a region of *pfubp1* from codons 1463 to 1563, encompassing the polymorphic codon 1528 identified by Borrmann *et al.* [19] as being associated with *in vitro* parasite responses to artemisinin in Kenya. Direct sequencing of this region was successful in 123 pre-treatment isolates, and identified 16 distinct haplotypes defined by synonymous and non-synonymous point mutations, indels of one to 15 amino acids and repeat number variations in low complexity nucleotide tracts (Figure 1). We focussed on the codon E1528D substitution, which occurred in 12 of 123 evaluable individuals (9.8%) prior to treatment. Day 3 finger-prick samples had been largely exhausted by investigations of the other three loci, and by previous qPCR analysis [9], but sequencing of *pfubp1* was possible for 35 samples from day 3, of which 6 (17.1%) encoded Asp at codon 1528. To increase the sample, we amplified this region from 33 parasitological failures identified by microscopy on day 28 or day 42 [20], of which 14 (42.4%) carried 1528D. Thus evidence was found that the E1528D mutation was significantly more common among parasite isolates after treatment (days 3, 28 or 42) than among the pre-treatment population (OR 3.85, 95% CI 1.63 - 9.32;  $P < 0.001$ ). Paired analysis in the 36 evaluable individuals (i.e. those with *pfubp1* sequence data on day 0 and at least one of day 3, day 28 or day 42) showed strong evidence of directional selection ( $P = 0.002$ ). Carriage of the 1528D variant at day 0 was not associated with risk of recurrent infections (data not shown).

↓

```

1. n=51 RKQNIQDWSSYTKDKENKLNMDDDINMNKGNQDVNRTYKNEKNKEE-DKYGKNEKNE-----KYDKYDKYEKYEKYDKYKKDNKNQHDDPLYDNINKNYDNDNKGL
2. n=25 RKQNIQDWSSYTKDKENKLNMDDDINMNKGNQDVNRTYKNEKNKEE-DKYGKNEKNE-----KYDKYDKY[K]KYEKYEKYDKYKKDNKNQHDDPLYDNINKNYDNDNKGL
3. n=11 RKQNIQDWSSYTKDKENKLNMDDDINMNKGNQDVNRTYKNEKNKEE-DKYGKNEKNE-----KYDKYDKYDKYEKYEKYDKYKKDNKNQHDDPLYDNINKNYDNDNKGL
4. n=11 RKQNIQDWSSYTKDKENKLNMDDDINMNKGNQDVNRTYKNEKNKEE-DKYGKNEKNE-----KYDKYDKY[D]KYEKYEKYDKYKKDNKNQHDDPLYDNINKNYDNDNKGL
5. n= 7 RKQNIQDWSSYTKDKENKLNMDDDINMNKGNQDVNRTYKNEKNKEE-DKYGKNEKNE-----KYDKY[K]KYEKYEKYDKYKKDNKNQHDDPLYDNINKNYDNDNKGL
6. n= 6 RKQNIQDWSSYTKDKENKLNMDDDINMNKGNQDVNRTYKNEKNKEE-DKYGKNEKNE-----KYDKYDKYDKYDKYDKYEKYEKYDKYKKDNKNQHDDPLYDNINKNYDNDNKGL
7. n= 2 RKQNIQDWSSYTKDKENKLNMDDDINMNKGNQDVNRTYKNEKNKEE-DKYGKNEKNE-----KYDKYDKYEKYEKYDKYKKDNKNQHDDPLYDNINKNYDNDNKGL*
8. n= 2 RKQNIQDWSSYTKDKENKLNMDDDINMNKGNQDVNRTYKNEKNKEE-DKYGKNEKNE[K]EKYDKYDKYDKYDKYDKYDKYDKYEKYEKYDKYKKDNKNQHDDPLYDNINKNYDNDNKGL*
9. n= 1 RKQNIQDWSSYTKDKENKLNMDDDINMNKGNQDVNRTYKNEKNKEE-DKYGKNEKNE-----KYDKYDKY[K]KYDKY[K]KYEKYEKYDKYKKDNKNQHDDPLYDNINKNYDNDNKGL
10. n= 1 RKQNIQDWSSYTKDKENKLNMDDDINMNKGNQDVNRTYKNEKNKEE-DKYGKNEKNE-----KYDKYDKYEKY[K]KY[K]KYEKYEKYDKYKKDNKNQHDDPLYDNINKNYDNDNKGL
11. n= 1 RKQNIQDWSSYTKDKENKLNMDDDINMNKGNQDVNRTYKNEKNKEE-DKYGKNEKNE-----KYDKY[K]KY[D]KYEKYEKYDKYKKDNKNQHDDPLYDNINKNYDNDNKGL
12. n= 1 RKQNIQDWSSYTKDKENKLNMDDDINMNKGNQDVNRTYKNEKNKEE-DKYGKNEKNE---KYDKYDKYDKYDKYDKYDKYDKYEKYEKYDKYKKDNKNQHDDPLYDNINKNYDNDNKGL
13. n= 1 RKQNIQDWSSYTKDKENKLNMDDDINMNKGNQDVNRTYKNEKNKEEEDKYGKNEKNE-----KYDKYDKYEKYEKYDKYKKDNKNQHDDPLYDNINKNYDNDNKGL
14. n= 1 RKQNIQDWSSYTKDKENKLNMDDDINMNKGNQDVNRTYKNEKNKEEEDKYGKNEKNE-----KYDKY[K]KYDKYEKYEKYDKYKKDNKNQHDDPLYDNINKNYDNDNKGL
15. n= 1 RKQNIQDWSSYTKDKENKLNMDDDINMNKGNQDVNRTYKNEKNKEEEDKYGKNEKNE-----KYDKYEKYEKY[K]KYDKYEKYEKYDKYKKDNKNQHDDPLYDNINKNYDNDNKGL
16. n= 1 RKQNIQDWSSYTKDKENK[N]MDDDINMNKGNQDVNRTYKNEKNKEE-DKYGKNEKNE-----KYDKYDKYEKYEKYDKYKKDNKNQHDDPLYDNINKNYDNDNKGL

```

**Figure 1. Haplotype frequencies at codons 1463 – 1563 of *pfubp1* in 123 pre-treatment isolates.** A 303nt fragment was amplified from genomic DNA using primers described in the text, and sequenced directly. Sequences were ordered from the most frequent to the least, and aligned in Clustal W and formatted in Boxshade, with additional hand-editing for clarity. Codon 1258, as identified by Borrmann *et al.* [19] is arrowed. Haplotype 1 is identical to the sequence found in the 3D7 reference genome. \*Haplotypes 7 and 8 carry a synonymous mutation at codon 1518, encoding Asn. [The experimental work contributing to this figure was done by Gisela Henriques and Rachel Johnson].



***Polymorphism of pfap2-mu and pfubp1 in the global genome sequence database***

Having identified two novel candidate loci contributing to the genetic signature of persisting sub-microscopic *P. falciparum* in our treated Kenyan children, we sought to examine diversity in these two loci across 631 genomes using PlasmoView software [23]. For *pfap2-mu*, the S160N/T polymorphism occurred across both West African (Burkina Faso, Gambia, Ghana, Mali, Senegal) and East African (Kenya, Malawi) parasite populations. This polymorphism did not occur in SE Asian populations (Thailand, Cambodia, and Vietnam) nor in PNG (Fig. 2, left). For *pfubp1*, diversity across the locus was less geographically distinct, and mutations around codons 1520 – 1540 occurred in all populations (Fig. 2, right). By contrast, the recently described polymorphisms at codons 493, 539, 543 and 580 of the kelch gene (PF3D7\_1343700), associated with artemisinin sensitivity in Cambodia [6], were restricted to SE Asia, and do not occur in available African *P. falciparum* genomes. In contrast, the kelch polymorphism K189T was very common among African isolates but absent from Asian parasites included in the publicly available sample (data not shown).

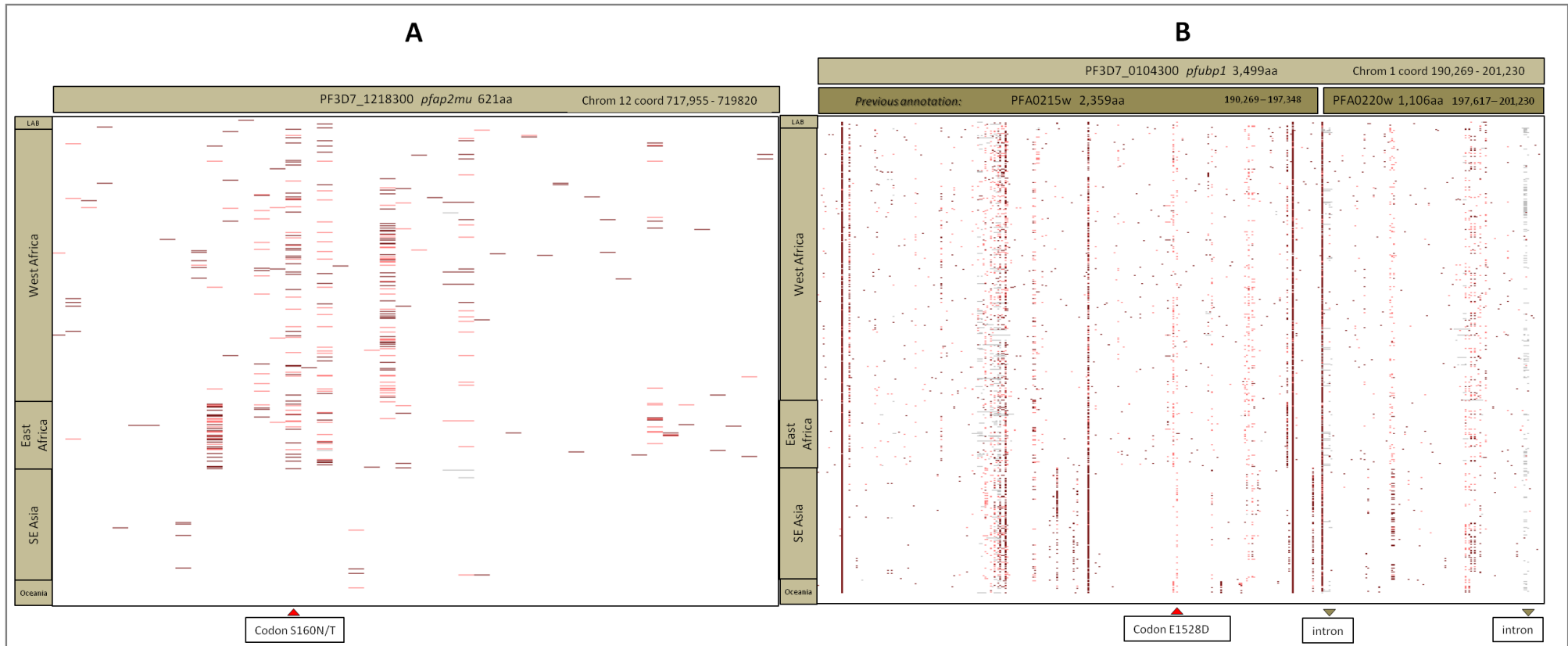

**Figure 2. Global sequence diversity in *pfap2-mu* (A) and *pfubp1* (B) across genome sequences from 631 *P. falciparum* isolates mapped to the 3D7 reference genome [23].** Coloured bars at any chromosome position (horizontal axis) denote a non-reference substitution at that residue in the relevant isolate (vertical axis). At left is the regional origin of isolates in the analysis, comprising 8 laboratory isolates (Lab), 367 isolates from West Africa, 88 from East Africa, 151 from SE Asia and 17 from Oceania. Codon S160N/T of *pfap2-mu* and codon 1528 of *pfubp1* are highlighted by red arrows at the bottom of the figure. For *pfubp1*, the position of two carboxy-terminal introns is also marked. Previous annotation of this region of chromosome 1 as two distinct genes (PFA0215w and PFA0220w) is shown above the right-hand figure. [The experimental work contributing to this figure was done by Colin Sutherland].

## DISCUSSION

We have genetically characterised sub-microscopic *P. falciparum* infections in ACT-treated children from Mbita, Kenya and described a novel genetic signature at the *pfprt*, *pfmdr1*, *pfap2-mu* and *pfubp1* candidate drug-resistance marker loci. For three of these loci, the signature was already present three days after treatment with either AL or DP. For *pfubp1*, selection was seen on day of recrudescence in the case of later treatment failures. By microscopy, all children were parasite-free at day 3 and afebrile, and thus these were persisting, sub-microscopic and asymptomatic infections which, in some cases, contributed to mosquito transmission potential on day 7 and patent recrudescent parasitaemia on day 28 or day 42 [9, 20]. The evidence that these variant genotypes were over-represented on day 3, immediately following completion of the full (observed) course of either AL or DP, suggests that selection is exerted partly or primarily by the artemisinin component of combination therapy, and that *P. falciparum* response to artemisinin *in vivo* is modulated by variation at these loci. Although not directly shown by our data, this interpretation is supported by a recent study in Uganda [24], which found that lumefantrine and piperaquine did not select for the same haplotypes of *pfmdr1* in recurrent infections, implying that early selection for the NFD haplotype is exerted by the artemisinin component in both treatment arms.

Previous studies have documented selection at the *pfprt* and *pfmdr1* loci in late recurrent infections in ACT-treated African children [13-16], but this is the first demonstration of selection on day 3. The favoured CQ-sensitive haplotypes *pfprt* CVMNK and *pfmdr1* NFD were supplanted in the late 20<sup>th</sup> century by the spread of CQ-resistance. Thus it is difficult to distinguish between a general disadvantage *in vivo* caused by the relative lack of fitness of CQ-resistant *P. falciparum* in the absence of CQ [25, 26], and a specific interaction between these loci and artemisinin. Our study was not powered, nor designed, to explore inter-locus interactions, but we observed both *pfmdr1*-NFD and *pfprt*-CVMNK in 43 of 204 evaluable patients on day 0, and in 21 of 34 evaluable sub-microscopic infections on day 3 (OR 6.05, 95% CI 2.62 – 14.2;  $P < 0.001$ ). This may suggest the benefit of the two wild-type genes was enhanced by the presence of artemisinin. Another weakness of our study was that some isolates of interest were not sequenced at all loci, mainly due to exhaustion of small, finite blood samples. Although the limited number of observations in each of the treatment arms precluded comparisons of effect estimates due to lack of

power, an exploratory stratification was carried out, generating odds ratios with very wide confidence intervals (data not shown).

The S160N or S160T variants showed directional selection with a higher prevalence in samples collected 2 or 3 days after the drug treatment. However, comparisons between the prevalence of the different alleles before and after the treatment were only possible in a relatively small number of samples. The directional selection for *pfap2-mu* 160 (AL:  $p=0.015$ ; DP:  $p=0.063$ ) and *pfubp1* (AL:  $p=0.0002$ ; DP:  $p=0.029$ ) remained evident in both arms. Future studies with adequate power can now be designed using these estimates of prevalence and effect size, to more accurately determine the role of these genes in modulations of artemisinin *in vivo* responses. Moreover, age and multiplicity of infection were associated with parasite persistence in the Mbita trial [9], and thus are also potential confounders. These parameters should be investigated by multi-variate regression in studies with sufficient power to further dissect the interplay among parasite genotypes, host factors and different treatment regimens.

This study provides the first preliminary evidence that *P. falciparum* response to artemisinin *in vivo* may be modulated by polymorphisms in the loci *pfap2-mu* and *pfubp1*, both homologues of genes identified in studies of experimentally-induced artemisinin resistance in the rodent parasite *P. chabaudi* [17, 18]. Clathrin-mediated endocytosis is a mechanism common to eukaryotic cells by which membrane-associated proteins and other cargo are transported from the plasma membrane, *trans*-Golgi network or endosomes to acceptor compartments; the adaptor complex 2 is associated with cell surface endocytosis, recruiting to the vesicle both cargo and structural components including clathrin, and may have a role in haemoglobin trafficking in malaria parasites. The ubiquitination of proteins modulates endocytosis and proteosomal recycling, with known substrates including P-glycoproteins such as Pgh1 (encoded in malaria parasites by *pfmdr1*) [27]. Thus these two loci may both contribute to endosomal digestion of haemoglobin in malaria parasites [18].

The persistence of microscopically undetectable parasites following treatment of clinical malaria does not constitute *in vivo* antimalarial resistance as normally defined, and may have been equally common in the pre-ACT era. The application of a novel endpoint, qPCR positivity within 72 hours of treatment, has merely permitted this to be observed for the first time. In settings where a significant proportion of malaria patients are semi-immune,

newly acquired super-infecting parasites may flourish and cause symptomatic malaria, despite the presence of pre-existing “symbiotic” genotypes hitherto stably suppressed by the immune response, but adapted to continuing survival. As we have previously hypothesised [28], it may be these pre-existing parasites that remain in some individuals after drug clearance of the symptomatic infection. This hypothesis is only plausible if current ACT regimens are ineffective against low density parasitaemia, but recent data do suggest this is the case [28, 29]. Evaluation of current and alternative regimens against asymptomatic parasitaemia, using appropriate study protocols specifically designed for this purpose, is required to test this possibility.

Our interpretation is that the phenomenon studied here is not antimalarial resistance *per se*. Consistent with this, the genetic signature described does not resemble that of the “artemisinin-resistant” parasites associated with the slow-clearance phenotype in Cambodia. Firstly, the latter do not carry the CVMNK haplotype of *pfcr1* and, secondly, *pfmdr1* polymorphisms are not associated with the phenotype [30]. Finally, we found no evidence of codon 160 polymorphism in *pfap2-mu* occurring in SE Asian isolates in the available genomic sequence database, nor evidence of kelch propeller domain polymorphism in any African isolates [6]. We thus conclude that the persisting sub-microscopic parasites observed in our cohort of ACT-treated Kenyan children are not related to slow-clearing parasites as seen in Cambodia and nearby countries. Only polymorphisms in *pfubp1* may be shared determinants in Cambodia and Kenya. PF3D7\_0104300 encompasses two loci, PFA0215w and PFA0220w, from earlier genome annotations (Fig. 2B), and variant alleles of the former were identified in sub-populations of *P. falciparum* in Cambodia associated with slow clearance after artesunate monotherapy [31].

We have described a novel genetic signature at four loci in *P. falciparum*, and implicate these genes in modulating *in vivo* parasite response to artemisinin. Further evaluation in purpose-designed, adequately powered studies of asymptomatic malaria *in vivo*, and in genetically modified *P. falciparum in vitro*, are needed to determine the potential public health implications of these observations, and the utility of these loci as markers of artemisinin sensitivity in natural populations of *P. falciparum* worldwide.

### Funding

This work was supported by the EU FP7 MALACTRES Consortium; the Fundação para a Ciência e a Tecnologia (FCT) of Portugal (grant number SFRH/BD/63129/2009) to GH; the EDCTP WANECAM Project to KBB and CJS; the UK Medical Research Council to TGC; and Public Health England to CJS. None of the authors report a conflict of interest arising from the publication of this work.

### Acknowledgements

We thank Dr Henk Schallig for encouragement and support as Coordinator of MALACTRES, and Prof. David C. Warhurst for helpful discussions. We thank KEMRI for assistance in protocol development, and for review of our study documentation. This paper has been approved for publication by the Director, KEMRI.

### References

- 1 Aregawi MW, Ali AS, Al-mafazy AW et al. Reductions in malaria and anaemia case and death burden at hospitals following scale-up of malaria control in Zanzibar, 1999-2008. *Malar J* **2011**; 10: 46.
- 2 Karema C, Aregawi MW, Rukundo A et al. Trends in malaria cases, hospital admissions and deaths following scale-up of anti-malarial interventions, 2000-2010, Rwanda. *Malar J* **2012**; 11: 236.
- 3 Noedl H, Se Y, Schaecher K, Smith BL, Socheat D, Fukuda MM; Artemisinin Resistance in Cambodia 1 (ARC1) Study Consortium. Evidence of artemisinin-resistant malaria in western Cambodia. *N Engl J Med* **2008**; 359: 2619-2620.
- 4 Dondorp AM, Nosten F, Yi P et al. Artemisinin resistance in *Plasmodium falciparum* malaria. *N Engl J Med*. **2009**; 361: 455-67.
- 5 Cheeseman IH, Miller BA, Nair S et al. A major genome region underlying artemisinin resistance in malaria. *Science* **2012**; 336: 79-82.
- 6 Arieu F, Witkowski B, Amaratunga C et al. A molecular marker of artemisinin-resistant *Plasmodium falciparum* malaria. *Nature* **2014**; 505: 50-5.
- 7 Krishna S, Kremsner PG. Antidogmatic approaches to artemisinin resistance: reappraisal as treatment failure with artemisinin combination therapy. *Trends Parasitol* **2013**; 29: 313-7.
- 8 Borrmann S, Sasi P, Mwai L et al. Declining responsiveness of *Plasmodium falciparum* infections to artemisinin-based combination treatments on the Kenyan coast. *PLoS One* **2011**; 6: e26005.
- 9 Beshir KB, Sutherland CJ, Sawa P et al. Residual *Plasmodium falciparum* parasitemia in Kenyan children after artemisinin-combination therapy is associated with increased transmission to mosquitoes and parasite recurrence. *J Infect Dis* **2013**; 208: 2017-24

- 10 Sutherland CJ, Allouche A, Curtis J et al. Gambian children successfully treated with chloroquine can harbour and transmit *Plasmodium falciparum* gametocytes carrying resistance genes. *Am J Trop Med Hyg* **2002**; 67: 578-85.
- 11 Hallett RL, Dunyo S, Ord R et al. Treatment of malaria in Gambian children with chloroquine plus sulphadoxine-pyrimethamine favours survival and transmission to mosquitoes of multi-drug-resistant *Plasmodium falciparum*. *PLoS Clin Trials* **2006**; 1: e15.
- 12 Méndez F, Herrera S, Murrain B et al. Selection of antifolate-resistant *Plasmodium falciparum* by sulfadoxine-pyrimethamine treatment and infectivity to *Anopheles* mosquitoes. *Am J Trop Med Hyg* **2007**; 77: 438-43.
- 13 Sisowath C, Stromberg J, Martensson A et al. In vivo selection of *Plasmodium falciparum* *pfmdr1* 86N coding alleles by artemether-lumefantrine (Coartem). *J Infect Dis* **2005**; 191: 1014-7.
- 14 Humphreys GA, Merinopoulos I, Ahmed J et al. Amodiaquine and artemether-lumefantrine select distinct alleles of the *Plasmodium falciparum* *pfmdr1* gene in Tanzanian children treated for uncomplicated malaria. *Antimicrob. Agents Chemother.* **2007**; 51: 991-7.
- 15 Sisowath C, Petersen I, Veiga MI et al. In vivo selection of *Plasmodium falciparum* parasites carrying the chloroquine-susceptible *pfcr* K76 allele after treatment with artemether-lumefantrine in Africa. *J Infect Dis.* **2009**; 199: 750-7.
- 16 Gadalla NB, Adam I, Elzaki SE et al. Increased *pfmdr1* copy number and sequence polymorphisms in *Plasmodium falciparum* isolates from Sudanese malaria patients treated with artemether-lumefantrine. *Antimicrob. Agents Chemother.* **2011**; 55: 5408-11.
- 17 Hunt P, Afonso A, Creasey A et al. Gene encoding a deubiquinating enzyme is mutated in artesunate- and chloroquine-resistant rodent malaria parasites. *Mol. Microbiol.* **2007**; 65: 27-40.
- 18 Henriques G, Martinelli A, Rodrigues L et al. Artemisinin resistance in rodent malaria-mutation in the AP2 adaptor  $\mu$ -chain suggests involvement of endocytosis and membrane protein trafficking. *Malar J.* **2013**; 12: 118.
- 19 Borrmann S, Straimer J, Mwai L et al. Genome-wide screen identifies new candidate genes associated with artemisinin susceptibility in *Plasmodium falciparum* in Kenya. *Sci Rep.* **2013**; 3: 3318.
- 20 Sawa P, Shekalaghe SA, Drakeley CJ et al. Malaria transmission after artemether-lumefantrine and dihydroartemisinin-piperazine: a randomized trial. *J Infect Dis.* **2013**; 207: 1637-45.
- 21 Gadalla NB, Elzaki SE, Mukhtar E, Warhurst DC, El-Sayed B, Sutherland CJ. Dynamics of *pfcr* alleles CVMNK and CVIET in chloroquine-treated Sudanese patients infected with *Plasmodium falciparum*. *Malaria J* **2010**; 9: 74.
- 22 van Schalkwyk DA, Burrow R, Henriques G et al. Culture-adapted *Plasmodium falciparum* isolates from UK travellers: in vitro drug sensitivity, clonality and drug resistance markers. *Malaria J.* **2013**; 12: 320.
- 23 Preston MD, Assefa SA, Ocholla H et al. PlasmoView: A web-based resource to visualise global *Plasmodium falciparum* genomic variation. *J Infect Dis.* **2014**; 209: 1808-15.
- 24 Conrad MD, Leclair N, Arinaitwe E et al. Comparative impacts over 5 years of artemisinin-based combination therapies on *Plasmodium falciparum* polymorphisms that modulate drug sensitivity in Ugandan children. *J Infect Dis.* **2014**; (in press).
- 25 Laufer MK, Thesing PC, Eddington ND et al. Return of chloroquine antimalarial efficacy in Malawi. *N Engl J Med* **2006**; 355: 1959-66.
- 26 Ord R, Alexander N, Dunyo S et al. Seasonal carriage of *pfcr* and *pfmdr1* alleles in Gambian *Plasmodium falciparum* implies reduced fitness of chloroquine-resistant parasites. *J Infect Dis* **2007**; 196: 1613-9.
- 27 Zhang Z, Wu J-Y, Hait W, Yang J.-M. Regulation of the stability of P-glycoprotein by ubiquitination. *Mol Pharmacol* **2004**; 66: 395-403.

- 28 Dinko B, Oguike MC, Larbi JA, Bousema T, Sutherland CJ. Persistent detection of *Plasmodium falciparum*, *P. malariae*, *P. ovale curtisi* and *P. ovale wallikeri* after ACT treatment of asymptomatic Ghanaian school-children. *Int.J. Parasitol: Drugs and Drug Resistance* **2013**; 3: 45–50.
- 29 Chijioke-Nwauche I, van Wyk A, Nwauche C, Beshir KB, Kaur H, Sutherland CJ. HIV-positive Nigerian adults harbor significantly higher serum lumefantrine levels than HIV-negative individuals seven days after treatment for *Plasmodium falciparum* infection. *Antimicrob Agents Chemother.* **2013**; 57: 4146-50.
- 30 Imwong M, Dondorp AM, Nosten F et al. Exploring the contribution of candidate genes to artemisinin resistance in *Plasmodium falciparum*. *Antimicrob Agents Chemother.* **2010**; 54: 2886-92.
- 31 Miotto O, Almagro-Garcia J, Manske M et al. Multiple populations of artemisinin-resistant *Plasmodium falciparum* in Cambodia. *Nat Genet.* **2013**; 45: 648-55.



# Chapter 6

---

***IN VITRO* ANTIMALARIAL SUSCEPTIBILITY OF *PLASMODIUM*  
*FALCIPARUM* ISOLATES FROM BURKINA FASO AND MOLECULAR  
MARKERS OF DRUG RESISTANCE**

**This chapter will be submitted to Malaria Journal after further revisions:**  
Henriques G., Beshir, K., Tinto H., D'Alessandro U., Hallett R., Sutherland C.J. *In vitro*  
antimalarial susceptibility of *Plasmodium falciparum* isolates from Burkina Faso and  
association with polymorphisms in candidate markers



Registry

T: +44(0)20 7299 4646  
F: +44(0)20 7299 4656  
E: registry@lshtm.ac.uk

**COVER SHEET FOR EACH 'RESEARCH PAPER' INCLUDED IN A RESEARCH THESIS**

Please be aware that one cover sheet must be completed for each 'Research Paper' included in a thesis.

1. For a 'research paper' already published

1.1. Where was the work published? .....

1.2. When was the work published? .....

1.2.1. If the work was published prior to registration for your research degree, give a brief rationale for its inclusion  
.....  
.....  
.....

1.3. Was the work subject to academic peer review? .....

1.4. Have you retained the copyright for the work? Yes / No

If yes, please attach evidence of retention.

If no, or if the work is being included in its published format, please attach evidence of permission from copyright holder (publisher or other author) to include work

2. For a 'research paper' prepared for publication but not yet published

2.1. Where is the work intended to be published? *Habazia Journal* .....

2.2. Please list the paper's authors in the intended authorship order

*Henriques G, Beshir K, Tinto H, D'Alessandro U, Hallett R, Sutherland C.*

2.3. Stage of publication – Not yet submitted / Submitted / Undergoing revision from peer reviewers' comments / In press

3. For multi-authored work, give full details of your role in the research included in the paper and in the preparation of the paper. (Attach a further sheet if necessary)

*I genotyped the samples, analysed data and drafted the article.*

NAME IN FULL (Block Capitals) *GISELA CRISTINA LOURENÇO HENRIQUES*

STUDENT ID NO: *298382*

CANDIDATE'S SIGNATURE *Gisela Henriques* Date *27/08/2014*

SUPERVISOR/SENIOR AUTHOR'S SIGNATURE (3 above)

*Calvin* *27/08/2014*

## Abstract

In 2006, Burkina Faso adopted artemisinin-based combination therapy (ACT) as the first-line treatment for uncomplicated malaria. To determine whether parasite susceptibility has been affected by the introduction of the ACTs in Burkina Faso, an *ex vivo* susceptibility study was conducted on *P. falciparum* isolates obtained during a clinical trial of Artemether-Lumefantrine (AL) and Artesunate-Amodiaquine (AS + AQ). Here we investigate the association between *in vitro* antimalarial drug susceptibility with genetic polymorphisms in *pfubp1*, *pfap2-mu* and *pf26S-protSU*, three new molecular marker candidates that have been implicated in artemisinin resistance in *Plasmodium chabaudi*. Data revealed that polymorphisms in *pfubp1* and *pf26S-protSU* can modulate *in vitro* and *in vivo* responses to Lumefantrine. Additionally, this study is in agreement with the recent suggestion that polymorphisms in *pfap2-mu* may contribute to *P. falciparum* susceptibility to multiple drugs. Further studies are necessary to further confirm the importance of these new molecular markers in modulating *P. falciparum* antimalarial drug susceptibility.

## Introduction

Resistance to antimalarial drugs represents a major obstacle for control and elimination of malaria in endemic countries. In response to increasing resistance to antimalarials and to delay the development of resistance, artemisinin based combination therapies (ACTs) are now the mainstay of recommended treatment for *P. falciparum* malaria. ACT, which combines highly potent artemisinin (ART) derivatives with long acting partner compounds are the most effective antimalarial drugs available at the moment (WHO, 2013).

Burkina Faso is located in the middle of the West African Sahel region and is one of the poorest countries in the world, ranking 183 out of 186 countries as surveyed by the United Nations Development Program's 2012 Human Development Index (Programme, 2014). Malaria is a major public health problem in Burkina Faso, with the entire population at risk for Infection. Despite suggestion of a general decline in malaria burden in sub-Saharan Africa, health facilities reported an increase in the number of malaria cases in Burkina Faso from an estimated 2 million in 2007 to 6 million in 2012 (WHO, 2013). In 2005, Burkina Faso adopted ACT as first-line treatment against malaria and chloroquine was replaced by artemether-lumefantrine (AL) and artesunate amodiaquine (AQ +AS). However, since the introduction of ACT there are very little data available on the efficacy of ACT against *Plasmodium falciparum* in Burkina Faso. Due to the essential role of ACTs in malaria control, monitoring of the efficacy of both ART and its partner drug is a crucial step in preventing any potential catastrophic failure of ACTs.

To determine whether parasite susceptibility has been affected by the introduction of the ACTs in Burkina Faso, an *ex vivo* susceptibility study was conducted on *P. falciparum* isolates obtained during a clinical trial of AL and AS + AQ (Tinto *et al.* 2014). The *P. falciparum* isolates were assessed for their susceptibility to several antimalarial drugs. In the present study, we investigate the relationship between the *in vitro* susceptibilities to the different drugs and the prevalence of polymorphisms in recently identified genes associated with antimalarial resistance. The loci of interest included genes encoding a de-ubiquitinating enzyme (*ubp-1*) (Hunt *et al.* 2007; Hunt *et al.* 2010), the mu ( $\mu$ ) chain of the AP2 adaptor protein complex (*ap2-mu*) [(Henriques *et al.* 2013); Chapter 4], and the 26S proteasome regulatory subunit (*26S-protSU*) (Rodrigues, Cravo *et al.*, in preparation). The potential associations between the polymorphisms found and treatment outcome were also investigated by comparing parasite genotypes of pre- and post-treatment isolates.

These new candidates have been implicated in artemisinin resistance in the rodent malaria parasite *Plasmodium chabaudi*. A recent study conducted in Kenya also showed that mutations in the *pfap2-mu* and *pfubp1* genes may modulate the responses to artemisinin combination treatments *in vivo* (Henriques *et al.* 2014) (Chapter 5).

## Material and Methods

### Study site and clinical isolates

*Plasmodium falciparum* DNA was available from one clinical trial conducted at the Dafra Health Centre in Bobo-Dioulasso, Burkina Faso (Dr Halidou Tinto, unpublished results; ClinicalTrials.gov identifier: NCT00808951). In brief, the study was conducted to determine the *in vivo* and *in vitro* efficacy of AL and AS + AQ, in children with uncomplicated malaria. Children aged 6 months to 15 years, with *P. falciparum* mono-infection (parasitaemia of 4,000-200,000 asexual parasites per  $\mu$ l), fever (axillary temperature  $\geq 37.5$  °C or fever in the last 24 hours) and whose parents or guardians agreed on participation were eligible to participate. Overall 440 participants were enrolled and randomized to receive AL or AS + AQ during three periods (December 2008 to February 2009, from July 2009 to March 2010 and from July to December 2010). Treatment efficacy was assessed during a period of 42 day follow-up and the isolates were tested by the laboratory team of Dr. Halidou Tinto, Centre Muraz, Bobo Dioulasso, using the classical *in vitro* isotopic microtest technique. For each patient isolate  $IC_{50}$  estimates were generated for dihydroartemisinin (DHA), quinine (QN), chloroquine diphosphate (CQ), lumefantrine (LUM), piperaquine (PIP) and monodesethylamodiaquine (MDA) (Tinto *et al.*, 2014). At the end of the follow-up, the patients were classified according to their clinical and parasitological responses into treatment failure or adequate clinical and parasitological response (ACPR). Nested PCR reaction was used to genotype the MSP-1, MSP-2 and GLURP markers to distinguish true treatment failures from new infections (Halidou Tinto, unpublished results). The study was reviewed and approved by the Institutional Ethics Committee of Centre Muraz. The clinical and *ex vivo* susceptibility data, and dried filter-paper blood samples from each patient, were kindly provided for this study by the team of Dr Halidou and the MALACTRES consortium, coordinated by Dr Henk Schallig, Royal Tropical Institute, Amsterdam.

### In vivo treatment outcomes

Of the 950 patients screened, 643 (67.7%) were positive for *P. falciparum* of which 440 were qualified for enrolment (Figure 1).

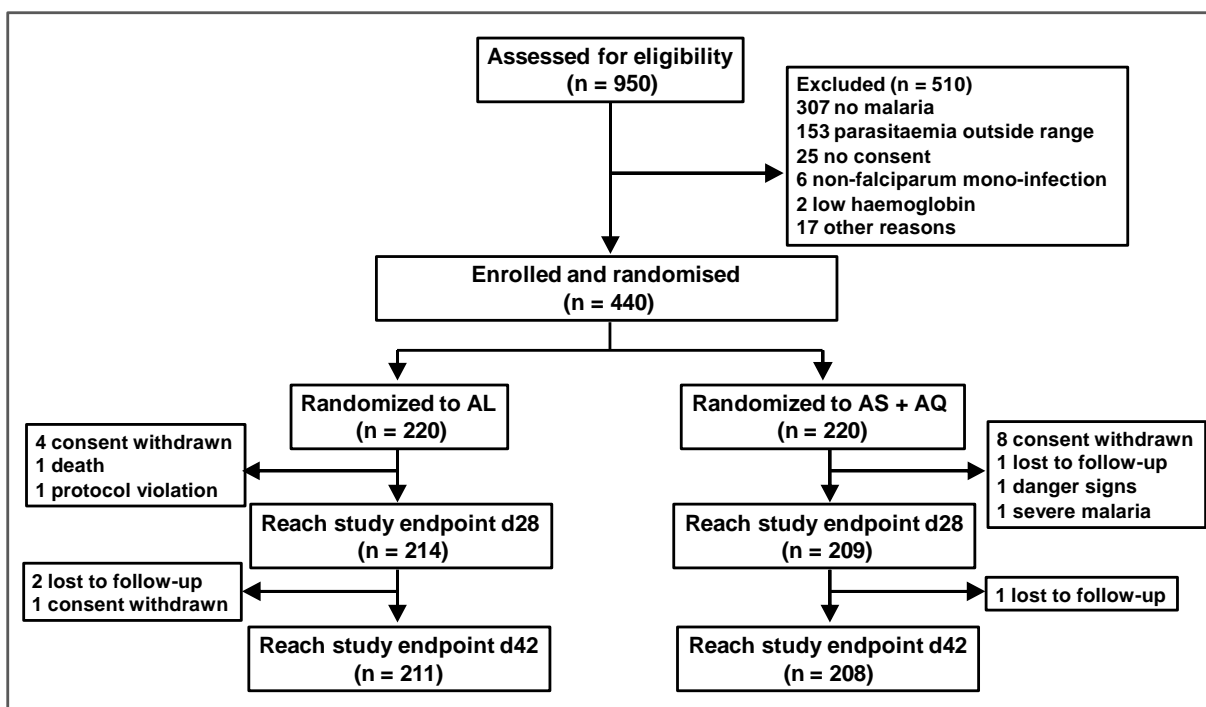

**Figure 1:** Trial profile.

Of the 419 cases that completed the follow-up, 104 (49.3%) in the AL arm and 148 (71.2%) in the AS + AQ treatment arm were defined as adequate clinical and parasitological response (ACPR). In the AL treatment arm 107 (50.7%) of the 211 children had recurrent parasitaemia during follow-up. MSP-1, MSP-2 and GLURP diversity analysis of day 0 samples versus samples from the day of recurrence identified 19 (9.0%) recrudescence infections and 88 (41.7%) re-infections outcomes. In the AS + AQ treatment arm 60 (28.8%) of the 208 children had recurrent infections. They were classified as recrudescences 4 (1.9%) and re-infections 56 (26.9%) after PCR correction (Table 1).

**Table 1.** Treatment outcomes for AL or AS + AQ against *P. falciparum* malaria in Burkina Faso

Outcome	Treatment received	
	AL N = 211	AS+AQ N = 208
Outcome	Number (%)	
Adequate clinical and parasitological response (ACPR)	104 (49.3%)	148 (71.2%)
Recurrent infections	107 (50.7 %)	60 (28.8%)
Due to re-infection*	88 (41.7%)	56 (26.9%)
Due to recrudescence	19 (9.0%)	4 (1.9%)

\* PCR corrected values up to day 42

### Analysis of parasite genetic polymorphisms in candidate genes

For this study, polymorphisms of the candidate genes were determined using a PCR and sequencing method. Parasite genomic DNA was isolated from filter paper samples by extraction with Chelex method, as previously described (Plowe *et al.* 1995).

The *pfap2-mu* gene and a 300 bp fragment of the *pfubp-1* gene (containing the codon 1528) were amplified using primers previously described (van Schalkwyk *et al.* 2013; Henriques *et al.* 2014). The complete *pf26S-prot5U* gene was amplified using the primers and the PCR conditions described below. Each PCR was performed in a total volume of 25  $\mu$ L with the following reaction mixture: 0.2  $\mu$ M of each primer, 4.0 mM MgCl<sub>2</sub>, 0.4  $\mu$ M deoxynucleotides (dNTPs), 1 U Bioline Taq polymerase (Bioline, UK) and 5  $\mu$ L of target DNA template. The thermal cycle program was 94°C for 3 min, and 40 cycles of 94°C for 30 sec, annealing temperature for 30 sec and 68°C for 45 sec with a final extension of 68°C for 15 min. The primer sequence and annealing temperatures for the amplifications are described in Table 2.

**Table2.** Primer sequences, PCR product sizes and annealing temperatures for 1<sup>st</sup> and 2<sup>nd</sup> amplification used for the PCR amplifications of *pf26S-protSU* genes.

Gene	Fragment	1 <sup>st</sup> amplification primers (5' to 3')	PCR product size	Annealing temperature
<i>pf26S-protSU</i>	1	Fw - CCGCCAGTGGTGAATAGC Rev - GTCTAGCATCTAAAGCAACACC	597bp	55°C
	2	Fw - GTTGATGAAATGATAGATGTGTGC Rev - GCCATCATTATTGCCTTATCATC	690 bp	52°C
	3	Fw - GATAATCTAACAAATGATGAACC Rev - CGTATTTTCATCATTACTATCTCC	744 bp	52°C
	4	Fw - GCAAATTATAACACCAATGACAAG Rev - CCTGCGCTTACTATAGCACC	875 bp	55°C
	5	Fw - CGAATGAACACTGTAATCCAAAC Rev - ACAGGGATTTTCATATCGACC	842 bp	55°C
	6	Fw - GCCAAAAGTAAAAGTGAGCC Rev - GTGGTGCCTCTTTTTAGACG	494 bp	55°C

Amplified DNA was purified using Exonuclease I and Thermosensitive Alkaline Phosphatase enzymes (Fermentas, UK) and sequenced using BigDye® Terminator v3.1 Cycle Sequencing Kit (Applied Biosystems, UK) (van Schalkwyk *et al.* 2013). Sequences were aligned with the Geneious Pro software (version 5.5.3; Biomatters, New Zealand) with manual editing.

### Statistical analysis

Data were analyzed using GraphPad Prism 6.0 (GraftPad Software, San Diego, California). Infections with mixed mutant/wild-type genotypes at the *pfubp-1*, *pfap2-mu* and *pf26S-protSU* loci were analyzed as mutant. The chi-squared distribution was used to evaluate the difference in genotype frequencies between pre-treatment samples and post-treatment samples (day fail). The Mann–Whitney test (with significance level set at 0.05) was applied to investigate whether or not there are significant differences between *in vitro* IC<sub>50</sub> estimates for each antimalarial drug and each observed polymorphism in the genes of interest. . As the study was the first of its kind with these loci, and thus exploratory in nature, we did not deploy any correction for multiple tests, but retained the 5% cut-off for statistical significance.



## Results

*P. falciparum* isolates were tested for their *ex vivo* susceptibility to QN, CQ, MDA, LUM, DHA at day 0 (before treatment) and day fail after treatment. The mean IC<sub>50</sub> for each anti-malarial drug is presented in Table 3. No significant difference was found between mean day 0 and day fail IC<sub>50</sub> estimates (data not shown).

**Table 3.** *In vitro* susceptibility of *P. falciparum* isolates from Burkina Faso to quinine (QN), chloroquine (CQ), monodesethylamodiaquine (MDA), lumefantrine (LUM), dihydroartemisinin (DHA) and piperazine (PIP) at day 0 and at day fail.

Drug	Day 0			Day fail		
	N	IC <sub>50</sub> Mean (nM)	Range (nM)	N	IC <sub>50</sub> Mean (nM)	Range (nM)
QN	382	221.4	10.2 – 950.3	89	223.3	11.9 - 1421.4
CQ	382	152.6	8.3 – 921.8	88	150.5	9.9 - 548.7
MDA	377	25.0	0.8 – 595.9	87	21.8	5.4 - 62.2
LUM	382	40.5	0.8 – 166.1	87	44.6	1.0 - 171.1
PIP	349	10.8	0.8 - 375.2	81	9.9	1.0 - 194.8
DHA	381	1.3	0.2 – 38.8	88	1.1	0.1 - 16.4

### Polymorphisms in *pfubp1*

A partial sequence of the *pfubp1* gene was sequenced (from codons 1463-1563) in 92 isolates from day 0 and in 125 isolates from day fail after the treatment, as previously described (Henriques *et al.*, 2014; Chapter 5). Overall, seven polymorphic sites were observed, consisting of three single nucleotide polymorphisms (SNPs) and four indels. Two of these SNPs were non-synonymous mutations, causing amino acid changes at Asp1525Glu and Glu1528Asp while only one was a synonymous mutation (at codon 1518). One indel lead to a deletion of a Glutamic acid (E) at position 1507 and the remaining three indels lead to both insertions and deletions of three amino acids at positions 1513, 1519 and 1525 (KNE, KYD and KYE, respectively). Details of the genetic polymorphisms identified, consequent encoded amino acids and corresponding prevalences are shown in Table 4. We were able to assemble 33 distinct haplotypes.

**Table 4.** SNPs and indels identified in the *pfubp1* gene, consequent amino acid replacements and prevalence at day 0, in reinfections and recrudescence isolates

Codon	Reference sequence (3D7)	Amino acid	Nucleotide substitution	Amino acid changes	Prevalence at Day 0 (N=92)	Prevalence in reinfections (N=113)	Prevalence in recrudescences (N=12)
1518	C	Asn	4554T	none	0 %	2.7 %	0 %
1525	C	Asp	4575A	Glu	3.3 %	2.7 %	16.7 %
1528	A	Glu	4584C	Asp	6.5 %	9.7 %	0 %
<b>Deletions / Insertions</b>							
	Reference sequence (3D7)	Amino acid deletion / insertion					
1507	2xE	1xE		2.2 %	3.5 %	0 %	
1513	2xKNE	1xKNE / 3xKNE		4.3 % / 1.1 %	0.9 % / 0.9 %	0 %	
1519	2xKYD	1xKYD / 3xKYD		4.3 % / 5.4 %	4.4 % / 1.8 %	8.3 % / 0 %	
1525	2xKYE	1xKYE / 3xKYE		15.2 % / 12.0 %	21.2% / 18.6 %	0 % / 0 %	

### Polymorphisms in *pfap2-mu*

Full length coding sequence of *pfap2-mu* was determined in 52 pre- and post-treatment isolates, and a partial sequence (codons 122-399) was obtained for a further 461 pre- and post-treatment isolates. DNA sequencing from the 513 isolates revealed nucleotide substitutions at 6 different positions, with 4 of these causing amino acid shifts at positions Gly99Ala, Arg146Lys, Ser160Asn and Asn233Lys. Table 5 shows detailed information on the genetic polymorphisms identified, corresponding encoded amino acids and prevalence. A second source of genetic diversity detected in the *pfap2-mu* gene was sequence length variation due to the presence of indels. The majority of the indels observed lead to insertions of the AAT codon that corresponds to an insertion of an Asn residue in the polypeptide chain at positions 226, 319 and 326 (Table 5). The remaining indel corresponds to an insertion of a Lysine residue at position 233. A total of 21 different haplotypes were identified.

The amino acid substitution at position 99 (leading to a Glycine to Alanine substitution) is a previously undescribed mutation; all the other nine polymorphisms were described in previous studies (Henriques et al. 2013; Henriques et al, 2014).

**Table 5.** SNPs and indels identified in the *pfap2-mu* gene, consequent amino acid replacements and prevalence at day 0, in reinfections and recrudescence isolates

Codon	Reference sequence (3D7)	Amino acid	Nucleotide substitution	Amino acid changes	Prevalence at Day 0 (N=381)	Prevalence in reinfections (N=115)	Prevalence in recrudescences (N=17)
99*	G	Gly	296C	Ala	5.1 %	0 %	-
146	G	Arg	437A	Lys	2.6 %	0 %	0 %
160	G	Ser	479A	Asn	11.3 %	4.3 %	11.8 %
163	A	Glu	489G	none	0 %	7.0 %	5.9 %
188	A	Arg	564G	none	0 %	7.8 %	17.6 %
233	T	Asn	699G	Lys	2.9 %	3.5 %	0 %

**Deletions / Insertions**

	Reference sequence (3D7)	Amino acid deletion / insertion			
226	7xAsn	8xAsn	20.9%	22.6%	41.2 %
233	1xLys	2 xLys	2.1%	3.5%	0 %
319	5xAsn	6xAsn	9.4%	15.6%	11.8 %
326	4xAsn	5xAsn	16.3%	13.0%	5.9 %

\*Codon 99 was only determined in 39 Day 0 and 13 Day fail isolates.

### Polymorphisms in *pf26S-protSU*

Analysis of the full *pf26S-protSU* open reading frame (ORF) within 96 isolates from day 0 revealed eight polymorphic sites consisting of four non-synonymous mutations resulting in amino acid changes at positions Tyr107Phe, Asn250Lys, Glu535Ala and Lys711Arg, three synonymous mutations (at codons 123, 140 and 947) and one indel (Table 6). The 535 SNP was the most prevalent polymorphism found (96.9%), being present in 93 of the 96 samples analyzed. The detected indel lead to an insertion of one or more Asn residues (numbers of Asn repeats ranged between 7 and 19). The 9xAsn and 10xAsn were the most frequent numbers of Asn repeats observed, at a frequency of 41.7 % and 26.1 %, respectively. We detected 36 distinct haplotypes.

**Table 6.** SNPs and indels identified in the *pf26S-protSU* gene, consequent amino acid replacements and prevalence at day 0

Codon	Reference sequence (3D7)	Amino acid	Nucleotide substitution	Amino acid changes	Prevalence at Day 0 (N=96)
107	A	Tyr	320T	Phe	4.2 %
123	A	Arg	369G	none	5.2 %
140	G	Gly	420A	none	2.1 %
250	T	Asn	750A	Lys	12.5 %
535	A	Glu	1601C	Ala	96.9 %
711	A	Lys	2132G	Arg	13.5 %
947	G	Thr	2841A	none	3.1 %
	<b>Reference sequence (3D7)</b>		<b>Amino acid deletion / insertion</b>		4.2 %
			7xAsn / 8xAsn		5.2 % / 8.3 %
			9xAsn / 10xAsn		41.7 % / 26.1 %
429	6xAsn		11xAsn / 12xAsn		5.2 % / 5.4 %
			13xAsn / 14xAsn		1.0 % / 5.2 %
			15xAsn / 17xAsn / 19xAsn		1.0 % / 1.0 % / 1.0 %

### Correlation between polymorphisms and the *in vivo* outcomes

To determine if any of the studied *pfubp1* and *pfap2-mu* polymorphisms was under selection, the prevalence of the different alleles was compared between baseline infections and reinfections and recrudescences. The prevalence of the 1525Glu *pfubp1* mutation is higher in recrudescence (16.7%) than in pre-treatment (3.3%) or reinfections (2.7%) isolates (Table 4). However, this difference is not statistically significant ( $p=0.10$  and  $p=0.12$ , respectively). There was no evidence that carriage of the 1525Glu mutation prior to treatment was associated with risk of recurrent infection (data not shown).

From the eight non synonymous mutations and indels described in *pfap2-mu*, an insertion of an Asn residue at position 226, was the only polymorphism statistically significantly selected in recrudescence infections (20.9 % versus 41.2%;  $p=0.0011$ ).

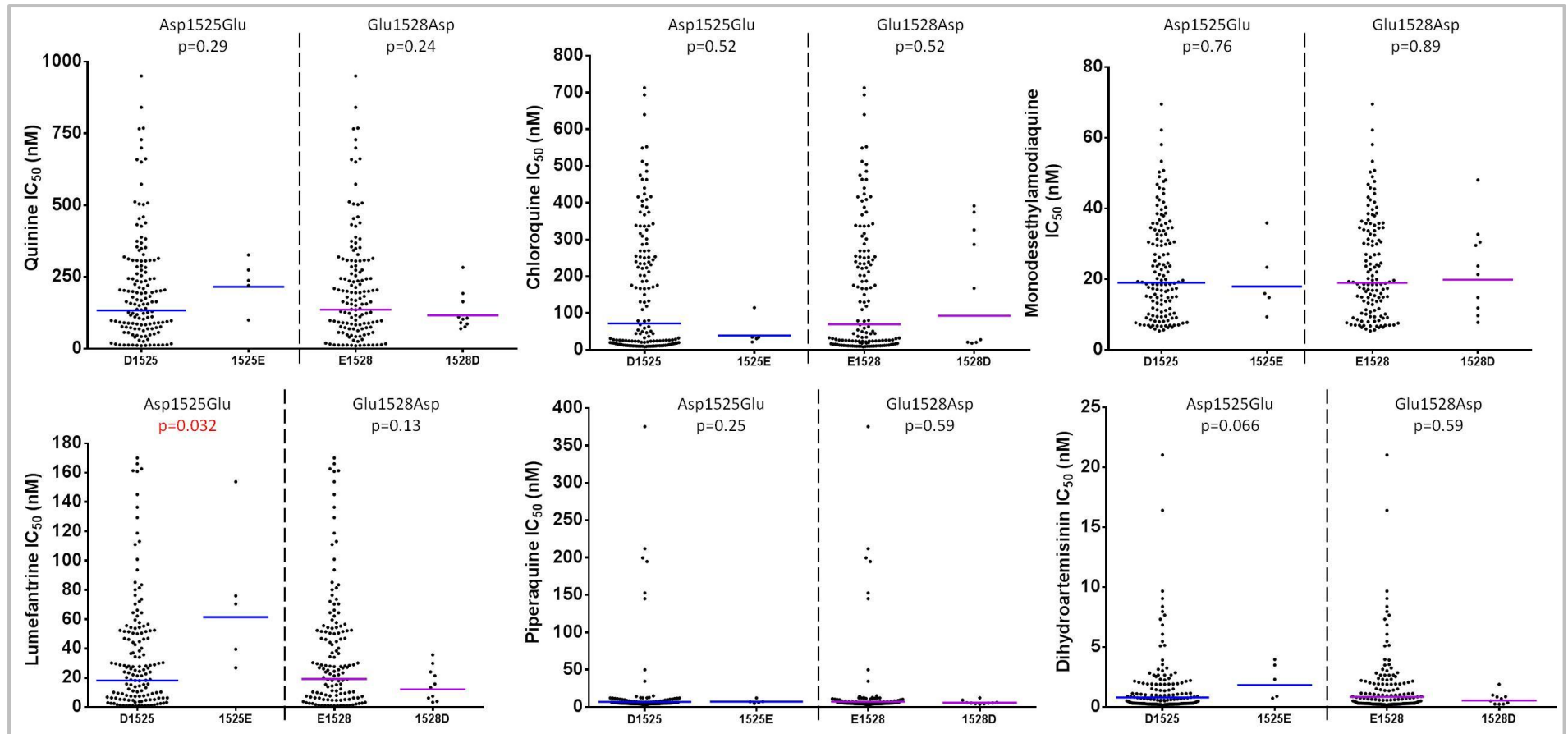

**Figure 2: Association of non-synonymous SNPs in *pfubp1* with responses to QN, CQ, MDA, LUM, PIP and DHA.** For each drug,  $IC_{50}$  values for each individual isolate are shown as black dots; geometric means are shown as colored bars. Statistical significance between groups was determined by Mann – Whitney tests ( $p < 0.05$  are in red).

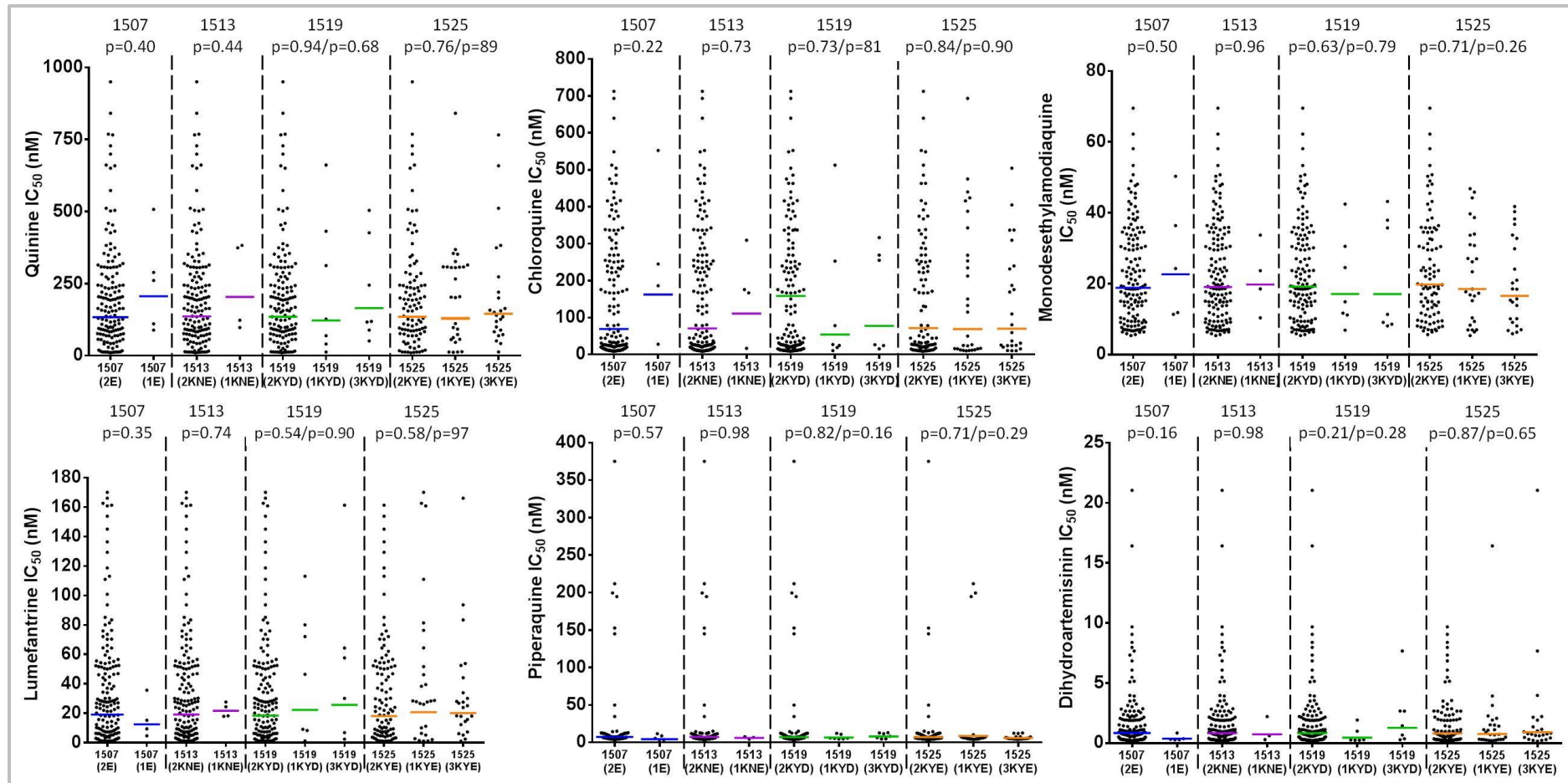

Figure 3: Association of Indels in *pfubp1* with responses to QN, CQ, MDA, LUM, PIP and DHA. (See legend to Figure 2)

### Correlation between polymorphisms and *in vitro* drug responses

Association between the IC<sub>50</sub> to QN, CQ, MDA, LUM, PIP and DHA and *P. falciparum* polymorphisms in *pfubp1* and *pfap2-mu* was assessed in pre-treatment and recurrent infections. This association was also assessed for *pf26S-protSU* gene but only in pre-treatment samples. Only indels and non-synonymous polymorphisms were included in the analysis. The Gly99Ala *pfap2-mu* locus was excluded from the analysis due to the small sample size.

Analysis of the potential associations between *pfubp1* polymorphisms and drug responses revealed a significant but borderline increase in susceptibility to LUM in isolates carrying the 1525Glu mutation (73 nM; 95 % CI: 12-135) compared with those carrying the WT allele (36 nM; 95 % CI: 30-42) ( $p=0.032$ ; Mann-Whitney test) (Figure 2). Parasites carrying this mutation also had diminished sensitivity to QN (231.7 nM; 95 % CI: 127.2-336.3) and DHA (2.3 nM; 95 % CI: 0.5-4.1) compared to isolates carrying the wild type allele [(QN 211.1 nM; 95 % CI:180.2-242.0); (DHA 1.7 nM 95 % CI:1.2-2.1)]. However, this difference is not statistically significant ( $p=0.29$  and  $p=0.07$ , respectively; Mann-Whitney test) (Figure 2).

No significant association was observed between *pfubp1* insertions or deletions and IC<sub>50</sub> estimates for any antimalarial drug (Figure 3).

Evaluation of *pfap2-mu* polymorphisms revealed that isolates carrying the mutant 146Lys allele appeared to be significantly more sensitive to QN (109.9 nM; 95 % CI:51.2-168.6), CQ (47.6 nM; 95 % CI:6.7-88.5) and MDA (13.8 nM; 95 % CI:10.8-16.9) than those carrying the wild type allele [(QN 227.1 nM; 95 % CI:209-245.3); CQ; 159.0 nM; 95 % CI:142.2-175.9); (MDA 23.4 nM; 95 % CI:21.9-24.90)] ( $p = 0.009, 0.020$  and  $0.029$ , respectively; Mann-Whitney test) (Figure 4). The trend was similar in samples carrying the 233Lys allele. The mean QN IC<sub>50</sub> in isolates carrying the 233Lys mutation was 126 nM (95 % CI: 75.0-177.1), significantly lower than in isolates carrying the wild type allele (mean = 227.5; 95 % CI: 209.3-245.7) ( $p=0.023$ ; Mann-Whitney test) (Figure 4).

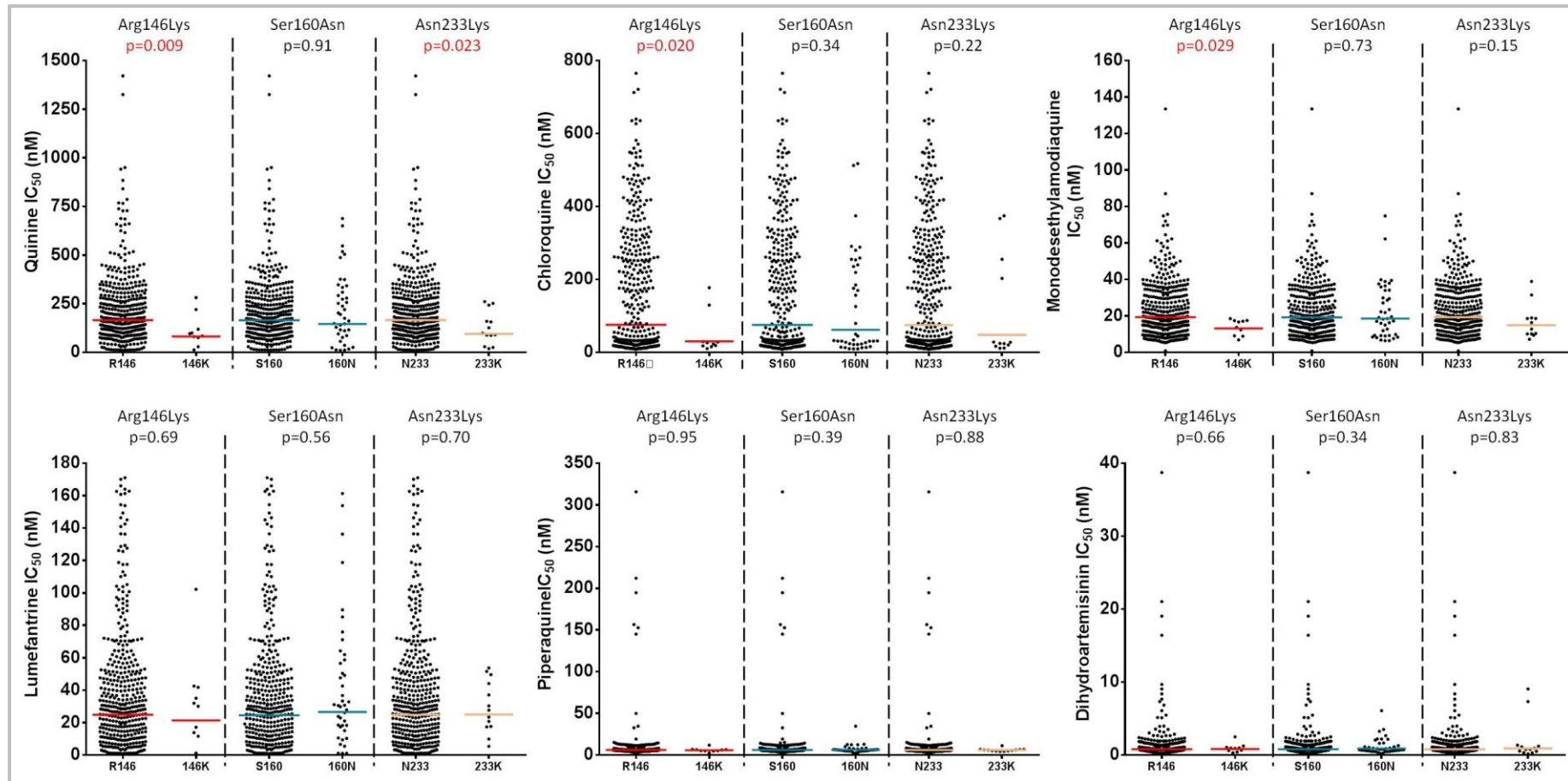

Figure 4: Association of non-synonymous SNPs in *pfap2-mu* with responses to QN, CQ, MDA, LUM, PIP and DHA. (See legend to Figure 2)



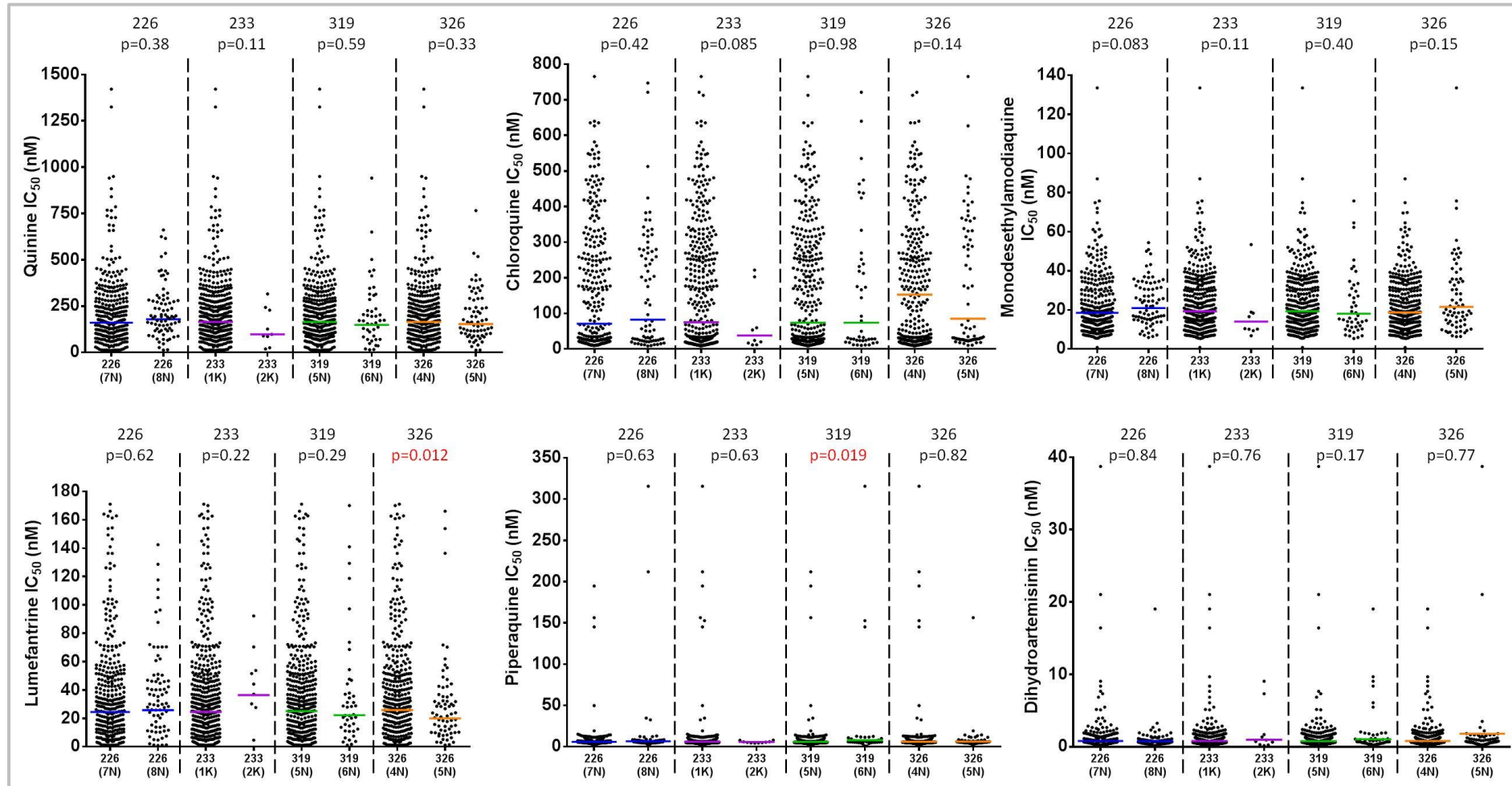

Figure 5: Association of Indels in *pfap2-mu* with responses to QN, CQ, MDA, LUM, PIP and DHA. (See legend to Figure 2)

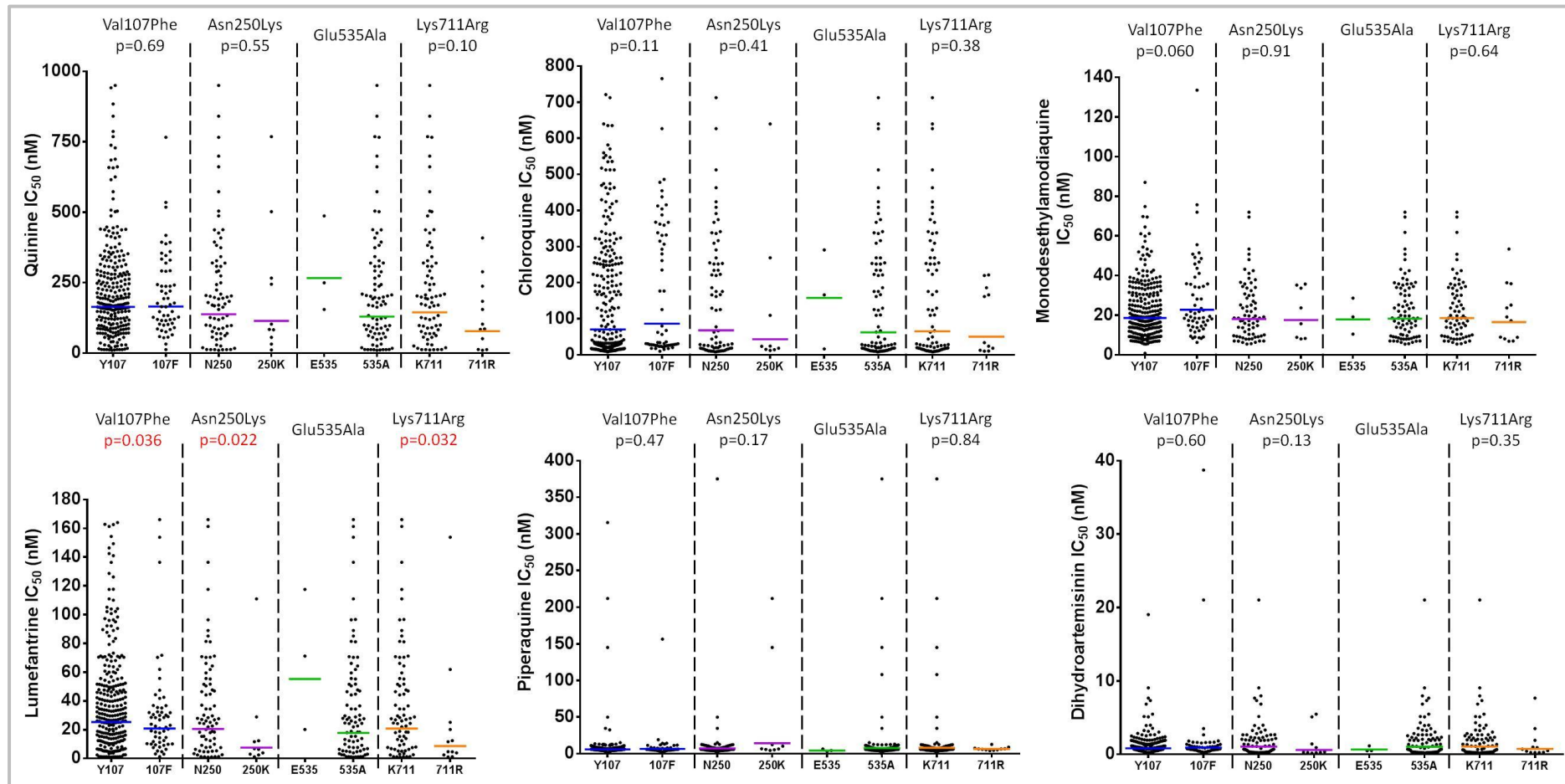
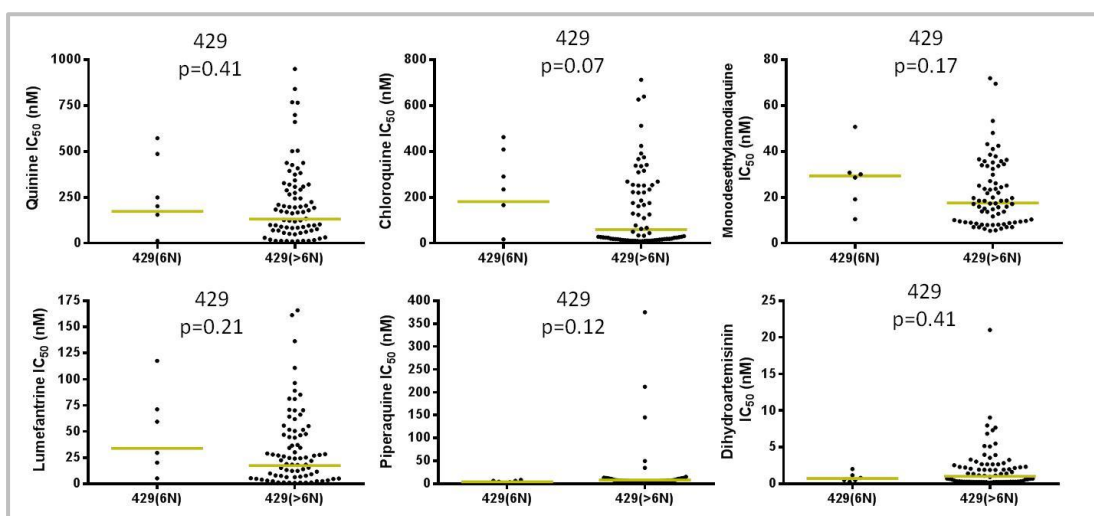

Figure 6: Association of non-synonymous SNPs in *pf26S-protSU* with responses to QN, CQ, MDA, LUM, PIP and DHA. (See legend to Figure 2).

We found a weak association between insertion of an Asn residue at position 319 of *pfap2-mu* and reduced susceptibility to PIP. Isolates carrying six Asn residues had a mean  $IC_{50}$  of 8 nM (95 % CI: 6.1-9.9) compared to 22.8 nM (95 % CI: 3.1-42.6) in those isolates carrying only five Asn repeats ( $p=0.09$ ; Mann-Whitney test) (Figure 5). In contrast, parasites carrying an extra Asn amino acid at position 326 have increased susceptibility to LUM (30 nM 95 % CI: 23-38) when compared with wild type isolates (42 nM; 95 % CI:23-38) ( $p=0.012$ ; Mann-Whitney test) (Figure 5).

None of the mutations in *pf26S-protSU* were associated with reduced sensitivity to any of the drugs analyzed (Figure 6 and Figure 7). However we found significant association of the wild type allele at amino acid positions 107 (41 nM; 95 % CI:36-45), 250 (37 nM; 95 % CI:29-46) and 711 (39 nM; 95 % CI:30-47) with reduced sensitivity to lumefantrine ( $p=0.036$ , 0.022 and 0.032, respectively; Mann-Whitney test) (Figure 6). For isolates carrying the 107Phe, 250Lys and 711Arg alleles the LUM  $IC_{50}$  mean was 31 nM (95 % CI:22-40), 19 nM (95 % CI:0-43) and 25 nM (95 % CI:0-53), respectively.



**Figure 7: Association of insertions in codon 429 in *pf26S-protSU* with responses to QN, CQ, MDA, LUM, PIP and DHA. (See legend to Figure 2).**

## Discussion

Chemotherapy with ACTs has proved very effective and is one of the factors contributing to recent reductions in the malaria burden (WHO, 2012). Therefore, monitoring of drug efficacy and identification of potential molecular markers as well as understanding the mechanisms modulating parasite susceptibility to both artemisinin and its partner drug is a critical step towards sustaining the efficacy of ACTs.

In this study we evaluated associations between polymorphisms in *pfubp1*, *pfap2-mu* and *pf26S-protSU* genes with *in vitro* susceptibilities of *P. falciparum* isolates from Burkina Faso to QN, CQ, MDA, LUM, PIP and DHA. We also investigated potential associations between the polymorphisms found and treatment outcomes.

Molecular analysis of antimalarial drug resistance markers showed a high degree of polymorphisms in the three loci investigated. Analysis of *pfubp1*, *pfap2-mu* and *pf26S-protSU* sequences revealed seven, ten and eight polymorphic regions, respectively, and thus a large number of distinct haplotypes circulating. This is compatible with our observations for *pfubl1* and *pfap2mu* in Kenya (Henriques *et al* 2014; Chapter 5). The diversity in these genes, none of which are either membrane transporters or known drug targets, is surprising.

In the parasite population under study the 1525Glu *pfubp1* mutation was significantly associated with increased LUM *in vitro* susceptibility. Interestingly, this mutation also appears to be more prevalent in recrudescence isolates than in pre-treatment isolates. Of note, the majority of the recrudescences occurred in the AL treatment arm (83%) (Table 1). Taken together these results suggest that the 1525Glu *pfubp1* polymorphism has a role in modulating parasite susceptibility to LUM *in vitro* and *in vivo* sensitivity responses.

Regarding *pfap2-mu* polymorphisms, the insertion of an Asn at position 319 was significantly associated with reduced susceptibility to PIP. Furthermore, isolates carrying an extra Asn residue at position 226 were significantly more likely to recrudescence. In contrast, parasites carrying the Arg146 wild type allele were more susceptible to QN, CQ and MDA. Similarly, parasites with the Asn233 wild type allele were also more susceptible to QN. These data is in agreement with the recent suggestion that polymorphisms in *pfap2-mu* may modulate *P. falciparum* responses to multiple drugs (Henriques *et al.*, unpublished; Chapter 7).

Although previous reports have shown association of *pfap2-mu* 160Asn/Tyr and *pfubp1* 1528Asp mutations and the ACT responses [Chapter 4; (Henriques *et al.* 2014; Chapter 5)], in this study we did not find any significant association between these polymorphisms and treatment outcome or *in vitro* drug susceptibilities. The most likely explanation for this finding is that the direct correlation between point mutations and drug susceptibility may be dependent of the geographic origin of the parasites (implying different genetic backgrounds). As East and West Africa parasites may differ in terms of antimalarial drug pressures and parasite genetics (Dippmann *et al.* 2008) it is possible that the association of *pfap2-mu* and *pfubp1* mutations and modulation of drug responses observed in other studies may be dependent on the genetic background of the parasites. Furthermore, selection of the 160Asn/Tyr *pfap2-mu* was noted on day 2 or 3 after the ACT treatment but was not present in recurrent infections. This finding stresses the importance of studying the parasite population dynamics during the first few days of ACT treatment, which was not done in the Burkina Faso study.

The present study provides the first data on *pf26S-protSU* alleles. Reduced sensitivity to LUM was significantly associated with wild type alleles in three loci (107, 250 and 711), suggesting that mutations in *pf26S-protSU* can modulate *in vitro* responses to this drug. However, further studies are needed to confirm this relationship.

In conclusion, the data obtained in the present study might be used as a baseline for surveillance of resistance markers to ACT in future studies. Nevertheless, more in-depth studies are necessary to determine the implications of genetic polymorphisms in these three candidate drug resistance loci, on *in vivo* and *in vitro* antimalarial drug susceptibility. Furthermore, the genetic background of the parasites appears to be critical in determining drug susceptibility, so further investigation is required to validate candidate polymorphism in *pfubp1*, *pfap2-mu* and *pf26S-protSU* genes as molecular markers of drug susceptibility in different geographical settings.

## References

- Dippmann, A. K., U. Bienzle, et al. (2008). "*pfmdr1* mutations in imported African *Plasmodium falciparum* isolates." *Trans R Soc Trop Med Hyg* 102(11): 1148-1150.
- Henriques, G., R. L. Hallett, et al. (2014). "Directional selection at the *pfmdr1*, *pfcr1*, *pfubp1* and *pfap2mu* loci of *Plasmodium falciparum* in Kenyan children treated with ACT." submitted to *J Infect Dis* : revised version requested.
- Henriques, G., A. Martinelli, et al. (2013). "Artemisinin resistance in rodent malaria--mutation in the AP2 adaptor mu-chain suggests involvement of endocytosis and membrane protein trafficking." *Malar J* 12: 118.
- Hunt, P., A. Afonso, et al. (2007). "Gene encoding a deubiquitinating enzyme is mutated in artesunate- and chloroquine-resistant rodent malaria parasites." *Molecular Microbiology* 65(1): 27-40.
- Hunt, P., A. Martinelli, et al. (2010). "Experimental evolution, genetic analysis and genome re-sequencing reveal the mutation conferring artemisinin resistance in an isogenic lineage of malaria parasites." *BMC Genomics* 11: 499.
- Plowe, C. V., A. Djimde, et al. (1995). "Pyrimethamine and proguanil resistance-conferring mutations in *Plasmodium falciparum* dihydrofolate reductase: polymerase chain reaction methods for surveillance in Africa." *Am J Trop Med Hyg* 52(6): 565-568.
- Programme, U. N. D. (2014). "National and Regional Human Development Reports." Retrieved July, 2014, from <http://hdr.undp.org/en/data>.
- Tinto, H., L. N. Bonkian, et al. (2014). "*Ex vivo* anti-malarial drugs sensitivity profile of *Plasmodium falciparum* field isolates from Burkina Faso five years after the national policy change." *Malar J* 13: 207.
- van Schalkwyk, D. A., R. Burrow, et al. (2013). "Culture-adapted *Plasmodium falciparum* isolates from UK travellers: in vitro drug sensitivity, clonality and drug resistance markers." *Malar J* 12: 320.
- WHO (2012). *World malaria Report: 2012*, World Health Organization.
- WHO (2013). *World Malaria Report*, World Health Organization.

# Chapter 7

---

## THE MU-SUBUNIT OF *PLASMODIUM FALCIPARUM* CLATHRIN-ASSOCIATED ADAPTOR PROTEIN 2 MODULATES *IN* *VITRO* PARASITE DRUG RESPONSE TO ARTEMISININ & QUININE

**This chapter is based on the following manuscript:** Henriques G., van Schalkwyk D.A, Burrow R., Warhurst D.C., Thompson E., Baker D.A., Hallett R., Fidock D.A., Flueck C., Sutherland C.J.. 2015. The mu-subunit of *Plasmodium falciparum* clathrin-associated adaptor protein 2 modulates *in vitro* parasite drug response to artemisinin and quinine. *Antimicrob. Agents and Chemother.* First published online 17 February, 2015, doi: 10.1128/AAC.04067-1



Registry

T: +44(0)20 7299 4646  
F: +44(0)20 7299 4656  
E: registry@lshtm.ac.uk

**COVER SHEET FOR EACH 'RESEARCH PAPER' INCLUDED IN A RESEARCH THESIS**

Please be aware that one cover sheet must be completed for each 'Research Paper' included in a thesis.

**1. For a 'research paper' already published**

- 1.1. Where was the work published? .....
- 1.2. When was the work published? .....
- 1.2.1. If the work was published prior to registration for your research degree, give a brief rationale for its inclusion  
.....  
.....  
.....
- 1.3. Was the work subject to academic peer review? .....
- 1.4. Have you retained the copyright for the work? **Yes / No**  
If yes, please attach evidence of retention.  
If no, or if the work is being included in its published format, please attach evidence of permission from copyright holder (publisher or other author) to include work

**2. For a 'research paper' prepared for publication but not yet published**

- 2.1. Where is the work intended to be published? *Antimicrobial Agents and Chemotherapy*
- 2.2. Please list the paper's authors in the intended authorship order *Henriques G, van Schaik W, DA, Burrow R, Warhurst DC, Thompson E, Baker DA, Hallett R, Fidock DA, Fiebeck, Sutherland C.*
- 2.3. Stage of publication – Not yet submitted / Submitted / Undergoing revision from peer reviewers' comments / In press

**3. For multi-authored work, give full details of your role in the research included in the paper and in the preparation of the paper. (Attach a further sheet if necessary)**

*I performed the experiments, analyzed data and drafted the paper.*

NAME IN FULL (Block Capitals) *GISELA CRISTINA LOURENÇO HENRIQUES*

STUDENT ID NO: *298382*

CANDIDATE'S SIGNATURE *Gisela Henriques* Date *28/08/2014*

SUPERVISOR/SENIOR AUTHOR'S SIGNATURE (3 above) *Colin Hill* *27<sup>th</sup> Aug 2014*



**ABSTRACT**

The emergence of drug-resistant parasites is a serious threat faced by malaria control programmes. Understanding the genetic basis of resistance is critical to the success of treatment and intervention strategies. A novel locus associated with antimalarial resistance, *pcap2-mu* (encoding the mu chain of the AP2 adaptor complex), was recently identified in studies on the rodent malaria parasite *Plasmodium chabaudi*. Furthermore, analysis in Kenyan malaria patients of polymorphisms in the *Plasmodium falciparum* homologue *pfap2-mu* found evidence that differences in the amino acid encoded by codon 160 are associated with enhanced parasite survival *in vivo* following combination treatments which included artemisinin derivatives. Here we characterize the role of *pfap2-mu* in mediating the *in vitro* antimalarial drug response of *P. falciparum* by generating transgenic parasites constitutively expressing either the wild-type Ser160 or the 160Asn mutant form of *pfap2-mu*. Transgenic parasites carrying the *pfap2-mu* 160Asn allele were significantly less sensitive to dihydroartemisinin using a standard 48-hour *in vitro* test, providing direct evidence of an altered parasite response to artemisinin. Our data also provide evidence that *pfap2-mu* variants can modulate parasite sensitivity to quinine. No evidence was found that *pfap2-mu* variants contribute to the slow clearance phenotype exhibited by *P. falciparum* in Cambodian patients treated with artesunate monotherapy. These findings provide compelling evidence that *pfap2-mu* can modulate *P. falciparum* responses to multiple drugs. We propose that this gene should be evaluated further as a potential molecular marker of antimalarial resistance.

## INTRODUCTION

Antimalarial drugs remain indispensable tools in the fight against malaria. The potent artemisinin derivatives, combined with longer half-life partner drugs, are the only efficacious treatments left for multidrug-resistant *P. falciparum*, and thus form the cornerstone of antimalarial drug therapy. The emergence of drug resistance represents one of the most serious problems faced by malaria control programmes. Historically, parasite resistance to antimalarial medicines has emerged in Southeast Asia and eventually spread towards Africa and, alarmingly, there is already evidence of reduced susceptibility of *P. falciparum* to artemisinin derivatives in Southeast Asia, as evidenced by delayed parasite clearance times *in vivo* (1-4). For now, the delayed clearance phenotype appears to be confined to the Greater Mekong sub region (5); however, this reduced artemisinin sensitivity may spread to other regions or independently arise elsewhere, including Africa, where the burden of malaria is highest and where the emergence of resistance would have a terrible impact. A better understanding of mechanisms of artemisinin resistance would be a major advance in our ability to develop and validate new tools for resistance surveillance. These are essential tools to guide national treatment policies and help the design and deployment of new drug combinations that may deter the emergence and spread of resistance.

Mutations within the k13 kelch propeller domain gene (*pfk13*) recently identified in Cambodian parasite populations have been proposed as a molecular marker of artemisinin resistance (6). Nevertheless, other genes acting together with *pfk13* in Cambodia are likely to be involved in the slow clearance phenotype, and k13-independent mechanisms may have arisen in other settings. Other potential genetic markers of artemisinin resistance have previously been identified using genome-wide sequencing of drug-pressured mutants of the rodent malaria parasite *Plasmodium chabaudi* (7). One of these, the gene encoding the mu subunit of the adaptor protein 2 (AP2) complex involved in clathrin-mediated endocytosis, exhibits polymorphism in *P. falciparum* isolates from Africa (8).

We recently reported a phenomenon of sub-microscopic persistent parasites at day 3 following treatment with artemisinin combination therapy in Kenyan children. These persistent parasites were only detectable by qPCR but the children carrying these parasites had a higher mosquito transmission potential and were more likely to go on to classical treatment failure at day 28 or 42 post-treatment (9). Sequence analysis of these parasites revealed a particular genotype, combining variants of the *pfcr1*, *pfmdr1*, *pfap2-mu* and

*pfubp1* candidate drug-resistance genes, which may modulate the responses to artemisinin combination treatments (10). This study specifically demonstrated that a Ser160Asn/Thr mutation in the *P. falciparum ap2-mu* gene was a modulator of *in vivo* responses to artemisinin derivatives in Kenyan malaria patients, being significantly more common among sub-microscopic parasites surviving combination treatment at day 3 than in the pre-treatment population.

To explore the role of this putative artemisinin resistance marker, we have generated transgenic *P. falciparum* parasites expressing an extra copy of either the wild-type (WT) *pfap2-mu* gene or the 160Asn form, driven by a heterologous promoter, in addition to their endogenous WT *pfap2-mu* gene. The susceptibility of these parasites to several antimalarial drugs (dihydroartemisinin, quinine, chloroquine, lumefantrine, mefloquine and atovaquone) was compared to the parental Dd2<sup>attB</sup> strain in a classical 48 hour growth inhibition assay. Dihydroartemisinin susceptibility of the parasites was further evaluated using two alternative assays, a 6 hour pulsing assay established specifically for this study and the recently described ring-stage survival assay (RSA) (11).

## MATERIALS AND METHODS

### Culture of *Plasmodium falciparum*

The Dd2<sup>attB</sup> clone of *P. falciparum* was generated by integration of the acceptor *attB* site, derived from mycobacteriophage bxb1, into the non-essential glutaredoxin-like gene located within the cg6 locus of chromosome 7. Drug selection with 5nM WR99210 was applied throughout, to maintain the presence of this site as described (12). Parasite cultures were maintained in complete growth medium composed of RPMI 1640 growth medium supplemented with 2.5% (v/v) human AB serum, 147µM hypoxanthine, 5g/l Albumax II (Invitrogen), 10mM D-glucose and 2mM L-glutamine at 2% haematocrit in 5% CO<sub>2</sub> at 37°C. Parasite cultures were synchronized at the ring stage using sequential D-sorbitol lysis treatment (13). Where not listed, reagents were obtained from Sigma-Aldrich.

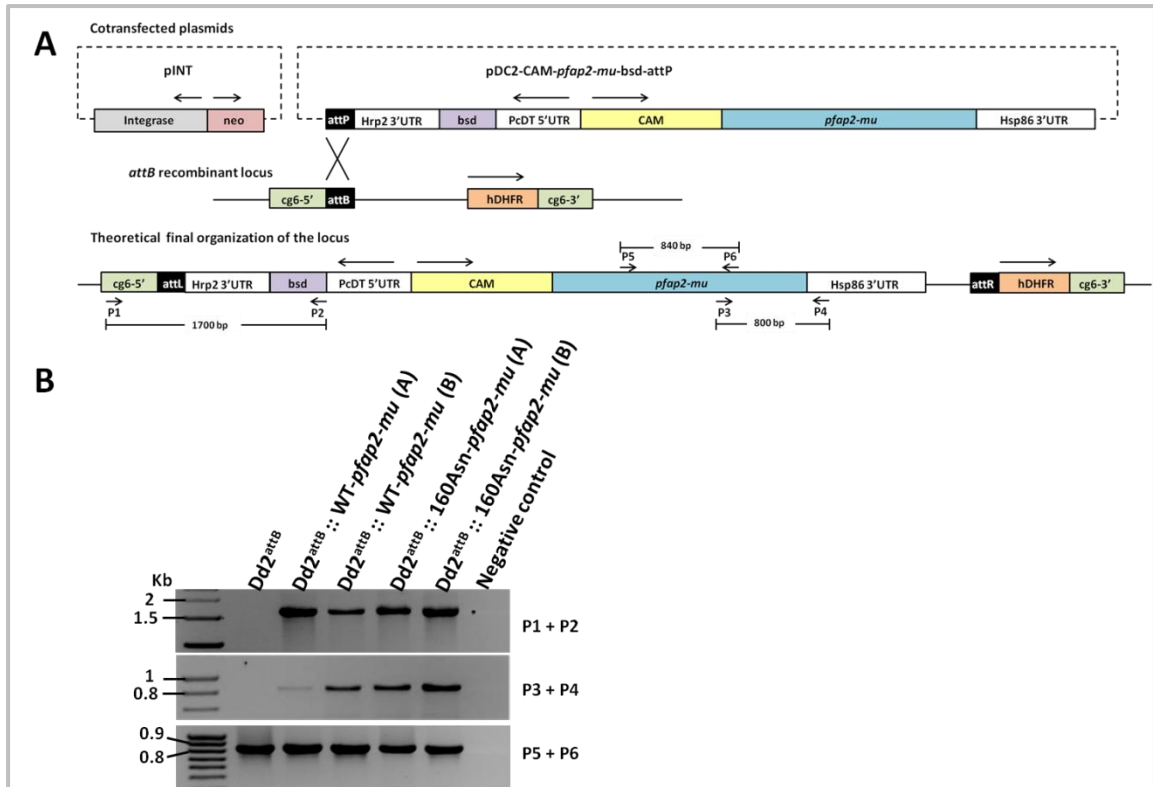

**Figure 1.** Site specific integration of *pfap2-mu* gene (WT and 160Asn) into the *P. falciparum* Dd2<sup>attB</sup> line. **(A)** Schematic diagram of the integrase-mediated *attB* x *attP* recombination approach (Nkrumah et al., 2006). The top panel shows the cotransfected plasmids: plasmid pINT, carrying the integrase expression unit that catalyses the recombination, and the neomycin resistance cassette (neo); and the pDC2-CAM-*pfap2-mu*-bsd-attP plasmid carrying the WT or a mutant 160Asn *pfap2-mu* gene sequence under the control of the calmodulin promoter, a blasticidin resistance cassette (bsd) and the *attP* site. The middle panel shows the recipient *cg6-attB* recombinant locus present in Dd2<sup>attB</sup>. The *attB* x *attP* recombination generates two sites, *attL* (left) and *attR* (right). The hDHFR represent the drug selection markers for WR99210. The lower panel represents the integration of the pDC2-CAM-*pfap2-mu*-bsd-attP plasmid into the *cg6-attB* locus of Dd2<sup>attB</sup>. The position and orientation of the PCR primers (P1 to P6) used in the analysis of the transgenic parasites are shown. **(B)** PCR monitoring of integration of pDC2-CAM-*pfap2-mu*-bsd-attP plasmid on the transfected parasites (two independent transfection experiments, A and B, for the Wt and the 160Asn mutant). The Dd2<sup>attB</sup> DNA was used as a control. The top panel shows integration of the blasticidin cassette into the *attB* recombinant locus using the primers P1 and P2 (expected fragment size: 1700 bp). The middle panel shows the presence of the *pfap2-mu*-hsp86 3'UTR fusion (using the P3 and P4 primers; expected fragment size 800 bp). The bottom panel shows the PCR product used to confirm the presence of the 160Asn mutation by sequencing (using the P5 and P6 primers; expected fragment size: 840 bp).

### Generation of *P. falciparum* transfection constructs

The open reading frames of both the wild-type and mutant (160Asn) allele of the *pfap2-mu* gene (PlasmoDB identifier: PF3D7\_1218300) were amplified, respectively, from genomic DNA of *P. falciparum* parasite line 3D7 and from a *P. falciparum* field sample previously shown to harbour the 160Asn mutation (10). The PCR primers used are

described in Supplementary Table S1. Plasmids pDC2-*cam-pfap2-mu*-attP and the pDC2-*cam-pfap2-mu*<sub>160Asn</sub>-attP were then engineered (Fig. 1A). The *pfap2-mu* amplicons were cloned as *AvrII/XhoI* fragments between the *calmodulin* (PF3D7\_1434200) promoter and the *hsp86* (PF3D7\_0708500) 3' UTR in the pDC2 vector (14) which also encodes a blasticidin-S deaminase (*bsd*) selectable marker cassette. The resulting constructs were verified by sequence analysis and DNA for transfection was purified using the Qiagen CompactPrep Plasmid Maxi Kit.

For each duplex transfection, 50µg of the plasmid containing the attP site together with the *pfap2-mu* gene (WT or the 160Asn copy) and 50µg of the pINT plasmid containing the integrase expression unit that catalyses the recombination, and the neomycin resistance cassette (each in 25µl TE buffer) were resuspended in 350µl cytomix [120mM KCl, 0.15mM CaCl<sub>2</sub>, 2mM EGTA (pH 7.6), 5mM MgCl<sub>2</sub>, 10mM K<sub>2</sub>HPO<sub>4</sub>/KH<sub>2</sub>PO<sub>4</sub> (pH 7.6) and 25mM HEPES (pH 7.6)].

### ***Plasmodium falciparum* transfections**

Transfections of *P. falciparum* were carried out as described by Adjalley and colleagues (15), with slight modifications. Briefly, 250µL of synchronized ring stage Dd2<sup>attB</sup> infected erythrocytes at 6-9% parasitaemia, was added to 400µL of the duplex plasmid preparation in electroporation cuvettes (Bio-Rad). Parasites were transfected by electroporation (0.31 kV, 950µF and infinite resistance; Bio-Rad Gene Pulser XCell) and then immediately transferred to culture flasks containing 10ml of complete medium and 500µl of newly harvested red blood cells. Transfectants were allowed to recover in drug-free medium for 24 hours and then selected with 2.5µg/ml blasticidin (Sigma-Aldrich) and 125µg/ml of G418 (Invitrogen, Life Technologies). Drug pressure with G418, selecting for the pINT plasmid, was applied for six days. The medium was changed daily for the first six days, and then every other day with fresh medium containing the blasticidin and WR99210 selection agents. Cultures were diluted 3:5 weekly (by the addition of 30% fresh blood cells) and monitored by Giemsa staining every 4-5 days for appearance of the transfected parasites. Drug pressure was maintained until the correct integration at the genomic *attB* locus was verified by PCR. Two independent transfections for each *pfap2-mu* plasmid were carried out.

Correct integration was verified by PCR using the P1/P2 primer pair (Figure 1, Table 1). The presence of the *pfap2-mu* gene with the *hsp86* 3'UTR and the *pfap2-mu* gene was also monitored using the P3/P4 and the P5/P6 primer pairs, respectively (Figure 1, Table 1).

Sequence analysis of the mutation site G479A (160Asn) was performed using the P5/P6 primer pair.

**Table 1.** Primer sequences used in vector construction and integration confirmation

Primer	Sequence (5' – 3')	Description
C1	CGTAACTAGTATGATCGATGCGCTGTACAT	Amplification of the <i>pfap2-mu</i> ORF (Forward)
C2	ATGCCTCGAGCTATTTATACTGGTAGATGCC	Amplification of the <i>pfap2-mu</i> ORF (Reverse)
P1	CCAGGATCCAAAAGAAGGAGGAGG	Confirming integration of the bsd cassette into the <i>attB</i> recombinant locus (Forward)
P2	ATGCATGCCAAGCCTTTGTCTCAAG	Confirming integration of the bsd cassette into the <i>attB</i> recombinant locus (Reverse)
P3	GCATATTTTCATCATTGTGTTACC	Confirming the presence of the <i>pfap2-mu</i> -Hsp86 3'UTR fusion (Forward)
P4	GGGGTGATGATAAAATGAAAGATA	Confirming the presence of the <i>pfap2-mu</i> -Hsp86 3'UTR fusion (Reverse)
P5	GATATCCACAAACATTAGAAGTG	Confirming the presence of the <i>pfap2-mu</i> gene (Forward)
P6	CCATCTGGTGGTGTGAAGG	Confirming the presence of the <i>pfap2-mu</i> gene (Reverse)

### RNA extraction and cDNA preparation

For total RNA isolation, parasitized red cells were rapidly lysed in TRI Reagent (Sigma-Aldrich) and then stored at -80°C prior to RNA extraction, which followed the manufacturer's protocol as previously described (16). Briefly, the TRI Reagent lysates were thawed at 37°C, 0.4ml of chloroform (Sigma-Aldrich) added, and the mixture was vigorously mixed and incubated 15 minutes at room temperature before centrifugation (12,000xg, for 15 minutes at 4°C). The aqueous phase was precipitated with 0.5ml of isopropanol (Sigma-Aldrich), incubated for 10 minutes at room temperature and centrifuged (12,000xg, for 10 minutes at 4°C) to allow RNA precipitation, and the pellet washed with 75% ethanol (Sigma-Aldrich). The samples were stored at 4°C overnight and then centrifuged at 12,000xg, for 10 minutes at 4°C. The ethanol was removed and the RNA pellet was air-dried, before being resuspended in 20µl of nuclease free water (Promega).

Extracted RNA was treated with RQ1 ribonuclease-free deoxyribonuclease (Promega) and reverse transcribed using gene specific primers (Q2 and Q3; Table 2) and the GoScript reverse transcriptase kit (Promega), as described by the manufacturer. Each

nuclease-treated preparation was then split in two. In the control tubes reverse transcriptase was replaced with water (DNA contamination control).

**Table 2.** Primer sequences used in quantitative RT-PCR on *P. falciparum* mRNA

Primer	Sequence (5' – 3')	Description
Q1	GGAAAGGTAACCTTAAAATGTC	<i>pfap2-mu</i> amplification (Forward)
Q2	GTTACTACCGGCGAGAATATT	<i>pfap2-mu</i> amplification (Reverse) and cDNA synthesis
Q3	TGAAAGCAGCGTAGCTCAGA	tRNA amplification (Forward)
Q4	CGCGTGGTTTCGATCCACG	tRNA amplification (Reverse) and cDNA synthesis

### Quantitative RT-PCR on ring stage and late stage samples of *P. falciparum* mRNA

Quantitative RT-PCR (RT-qPCR) was performed using QuantiTect SYBR Green PCR Kit (Qiagen) in a Rotor-Gene RG3000 machine (Corbett Research). Transcripts of the *pfap2-mu* gene were amplified using the Q1/Q2 primer pair (Table 2) and the *Plasmodium* tRNA methionine (*PgMET*) gene was used as a reference source of RNA. Previously published primer sequences Q3/Q4 (Table 2) were used to amplify the *pgmet* gene as described (17). Reactions were carried out in 25µl volumes using QuantiTect SYBR Green PCR master mix according to the manufacturer's guidelines. The PCR cycles used were 95°C for 6 minutes followed by 40 cycles of 95°C for 15 seconds and 60°C for 1 minute, for all reactions. Each parasite RNA sample was tested in triplicate in each experiment. Relative expression of *pfap2-mu* was calculated from the average threshold cycle (*CT*) values from two experiments, normalized to *pgmet*, using the  $\Delta\Delta^{CT}$  method, where the parental line was used as the comparator.

### Standard 48 hour drug susceptibility assays

Standard 48 hour drug exposure assays were performed to determine the susceptibility of parasites to dihydroartemisinin (DHA), quinine, chloroquine, lumefantrine, mefloquine and atovaquone according to protocols using the intercalating dye PicoGreen to provide a fluorescent signal, as previously deployed in our laboratory (18). The resulting  $IC_{50}^{48h}$  estimates were used as primary indicators of anti-malarial susceptibility, determined from a log-dose response analysis using the Prism v6.04 (GraphPad Software, Inc., San Diego, CA). Each assay was performed with two replicates on at least two (range 2 – 6)

independent occasions for each drug. For statistical analysis best-fit estimates of the  $IC_{50}$  and their 95% confidence intervals were obtained by nonlinear regression fitting of the sigmoidal dose response curve for each drug across all experiments, after normalisation using control well fluorescent signals. For statistical comparison of each transgenic with the parental curve and comparison between the two transgenic curves, data were first fitted independently and then globally to find a shared best-fit value for the  $IC_{50}^{48h}$ . Results were compared by a sum-of-squares *F*-test.

### **Artemisinin 6 hour pulse assays**

To generate  $IC_{50}^{6h}$  estimates for artemisinin, we devised an alternative *in vitro* drug susceptibility protocol. DHA was serially diluted in complete medium (250 $\mu$ l) in Eppendorf tubes, using the same ten concentrations generated for the standard 48 hour drug assays. 250 $\mu$ l of ring stage culture was added to each drug dilution (2% final hematocrit and 0.5% final parasitemia) and incubated at 37°C for 6 hours. After the incubation time half of the culture was placed in a 96-well tissue culture plate (modified 48 hour assay) and the other half was washed three times with 1000 $\mu$ l of RPMI, to remove dihydroartemisinin, before being replenished with drug free medium and placed in the 96-well culture plate. The plate was then incubated at 37°C for 42 hours until growth assessment using the PicoGreen detection method, as described for the standard 48 hour assays, generating a measure of DHA sensitivity in the form of an  $IC_{50}^{6h}$  estimate.

### **Ring stage survival assays (RSA)**

The RSA was performed as described by Witkowski and colleagues (11) with minor modifications. The parasite cultures were tightly synchronized across two consecutive ring stage cycles with sorbitol treatment. Late schizont stage parasites cultures were enriched using MACS separation columns (Miltenyi Biotech GmbH) and were cultured for 3 hours at 37°C with fresh erythrocytes, and again sorbitol-treated. This early ring stage (0-3 hours) parasite preparation, at 1% parasitaemia, 2% haematocrit in 2ml final volume, was then exposed for 6 hours to 700nM of dihydroartemisinin in 0.1% DMSO. After the 6 hour exposure the cultures were washed and resuspended in drug-free culture medium and cultured at 37°C for a further 66 hours. Dihydroartemisinin susceptibility was then assessed microscopically on thin films by estimating the percentage of viable parasites that had developed into a new generation of trophozoites, 66 hours after dihydroartemisinin exposure, compared to parasites exposed to 0.1% DMSO alone.



## RESULTS

### Generation of transgenic parasites by integration of an additional copy of *pfap2-mu* in Dd2<sup>attB</sup>

To investigate the potential role for the *pfap2-mu* 160Asn mutation in mediating reduced *in vitro* susceptibility of *P. falciparum* to antimalarial drugs, we generated transgenic parasites with an additional copy of either the wild-type Ser160 or the 160Asn mutant form of *pfap2-mu* gene. This was achieved using Bxb1 mycobacteriophage integrase-mediated recombination to deliver transgenes into the *P. falciparum* genome in a site-specific manner dictated by the presence in the parental line Dd2<sup>attB</sup> of the *attB* target sequence, replacing the *cg6* locus (12). The *pfap2-mu* gene, with or without the 160Asn mutation, was cloned into the pDC2 plasmid under the control of the calmodulin promoter (Fig 1A), and cotransfected into Dd2<sup>attB</sup> strain with the pINT plasmid (encoding integrase) (12). After transfection the parasites were placed under drug selection with both blasticidin and G418, generating two transgenic lines termed Dd2<sup>attB</sup>::WT-*pfap2-mu* and Dd2<sup>attB</sup>::160Asn-*pfap2-mu*. Stably transfected parasites were obtained two to three weeks after transfection and diagnostic PCR using P1/P2 specific primers (Fig. 1 A; Table 1) revealed correct integration into the *attB* site. The presence of the *pfap2-mu* transgenes was confirmed by PCR analysis (Fig. 1 B; Table 1) and the presence of the 160Asn mutation in the Dd2<sup>attB</sup>::160Asn-*pfap2-mu* line was confirmed by sequencing.

### RT-qPCR analysis of *pfap2-mu* in transgenic lines

Quantitative RT-qPCR analysis of cultures of the parental and transfected parasite lines provided evidence of constitutive blood-stage expression of the introduced transgenes. In ring stage cultures, 7.9-fold (160Asn-*pfap2-mu*) and 23.8-fold (WT-*pfap2-mu*) over-expression of *pfap2-mu* mRNA was found in the transfectant lines compared to the parental, reflecting the known expression profile of the calmodulin promoter, but late stage cultures of both transfectant lines exhibited mRNA levels similar to those of Dd2<sup>attB</sup> (Fig. 2). For each sample, parallel reactions prepared without reverse transcriptase did not generate detectable amplicons within 35 cycles, demonstrating the absence of detectable genomic DNA contaminating the RNA (data not shown). Total RNA prepared from the peripheral blood of a malaria patient as part of a previous study (18) was also analysed, and confirmed transcription of *pfap2-mu* by circulating *P. falciparum* blood stages *in vivo*.

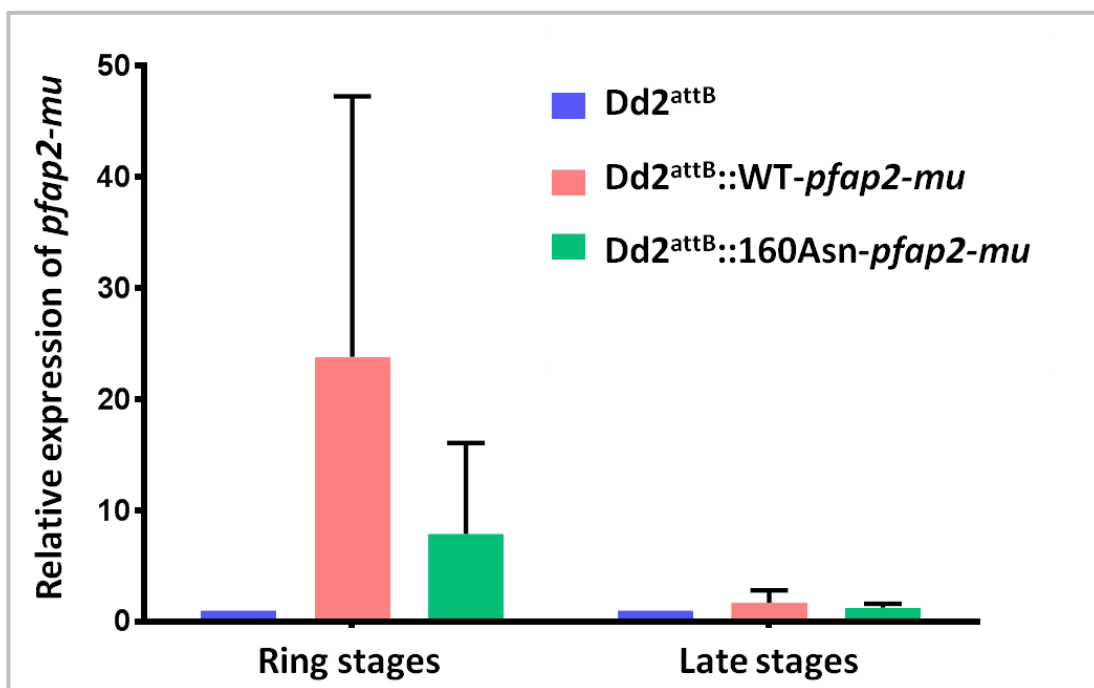
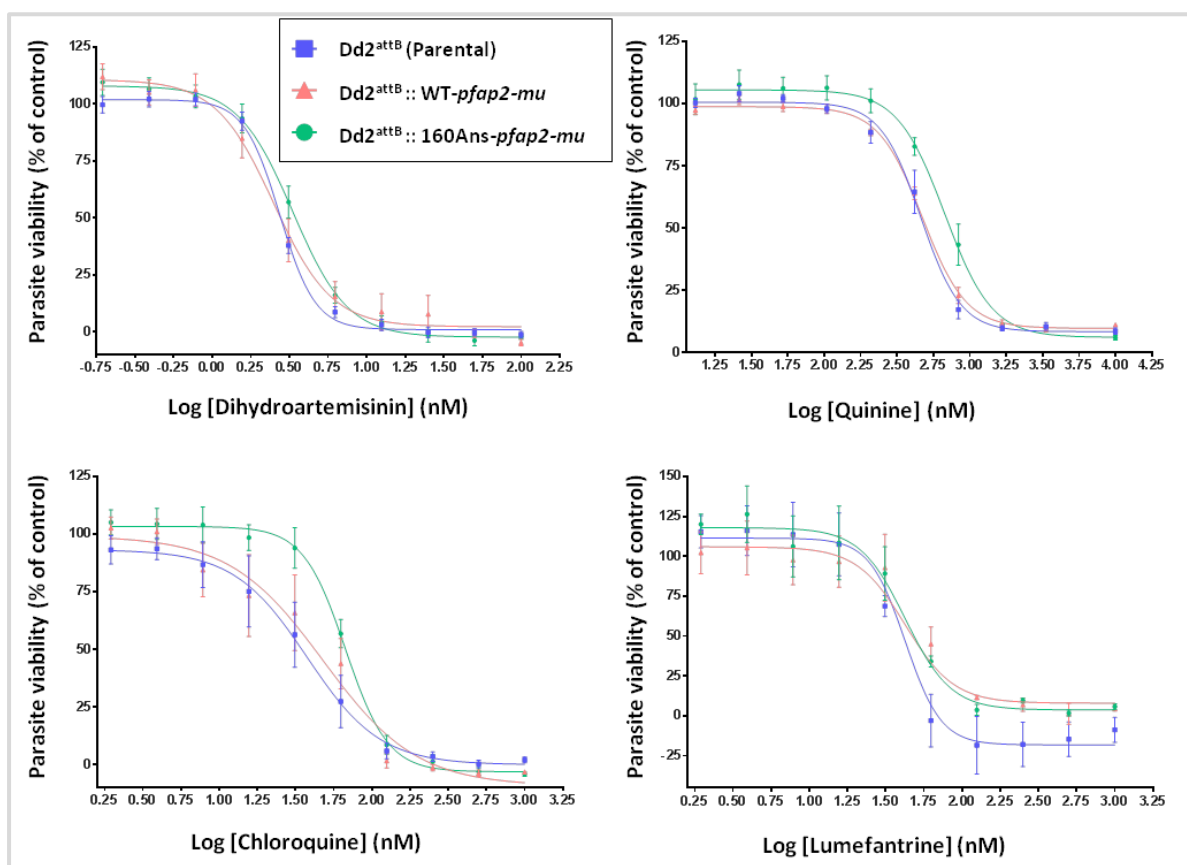

**Figure 2.** Expression levels of *pfap2-mu* transcripts on ring and late stage (trophozoites and schizonts) cultures of Dd2<sup>attB</sup>, Dd2<sup>attB</sup>::WT-*pfap2-mu* and Dd2<sup>attB</sup>::160Asn-*pfap2-mu* lines. Mean mRNA expression level of *pfap2-mu* in Dd2<sup>attB</sup> and transfected lines from RT-qPCR analysis. The expression of *pfap2-mu* was normalized to the mRNA level of PgMET. Error bars indicate standard deviations.

### ***In vitro* sensitivity of *pfap2-mu* transfectant parasites**

The growth inhibition curves for dihydroartemisinin, quinine, chloroquine and lumefantrine for both transgenic lines are presented in Figure 3. Table 3 shows the mean ( $\pm$  standard deviation) IC<sub>50</sub><sup>48h</sup> estimates calculated for the parental and transfected lines and the significance of any differences in sensitivity between the different lines. In four independent experiments, the transgenic parasite line harbouring the 160Asn copy of the *pfap2-mu* gene displayed a significantly reduced sensitivity to DHA (mean IC<sub>50</sub><sup>48h</sup> = 3.3 nM) when compared with both the parent line (mean IC<sub>50</sub><sup>48h</sup> = 2.7 nM) and WT-*pfap2-mu* (mean IC<sub>50</sub><sup>48h</sup> = 2.5 nM) lines (Table 3). Quinine IC<sub>50</sub><sup>48h</sup> increased significantly from 459.2 nM in the parental line and from 471.5 nM in the WT-*pfap2-mu*, to 671.2 nM in the 160Asn-*pfap2-mu* parasite line. The presence of 160Asn-*pfap2-mu* also led to reduced susceptibility to chloroquine, when compared with the parental line, whereas the WT transfected line exhibited an intermediate phenotype, not statistically different from either the parental or mutant transgenic lines. Thus decreased sensitivity to DHA, quinine and chloroquine was conferred in these experiments by the presence of the 160Asn *pfap2-mu* mutant allele

given that the overexpression of the WT allele had no effect on parasite susceptibility to these antimalarials. In contrast, the  $Dd2^{attB}::WT-pfap2-mu$  line showed significantly reduced susceptibility to lumefantrine,  $IC_{50}$  57.7 nM, when compared with the parental line,  $IC_{50}$  36.1 nM. No significant difference was found between the WT and the 160Asn lines, nor between the 160Asn and the parental lines. The presence of the 160Asn-*pfap2-mu* did not significantly alter parasite susceptibility to atovaquone, a drug with a well-known mitochondrial mode of action that is unrelated to that of the artemisinins and aminoquinolines, nor to mefloquine (Table 3).



**Figure 3.** Dose response curves of the  $Dd2^{attB}$  (Parental),  $Dd2^{attB}::WT-pfap2-mu$  and  $Dd2^{attB}::160Asn-pfap2-mu$  strains to dihydroartemisinin, quinine, chloroquine and lumefantrine. The drug sensitivity of the parasites was assessed using a standard 48h assay. Each point represents the mean of at least two independent experiments, with two replicates for each experiment. The error bars indicate  $\pm$  standard errors of the means. Best-fit curves were generated by Prism v6.04. The X axis indicates the increasing concentration of the different drugs and the Y axis indicates the parasite viability.

**Table 3: *In vitro* drug susceptibility of the Dd2<sup>attB</sup> (Parental), Dd2<sup>attB</sup> :: WT-*pfap2-mu* and Dd2<sup>attB</sup> :: 160Asn-*pfap2-mu* transfectant strains to six antimalarial drugs.** The drug sensitivity of the parasites was assessed using a classic 48h growth inhibition assay. The best-fit curve for each drug was generated in Prism v6.04 and the best-fit estimate of the IC<sub>50</sub> and their 95% confidence intervals are indicated in the table.

Drug	Dd2 <sup>attB</sup> (Parental)		Dd2 <sup>attB</sup> :: WT- <i>pfap2-mu</i>		P-value*	Dd2 <sup>attB</sup> :: 160Asn- <i>pfap2-mu</i>		P-value	P-value
	N <sup>a</sup>	IC <sub>50</sub> (nM) [95% CI]	N	IC <sub>50</sub> (nM) [95% CI]	WT Vs Dd2 <sup>attB</sup>	N	IC <sub>50</sub> (nM) [95% CI]	160Asn Vs Dd2 <sup>attB</sup>	WT Vs 160Asn
Dihydroartemisinin	4	2.7 [2.6-2.9]	4	2.5 [2.0-3.1]	0.371	4	3.3 [2.9-3.8]	<b>0.0057</b>	<b>0.0227</b>
Quinine	3	459.2 [413.3-510.3]	3	471.5 [442.1-502.9]	0.683	3	671.2 [582.3-773.6]	<b>&lt;0.0001</b>	<b>&lt;0.0001</b>
Chloroquine	4	37.6 [25.9-54.5]	4	48.0 [29.6-78.0]	0.445	3	67.1 [58.6-76.8]	<b>0.0028</b>	0.1429
Lumefantrine	2	36.1 [28.3-46.2]	2	57.7 [43.0-77.4]	<b>0.0294</b>	2	44.8 [32.3-62.1]	0.3028	0.2517
Mefloquine	6	13.1 [10.3-16.7]	6	16.7 [13.9-19.9]	0.1416	6	17.0 [13.6-21.2]	0.1488	0.8829
Atovaquone	4	2.7 [2.3-3.4]	4	2.8 [2.3-3.5]	0.923	4	4.0 [2.7-6.0]	0.1014	0.1127

<sup>a</sup>N – Number of independent experiments, each experiment had two replicates;

P-value\* – The sum-of-squares *F*-test was used to test the significance of difference among the IC<sub>50</sub> values of the different parasites. The significant P-values are indicated in bold

The 6 hour drug pulse assay, developed to better reflect the short exposure times to artemisinin that occur *in vivo*, was used to estimate DHA  $IC_{50}^{6h}$  for parental and transgenic lines. Figure 4 shows the best-fit curves generated and  $IC_{50}^{6h}$  estimates are indicated in table 4. The survival curves obtained in the 6 hour pulse assay showed a rightward shift towards higher dihydroartemisinin concentrations compared with the survival curves obtained in the modified 48 hour assay (ie with a 6 hour tube incubation prior to plating; see Methods). These curve shifts meant that DHA  $IC_{50}^{6h}$  estimates were always higher than the  $IC_{50}^{48h}$ , by approximately 2-fold. Nevertheless, no significant difference was found between the transfectant and the parental lines using either the  $IC_{50}^{48h}$  or  $IC_{50}^{6h}$  estimates (Table 4). The  $IC_{50}$  values obtained in the modified 48 hour assay were slightly higher (range: 3.9 to 4.1nM) than the ones obtained in the standard 48 hour assay (range: 2.5 to 3.3nM), possibly due to differences in drug exposure arising from the initial 6 hour incubation in microcentrifuge tubes.

The susceptibility of young ring stage (0-3 hour) cultures to a 6 hour pulse with 700nM of DHA was evaluated using the RSA of Witkowski *et al.* (11). Parasite viability was zero, defined as more than 99% of parasites recorded as dead at 72 hours, in all test wells (data not shown), indicating that parental and transgenic lines were fully susceptible to DHA by this test.

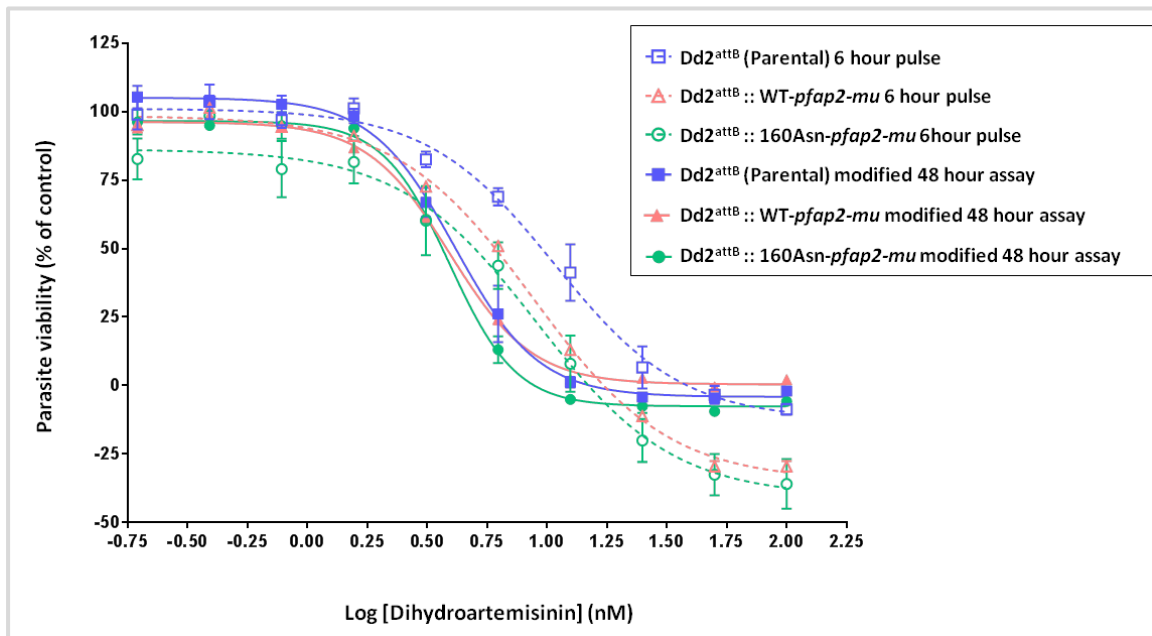

**Figure 4.** Dose response curves of the  $Dd2^{attB}$  (Parental),  $Dd2^{attB} :: WT-pfap2-mu$  and  $Dd2^{attB} :: 160Asn-pfap2-mu$  transfectants to Dihydroartemisinin. The drug sensitivity of the parasites was assessed using a modified 48 hour assay (solid line) and 6 hour pulse assay (dashed line). Each point represents the mean of two independent experiments, with two replicates for each experiment. The error bars indicate  $\pm$  standard errors of the means. Best-fit curves were generated by Prism v6.04. The X axis indicates the increasing concentration of dihydroartemisinin and the Y axis indicates the parasite viability.

**Table 4** *In vitro* drug susceptibility of the Dd2<sup>attB</sup> (Parental), Dd2<sup>attB</sup> :: WT-*pfap2-mu* and Dd2<sup>attB</sup> :: 160Asn-*pfap2-mu* transfectant strains to dihydroartemisinin using a 6h pulse assay. The best-fit curves were generated in Prism v6.04 and the best-fit estimate of the IC<sub>50</sub> and their 95% confidence intervals are indicated in the table. The sum-of-squares F-test did not show any significant difference between the IC<sub>50</sub>

	IC <sub>50</sub> (nM) [95% CI]	
	Modified 48h assay *	6h pulse assay *
Dd2 <sup>attB</sup> (Parental)	4.1 [3.7-4.6]	10.8 [8.6-13.5]
Dd2 <sup>attB</sup> :: WT- <i>pfap2-mu</i>	3.9 [3.8-4.1]	8.8 [8.1-9.4]
Dd2 <sup>attB</sup> :: 160Asn- <i>pfap2-mu</i>	3.9 [3.6-4.2]	9.1 [6.3-13.1]

\* The dihydroartemisinin susceptibility of each parasite line was assessed in both assays by two independent experiments, with two replicates for each experiment.

## DISCUSSION

In this study we aimed to better understand the role of the *ap2-mu* gene in mediating *P. falciparum* drug responses. *Pfap2-mu* was first implicated in artemisinin resistance in the rodent malaria parasite *P. chabaudi* through whole-genome sequencing of a parasite lineage resistant to artemisinin, which identified a novel Ile568Thr change as responsible for this phenotype by genome-wide association analysis (8). Several variants of this gene were identified in *P. falciparum*, but a polymorphism homologous to *P. chabaudi* Ile568Thr has not been detected in field isolates to date (8, 10). However, our recent work conducted in Kenya provides evidence that a Ser160Asn/Thr mutation can modulate the parasite response to artemisinin combination treatments *in vivo* (10). Consistent with these results, we now show that transgenic parasites carrying 160Asn *pfap2-mu* are significantly less susceptible to dihydroartemisinin *in vitro*, manifest as a 32% increase in DHA IC<sub>50</sub>, compared to transgenic parasites carrying an additional copy of the wild-type *pfap2-mu* locus, using a standard 48 hour drug susceptibility testing protocol (18). In addition, this study shows that changes in *pfap2-mu* sequence (for quinine and chloroquine) or expression level (for lumefantrine) also affect parasite sensitivity to other antimalarials *in*

*vitro*. Further experiments are needed to confirm that the higher early stage mRNA expression measured here is accompanied by an increased expression of the corresponding protein, but await the development of suitable reagents (i.e. specific antibodies). Additionally, it will be important to compare *in vitro* susceptibility of the transgenic parasites to that of Cambodian parasite lines with known clearance time phenotypes in both 48-hour exposure dose-response assessment, generating IC<sub>50</sub> estimates, and in the RSA<sub>0-3h</sub> assay.

The *pfap2-mu* gene is predicted to encode the mu ( $\mu$ ) subunit of the adaptor protein 2 (AP2) complex. AP2 facilitates formation of clathrin-coated vesicles, for the trafficking of cargo from one membrane compartment of the cell to another, by recruiting a number of other proteins to the forming vesicle (19). AP2 is located at the parasite plasma membrane and also contributes to the selection of specific cargo (20). The mu subunit binds to the cytoplasmic side of cargo molecules through recognition of specific signals and is incorporated into the mature clathrin-coated vesicle (21), suggesting that AP2-mu variants may influence drug resistance by modulating cargo trafficking (8). The precise mechanism by which polymorphisms in *pfap2-mu* affect antimalarial drug response remains unknown. The *P. chabaudi* Ile568Thr mutation is predicted to lie in the C-terminus of the AP2-mu protein, whereas the Ser160Asn mutation in *P. falciparum* is positioned in the N-terminal domain. Both regions are highly conserved across the genus and, by analogy to studies of mammalian homologues, it is predicted that both codons contribute to  $\beta$ -sheet structure lying within or adjacent to the hydrophobic pocket that binds to the recognition motif present in the cargo protein (8). These mutations may therefore mediate antimalarial drug response by reducing AP2-mu binding affinity to the membrane cargo, and thus decreasing the efficiency of endocytotic trafficking of membrane proteins. A better understanding of AP2 variants requires studies of structure and function of the adaptor complex protein in *Plasmodium* spp.

The phenotype of reduced susceptibility to dihydroartemisinin described in this study is moderate, and unlikely to confer drug resistance in itself; the phenomenon also appears to be significantly different from the slow clearance phenotype described in Southeast Asia, which implicates mutations in the *pfk13* kelch propeller domain. Firstly, the latter is associated with prolonged parasite clearance times *in vivo* and with increased survival in the ring stage parasite survival assay, but not with any change *in vitro* susceptibility to dihydroartemisinin using a standard 48 hour drug assay. Here, the transgenic population carrying the mutant *pfap2-mu* was shown to be significantly less susceptible to

dihydroartemisinin than the parental population, even though the  $IC_{50}$  was only marginally increased; however, this “tolerant” phenotype was not detected using the RSA, and is thus distinct from the phenotype described by Witkowski *et al.* (11). Secondly, contrary to the SE Asian isolates, the persistent Kenyan parasites carrying the Ser160Asn/Thr mutation also carry the chloroquine sensitive haplotype *pfcr1* CVMNK and were microscopically undetectable; to date the *pfk13* genotypes associated with SE Asian reduction in susceptibility have not been seen in Kenyan parasites with the whole genome sequence data currently available (10).

The modulation of artemisinin sensitivity in an African context clearly manifests as a different phenotype from the one described in Cambodia, with different genes and genotypes implicated. In fact, some African slowly clearing infections are not associated with polymorphisms in the kelch protein (4), suggesting the contribution of other genetic factors. Furthermore, drug resistance may not arise in a single step, but as a long and complex process during which parasites become gradually more and more tolerant to the drug. This is believed to be achieved through the stepwise accumulation of genetic changes in the same gene or in different genes (22). Therefore, it is possible that mutations in AP2- $\mu$  are an early step during the development of artemisinin resistance, and that additional genetic changes would be required before a fully resistant parasite genotype has emerged. Alternatively, AP2- $\mu$  may contribute to a broad parasite heterogeneity that modulates the drug response to several antimalarial drugs, as seen for *pfmdr1* and other members of the ABC transporter family in *P. falciparum* (23).

A potential weakness of our study is the sole use of Dd2<sup>attB</sup> (a multidrug resistant line sensitive to artemisinin) as our parent isolate, one that propagates more rapidly than the few other lines available harbouring the *attB* site (14). The genetic background of the parasite can influence the acquisition of drug resistance, so the drug responses observed in this study may vary in isolates with a different pre-existing drug sensitivity background. For example, a significant increase in lumefantrine  $IC_{50}^{48h}$  to 57.7 nM was observed in the Dd2<sup>attB</sup>::WT-*pfap2-mu* transgenic parasites, which is well within the range we have observed in patient isolates tested *ex vivo* (18). However, the highest  $IC_{50}^{48h}$  among these patient isolates occurred in those wild-type for the chloroquine-associated resistance marker *pfcr1*. Additionally, the Dd2<sup>attB</sup> clone of *P. falciparum* was generated by integration of the acceptor *attB* site, into the non-essential glutaredoxin-like gene located within the cg6 locus of chromosome 7. Glutaredoxin-like proteins are proteins involved in the redox homeostasis of the cell (24). Therefore, a parasite lacking the cg6 locus is probably not the



ideal parasite model to study artemisinin resistance given the involvement of this class of drugs on parasite oxidative stress (25, 26). In order to better understand the role of AP2- $\mu$  in drug resistance it is important to perform further genetic studies by performing gene replacement experiments as well as using isolates with different backgrounds, including chloroquine-sensitive genotypes.

In summary, this study shows that constitutive expression of 160Asn *pfap2-mu* in Dd2<sup>attB</sup> altered *P. falciparum* susceptibility to dihydroartemisinin, with transgenic parasites exhibiting significantly higher IC<sub>50</sub><sup>48h</sup> estimates. This confirms *pfap2-mu* as a locus of interest for studies of artemisinin susceptibility. Our data also provide evidence that *pfap2-mu* variants can modulate parasite sensitivity to quinine, chloroquine and lumefantrine *in vitro*.

## ACKNOWLEDGMENTS

We would like to thank Paul Horrocks (Keele University, Staffordshire, UK) for the provision of the Dd2<sup>attB</sup> parasites and Marcus Lee (Columbia University Medical Center, New York, USA) for his expert help. This work was supported by the Fundação para a Ciência e a Tecnologia (FCT) of Portugal (grant number SFRH/BD/63129/2009) and Wellcome Trust Project Grant (Ref 094752) to DAB. CJS is supported by Public Health England. DAF gratefully acknowledges financial support from the NIH (R01 AI109023 and R01 AI50234).

## REFERENCES

1. Noedl H, Se Y, Schaecher K, Smith BL, Socheat D, Fukuda MM. 2008. Evidence of artemisinin-resistant malaria in western Cambodia. *N Engl J Med* 359:2619-2620.
2. Dondorp AM, Nosten F, Yi P, Das D, Phyo AP, Tarning J, Lwin KM, Arie F, Hanpithakpong W, Lee SJ, Ringwald P, Silamut K, Imwong M, Chotivanich K, Lim P, Herdman T, An SS, Yeung S, Singhasivanon P, Day NP, Lindegardh N, Socheat D, White NJ. 2009. Artemisinin resistance in *Plasmodium falciparum* malaria. *N Engl J Med* 361:455-467.
3. Cheeseman IH, Miller BA, Nair S, Nkhoma S, Tan A, Tan JC, Al Saai S, Phyo AP, Moo CL, Lwin KM, McGready R, Ashley E, Imwong M, Stepniewska K, Yi P, Dondorp AM, Mayxay M, Newton PN, White NJ, Nosten F, Ferdig MT, Anderson TJ. 2012. A major genome region underlying artemisinin resistance in malaria. *Science* 336:79-82.

4. Ashley EA, Dhorda M, Fairhurst RM, Amaratunga C, Lim P, Suon S, Sreng S, Anderson JM, Mao S, Sam B, Sopha C, Chuor CM, Nguon C, Sovannaroeth S, Pukrittayakamee S, Jittamala P, Chotivanich K, Chutasmit K, Suchatsoonthorn C, Runcharoen R, Hien TT, Thuy-Nhien NT, Thanh NV, Phu NH, Htut Y, Han KT, Aye KH, Mokuolu OA, Olaosebikan RR, Folaranmi OO, Mayxay M, Khanthavong M, Hongvanthong B, Newton PN, Onyamboko MA, Fanello CI, Tshefu AK, Mishra N, Valecha N, Phyo AP, Nosten F, Yi P, Tripura R, Borrmann S, Bashraheil M, Peshu J, Faiz MA, Ghose A, Hossain MA, Samad R, Rahman MR, Hasan MM, Islam A, Miotto O, Amato R, MacInnis B, Stalker J, Kwiatkowski DP, Bozdech Z, Jeeyapant A, Cheah PY, Sakulthaew T, Chalk J, Intharabut B, Silamut K, Lee SJ, Vihokhern B, Kunasol C, Imwong M, Tarning J, Taylor WJ, Yeung S, Woodrow CJ, Flegg JA, Das D, Smith J, Venkatesan M, Plowe CV, Stepniewska K, Guerin PJ, Dondorp AM, Day NP, White NJ. 2014. Spread of artemisinin resistance in *Plasmodium falciparum* malaria. *N Engl J Med* 371:411-423.
5. WHO. 2014. Status report on artemisinin resistance. World Health Organization.
6. Arieu F, Witkowski B, Amaratunga C, Beghain J, Langlois AC, Khim N, Kim S, Duru V, Bouchier C, Ma L, Lim P, Leang R, Duong S, Sreng S, Suon S, Chuor CM, Bout DM, Menard S, Rogers WO, Genton B, Fandeur T, Miotto O, Ringwald P, Le Bras J, Berry A, Barale JC, Fairhurst RM, Benoit-Vical F, Mercereau-Puijalon O, Menard D. 2014. A molecular marker of artemisinin-resistant *Plasmodium falciparum* malaria. *Nature* 505:50-55.
7. Hunt P, Afonso A, Creasey A, Culleton R, Sidhu ABS, Logan J, Valderramos SG, McNae I, Cheesman S, Rosario Vd, Carter R, Fidock DA, Cravo P. 2007. Gene encoding a deubiquitinating enzyme is mutated in artesunate- and chloroquine-resistant rodent malaria parasites. *Molecular Microbiology* 65:27-40.
8. Beshir KB, Sutherland CJ, Sawa P, Drakeley CJ, Okell L, Mweresa CK, Omar SA, Shekalaghe SA, Kaur H, Ndaro A, Chilogola J, Schallig HD, Sauerwein RW, Hallett RL, Bousema T. 2013. Residual *Plasmodium falciparum* parasitemia in Kenyan children after artemisinin-combination therapy is associated with increased transmission to mosquitoes and parasite recurrence. *J Infect Dis* 208:2017-2024.
9. Henriques G, Martinelli A, Rodrigues L, Modrzynska K, Fawcett R, Houston DR, Borges ST, d'Alessandro U, Tinto H, Karema C, Hunt P, Cravo P. 2013. Artemisinin resistance in rodent malaria--mutation in the AP2 adaptor mu-chain suggests involvement of endocytosis and membrane protein trafficking. *Malar J* 12:118.
10. Henriques G, Hallett RL, Beshir KB, Gadalla NB, Johnson RE, Burrow R, van Schalkwyk DA, Sawa P, Omar SA, Clark TG, Bousema T, Sutherland CJ. 2014. Directional selection at the *pfmdr1*, *pfprt*, *pfubp1* and *pfap2-mu* loci of *Plasmodium falciparum* in Kenyan children treated with ACT. *J Infect Dis*. (Epub July 3, 2014)
11. Witkowski B, Amaratunga C, Khim N, Sreng S, Chim P, Kim S, Lim P, Mao S, Sopha C, Sam B, Anderson JM, Duong S, Chuor CM, Taylor WR, Suon S, Mercereau-Puijalon O, Fairhurst RM, Menard D. 2013. Novel phenotypic assays for the detection of artemisinin-resistant *Plasmodium falciparum* malaria in Cambodia: *in-vitro* and *ex-vivo* drug-response studies. *Lancet Infect Dis* 13:1043-1049.
12. Nkrumah LJ, Muhle RA, Moura PA, Ghosh P, Hatfull GF, Jacobs WR, Jr., Fidock DA. 2006. Efficient site-specific integration in *Plasmodium falciparum* chromosomes mediated by mycobacteriophage Bxb1 integrase. *Nat Methods* 3:615-621.
13. Lambros C, Vanderberg JP. 1979. Synchronization of *Plasmodium falciparum* erythrocytic stages in culture. *J Parasitol* 65:418-420.
14. Adjalley SH, Johnston GL, Li T, Eastman RT, Eklund EH, Eappen AG, Richman A, Sim BK, Lee MC, Hoffman SL, Fidock DA. 2011. Quantitative assessment of *Plasmodium falciparum* sexual development reveals potent transmission-blocking activity by methylene blue. *Proc Natl Acad Sci U S A* 108:E1214-1223.

15. **Adjalley SH, Lee MC, Fidock DA.** 2010. A method for rapid genetic integration into *Plasmodium falciparum* utilizing mycobacteriophage Bxb1 integrase. *Methods Mol Biol* 634:87-100.
16. **Schwank S, Sutherland CJ, Drakeley CJ.** 2010. Promiscuous expression of alpha-tubulin II in maturing male and female *Plasmodium falciparum* gametocytes. *PLoS One* 5:e14470.
17. **Beshir KB, Hallett RL, Eziefula AC, Bailey R, Watson J, Wright SG, Chiodini PL, Polley SD, Sutherland CJ.** 2010. Measuring the efficacy of anti-malarial drugs *in vivo*: quantitative PCR measurement of parasite clearance. *Malar J* 9:312.
18. **van Schalkwyk DA, Burrow R, Henriques G, Gadalla NB, Beshir KB, Hasford C, Wright SG, Ding XC, Chiodini PL, Sutherland CJ.** 2013. Culture-adapted *Plasmodium falciparum* isolates from UK travellers: *in vitro* drug sensitivity, clonality and drug resistance markers. *Malar J* 12:320.
19. **Owen DJ, Collins BM, Evans PR.** 2004. Adaptors for clathrin coats: structure and function. *Annu Rev Cell Dev Biol* 20:153-191.
20. **Boehm M, Bonifacino JS.** 2002. Genetic analyses of adaptin function from yeast to mammals. *Gene* 286:175-186.
21. **Jackson LP, Kelly BT, McCoy AJ, Gaffry T, James LC, Collins BM, Honing S, Evans PR, Owen DJ.** 2010. A large-scale conformational change couples membrane recruitment to cargo binding in the AP2 clathrin adaptor complex. *Cell* 141:1220-1229.
22. **Mita T, Ohashi J, Venkatesan M, Marma AS, Nakamura M, Plowe CV, Tanabe K.** 2014. Ordered accumulation of mutations conferring resistance to sulfadoxine-pyrimethamine in the *Plasmodium falciparum* parasite. *J Infect Dis* 209:130-139.
23. **Eyase FL, Akala HM, Ingasia L, Cheruiyot A, Omondi A, Okudo C, Juma D, Yeda R, Andagalu B, Wanja E, Kamau E, Schnabel D, Bulimo W, Waters NC, Walsh DS, Johnson JD.** 2013. The role of *Pfmdr1* and *Pfcrt* in changing chloroquine, amodiaquine, mefloquine and lumefantrine susceptibility in western-Kenya *P. falciparum* samples during 2008-2011. *PLoS One* 8:e64299.
24. **Rahlfs S, Fischer M, Becker K.** 2001. *Plasmodium falciparum* possesses a classical glutaredoxin and a second, glutaredoxin-like protein with a PICOT homology domain. *J Biol Chem* 276: 37133–37140.
25. **Meshnick, SR.** 2002. Artemisinin: mechanisms of action, resistance and toxicity. *Int J Parasitol* 32(13): 1655-1660.
26. **Olliaro PL, Haynes RK, Meunier B, Yuthavong Y.** 2001. Possible modes of action of the artemisinin-type compounds. *Trends Parasitol* 17(3): 122-126.

# Chapter 8

---

## LOCALIZATION OF ADAPTOR PROTEIN 2 MU-SUBUNIT IN *PLASMODIUM FALCIPARUM* PARASITES

**This chapter will be submitted to the Malaria Journal after further revisions:**  
Henriques G., van Schalkwyk D.A, Burrow R., Baker D.A., Hallett R., Flueck C.,  
Sutherland C.J. Localization of Adaptor Protein 2 mu-subunit in *Plasmodium*  
*falciparum* parasites.



Registry

T: +44(0)20 7299 4646  
F: +44(0)20 7299 4656  
E: registry@lshtm.ac.uk

**COVER SHEET FOR EACH 'RESEARCH PAPER' INCLUDED IN A RESEARCH THESIS**

Please be aware that one cover sheet must be completed for each 'Research Paper' included in a thesis.

**1. For a 'research paper' already published**

1.1. Where was the work published? .....

1.2. When was the work published? .....

1.2.1. If the work was published prior to registration for your research degree, give a brief rationale for its inclusion  
.....  
.....  
.....

1.3. Was the work subject to academic peer review? .....

1.4. Have you retained the copyright for the work? **Yes / No**

If yes, please attach evidence of retention.

If no, or if the work is being included in its published format, please attach evidence of permission from copyright holder (publisher or other author) to include work

**2. For a 'research paper' prepared for publication but not yet published**

2.1. Where is the work intended to be published? *Malaria Journal* .....

2.2. Please list the paper's authors in the intended authorship order

*Henriques G., van Schalkwyk DA, Burrows R, Baker DA, Hallett R, Flueck C, Sutherland C.*

2.3. Stage of publication – Not yet submitted / Submitted / Undergoing revision from peer reviewers' comments / In press

**3. For multi-authored work, give full details of your role in the research included in the paper and in the preparation of the paper. (Attach a further sheet if necessary)**

*I performed the experiments, analyzed the data and drafted the paper.*

NAME IN FULL (Block Capitals) *GISELA CRISTINA LAURENÇO HENRIQUES*

STUDENT ID NO: *298382*

CANDIDATE'S SIGNATURE *Gisela Henriques* Date *27/08/2014*

SUPERVISOR/SENIOR AUTHOR'S SIGNATURE (3 above) *Completed* *27<sup>th</sup> Aug 2014*

## Abstract

*Plasmodium falciparum* is becoming increasingly more resistant to antimalarial drugs, and therefore insights into the mechanisms of drug action and resistance are critical. Recent studies have shown that naturally-occurring mutations in the *P. falciparum mu* subunit of the Adaptor protein 2 complex (AP2) can modulate artemisinin response *in vivo* and functional follow-up revealed that this gene can also modulate *in vitro* parasite sensitivity to multiple drugs. AP2 is part of a family of adaptor proteins that sort cargo into clathrin-coated vesicles for transport between membrane-bound compartments in the cell. By replacing the endogenous *pfap2-mu* gene with green fluorescent protein (GFP)-tagged transgene, we show for the first time that the pfAP2-mu fused with GFP is expressed in trophozoites and schizonts. These transgenic parasites will allow further studies into the molecular mechanisms of clathrin-mediated endocytosis and drug resistance in *P. falciparum* malaria.

## INTRODUCTION

Malaria is one of the most important infectious diseases in humans and remains a major public health and economic problem in developing countries. Antimalarial drugs remain as one of the most powerful tools in the fight against malaria with artemisinin derivatives now standing as the cornerstone of anti-malarial drug therapy. However, recent evidence of reduced susceptibility to artemisinins, manifesting itself by delayed *in vivo* parasite clearance (Noedl, Se *et al.* 2008; Dondorp, Nosten *et al.* 2009), is accumulating on the Thai Cambodian border and nearby countries (Carrara, Lwin *et al.* 2013; Kyaw, Nyunt *et al.* 2013; WHO 2014). It will be a public health disaster if reduced susceptibility to artemisinins spreads to Africa where the burden of disease is high, and where the loss of drug efficacy would unquestionably lead to an increase in morbidity and mortality. Therefore, there is a crucial need to better understand the mechanisms of artemisinin action and the determinants of parasite susceptibility.

Three lines of evidence indicate that components of the clathrin-mediated endocytosis pathway in *Plasmodium* spp. are among the determinants of parasite susceptibility to artemisinins. Firstly, whole genome sequencing in the rodent malaria parasite *Plasmodium chabaudi* led to the identification of a mutation in a gene encoding the *mu* chain of the Adaptor Protein complex 2 (AP2) that arose along with the experimental evolution of *in vivo* artemisinin resistance (Henriques *et al.*, 2013; **Chapter 4**). Secondly, we have recently shown that naturally-occurring mutations in the *P. falciparum* homologue *pfap2-mu* modulate artemisinin response *in vivo* in a cohort of Kenyan children treated with ACT (Henriques *et al.* 2014; **Chapter 5**). Finally, functional studies of transgenic *P. falciparum* carrying an additional copy of the *pfap2-mu* locus revealed that this gene can also modulate *in vitro* parasite sensitivity to multiple drugs (Henriques *et al.*, submitted to AAC; **Chapter 7**).

AP2 is one of a five member family of heterotetrameric clathrin-associated adaptor protein (AP1–5) complexes that mediate transport between membrane-bound compartments in eukaryotic cells by selecting the vesicle cargo and helping in the vesicle biogenesis (Robinson and Bonifacino 2001; Owen, Collins *et al.* 2004; Robinson 2004; Hirst, Barlow *et al.* 2011). Within this family, AP2 is specifically associated with the plasma

membrane and is involved in the internalization of extracellular molecules, cell surface receptors and other plasma membrane proteins (Le Borgne and Hoflack 1998; Traub 2003; Jackson, Kelly *et al.* 2010). Each adaptor protein complex is composed of four subunits: two large (*beta* 1-5, and either *gamma*, *alpha*, *delta*, *epsilon* or *zeta*), one medium (*mu* 1-5) and one small (*sigma* 1-5) (Figure 1). Each of these subunits fulfils a specific function within the complex. The *mu* subunit, in particular, is responsible for cargo selection by directly recognizing the YXX $\phi$  motif (where X is any amino acid and  $\phi$  is a bulky hydrophobic residue), one of the most common sorting signals present in the cytosolic domains of transmembrane proteins (Ohno, Stewart *et al.* 1995; Owen and Evans 1998; Bonifacino and Traub 2003)

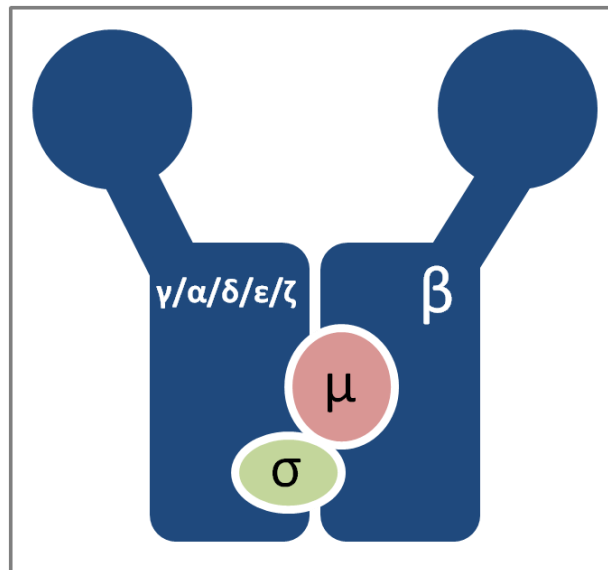

**Figure 1. Schematic representation of the AP complex.** All four complexes consist of two large subunits: a  $\beta$  subunit and a more divergent subunit, either  $\gamma$ ,  $\alpha$ ,  $\delta$ ,  $\epsilon$  or  $\zeta$ ; a medium-sized ( $\mu$ ) subunit; and a small ( $\sigma$ ) subunit. The specific divergent subunits depends on the particular AP complex (AP1:  $\gamma$ ; AP2:  $\alpha$ ; AP3:  $\delta$ ; AP4:  $\epsilon$  and AP5:  $\zeta$ ).

Homologues of all 4 components of the AP2 complex were shown to be present in *P. falciparum* (Nevin and Dacks 2009). In this study we modified the endogenous *pfap2-mu* gene of the Dd2 *P. falciparum* parasite by fusing it to green fluorescence protein (GFP) to study its temporal and spatial expression patterns during the parasite life cycle.



## Material and methods

### Parasite culture and transfection

The Dd2 clone of *Plasmodium falciparum* was cultured in human A<sup>+</sup> erythrocytes (National Health Blood & Transplant, UK) and in complete growth media composed of RPMI 1640 growth medium supplemented with 147 µM hypoxanthine, 5 g/l Albumax II (Invitrogen), 10 mM D-glucose and 2 mM L-glutamine at 2% haematocrit in 5% CO<sub>2</sub> at 37°C.

Parasitaemia was monitored by Giemsa-stained thin blood smears and cultures were synchronized at the ring stage using sequential D-sorbitol lysis treatment (Lambros and Vanderberg, 1979). Where not listed, reagents were obtained from Sigma-Aldrich. For transfections, synchronized ring stage parasites were electroporated with 50 µg of plasmid DNA as described previously (Henriques et al., 2014). Transfected parasites underwent positive selection 24 h after transfection with 5 nM WR99210 (a kind gift from Jacobus Pharmaceuticals, New Jersey, USA) for five weeks with weekly replenishment of fresh red blood cells until resistant parasites were seen. Transformed parasites were selected by repeated drug on-off cycling (3 weeks off and 1 week on) to encourage loss of episomal transformants and selection of parasites in which integration had taken place.

### Molecular cloning, plasmid constructs

A region encoding the 3' end encompassing codons 146 – 621 (leaving out the stop codon) of *pfap2-mu* gene (PlasmoDB identifier: PF3D7\_1218300) was PCR amplified from 3D7 genomic DNA using the forward C1 and reverse C2 primers introducing a 5' *Pst*I and a 3' *Not*I (New England Biolabs) restriction sites, respectively (Table 1). The 1508 bp *pfap2-mu* amplicon was digested with *Pst*I and a *Not*I (New England Biolabs) and cloned into similarly digested pH-GFP transfection plasmid (Witmer, Schmid *et al.* 2012) before GFP coding sequence, to generate pH-*pfap2-mu*-GFP vector (Figure 2A). The transfection vector containing the fusion construct was verified by sequencing, transformed in *E. coli*. Plasmid DNA for transfection was prepared using the Qiagen Maxiprep kit (Quiagen).

### Diagnostic PCR and characterization by Southern blot analysis of Dd2 GFP-transgenic line

Genomic DNA from Dd2::pH-*pfap2-mu*-GFP line and Dd2 (control) was harvested from schizonts at  $\geq 5\%$  parasitaemia. The cells were lysed with saponin and after centrifugation the pellet was resuspended in lysis buffer (500 mM Na Acetate pH 5.2, 100 mM NaCl, 1 mM EDTA, 3% SDS). DNA was isolated with phenol/chloroform extraction at room temperature (RT) and ethanol precipitation. Integration of the GFP-tag construct in the *pfap2-mu* locus was confirmed by a diagnostic PCR using primer pair P1/P2 (Figure 2A; Table 1). The presence of the *pfap2-mu* gene was also confirmed using the P3/P4 primer pairs (Figure 2A; Table 1).

**Table 1.** Primer sequences used in vector integration, PCR confirmation and in probe amplification for Southern blot analysis

Primer	Sequence (5' – 3')	Description
C1	CGT <u>ACTGCAGG</u> ATATCCACAAACATTAGAAG <sup>*</sup>	Amplification of the 3' end of <i>pfap2-mu</i> (Forward)
C2	CGTAG <u>CGGCCGC</u> CATTTATACTGGTAGATGCCCG <sup>**</sup>	Amplification of the 3' end of <i>pfap2-mu</i> (Reverse)
P1	CCGTATTAACAAGAAGCAATTC	Confirming integration of the GFP-tag construct in the <i>pfap2-mu</i> locus (forward)
P2	CCCTCTCCACTGACAGAAAAT	Confirming integration of the GFP-tag construct in the <i>pfap2-mu</i> locus (reverse)
P3	GATATCCACAAACATTAGAAGTG	Confirming the presence of the <i>pfap2-mu</i> (Forward)
P4	CCTTCACACCACCAGATGG	Confirming the presence of the <i>pfap2-mu</i> (Reverse)
S1	CGGGCAACTTCTGATACAAAG	<i>pfap2-mu</i> probe (forward)
S2	GTCCTATTATGTATATGTGGATC	<i>pfap2-mu</i> probe (reverse)

<sup>\*</sup> *Pst*I restriction site is underlined; <sup>\*\*</sup> *Not*I restriction site is underlined.

For Southern blot analysis, genomic DNA was digested with *Cl*aI/*Nco*I (New England Biolabs) and the digested DNA was separated on a 0.8% agarose gel. The gel was depurinated in 0.25 M HCL and denaturated in 0.4 M NaOH before transferred overnight to a BrightStar®-Plus positively charged nylon membrane (Ambicon) by gravitational flow. The DNA was UV cross-linked to the membrane.

The integrants were screened using probes against the 5'-end of the *pfap2-mu* gene. The *pfap2-mu* probe was PCR amplified using the S1/S2 primer pair (Table 1) with the following conditions: 15 sec denaturation at 98°C, 30 sec annealing at 55°C, and elongation 45 min at 68°C; the cycle was repeated 35 times. The PCR product was purified using a QIAquick PCR purification kit (Qiagen).

The probe was <sup>32</sup>P-labelled by random priming using the Redoprime-II random prime labelling system (GE Healthcare). The target DNA was denatured for 5 min at 96°C and cooled on ice for 5 min. Denatured DNA was added to the labelling reaction mix (Klenow fragments, dNTPs, random hexamers), then <sup>32</sup>P dATP (3000 Ci/mM) was added and the mix was incubated for 15 minutes at 37°C and the reaction was stopped using TE buffer. Unincorporated nucleotides were removed using Illustra Microspin G-25 columns (GE Healthcare) and hybridization was performed overnight at 60°C, in a solution containing 6x SCC buffer, 2xDenhardt's, 0.1% SDS, 100 µg/ml of sheared herring DNA. Membranes were washed two times at 60°C, with 2xSSC buffer and exposed to an Amersham Hyperfilm MP (GE Healthcare) at -80°C.

### Fluorescence microscopy

Localization of fluorescent protein-tagged pfAP2-mu in transfected parasites was analyzed through direct detection of the green fluorescence in paraformaldehyde fixed parasite samples and through immunofluorescence assays (IFA). For IFA, thin smears of parasite cultures were air dried and fixed using 100% methanol at -20°C for 2 minutes. The fixed cells were washed with PBS. After washing, the slides were incubated for 1 h at RT with mouse anti-GFP (1:20, Roche) antibody diluted in 3% bovine serum albumin (w/v) in PBS. Cells were washed three times with PBS and incubated with IgG-specific secondary antibody coupled with Alexa Fluor<sup>®</sup> 488 (1:400, Sigma) for 1 h at RT and then washed 3 times with PBS.

The smears were mounted for microscopic examination with vectashield mounting medium with 4',6-diamidini-2-phenylindole (DAPI) (Vector). Images were acquired using a Zeiss LSM510 laser scanning confocal microscope (Carl Zeiss Jena GmbH, Germany) and images were processed using Zeiss LSM Image Browser software version 4.0.0.157.

## Results

To localize pfAP2-mu in the parasite, we have engineered *P. falciparum* Dd2 parasites stably expressing GFP fused to *pfap2-mu* gene under the control of its endogenous promoter, using a single-cross-over homologous recombination strategy (Figure 2A). To ensure authentic and functional expression of this chimaera, the gfp-coding sequence was appended to the 3-end of the endogenous *pfap2-mu* gene. WR99210 resistant parasites were obtained five weeks after transfection and the integration of the GFP-tag construct into the *pfap2-mu* locus was tested for by PCR and Southern blot analysis. Evidence that the plasmid had integrated was provided by the detection of PCR product that amplified the *pfap2-mu*-GFP fusion (expected fragment size: 2000) and the lack of a product for the Dd2 wild-type locus (Figure 2B). Southern blot analysis confirmed the correct integration of the GFP-tag construct into the *pfap2-mu* locus. A 2000 bp product corresponding to the *pfap2-mu*-GFP fusion was detected in schizont genomic DNA isolated from transgenic parasites but not in wild-type Dd2 parasites (Figure 2C). The transfected parasites did not show evidence of any growth defect as compared to the wild type Dd2 parasite (data not shown), indicating that the addition of a C-terminal GFP-tag did not affect asexual multiplication of the parasite *in vitro*.

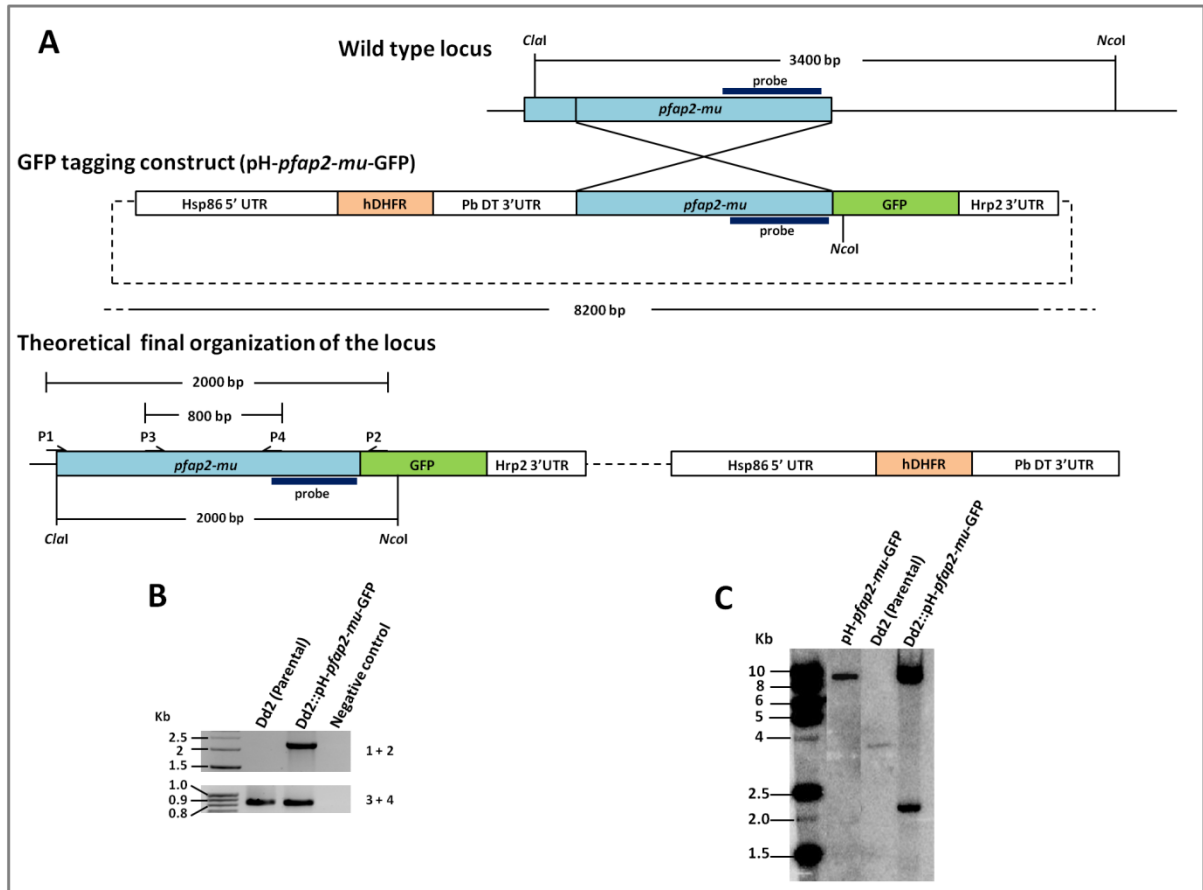

**Figure 2. GFP tagging of *pfap2-mu*.** (A) Schematic representation of the single-cross-over homologous recombination strategy showing the wild type *pfap2-mu* locus (top panel); the pH-*pfap2-mu*-GFP plasmid containing ~1500 bp of the 3' end coding sequence of *pfap2-mu* fused in frame with the GFP sequence (middle panel); and the recombined *pfap2-mu*-GFP locus resulting from integration of the GFP-tag construct (lower panel). Transcription termination and polyadenylation of the *pfap2-mu*-GFP transgene are ensured by the presence of the Hrp2-3' untranslated region (UTR) of *P. falciparum* histidine-rich protein 2. The human dihydrofolate reductase (hDHFR) represents the positive drug selection marker for WR99210. The positions of PCR primers (arrows), the enzyme digestion sites used to detect integration along with the expected fragment sizes and the *pfap2-mu* probe hybridization sites (blue bar) are indicated in the figure. (B) Agarose gel image showing integration of pH-*pfap2-mu*-GFP plasmid by PCR on the transfected parasites. The Dd2 DNA was used as a control. The top panel shows integration of the GFP-tag construct into the *pfap2-mu* locus using the primers P1 and P2 (expected fragment size: 2000 bp). The lower panel shows the presence of the *pfap2-mu* locus, using the P3 and P4 primers (expected fragment size: 800 bp). (C) Confirmation of integration by Southern blot analysis of transfected parasites. Genomic DNA from *P. falciparum* strain Dd2 and transgenic parasites was digested with *Clal* and *NcoI* and separated on a 0.8% agarose gel. Lane 1: Molecular marker; Lane 2: pH-*pfap2-mu*-GFP plasmid; Lane 3: Dd2 (control) and Lane 4: Dd2::pH-*pfap2-mu*-GFP line. The blot was probed with a *pfap2-mu* probe (see panel A). The band expected from a single-site crossover integration of the GFP tag into the 3' end of the *pfap2-mu* gene (expected fragment size: 2000 bp) was observed. The band expected for the digested plasmid (expected fragment size: 8200 bp) was also seen. A single band was observed for the parental strain (expected fragment size: 3400 bp) that was absent in transgenic parasites.

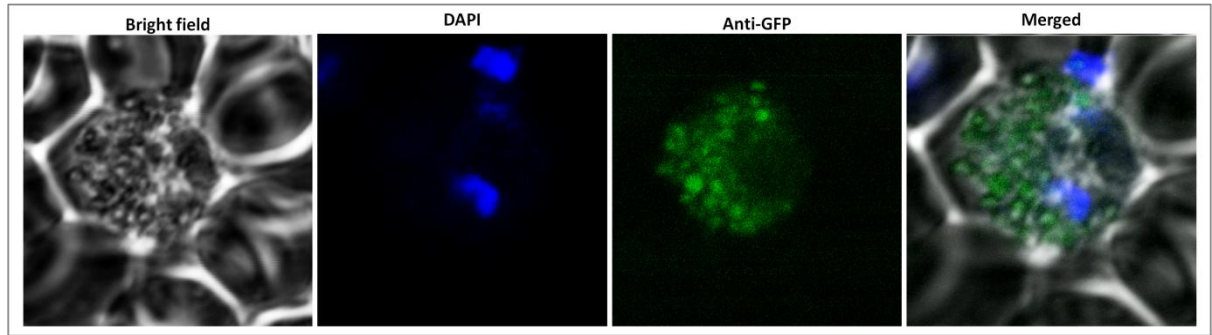
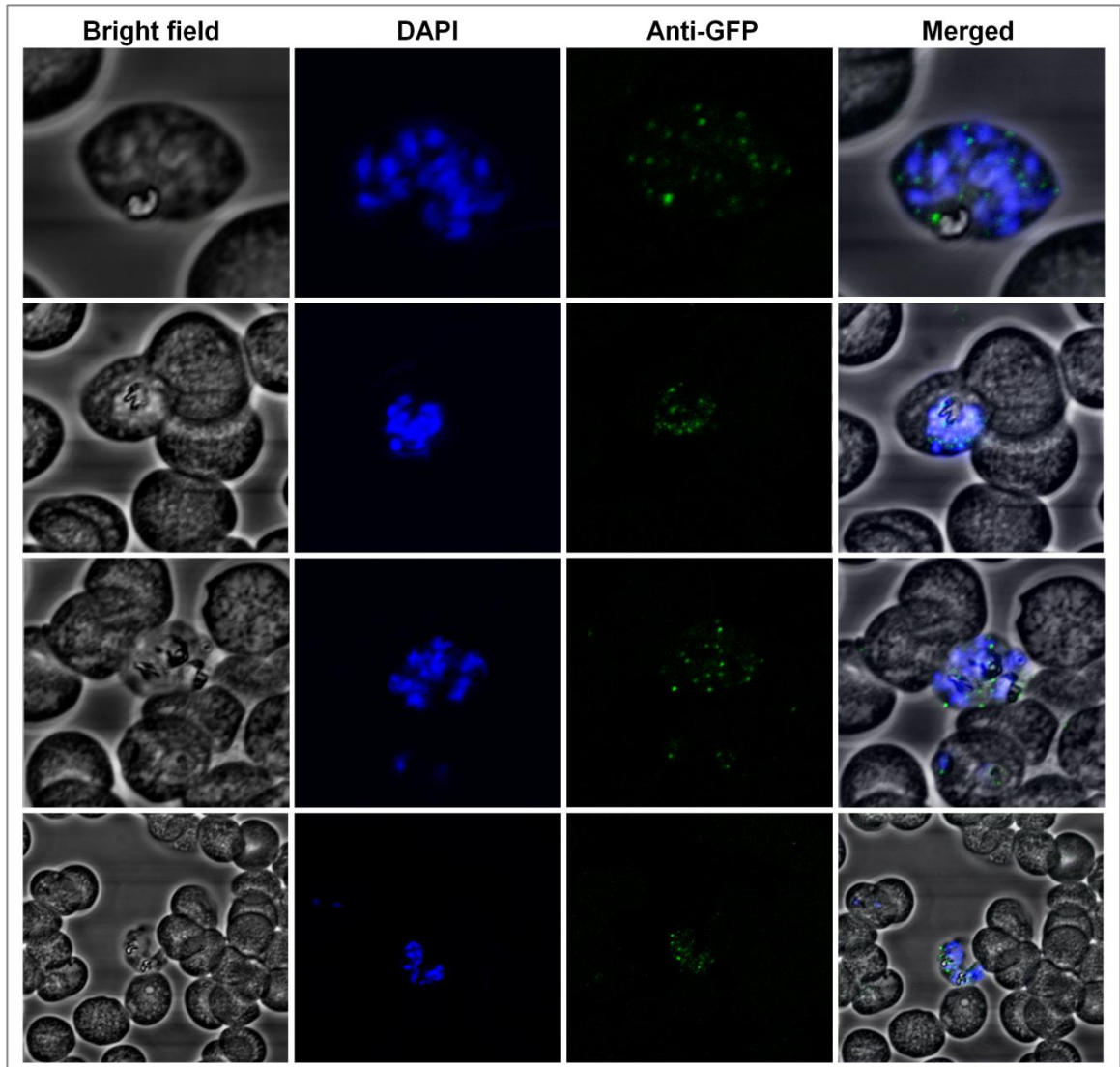

**Figure 3. Localization of pfAP2-mu protein by direct fluorescent microscopy.** The transgenic parasite population was examined by direct fluorescence microscopy to detect GFP (Green). Nuclei were labelled with DAPI stain (blue) prior to analysis. The merged image of the two is also shown together with the corresponding bright field image.

Fluorescence images of fixed *pfap2-mu*-GFP parasites were taken at different intraerythrocytic stages. Although the fusion protein was seen in late trophozoite stage as a weak fluorescence signal (Figure 3), this result was not reproducible. On the other hand, the immunofluorescence microscopic examination of transgenic parasites using an anti-GFP antibody revealed that the *pfap2-mu*-GFP fusion protein was expressed during the schizont state (Figure 4). The AP2-mu-GFP chimeras appeared to localize throughout the cytoplasm in trophozoites (Figures 3 and 4). In schizonts GFP fluorescence was detected at multiple punctuated subcellular structures (Figure 4).

The lack of detectable fluorescence by direct observation can be due to improper folding or instability of the encoded chimeric GFP. Additionally, this result could be attributed to GFP expression having a lesser detection signal than immunocytochemistry using Alexa-conjugated secondary antibodies, which can amplify the signal (Patterson, Knobel *et al.* 1997).

No expression was observed during the ring and trophozoite stages (data not shown). Fluorescent images shown in Figure 4 are representative of *pfAP2-mu*-GFP expression during the schizont stage. Fluorescent signal was visibly concentrated over nucleated (infected) erythrocytes, as indicated by co-localised DAPI fluorescence (Figure 4, fourth column). *P. falciparum* wild type Dd2 parasites were tested as a control for the specificity of GFP localization (Figure 5). In the latter, low density fluorescent signal occurred sporadically in the preparation, but was not associated with nucleated (infected) erythrocytes.



**Figure 4. Confocal microscopy using anti-GFP antibody in the *pfap2-mu*-GFP transgenic line.** Four representative fields (rows) of labelled GFP transgenic parasites, showing the localization of pfAP2-mu-GFP fusion protein in schizonts. The first column of images shows the bright field, the second column DAPI staining of parasite DNA, the third represents GFP fluorescence and the fourth column all images merged. In schizonts, small punctuated subcellular structures of GFP fluorescence were observed.

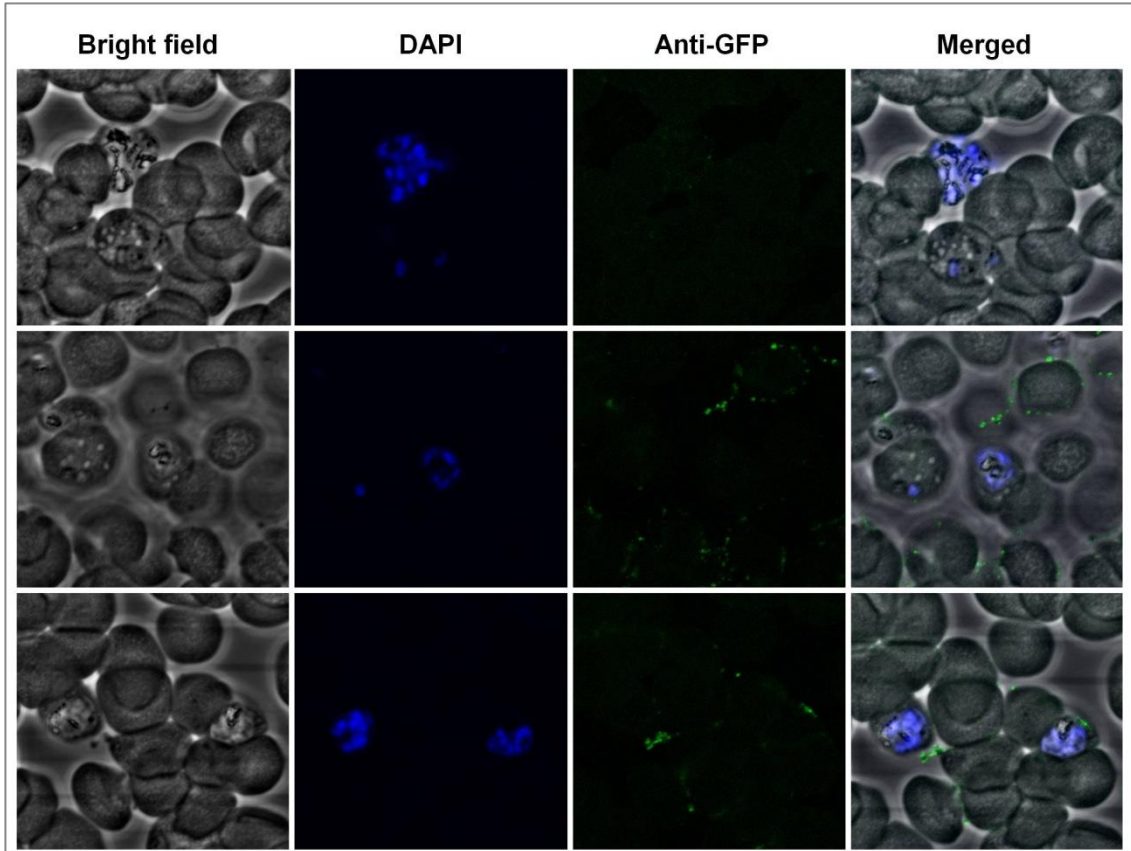

**Figure 5. Confocal microscopy using anti-GFP antibody in *P. falciparum* wild type Dd2 parasites (negative control).** Three representative fields (rows) of labelled Dd2 parasites. The first column of images shows the bright field, the second column DAPI staining of parasite DNA (blue), the third represents GFP fluorescence (green) and the fourth column all images merged. Only faint background fluorescence is visible and is not associated with nucleated (infected) erythrocytes.

## Discussion

We have demonstrated that a GFP-tagged pfAP2-mu can be expressed and detected in the parasite. Expression of the pfAP2-mu-GFP protein was detected in trophozoites by direct observation and in schizonts using an anti-GFP antibody while protein expression was either expressed in undetectable amount or not expressed during ring stage. Additional experiments are necessary in order to determine the stage specific expression and exact localization of the AP2-mu protein in *P. falciparum*. These experiments should include the cloning of *pfap2-mu*-GFP parasites by limiting dilution, in order to obtain a pure parasite population expressing pfAP2-mu-GFP protein as a replacement for the chimeric population used in this study. Future studies will be needed to confirm the expression of



pfap2-mu–GFP fusion protein by western blot and to colocalize pfAP2-mu-GFP protein using different cell compartment markers.

During the blood stage of malaria infection, the parasite internalizes and degrades massive amounts of haemoglobin in the digestive vacuole. One of the processes described for the delivery of haemoglobin into the digestive vacuole was the mechanism mediated by membrane-bound vesicles (clathrin coated vesicles) (Hong-chang *et al.* 2009). These membrane-bound vesicles have specific coat proteins (such as clathrin) that are important for cargo selection and direction of transport between donor and acceptor compartments. Clathrin coats contain both clathrin (acts as a scaffold) and adaptor proteins (AP), that link clathrin to receptors in coated vesicles. AP complexes connect cargo proteins and lipids to clathrin at vesicle budding sites, as well as binding accessory proteins that regulate coat assembly and disassembly (Edeling *et al.* 2006; Owen *et al.* 2004; Robinson *et al.* 2004). Interestingly, the *pfap2-mu* gene encodes a clathrin *mu* adaptor protein that is a subunit of the AP2 adaptor, associated with the plasma membrane and responsible for endocytosis. Consequently, mutations in this protein may alter the adaptor binding specificity affecting the transport of haemoglobin or other proteins by clathrin coated vesicles to the digestive vacuole. The implications of these mutations to artemisinin resistance phenotypes are unclear in the absence of further studies of structure and function of the adaptor complex protein in *Plasmodium* spp.

## Acknowledgments

We thank Priyanka Narang and Sadia Saaed for assistance with confocal microscopy. This work was supported by the Fundação para a Ciência e a Tecnologia (FCT) of Portugal (grant number SFRH/BD/63129/2009).

## References

- Bonifacino, J. S. and L. M. Traub (2003). "Signals for sorting of transmembrane proteins to endosomes and lysosomes." *Annu Rev Biochem* 72: 395-447.
- Carrara, V. I., K. M. Lwin, *et al.* (2013). "Malaria burden and artemisinin resistance in the mobile and migrant population on the Thai-Myanmar border, 1999-2011: an observational study." *PLoS Med* 10(3): e1001398.
- Dondorp, A. M., F. Nosten, *et al.* (2009). "Artemisinin resistance in *Plasmodium falciparum* malaria." *N Engl J Med* 361(5): 455-467.
- Edeling, M.a., Smith, C. & Owen, D. (2006) "Life of a clathrin coat: insights from clathrin and AP structures." *Nature reviews. Molecular cell biology* 7, 32-44.
- Hirst, J., L. D. Barlow, *et al.* (2011). "The fifth adaptor protein complex." *PLoS Biol* 9(10): e1001170.
- Hong-chang, Z. *et al.* (2009). "Dynamin like protein 1 participated in the hemoglobin uptake pathway of *Plasmodium falciparum*." *Chinese Medical Journal* 122, 1686-1691.
- Jackson, L. P., B. T. Kelly, *et al.* (2010). "A large-scale conformational change couples membrane recruitment to cargo binding in the AP2 clathrin adaptor complex." *Cell* 141(7): 1220-1229.
- Kyaw, M. P., M. H. Nyunt, *et al.* (2013). "Reduced susceptibility of *Plasmodium falciparum* to artesunate in southern Myanmar." *PLoS One* 8(3): e57689.
- Lambros, C. and J. P. Vanderberg (1979). "Synchronization of *Plasmodium falciparum* erythrocytic stages in culture." *J Parasitol* 65(3): 418-420.
- Le Borgne, R. and B. Hoflack (1998). "Mechanisms of protein sorting and coat assembly: insights from the clathrin-coated vesicle pathway." *Curr Opin Cell Biol* 10(4): 499-503.
- Nevin, W. D. and J. B. Dacks (2009). "Repeated secondary loss of adaptin complex genes in the Apicomplexa." *Parasitol Int* 58(1): 86-94.
- Noedl, H., Y. Se, *et al.* (2008). "Evidence of artemisinin-resistant malaria in western Cambodia." *N Engl J Med* 359(24): 2619-2620.
- Ohno, H., J. Stewart, *et al.* (1995). "Interaction of tyrosine-based sorting signals with clathrin-associated proteins." *Science* 269(5232): 1872-1875.
- Owen, D. J., B. M. Collins, *et al.* (2004). "Adaptors for clathrin coats: structure and function." *Annu Rev Cell Dev Biol* 20: 153-191.
- Owen, D. J. and P. R. Evans (1998). "A structural explanation for the recognition of tyrosine-based endocytotic signals." *Science* 282(5392): 1327-1332.
- Patterson, G. H., S. M. Knobel, *et al.* (1997). "Use of the green fluorescent protein and its mutants in quantitative fluorescence microscopy." *Biophys J* 73(5): 2782-2790.
- Robinson, M. S. (2004). "Adaptable adaptors for coated vesicles." *Trends Cell Biol* 14(4): 167-174.
- Robinson, M. S. and J. S. Bonifacino (2001). "Adaptor-related proteins." *Curr Opin Cell Biol* 13(4): 444-453.
- Traub, L. M. (2003). "Sorting it out: AP-2 and alternate clathrin adaptors in endocytic cargo selection." *J Cell Biol* 163(2): 203-208.
- WHO (2014). Status report on artemisinin resistance. Geneva, World Health Organization.

Witmer, K., C. D. Schmid, *et al.* (2012). "Analysis of subtelomeric virulence gene families in *Plasmodium falciparum* by comparative transcriptional profiling." *Mol Microbiol* 84(2): 243-259.

# Chapter 9

---

**DISCUSSION**

## Chapter 9 – Discussion

Malaria is a major public health problem which is further exacerbated by *P. falciparum* drug resistance. Over the last few decades the global spread of parasite resistance to almost every frontline antimalarial drug has challenged malaria control programs (WHO 2010a; Petersen *et al.* 2011). To deal with this situation artemisinin based combination therapies have been introduced and widely deployed in malaria endemic regions (Lin *et al.* 2010; WHO 2013f). The characteristic rapid antimalarial action of the artemisinins (White 1997), combined with their extremely short elimination half-lives (Hastings *et al.* 2002; Stepniowska and White 2008) has led to the hope that resistance to artemisinin would never emerge or would be very slow to develop, since parasite exposure to subtherapeutic drug levels is thought to be very brief. Unfortunately, even the artemisinins seem to be losing efficacy in the Greater Mekong subregion (Ashley *et al.* 2014; WHO 2014). In order to preserve the most efficacious drug in controlling malaria infections in SE Asia it is crucial that we understand the underlying mechanisms giving rise to resistance to this class of drugs.

### 9.1. ARTEMISININ RESISTANCE OR TOLERANCE DEBATE

Artemisinin resistance/tolerance remains a controversial issue ever since the discovery of the first suspected cases of resistance. The standard definition of antimalarial resistance includes treatment failure; a parasite is considered resistant if it is able to survive and/or multiply despite the administration of adequate drug dosage and confirmation of adequate antimalarial concentration present in the patient's blood. Artemisinin resistance in the Greater Mekong subregion, characterized by a phenotype of delayed parasite clearance in the first few days after the treatment, does not fulfill this standard definition of resistance. Despite the lengthening of parasite clearance times, artemisinins still cure patients with malaria after the administration of artesunate monotherapy for 7 days (cure rates at day 28 after treatment ranging from 92% to 100%) (Noedl *et al.* 2008; Noedl *et al.* 2010; Bethell *et al.* 2011; Kyaw *et al.* 2013). In any case, any sign of artemisinin decreased effectiveness is alarming. Due to its very high parasite killing rate (White 1997), a delay in the speed at which parasites are cleared after artemisinin treatment can be considered as an early sign

of resistance. Long-lasting infections increase the risk of transmission and as artemisinins become less effective, a higher number of parasites are exposed to the partner drug, thus increasing the probability that parasites resistant to both artemisinin and partner drug will emerge.

Detecting early signs of drug resistance can be very challenging, particularly in the era of ACT treatment. First, the short elimination half-life of artemisinins (Duc *et al.* 1994; de Vries and Dien 1996) can lead to high recrudescence rates after artemisinin monotherapy (Meshnick *et al.* 1996; Giao *et al.* 2001). Second, since artemisinins are used in combination with other drugs a decrease in artemisinin susceptibility will not be directly reflected in a significant increase in clinical failures, which are strongly influenced by resistance to the partner drug. In fact, slower clearance phenotypes are associated with high cure rates after ACT treatment (Dondorp *et al.* 2009; Ashley *et al.* 2014). Resistance to CQ and SP was only recognized after it was already widespread and after treatment failure rates were already very high. Nowadays, we have better monitoring and surveillance methods so we are in a much better position to monitor the emergence of drug resistance in “real time”. For these reasons, we should not wait until artemisinin tolerance reaches the threshold at which artemisinins start to fail and become a clinical problem to try to understand how resistance to this class of drugs may evolve and spread.

The delayed parasite clearance phenotype is now at the core of the current WHO working definition of artemisinin resistance; artemisinin resistance is confirmed if parasites persist for 7 days after treatment with artemisinin monotherapy therapy or the presence of parasites at day 3 followed by recrudescence during follow-up (WHO 2011a). Since news of artemisinin resistance emerged intense investigation in this subject led to the development of improved drug susceptibility assays and to identification of a potential genetic marker of resistance. Standard 48 h *in vitro* tests could not detect *in vivo* slow parasite clearance. New assays, which better simulates *in vivo* drug concentrations revealed the artemisinin tolerance phenotype to be associated with ring stage parasite susceptibility differences (Witkowski *et al.* 2013; Chotivanich *et al.* 2014). Additionally, the clinical slow clearance phenotype has recently been associated with several polymorphisms in the propeller region of a kelch protein (Amaratunga *et al.* 2014; Ariey *et al.* 2014; Ashley *et al.* 2014). These findings will improve the capacity for and utility of molecular and *in vitro* artemisinin resistance surveillance.

Nevertheless, we should not put “all eggs in one basket”. It is crucial that our efforts to quantify and track parasite susceptibility to artemisinins do not neglect the importance of the partner drugs, given that the high failure rates observed after ACT treatment can also be caused due to resistance to the partner drug. In fact, treatment failure rates with artesunate and mefloquine in combination have increased in the Thai-Cambodian border (Vijaykadga *et al.* 2006; Carrara *et al.* 2009; Rogers *et al.* 2009) and this high failure rate can be explained by solely the presence of mefloquine resistance, which was confirmed before the introduction of the artesunate-mefloquine combination therapy (Boudreau *et al.* 1982; Nosten *et al.* 1991). Furthermore, a recent trial conducted in Cambodia reported a high failure rate after dihydroartemisinin-piperaquine treatment suggesting that piperaquine resistance is also emerging (Saunders *et al.* 2014). Moreover, there is also a real risk that resistance can emerge *de novo* elsewhere, as a result of the same or a different set of genetic changes. Proper monitoring of *P. falciparum* susceptibility to both artemisinins and partner drugs across the entire malaria endemic world is imperative, but particularly in sub-Saharan Africa, since the emergence of resistance there should it occur, would undoubtedly lead to increased morbidity and mortality.

In this context, the main aims of this thesis were to identify and characterize the genetic determinants responsible for the artemisinin resistant phenotype observed in a lineage of *P. chabaudi* drug-pressured parasites. Initially, we identified a unique mutation in a gene encoding the mu-chain of the AP2-adaptor complex in a *P. chabaudi* parasite displaying high level of artemisinin resistance. Afterwards we investigated the importance of this and two other molecular markers identified in the rodent model, in modulating susceptibility to artemisinins in *P. falciparum* natural populations.

## 9.2. ARTEMISININ RESISTANCE PHENOTYPE IN RODENT MALARIA

In **Chapter 4** we have characterized a parasite resistant to artemisinin derived from a CQ resistant parasite after prolonged and progressive artemisinin selection (Afonso *et al.* 2006b). Using whole-genome sequencing we identified one point mutation in a gene encoding an AP2 adaptor protein, a component of the endocytic machinery. AP2-mu 3D structure homology models indicate that the mutated residue interacts with a cargo recognition sequence, suggesting that the endocytosis and trafficking of membrane

proteins is modified in artemisinin resistant rodent malaria parasite. This provides new insights into possible mechanisms of resistance to artemisinin and its derivatives.

### 9.3. CORRELATION OF *IN VITRO* PARASITE SUSCEPTIBILITY AND POLYMORPHISMS IN CANDIDATE MOLECULAR MARKERS

The DNA sequence analysis of *pfap2-mu* gene in Brazil, São Tomé and Rwanda isolates revealed a total of 12 polymorphic sites, consisting of five non-synonymous and 4 synonymous mutations and three insertions. A polymorphism similar to *P. chabaudi* I568T was not detected in any of the *P. falciparum* isolates. One non-synonymous mutation (160N) was weakly correlated with *in vitro* responses to dihydroartemisinin in isolates from Rwanda (**Chapter 4**).

Association between the IC<sub>50</sub> to QN, CQ, MDA, LUM, PIP and DHA and *P. falciparum* polymorphisms in *pfubp1*, *pfap2-mu* and *pf26S-protSU* was assessed in isolates obtained from a clinical trial of AL and AS + AQ in Burkina Faso. Data revealed that polymorphisms in *pfubp1* and *pf26S-protSU*, can modulate *in vitro* responses to Lumefantrine. Additionally, this study is in agreement with the recent suggestion that polymorphisms in *pfap2-mu* may contribute to *P. falciparum* susceptibility to multiple drugs. Further studies are necessary to further confirm the importance of these new molecular markers in modulating *P. falciparum* antimalarial drug susceptibility.

### 9.4. CORRELATION OF *IN VIVO* PARASITE SUSCEPTIBILITY AND POLYMORPHISMS IN THE CANDIDATE MOLECULAR MARKERS

In **Chapter 5** we genetically characterized the recently described Kenyan sub-microscopic persistent parasites. These parasites were significantly more likely to carry mutant alleles of the *pfap2-mu* and *pfubp1* genes than the baseline population suggesting that the sub-microscopic persistency phenotype is genetically determined. These sub-microscopic parasites were also associated with a higher transmission potential and with an elevated risk of recurrent infections (Beshir *et al.* 2013). Taken together, these results point towards the necessity for further research on the public health impact of these sub-microscopic parasites and the role of these loci as *in vivo* markers of parasite survival after ACT treatment.



### 9.5. FUNCTIONAL ANALYSIS OF THE *PFAP2-MU* GENE

In order to further evaluate the role of *pfap2-mu* gene in artemisinin susceptibility modulation and improve our understanding of the underlying biological mechanisms we functionally characterized this gene using transfection techniques (Chapters 7 and 8). The transgenic parasites carrying the 160Asn allele of *pfap2-mu* were significantly less sensitive to DHA, QN and CQ suggesting a general mechanism which modulates the drug response to different antimalarial drugs (Chapter 7). This broad mechanism can directly contribute for the emergence of artemisinin resistance but also indirectly, by sequentially decreasing the efficacy of the partner drugs, exposing the artemisinin component to selective pressure. This selective pressure could subsequently facilitate emergence of new foci of tolerance to artemisinins. Further experiments are needed to investigate the role of pfAP2-mu in modulating parasite susceptibility to other ACT partner drugs not evaluated in this study, namely amodiaquine, piperaquine and pyronaridine.

We have generated a parasite stably expressing a GFP-fused *pfap2-mu* and we showed, for the first time, that the pfAP2-mu fused with GFP is expressed in trophozoites and schizonts stages (Chapter 8). These transgenic parasites will allow further studies into the molecular mechanisms of clathrin-mediated endocytosis and drug resistance in *P. falciparum* malaria.

### 9.6. SE ASIA PHENOTYPE VS AFRICAN PHENOTYPE

ACT efficacy in Africa remains high (Ashley *et al.* 2014; Zani *et al.* 2014) and until now, there are no signs of resistance in this continent. However, we recently reported persistency of sub-microscopic *P. falciparum* parasites until day 3 after ACT treatment in Kenyan children. Children carrying such parasites were significantly more likely to be infectious to mosquitoes and experience late treatment failure (Beshir *et al.* 2013). Interestingly, these persistent sub-microscopic parasites carry a specific genetic signature including the wild type CVMNK *pfcr*t haplotype, the NFD *pfmdr*1 haplotype and the 160N/T *pfap2-mu* and 1528D *pfubp*1 mutations (Henriques *et al.* 2014a). It is important to note that this phenotype appears to be significantly different from the slow clearance of

*P. falciparum* infections reported in Southeast Asia. Firstly, by microscopy all infections were cleared before day 3 after the ACT treatment. Secondly, the Southeast Asian isolates have a different genetic signature, as they are known to carry the K76T *pfCRT* mutation, and *pfmdr1* polymorphisms are not associated with reduced artemisinin susceptibility (Imwong *et al.* 2010). As far as we know, slow clearing Cambodian isolates do not carry the 160N/T *pfap2-mu* polymorphisms (Henriques *et al.* 2014a), but this requires confirmation. On the contrary, slow parasite clearance of Southeast Asian parasites has recently been linked with point mutations in the *pfk13* kelch propeller domain. We are currently evaluating this gene in *P. falciparum* isolates from eastern Kenya. Functional analysis of *pfap2-mu* *in vitro* revealed that transgenic parasites constitutively expressing the 160Asn mutant form of *pfap2-mu* were significantly less sensitive to dihydroartemisinin using a standard 48 hour drug assay, but did not demonstrate increased survival in the ring stage parasite survival assay (Henriques *et al.*, submitted; Chapter 7). Taken together, these findings suggest that modulation of artemisinin sensitivity in an African context clearly manifests as a different phenotype from the one described in Cambodia with different genes and multi-locus genotypes implicated. In fact, some African slowly clearing infections described recently are not associated with polymorphisms in the kelch protein, suggesting the contribution of other genetic factors (Ashley *et al.* 2014).

Our interpretation is that polymorphisms in *pfap2-mu* may not confer resistance *per se* but they could be in some way advantageous for the parasites, enhancing their likelihood of survival. This fitness enhancement could be explained by a gain in biological robustness. Biological robustness is a major evolutionary mechanism that allows mutations to accumulate in the organism background while maintaining a little changed-changed functional phenotype. The role of this mechanism during the acquisition of pyrimethamine resistance in *P. falciparum* was recently described. Amplification of the GTP cyclohydrolase I increased the robustness of the folate pathway allowing the fixation of subsequent mutations in DHFR that could be deleterious/disadvantageous in the absence of GTP cyclohydrolase I amplification (Kumpornsin *et al.* 2014). In a similar way, *pfap2-mu* polymorphisms can increase the robustness of the parasites by reducing the fitness cost associated with the acquisition of mutations in other genes directly involved in artemisinin resistance.

Alternatively, AP2-mu could be directly involved in the mechanism of artemisinin resistance. Drug resistance may not arise in a single step, but as a long and complex process

during which parasites become gradually more and more tolerant to the drug. This is believed to be achieved through the stepwise accumulation of genetic changes in the same gene or in different genes (Mita *et al.* 2014). Therefore, it is possible that mutations in AP2-mu are an early step during the development of artemisinin resistance, and that additional genetic changes would be required before a fully resistant parasite genotype is able to emerge.

### 9.7. POSSIBLE MODEL OF ARTEMISININ RESISTANCE MEDIATED BY UBIQUITIN-DEPENDENT ENDOCYTOSIS VIA CLATHRIN-COATED VESICLES

Transmembrane proteins are a diverse group of proteins containing receptors, ion channels, transporters, anchors and pumps that are responsible for a variety of key cellular mechanisms. The availability and localization of these proteins is dynamically regulated by endocytosis. Transmembrane proteins destined for internalization are packaged into a vesicle, which is invaginated due to the action of various accessory adaptor proteins and clathrin (Kelly and Owen 2011). The AP-2 adaptor complex interacts with the internalization signal of the cargo protein and starts recruiting clathrin and other accessory proteins involved in the clathrin mediated endocytosis (Bonifacino and Traub 2003). After endocytosis, proteins enter the early endosome where they are sorted, and are either recycled back to the plasma membrane or targeted for destruction (Le Roy and Wrana 2005).

Here we suggest a speculative model (Figure 9.1) for the involvement of AP2-mu, UBP1 and 26SPS in artemisinin resistance based on the ubiquitin-dependent endocytosis via clathrin-coated vesicles. Artemisinin resistance could conceivably have its foundation on one or a combination of the following molecular interactions:

#### 1 – Regulation of membrane protein abundance

Several studies have shown that ubiquitination acts as a signal for internalization and sorting of certain membrane proteins (Kolling and Hollenberg 1994; Hicke 2001; Hicke and Dunn 2003). Together, ubiquitin and deubiquitinating enzymes provide a reversible modification that regulates the fate of target proteins (Bonifacino and Weissman 1998). Ubiquitination is a process by which ubiquitin monomers form covalent bonds with

the target protein. Deubiquitinating enzymes play the antagonistic role, by removing the ubiquitin monomers from target substrates (Nijman *et al.* 2005). A poly-ubiquitin chain of at least four ubiquitin molecules can trigger degradation of the substrate by the 26S proteasome into peptides and free ubiquitin (Hicke and Dunn 2003; Komander and Rape 2012). On the contrary, proteins modified by a single ubiquitin may escape proteasomal recognition and be recycled back to the plasma membrane through sorting and recycling endosomes (Hegde and DiAntonio 2002; Dupre *et al.* 2004).

Modifications in AP2-mu (mu subunit of clathrin associated adaptor protein 2), UBP1 (deubiquitinase enzyme) and 26S-protSU (subunit of the 26S proteasome) proteins may modulate artemisinin resistance by controlling the abundance of important membrane proteins, like MDR1, for example. Interestingly, it has been shown that a member of the ABC family of transporters accumulates in the plasma membrane of yeast mutants with a defective endocytosis pathway or ubiquitination-deficiencies (Kolling and Hollenberg 1994). Furthermore, changes in the clathrin-dependent endocytosis and trafficking of *mdr1*-encoded P-glycoprotein (in human cancer cell lines) alter both its partition between cell membrane and intracellular pools, as well as drug resistance levels (Kim *et al.* 1997). Finally, P-glycoprotein distributions within cancer cells and their respective drug-resistance phenotypes are also mediated by ubiquitination (Zhang *et al.* 2004). Therefore, it is possible that mutations on the three candidate markers increase the half-life of MDR1 by preventing its degradation by the proteasome.

## **2 - Regulation of stress responses**

The ubiquitin-proteasome pathway plays a critical role in stress response by degrading misfolded or damaged proteins, which would otherwise accumulate and harm the cell (Dantuma and Lindsten 2010; Shang and Taylor 2011). Artemisinin action has been linked to the generation of radicals, which damage the parasite (Meshnick *et al.* 1993; Meshnick 1994a). Modifications on the ubiquitin-proteasome pathway could conceivably increase the probability of parasite survival despite the putative oxidative stress generated by artemisinin action.

### 3 – Dormancy

Resistance to artemisinins has been related to general biological features like dormancy (Cheng *et al.* 2012; Teuscher *et al.* 2012). The parasite can enter a state of reversible quiescence by perhaps activating the autophagy-dependent survival mechanism, which allows the parasite to recycle both nutrients and energy during dormancy. Interestingly it was recently described that the autophagy-mediated degradation can be regulated by the ubiquitin-proteasome pathway (Korolchuk *et al.* 2010; Klionsky and Schulman 2014).

Experimental studies on the molecular interactions between the ubiquitin-proteasome system, and clathrin-mediated endocytosis may provide important insights regarding artemisinin action and resistance mechanisms.

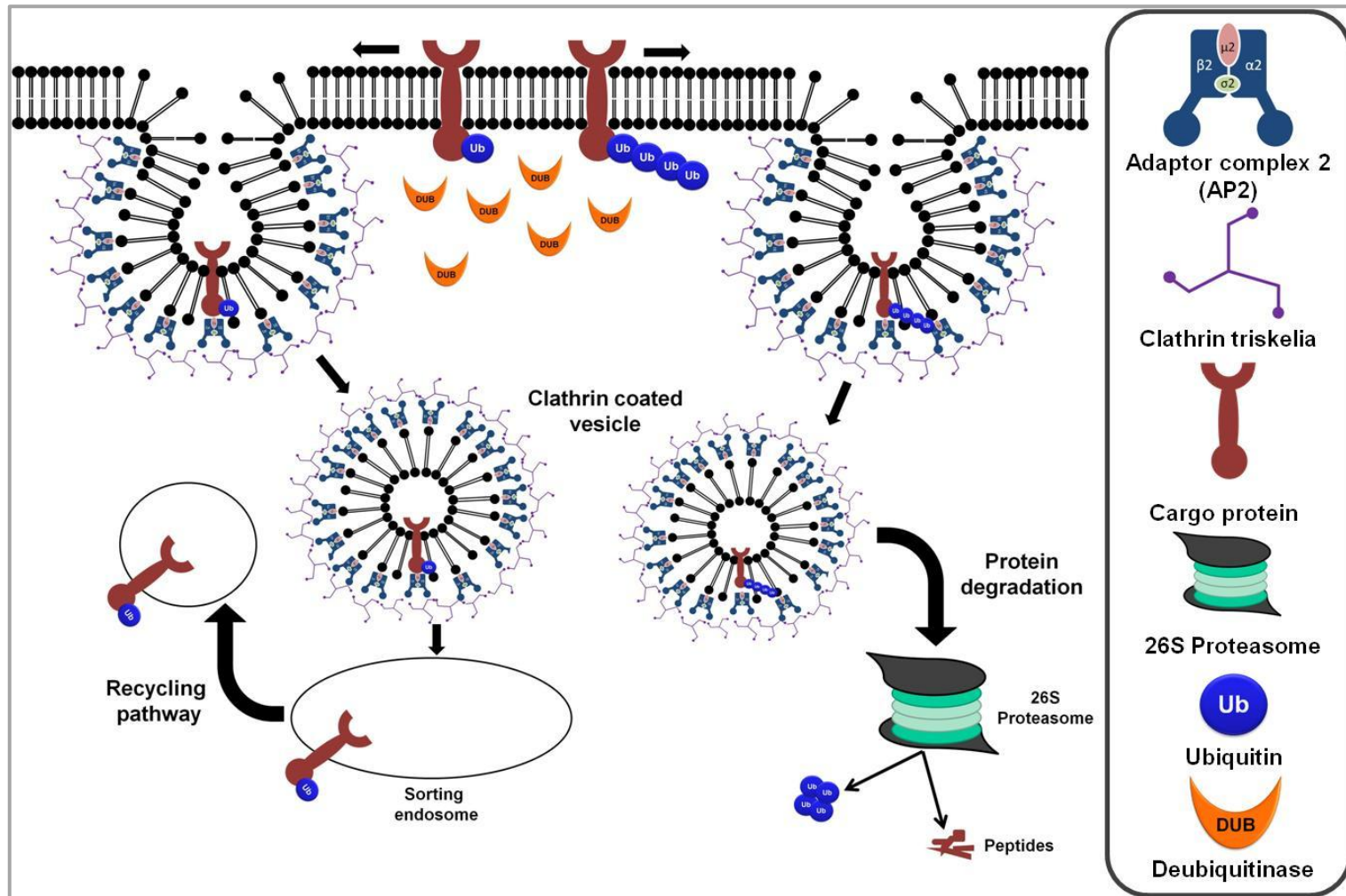

**Figure 9.1** – Possible model for the involvement of AP2-mu, UBP1 and 26SPS in artemisinin resistance based on the ubiquitin-dependent endocytosis via clathrin-coated vesicles

# Chapter **10**

---

**FUTURE PERSPECTIVES**

## Chapter 10 – Future Perspectives

Pharmaceutical research has not kept up with the growing resistance to antimalarials. *P. falciparum* develops resistance much faster than the rate of new pharmaceuticals is being developed and a loss of the artemisinins to resistance would have disastrous consequences for malaria control. Although it may not be possible to prevent the emergence and/or spread of artemisinin resistant parasites, understanding their mechanisms of action and resistance can provide crucial information to maximise the life expectancy of this important class of antimalarial drugs.

The main hypothesis of this thesis, that the three loci that mediate ART resistance in experimentally selected in *P. chabaudi* will similarly modify ART response in natural parasite populations of *P. falciparum*, was partially supported by two of the three genes investigated, *pfubp1* and *pfap2-mu*. Nevertheless, there are some gaps in evidence that should be addressed in future studies:

- Directional selection of *pfubp1* and *pf26S-protSU* polymorphisms should be investigated on day 3 after ACT treatments, and not only on day fail;
- It will be important to compare in vitro susceptibility of the transgenic parasites to that of Cambodian parasite lines with known clearance time phenotypes;
- Further work should include gene replacement experiments and explore the impact of *pfap2-mu* mutations in a chloroquine sensitive background

This thesis has shed light on the complex issue of *P. falciparum* resistance to artemisinins and will foster new studies to understand its mechanisms. It also confirmed the feasibility of coupling the *P. chabaudi* model to validation in the *P. falciparum* parasite *in vivo* and *in vitro* for identifying novel drug resistance loci.

Another weakness of our study was that some isolates of interest were not sequenced at all loci, mainly due to exhaustion of small, finite blood samples. Although the limited number of observations in each of the treatment arms precluded comparisons of effect estimates due to lack of power, an exploratory stratification was carried out, generating odds ratios with very wide confidence intervals (data not shown)



Further studies are needed to determine the public health impact of the newly observed phenomenon of persisting sub-microscopic parasites and their relation with particular mutations in the *pfap2-mu* and *pfubp1* genes. To achieve this we intend to analyse samples from a recent ACT clinical trial (ClinicalTrials.gov identifier: NCT01939886) conducted in 2013 in Mbita, Kenya, the same location where the first clinical trial was conducted, 4 years earlier (Beshir *et al.* 2013; Sawa *et al.* 2013; Henriques *et al.* 2014a).

We also plan to extend the functional studies of *P. falciparum* *pfap2-mu* polymorphisms, using Zinc-Finger Nuclease (ZFN)-mediated gene editing, a new technology that allows the production of mutant parasites with much higher efficiency and reduced timelines. We intend to generate transgenic lines harbouring the *P. falciparum* 160Asn mutation and the *P. chabaudi* 592Thr resistant mutation using both laboratory adapted strains and one Kenyan clinical isolate (HL1204), recently adapted to *in vitro* culture (van Schalkwyk *et al.* 2013). Parasite clones expressing the variant alleles will then be tested for their susceptibility to a panel of antimalarial drugs including artemisinin derivatives and their partner drugs. An alternative approach for gene editing is the use of clustered, regularly interspaced, short palindromic repeat (CRISPR) technology. This new strategy takes advantage of a short RNA to guide the Cas9 endonuclease to cause a double strand breaks at any specific genomic loci and has been recently adapted in *P. falciparum* (Ghorbal *et al.* 2014).

These allelic replacement studies would significantly improve our understanding on how polymorphisms in AP2-mu can modify ART sensitivity in isolates with different backgrounds, including chloroquine-sensitive genotypes.

# Chapter 11

---

REFERENCES

## Chapter 11 - References

- Adjalley, S. H., M. C. Lee, *et al.* (2010). "A method for rapid genetic integration into *Plasmodium falciparum* utilizing mycobacteriophage Bxb1 integrase." Methods Mol Biol **634**: 87-100.
- Afonso, A., P. Hunt, *et al.* (2006a). "Malaria Parasites Can Develop Stable Resistance to Artemisinin but Lack Mutations in Candidate Genes *atp6* (Encoding the Sarcoplasmic and Endoplasmic Reticulum Ca<sup>2+</sup> ATPase), *tctp*, *mdr1*, and *cg10*." Antimicrobial Agents and Chemotherapy **50**(2): 480-489.
- Afonso, A., P. Hunt, *et al.* (2006b). "Malaria parasites can develop stable resistance to artemisinin but lack mutations in candidate genes *atp6* (encoding the sarcoplasmic and endoplasmic reticulum Ca<sup>2+</sup> ATPase), *tctp*, *mdr1*, and *cg10*." Antimicrob Agents Chemother **50**(2): 480-489.
- Agnandji, S. T., B. Lell, *et al.* (2012). "A phase 3 trial of RTS,S/AS01 malaria vaccine in African infants." N Engl J Med **367**(24): 2284-2295.
- Agnandji, S. T., B. Lell, *et al.* (2011). "First results of phase 3 trial of RTS,S/AS01 malaria vaccine in African children." N Engl J Med **365**(20): 1863-1875.
- Amaratunga, C., B. Witkowski, *et al.* (2014). "Plasmodium falciparum Founder Populations in Western Cambodia Have Reduced Artemisinin Sensitivity In Vitro." Antimicrob Agents Chemother **58**(8): 4935-4937.
- Anderson, T. J. and C. Roper (2005). "The origins and spread of antimalarial drug resistance: lessons for policy makers." Acta Trop **94**(3): 269-280.
- Ariey, F., B. Witkowski, *et al.* (2014). "A molecular marker of artemisinin-resistant *Plasmodium falciparum* malaria." Nature **505**(7481): 50-55.
- Ashley, E. A., M. Dhorda, *et al.* (2014). "Spread of artemisinin resistance in *Plasmodium falciparum* malaria." N Engl J Med **371**(5): 411-423.
- Ashley, E. A., K. Stepniewska, *et al.* (2007). "Pharmacokinetic study of artemether-lumefantrine given once daily for the treatment of uncomplicated multidrug-resistant falciparum malaria." Trop Med Int Health **12**(2): 201-208.
- Auparakkitanon, S., S. Chapoomram, *et al.* (2006). "Targeting of hematin by the antimalarial pyronaridine." Antimicrob Agents Chemother **50**(6): 2197-2200.
- Avery, M. A., F. Gao, *et al.* (1993). "Structure-activity relationships of the antimalarial agent artemisinin. 1. Synthesis and comparative molecular field analysis of C-9 analogs of artemisinin and 10-deoxoartemisinin." J Med Chem **36**(26): 4264-4275.
- Baggish, A. L. and D. R. Hill (2002). "Antiparasitic agent atovaquone." Antimicrob Agents Chemother **46**(5): 1163-1173.
- Baird, J. K. and S. L. Hoffman (2004). "Primaquine therapy for malaria." Clin Infect Dis **39**(9): 1336-1345.
- Barnes, K. I. and N. J. White (2005). "Population biology and antimalarial resistance: The transmission of antimalarial drug resistance in *Plasmodium falciparum*." Acta Tropica **94**(3): 230-240.
- Barradell, L. B. and A. Fitton (1995). "Artesunate. A review of its pharmacology and therapeutic efficacy in the treatment of malaria." Drugs **50**(4): 714-741.
- Basco, L. K., J. Bickii, *et al.* (1998). "In vitro activity of lumefantrine (benflumetol) against clinical isolates of *Plasmodium falciparum* in Yaounde, Cameroon." Antimicrob Agents Chemother **42**(9): 2347-2351.
- Basco, L. K. and J. Le Bras (1992). "In vitro activity of pyronaridine against African strains of *Plasmodium falciparum*." Ann Trop Med Parasitol **86**(5): 447-454.

- Basco, L. K. and P. Ringwald (2000). "Molecular epidemiology of malaria in Yaounde, Cameroon. VI. Sequence variations in the Plasmodium falciparum dihydrofolate reductase-thymidylate synthase gene and in vitro resistance to pyrimethamine and cycloguanil." *Am J Trop Med Hyg* **62**(2): 271-276.
- Basco, L. K., R. Tahar, *et al.* (1998). "Molecular basis of in vivo resistance to sulfadoxine-pyrimethamine in African adult patients infected with Plasmodium falciparum malaria parasites." *Antimicrob Agents Chemother* **42**(7): 1811-1814.
- Bentley, D. R. (2006). "Whole-genome re-sequencing." *Curr Opin Genet Dev* **16**(6): 545-552.
- Beshir, K., C. J. Sutherland, *et al.* (2010). "Amodiaquine resistance in Plasmodium falciparum malaria in Afghanistan is associated with the pfcr1 SVMNT allele at codons 72 to 76." *Antimicrob Agents Chemother* **54**(9): 3714-3716.
- Beshir, K. B., R. L. Hallett, *et al.* (2010). "Measuring the efficacy of anti-malarial drugs in vivo: quantitative PCR measurement of parasite clearance." *Malar J* **9**: 312.
- Beshir, K. B., C. J. Sutherland, *et al.* (2013). "Residual Plasmodium falciparum parasitemia in Kenyan children after artemisinin-combination therapy is associated with increased transmission to mosquitoes and parasite recurrence." *J Infect Dis* **208**(12): 2017-2024.
- Bethell, D., Y. Se, *et al.* (2011). "Artesunate dose escalation for the treatment of uncomplicated malaria in a region of reported artemisinin resistance: a randomized clinical trial." *PLoS One* **6**(5): e19283.
- Bhisutthibhan, J. and S. R. Meshnick (2001). "Immunoprecipitation of [(3)H]dihydroartemisinin translationally controlled tumor protein (TCTP) adducts from Plasmodium falciparum-infected erythrocytes by using anti-TCTP antibodies." *Antimicrob Agents Chemother* **45**(8): 2397-2399.
- Biagini, G. A., P. Viriyavejakul, *et al.* (2006). "Functional characterization and target validation of alternative complex I of Plasmodium falciparum mitochondria." *Antimicrob Agents Chemother* **50**(5): 1841-1851.
- Biamonte, M. A., J. Wanner, *et al.* (2013). "Recent advances in malaria drug discovery." *Bioorg Med Chem Lett* **23**(10): 2829-2843.
- Bloland, P. B. (2003). "Trends in antimalarial drug deployment in sub-Saharan Africa." *Journal of Experimental Biology* **206**(21): 3761-3769.
- Bloland, P. B., M. Ettling, *et al.* (2000). "Combination therapy for malaria in Africa: hype or hope?" *Bull World Health Organ* **78**(12): 1378-1388.
- Bonifacino, J. S. and L. M. Traub (2003). "Signals for sorting of transmembrane proteins to endosomes and lysosomes." *Annu Rev Biochem* **72**: 395-447.
- Bonifacino, J. S. and A. M. Weissman (1998). "Ubiquitin and the control of protein fate in the secretory and endocytic pathways." *Annu Rev Cell Dev Biol* **14**: 19-57.
- Borges, S., P. Cravo, *et al.* (2011). "Genomewide scan reveals amplification of mdr1 as a common denominator of resistance to mefloquine, lumefantrine, and artemisinin in Plasmodium chabaudi malaria parasites." *Antimicrob Agents Chemother* **55**(10): 4858-4865.
- Borrmann, S., P. Sasi, *et al.* (2011). "Declining responsiveness of Plasmodium falciparum infections to artemisinin-based combination treatments on the Kenyan coast." *PLoS One* **6**(11): e26005.
- Boudreau, E. F., H. K. Webster, *et al.* (1982). "Type II mefloquine resistance in Thailand." *Lancet* **2**(8311): 1335.
- Bray, P. G., R. E. Martin, *et al.* (2005). "Defining the role of PfCRT in Plasmodium falciparum chloroquine resistance." *Mol Microbiol* **56**(2): 323-333.
- Bray, P. G., M. Mungthin, *et al.* (2006). "PfCRT and the trans-vacuolar proton electrochemical gradient: regulating the access of chloroquine to ferroprotoporphyrin IX." *Mol Microbiol* **62**(1): 238-251.

- Bray, P. G., S. A. Ward, *et al.* (2005). "Quinolines and artemisinin: chemistry, biology and history." *Curr Top Microbiol Immunol* **295**: 3-38.
- Breman, J. G., M. S. Alilio, *et al.* (2004). "Conquering the intolerable burden of malaria: what's new, what's needed: a summary." *Am J Trop Med Hyg* **71**(2 Suppl): 1-15.
- Briolant, S., L. Almeras, *et al.* (2010). "Plasmodium falciparum proteome changes in response to doxycycline treatment." *Malar J* **9**: 141.
- Briolant, S., M. Baragatti, *et al.* (2009). "Multinormal in vitro distribution model suitable for the distribution of Plasmodium falciparum chemosusceptibility to doxycycline." *Antimicrob Agents Chemother* **53**(2): 688-695.
- Brooks, D. R., P. Wang, *et al.* (1994). "Sequence variation of the hydroxymethyldihydropterin pyrophosphokinase: dihydropteroate synthase gene in lines of the human malaria parasite, Plasmodium falciparum, with differing resistance to sulfadoxine." *Eur J Biochem* **224**(2): 397-405.
- Bruce-Chwatt, L. J. (1986). *Chemotherapy of malaria*. Geneva, World Health Organization.
- Campbell, C. C., W. Chin, *et al.* (1979). "Chloroquine-resistant Plasmodium falciparum from East Africa: cultivation and drug sensitivity of the Tanzanian I/CDC strain from an American tourist." *Lancet* **2**(8153): 1151-1154.
- Caramello, P., F. Canta, *et al.* (2005). "Chemosusceptibility analysis of Plasmodium falciparum imported malaria in Italy." *Diagn Microbiol Infect Dis* **52**(2): 107-112.
- Carlton, J., M. Mackinnon, *et al.* (1998). "A chloroquine resistance locus in the rodent malaria parasite Plasmodium chabaudi." *Mol Biochem Parasitol* **93**(1): 57-72.
- Carlton, J. M., K. Hayton, *et al.* (2001). "Of mice and malaria mutants: unravelling the genetics of drug resistance using rodent malaria models." *Trends Parasitol* **17**(5): 236-242.
- Carrara, V. I., J. Zwang, *et al.* (2009). "Changes in the treatment responses to artesunate-mefloquine on the northwestern border of Thailand during 13 years of continuous deployment." *PLoS One* **4**(2): e4551.
- Carter, R. and C. L. Diggs (1977). *Plasmodia of rodents*. New York/San Francisco/London, Academic.
- Carter, R. and D. Walliker (1975). "New observations on the malaria parasites of rodents of the Central African Republic - Plasmodium vinckei petteri subsp. nov. and Plasmodium chabaudi Landau, 1965." *Ann Trop Med Parasitol* **69**(2): 187-196.
- Chaijaroenkul, W., R. Wisedpanichkij, *et al.* (2010). "Monitoring of in vitro susceptibilities and molecular markers of resistance of Plasmodium falciparum isolates from Thai-Myanmar border to chloroquine, quinine, mefloquine and artesunate." *Acta Trop* **113**(2): 190-194.
- Chang, C., T. Lin-Hua, *et al.* (1992). "Studies on a new antimalarial compound: pyronaridine." *Trans R Soc Trop Med Hyg* **86**(1): 7-10.
- Chavalitsheinkoon, P., P. Wilairat, *et al.* (1993). "Structure-activity relationships and modes of action of 9-anilinoacridines against chloroquine-resistant Plasmodium falciparum in vitro." *Antimicrob Agents Chemother* **37**(3): 403-406.
- Cheeseman, I. H., B. A. Miller, *et al.* (2012). "A major genome region underlying artemisinin resistance in malaria." *Science* **336**(6077): 79-82.
- Chen, N., D. W. Wilson, *et al.* (2005). "Origin and dissemination of chloroquine-resistant Plasmodium falciparum with mutant pfcr1 alleles in the Philippines." *Antimicrob Agents Chemother* **49**(5): 2102-2105.
- Cheng, Q., D. E. Kyle, *et al.* (2012). "Artemisinin resistance in Plasmodium falciparum: A process linked to dormancy?" *Int J Parasitol Drugs Drug Resist* **2**: 249-255.
- Cheng, Q. and A. Saul (1994). "The dihydrofolate reductase domain of rodent malarial: point mutations and pyrimethamine resistance." *Mol Biochem Parasitol* **65**(2): 361-363.

- Chico, R. M., R. Pittrof, *et al.* (2008). "Azithromycin-chloroquine and the intermittent preventive treatment of malaria in pregnancy." *Malar J* **7**: 255.
- Chima, R. I., C. A. Goodman, *et al.* (2003). "The economic impact of malaria in Africa: a critical review of the evidence." *Health Policy* **63**(1): 17-36.
- Chotivanich, K., R. Tripura, *et al.* (2014). "Laboratory Detection of Artemisinin-Resistant *Plasmodium falciparum*." *Antimicrob Agents Chemother* **58**(6): 3157-3161.
- Clough, B. and I. R. Wilson (2001). *Antibiotics and the plasmodial plastid organelle*. Totowa, NY, Humana Press.
- Combrinck, J. M., T. E. Mabothe, *et al.* (2013). "Insights into the role of heme in the mechanism of action of antimalarials." *ACS Chem Biol* **8**(1): 133-137.
- Cooper, R. A., M. T. Ferdig, *et al.* (2002). "Alternative mutations at position 76 of the vacuolar transmembrane protein PfCRT are associated with chloroquine resistance and unique stereospecific quinine and quinidine responses in *Plasmodium falciparum*." *Mol Pharmacol* **61**(1): 35-42.
- Cooper, R. A., C. L. Hartwig, *et al.* (2005). "pfcr1 is more than the *Plasmodium falciparum* chloroquine resistance gene: a functional and evolutionary perspective." *Acta Trop* **94**(3): 170-180.
- Cooper, R. A., K. D. Lane, *et al.* (2007). "Mutations in transmembrane domains 1, 4 and 9 of the *Plasmodium falciparum* chloroquine resistance transporter alter susceptibility to chloroquine, quinine and quinidine." *Mol Microbiol* **63**(1): 270-282.
- Corbett, Y., L. Herrera, *et al.* (2004). "A novel DNA-based microfluorimetric method to evaluate antimalarial drug activity." *Am J Trop Med Hyg* **70**(2): 119-124.
- Cowman, A. F., S. Karcz, *et al.* (1991). "A P-glycoprotein homologue of *Plasmodium falciparum* is localized on the digestive vacuole." *J Cell Biol* **113**(5): 1033-1042.
- Cowman, A. F. and A. M. Lew (1990). "Chromosomal rearrangements and point mutations in the DHFR-TS gene of *Plasmodium chabaudi* under antifolate selection." *Mol Biochem Parasitol* **42**(1): 21-29.
- Cox-Singh, J., T. M. Davis, *et al.* (2008). "*Plasmodium knowlesi* malaria in humans is widely distributed and potentially life threatening." *Clin Infect Dis* **46**(2): 165-171.
- Cravo, P. V. L., J. M. R. Carlton, *et al.* (2003). "Genetics of Mefloquine Resistance in the Rodent Malaria Parasite *Plasmodium chabaudi*." *Antimicrobial Agents and Chemotherapy* **47**(2): 709-718.
- Creek, D. J., W. N. Charman, *et al.* (2008). "Relationship between antimalarial activity and heme alkylation for spiro- and dispiro-1,2,4-trioxolane antimalarials." *Antimicrob Agents Chemother* **52**(4): 1291-1296.
- Croft, A. M. (2007). "A lesson learnt: the rise and fall of Lariam and Halfan." *J R Soc Med* **100**(4): 170-174.
- Croft, S. L., S. Duparc, *et al.* (2012). "Review of pyronaridine anti-malarial properties and product characteristics." *Malar J* **11**: 270.
- Cui, L. and X. Z. Su (2009). "Discovery, mechanisms of action and combination therapy of artemisinin." *Expert Rev Anti Infect Ther* **7**(8): 999-1013.
- Culleton, R., A. Martinelli, *et al.* (2005). "Linkage group selection: rapid gene discovery in malaria parasites." *Genome Res* **15**(1): 92-97.
- Curd, F. H., D. G. Davey, *et al.* (1945). "Studies on synthetic antimalarial drugs; some biguanide derivatives as new types of antimalarial substances with both therapeutic and causal prophylactic activity." *Ann Trop Med Parasitol* **39**: 208-216.
- Dahl, E. L. and P. J. Rosenthal (2007). "Multiple antibiotics exert delayed effects against the *Plasmodium falciparum* apicoplast." *Antimicrob Agents Chemother* **51**(10): 3485-3490.
- Dahl, E. L. and P. J. Rosenthal (2008). "Apicoplast translation, transcription and genome replication: targets for antimalarial antibiotics." *Trends Parasitol* **24**(6): 279-284.

- Dahl, E. L., J. L. Shock, *et al.* (2006). "Tetracyclines specifically target the apicoplast of the malaria parasite *Plasmodium falciparum*." *Antimicrob Agents Chemother* **50**(9): 3124-3131.
- Dahlstrom, S., M. I. Veiga, *et al.* (2008). "Diversity of the sarco/endoplasmic reticulum Ca(2+)-ATPase orthologue of *Plasmodium falciparum* (PfATP6)." *Infect Genet Evol* **8**(3): 340-345.
- Dantuma, N. P. and K. Lindsten (2010). "Stressing the ubiquitin-proteasome system." *Cardiovasc Res* **85**(2): 263-271.
- David, K. P., M. Alifrangis, *et al.* (2003). "Atovaquone/proguanil resistance in Africa: a case report." *Scand J Infect Dis* **35**(11-12): 897-898.
- Davis, T. M., T. Y. Hung, *et al.* (2005). "Piperaquine: a resurgent antimalarial drug." *Drugs* **65**(1): 75-87.
- de Vries, P. J. and T. K. Dien (1996). "Clinical pharmacology and therapeutic potential of artemisinin and its derivatives in the treatment of malaria." *Drugs* **52**(6): 818-836.
- del Pilar Crespo, M., T. D. Avery, *et al.* (2008). "Artemisinin and a series of novel endoperoxide antimalarials exert early effects on digestive vacuole morphology." *Antimicrob Agents Chemother* **52**(1): 98-109.
- Desjardins, R. E., C. J. Canfield, *et al.* (1979). "Quantitative assessment of antimalarial activity in vitro by a semiautomated microdilution technique." *Antimicrob Agents Chemother* **16**(6): 710-718.
- Dondorp, A., F. Nosten, *et al.* (2005). "Artesunate versus quinine for treatment of severe *falciparum* malaria: a randomised trial." *Lancet* **366**(9487): 717-725.
- Dondorp, A. M., R. M. Fairhurst, *et al.* (2011). "The threat of artemisinin-resistant malaria." *N Engl J Med* **365**(12): 1073-1075.
- Dondorp, A. M., C. I. Fanello, *et al.* (2010). "Artesunate versus quinine in the treatment of severe *falciparum* malaria in African children (AQUAMAT): an open-label, randomised trial." *Lancet* **376**(9753): 1647-1657.
- Dondorp, A. M., F. Nosten, *et al.* (2009). "Artemisinin resistance in *Plasmodium falciparum* malaria." *N Engl J Med* **361**(5): 455-467.
- Dorn, A., S. R. Vippagunta, *et al.* (1998). "An assessment of drug-haematin binding as a mechanism for inhibition of haematin polymerisation by quinoline antimalarials." *Biochem Pharmacol* **55**(6): 727-736.
- Duc, D. D., P. J. de Vries, *et al.* (1994). "The pharmacokinetics of a single dose of artemisinin in healthy Vietnamese subjects." *Am J Trop Med Hyg* **51**(6): 785-790.
- Dupre, S., D. Urban-Grimal, *et al.* (2004). "Ubiquitin and endocytic internalization in yeast and animal cells." *Biochim Biophys Acta* **1695**(1-3): 89-111.
- Duraisingh, M. T., C. Roper, *et al.* (2000). "Increased sensitivity to the antimalarials mefloquine and artemisinin is conferred by mutations in the *pfmdr1* gene of *Plasmodium falciparum*." *Mol Microbiol* **36**(4): 955-961.
- Eastman, R. T., N. V. Dharia, *et al.* (2011). "Piperaquine resistance is associated with a copy number variation on chromosome 5 in drug-pressured *Plasmodium falciparum* parasites." *Antimicrob Agents Chemother* **55**(8): 3908-3916.
- Ecker, A., A. Lehane, *et al.* (2012). Treatment and prevention of malaria: antimalarial drug chemistry, action and use. Basel, Springer.
- Ecker, A., A. M. Lehane, *et al.* (2012). "PfCRT and its role in antimalarial drug resistance." *Trends Parasitol* **28**(11): 504-514.
- Eckstein-Ludwig, U., R. J. Webb, *et al.* (2003). "Artemisinins target the SERCA of *Plasmodium falciparum*." *Nature* **424**(6951): 957-961.
- Eklund, E. H. and D. A. Fidock (2008). "In vitro evaluations of antimalarial drugs and their relevance to clinical outcomes." *Int J Parasitol* **38**(7): 743-747.

- EMA. (2012). "Press release - European Medicines Agency recommends new anti-malaria treatment for use outside the European Union " Retrieved 08/04/2014, 2014, from <http://www.ema.europa.eu>.
- Eyase, F. L., H. M. Akala, *et al.* (2013). "The role of Pfmdr1 and Pfcr1 in changing chloroquine, amodiaquine, mefloquine and lumefantrine susceptibility in western-Kenya *P. falciparum* samples during 2008-2011." *PLoS One* **8**(5): e64299.
- Falco, E. A., L. G. Goodwin, *et al.* (1951). "2:4-diaminopyrimidines- a new series of antimalarials." *Br J Pharmacol Chemother* **6**(2): 185-200.
- Farnert, A., J. Lindberg, *et al.* (2003). "Evidence of Plasmodium falciparum malaria resistant to atovaquone and proguanil hydrochloride: case reports." *BMJ* **326**(7390): 628-629.
- Ferdig, M. T., R. A. Cooper, *et al.* (2004). "Dissecting the loci of low-level quinine resistance in malaria parasites." *Mol Microbiol* **52**(4): 985-997.
- Ferrari, V. and D. J. Cutler (1991). "Kinetics and thermodynamics of chloroquine and hydroxychloroquine transport across the human erythrocyte membrane." *Biochem Pharmacol* **41**(1): 23-30.
- Ferreira, I. D., D. Lopes, *et al.* (2007). "In vitro assessment of artesunate, artemether and amodiaquine susceptibility and molecular analysis of putative resistance-associated mutations of Plasmodium falciparum from Sao Tome and Principe." *Trop Med Int Health* **12**(3): 353-362.
- Ferreira, I. D., A. Martinelli, *et al.* (2008). "Plasmodium falciparum from Para state (Brazil) shows satisfactory in vitro response to artemisinin derivatives and absence of the S769N mutation in the SERCA-type PfATPase6." *Trop Med Int Health* **13**(2): 199-207.
- Ferrer-Rodriguez, I., J. Perez-Rosado, *et al.* (2004). "Plasmodium yoelii: identification and partial characterization of an MDR1 gene in an artemisinin-resistant line." *J Parasitol* **90**(1): 152-160.
- Fidock, D. A., T. Nomura, *et al.* (2000). "Mutations in the P. falciparum digestive vacuole transmembrane protein PfCRT and evidence for their role in chloroquine resistance." *Mol Cell* **6**(4): 861-871.
- Fitch, C. D. (2004). "Ferriprotoporphyryn IX, phospholipids, and the antimalarial actions of quinoline drugs." *Life Sci* **74**(16): 1957-1972.
- Fivelman, Q. L., G. A. Butcher, *et al.* (2002). "Malarone treatment failure and in vitro confirmation of resistance of Plasmodium falciparum isolate from Lagos, Nigeria." *Malar J* **1**: 1.
- Fogh, S., S. Jepsen, *et al.* (1979). "Chloroquine-resistant Plasmodium falciparum malaria in Kenya." *Trans R Soc Trop Med Hyg* **73**(2): 228-229.
- Foley, M. and L. Tilley (1997). "Quinoline antimalarials: mechanisms of action and resistance." *Int J Parasitol* **27**(2): 231-240.
- Foley, M. and L. Tilley (1998). "Quinoline antimalarials: mechanisms of action and resistance and prospects for new agents." *Pharmacol Ther* **79**(1): 55-87.
- Foote, S. J. and A. F. Cowman (1994). "The mode of action and the mechanism of resistance to antimalarial drugs." *Acta Trop* **56**(2-3): 157-171.
- Foote, S. J., D. E. Kyle, *et al.* (1990). "Several alleles of the multidrug-resistance gene are closely linked to chloroquine resistance in Plasmodium falciparum." *Nature* **345**(6272): 255-258.
- Friesen, J., O. Silvie, *et al.* (2010). "Natural immunization against malaria: causal prophylaxis with antibiotics." *Sci Transl Med* **2**(40): 40ra49.
- Gaillard, T., S. Briolant, *et al.* (2013). "PftetQ and pfmdt copy numbers as predictive molecular markers of decreased ex vivo doxycycline susceptibility in imported Plasmodium falciparum malaria." *Malar J* **12**: 414.



- Gama, B. E., G. A. Pereira-Carvalho, *et al.* (2010). "Plasmodium falciparum isolates from Angola show the StctVMNT haplotype in the pfcr1 gene." Malar J **9**: 174.
- Gavigan, C. S., M. Shen, *et al.* (2007). "Influence of the Plasmodium falciparum P-glycoprotein homologue 1 (pfmdr1 gene product) on the antimalarial action of cyclosporin." J Antimicrob Chemother **59**(2): 197-203.
- Gething, P. W., A. P. Patil, *et al.* (2011). "A new world malaria map: Plasmodium falciparum endemicity in 2010." Malar J **10**: 378.
- Ghorbal, M., M. Gorman, *et al.* (2014). "Genome editing in the human malaria parasite Plasmodium falciparum using the CRISPR-Cas9 system." Nat Biotechnol **32**(8): 819-821.
- Giao, P. T., T. Q. Binh, *et al.* (2001). "Artemisinin for treatment of uncomplicated falciparum malaria: is there a place for monotherapy?" Am J Trop Med Hyg **65**(6): 690-695.
- Girard, M., Z. Reed, *et al.* (2007). "A review of human vaccine research and development: Malaria☆." Vaccine **25**(9): 1567-1580.
- Golenser, J., J. H. Wankine, *et al.* (2006). "Current perspectives on the mechanism of action of artemisinins." Int J Parasitol **36**(14): 1427-1441.
- Goodman, C. D. and G. I. McFadden (2013). "Targeting apicoplasts in malaria parasites." Expert Opin Ther Targets **17**(2): 167-177.
- Greenwood, B. M. (2008). "Control to elimination: implications for malaria research." Trends in Parasitology **24**(10): 449-454.
- Greenwood, B. M., K. Bojang, *et al.* (2005). "Malaria." The Lancet **365**(9469): 1487-1498.
- Greenwood, D. (1992). "The quinine connection." J Antimicrob Chemother **30**(4): 417-427.
- Greenwood, D. (1995). "Historical perspective - Conflicts of interest: the genesis of synthetic antimalarial agents in peace and war." Journal of Antimicrobial Chemotherapy **36**: 857-872.
- Gregson, A. and C. V. Plowe (2005). "Mechanisms of resistance of malaria parasites to antifolates." Pharmacol Rev **57**(1): 117-145.
- Hao, M., D. Jia, *et al.* (2013). "In vitro sensitivities of Plasmodium falciparum isolates from the China-Myanmar border to piperaquine and association with polymorphisms in candidate genes." Antimicrob Agents Chemother **57**(4): 1723-1729.
- Hartwig, C. L., A. S. Rosenthal, *et al.* (2009). "Accumulation of artemisinin trioxane derivatives within neutral lipids of Plasmodium falciparum malaria parasites is endoperoxide-dependent." Biochem Pharmacol **77**(3): 322-336.
- Hassan, A. M., A. Bjorkman, *et al.* (1999). "Synergism of benflumetol and artemether in Plasmodium falciparum." Am J Trop Med Hyg **61**(3): 439-445.
- Hastings, I. M. (2006). "Complex dynamics and stability of resistance to antimalarial drugs." Parasitology **132**(Pt 5): 615-624.
- Hastings, I. M. (2007). "Molecular markers as indicators of antimalarial drug failure rates." Trop Med Int Health **12**(11): 1298-1301.
- Hastings, I. M. and E. M. Hodel (2014). "Pharmacological considerations in the design of anti-malarial drug combination therapies - is matching half-lives enough?" Malar J **13**(1): 62.
- Hastings, I. M., E. L. Korenromp, *et al.* (2007). "The anatomy of a malaria disaster: drug policy choice and mortality in African children." Lancet Infect Dis **7**(11): 739-748.
- Hastings, I. M. and W. M. Watkins (2006). "Tolerance is the key to understanding antimalarial drug resistance." Trends Parasitol **22**(2): 71-77.
- Hastings, I. M., W. M. Watkins, *et al.* (2002). "The evolution of drug-resistant malaria: the role of drug elimination half-life." Philos Trans R Soc Lond B Biol Sci **357**(1420): 505-519.

- Hawley, S. R., P. G. Bray, *et al.* (1996). "Amodiaquine accumulation in *Plasmodium falciparum* as a possible explanation for its superior antimalarial activity over chloroquine." *Mol Biochem Parasitol* **80**(1): 15-25.
- Hayeshi, R., C. Masimirembwa, *et al.* (2008). "Lysosomal trapping of amodiaquine: impact on transport across intestinal epithelia models." *Biopharm Drug Dispos* **29**(6): 324-334.
- Haynes, R. K., W. C. Chan, *et al.* (2007). "The Fe<sup>2+</sup>-mediated decomposition, PfATP6 binding, and antimalarial activities of artemisone and other artemisinins: the unlikelihood of C-centered radicals as bioactive intermediates." *ChemMedChem* **2**(10): 1480-1497.
- Hayton, K. and X. Z. Su (2004). "Genetic and biochemical aspects of drug resistance in malaria parasites." *Curr Drug Targets Infect Disord* **4**(1): 1-10.
- Hegde, A. N. and A. DiAntonio (2002). "Ubiquitin and the synapse." *Nat Rev Neurosci* **3**(11): 854-861.
- Henriques, G., R. L. Hallett, *et al.* (2014a). "Directional selection at the *pfmdr1*, *pfcr1*, *pfubp1* and *pfap2mu* loci of *Plasmodium falciparum* in Kenyan children treated with ACT." *submitted to J Infect Dis : revised version requested*.
- Henriques, G., R. L. Hallett, *et al.* (2014b). "Directional Selection at the *pfmdr1*, *pfcr1*, *pfubp1*, and *pfap2mu* Loci of *Plasmodium falciparum* in Kenyan Children Treated With ACT." *J Infect Dis*.
- Henriques, G., A. Martinelli, *et al.* (2013). "Artemisinin resistance in rodent malaria--mutation in the AP2 adaptor mu-chain suggests involvement of endocytosis and membrane protein trafficking." *Malar J* **12**: 118.
- Hicke, L. (2001). "A new ticket for entry into budding vesicles-ubiquitin." *Cell* **106**(5): 527-530.
- Hicke, L. and R. Dunn (2003). "Regulation of membrane protein transport by ubiquitin and ubiquitin-binding proteins." *Annu Rev Cell Dev Biol* **19**: 141-172.
- Hien, T. T. and N. J. White (1993). "Qinghaosu." *Lancet* **341**(8845): 603-608.
- Hill, A. V. S. (2011). "Vaccines against malaria." *Philosophical Transactions of the Royal Society B: Biological Sciences* **366**(1579): 2806-2814.
- Hill, D. R., J. K. Baird, *et al.* (2006). "Primaquine: report from CDC expert meeting on malaria chemoprophylaxis I." *Am J Trop Med Hyg* **75**(3): 402-415.
- Holmgren, G., J. Hamrin, *et al.* (2007). "Selection of *pfmdr1* mutations after amodiaquine monotherapy and amodiaquine plus artemisinin combination therapy in East Africa." *Infect Genet Evol* **7**(5): 562-569.
- Homewood, C. A., D. C. Warhurst, *et al.* (1972). "Lysosomes, pH and the anti-malarial action of chloroquine." *Nature* **235**(5332): 50-52.
- Howes, R. E., K. E. Battle, *et al.* (2013). "G6PD deficiency: global distribution, genetic variants and primaquine therapy." *Adv Parasitol* **81**: 133-201.
- Hsu, E. (2006). "The history of qing hao in the Chinese materia medica." *Trans R Soc Trop Med Hyg* **100**(6): 505-508.
- Hudson, A. T. (1993). "Atovaquone - a novel broad-spectrum anti-infective drug." *Parasitol Today* **9**(2): 66-68.
- Humphreys, G. S., I. Merinopoulos, *et al.* (2007). "Amodiaquine and artemether-lumefantrine select distinct alleles of the *Plasmodium falciparum* *mdr1* gene in Tanzanian children treated for uncomplicated malaria." *Antimicrob Agents Chemother* **51**(3): 991-997.
- Hunt, P., A. Afonso, *et al.* (2007). "Gene encoding a deubiquitinating enzyme is mutated in artesunate- and chloroquine-resistant rodent malaria parasites." *Molecular Microbiology* **65**(1): 27-40.

- Hunt, P., P. V. Cravo, *et al.* (2004). "Chloroquine resistance in *Plasmodium chabaudi*: are chloroquine-resistance transporter (crt) and multi-drug resistance (mdr1) orthologues involved?" *Mol Biochem Parasitol* **133**(1): 27-35.
- Hunt, P., A. Martinelli, *et al.* (2010). "Experimental evolution, genetic analysis and genome re-sequencing reveal the mutation conferring artemisinin resistance in an isogenic lineage of malaria parasites." *BMC Genomics* **11**: 499.
- Hyde, J. E. (2007). "Drug-resistant malaria - an insight." *FEBS J* **274**(18): 4688-4698.
- Imwong, M., A. M. Dondorp, *et al.* (2010). "Exploring the contribution of candidate genes to artemisinin resistance in *Plasmodium falciparum*." *Antimicrob Agents Chemother* **54**(7): 2886-2892.
- Ivanetich, K. M. and D. V. Santi (1990). "Bifunctional thymidylate synthase-dihydrofolate reductase in protozoa." *FASEB J* **4**(6): 1591-1597.
- Jamaludin, A., M. Mohamed, *et al.* (1988). "Single-dose comparative kinetics and bioavailability study of quinine hydrochloride, quinidine sulfate and quinidine bisulfate sustained-release in healthy male volunteers." *Acta Leiden* **57**(1): 39-46.
- Jambou, R., E. Legrand, *et al.* (2005). "Resistance of *Plasmodium falciparum* field isolates to in-vitro artemether and point mutations of the SERCA-type PfATPase6." *The Lancet* **366**(9501): 1960-1963.
- Jambou, R., A. Martinelli, *et al.* (2010). "Geographic structuring of the *Plasmodium falciparum* sarco(endo)plasmic reticulum Ca<sup>2+</sup> ATPase (PfSERCA) gene diversity." *PLoS One* **5**(2): e9424.
- Jefford, C. W. (2001). "Why artemisinin and certain synthetic peroxides are potent antimalarials. Implications for the mode of action." *Curr Med Chem* **8**(15): 1803-1826.
- Kayentao, K., O. K. Doumbo, *et al.* (2012). "Pyronaridine-artesunate granules versus artemether-lumefantrine crushed tablets in children with *Plasmodium falciparum* malaria: a randomized controlled trial." *Malar J* **11**: 364.
- Kelly, B. T. and D. J. Owen (2011). "Endocytic sorting of transmembrane protein cargo." *Curr Opin Cell Biol* **23**(4): 404-412.
- Kim, H., M. Barroso, *et al.* (1997). "Experimentally induced changes in the endocytic traffic of P-glycoprotein alter drug resistance of cancer cells." *Am J Physiol* **273**(2 Pt 1): C687-702.
- Kinga Modrzynska, K., A. Creasey, *et al.* (2012). "Quantitative genome re-sequencing defines multiple mutations conferring chloroquine resistance in rodent malaria." *BMC Genomics* **13**: 106.
- Kitchen, L. W., D. W. Vaughn, *et al.* (2006). "Role of US military research programs in the development of US Food and Drug Administration--approved antimalarial drugs." *Clin Infect Dis* **43**(1): 67-71.
- Klayman, D. L. (1985). "Qinghaosu (artemisinin): an antimalarial drug from China." *Science* **228**(4703): 1049-1055.
- Klionsky, D. J. and B. A. Schulman (2014). "Dynamic regulation of macroautophagy by distinctive ubiquitin-like proteins." *Nat Struct Mol Biol* **21**(4): 336-345.
- Kokwaro, G., L. Mwai, *et al.* (2007). "Artemether/lumefantrine in the treatment of uncomplicated falciparum malaria." *Expert Opin Pharmacother* **8**(1): 75-94.
- Kolling, R. and C. P. Hollenberg (1994). "The ABC-transporter Ste6 accumulates in the plasma membrane in a ubiquitinated form in endocytosis mutants." *EMBO J* **13**(14): 3261-3271.
- Komander, D. and M. Rape (2012). "The ubiquitin code." *Annu Rev Biochem* **81**: 203-229.
- Korolchuk, V. I., F. M. Menzies, *et al.* (2010). "Mechanisms of cross-talk between the ubiquitin-proteasome and autophagy-lysosome systems." *FEBS Lett* **584**(7): 1393-1398.

- Korsinczky, M., N. Chen, *et al.* (2000). "Mutations in *Plasmodium falciparum* cytochrome b that are associated with atovaquone resistance are located at a putative drug-binding site." *Antimicrob Agents Chemother* **44**(8): 2100-2108.
- Krishna, S., A. Uhlemann, *et al.* (2004a). "Artemisinins: mechanisms of action and potential for resistance." *Drug Resistance Updates* **7**(4-5): 233-244.
- Krishna, S., A. C. Uhlemann, *et al.* (2004b). "Artemisinins: mechanisms of action and potential for resistance." *Drug Resist Updat* **7**(4-5): 233-244.
- Krugliak, M., J. Zhang, *et al.* (2002). "Intraerythrocytic *Plasmodium falciparum* utilizes only a fraction of the amino acids derived from the digestion of host cell cytosol for the biosynthesis of its proteins." *Mol Biochem Parasitol* **119**(2): 249-256.
- Kublin, J. G., J. F. Cortese, *et al.* (2003). "Reemergence of chloroquine-sensitive *Plasmodium falciparum* malaria after cessation of chloroquine use in Malawi." *J Infect Dis* **187**(12): 1870-1875.
- Kumpornsin, K., C. Modchang, *et al.* (2014). "Origin of robustness in generating drug-resistant malaria parasites." *Mol Biol Evol* **31**(7): 1649-1660.
- Kyaw, M. P., M. H. Nyunt, *et al.* (2013). "Reduced susceptibility of *Plasmodium falciparum* to artesunate in southern Myanmar." *PLoS One* **8**(3): e57689.
- Lambros, C. and J. P. Vanderberg (1979). "Synchronization of *Plasmodium falciparum* erythrocytic stages in culture." *J Parasitol* **65**(3): 418-420.
- Laufer, M. K. (2009). "Monitoring antimalarial drug efficacy: current challenges." *Curr Infect Dis Rep* **11**(1): 59-65.
- Le Bras, J. and R. Durand (2003). "The mechanisms of resistance to antimalarial drugs in *Plasmodium falciparum*." *Fundam Clin Pharmacol* **17**(2): 147-153.
- Le Roy, C. and J. L. Wrana (2005). "Clathrin- and non-clathrin-mediated endocytic regulation of cell signalling." *Nat Rev Mol Cell Biol* **6**(2): 112-126.
- Lee, M. C., P. A. Moura, *et al.* (2008). "*Plasmodium falciparum* Sec24 marks transitional ER that exports a model cargo via a diacidic motif." *Mol Microbiol* **68**(6): 1535-1546.
- Legrand, E., M. Demar, *et al.* (2007). "First case of emergence of atovaquone resistance in *Plasmodium falciparum* during second-line atovaquone-proguanil treatment in South America." *Antimicrob Agents Chemother* **51**(6): 2280-2281.
- Lehane, A. M. and K. Kirk (2008). "Chloroquine resistance-conferring mutations in *pfprt* give rise to a chloroquine-associated H<sup>+</sup> leak from the malaria parasite's digestive vacuole." *Antimicrob Agents Chemother* **52**(12): 4374-4380.
- LeRoux, M., V. Lakshmanan, *et al.* (2009). "*Plasmodium falciparum* biology: analysis of in vitro versus in vivo growth conditions." *Trends Parasitol* **25**(10): 474-481.
- Lew, V. L., T. Tiffert, *et al.* (2003). "Excess hemoglobin digestion and the osmotic stability of *Plasmodium falciparum*-infected red blood cells." *Blood* **101**(10): 4189-4194.
- Li, W., W. Mo, *et al.* (2005). "Yeast model uncovers dual roles of mitochondria in action of artemisinin." *PLoS Genet* **1**(3): e36.
- Lin, J. T., J. J. Juliano, *et al.* (2010). "Drug-Resistant Malaria: The Era of ACT." *Curr Infect Dis Rep* **12**(3): 165-173.
- Loeb, F. C., W. M.; Coatney, G. R.; Coggeshall, L. T.; Dieuaide, F. R.; Dochez, A. R.; Hakansson, E. G.; Marshall E. K.; Marvel, C. S.; McCoy, O. R.; Saper, J. J.; Sebrell, W. H.; Shannon, J. A.; Carden G. A. (1946). "ACTIVITY of a new antimalarial agent, chloroquine (SN 7618)." *J Am Med Assoc* **130**: 1069.
- Looareesuwan, S., D. E. Kyle, *et al.* (1996). "Clinical study of pyronaridine for the treatment of acute uncomplicated *falciparum* malaria in Thailand." *Am J Trop Med Hyg* **54**(2): 205-209.
- Malaney, P., A. Spielman, *et al.* (2004). "The malaria gap." *Am J Trop Med Hyg* **71**(2 Suppl): 141-146.

- Marfurt, J., T. A. Smith, *et al.* (2010). "Plasmodium falciparum resistance to anti-malarial drugs in Papua New Guinea: evaluation of a community-based approach for the molecular monitoring of resistance." *Malar J* **9**: 8.
- Martin, R. E. and K. Kirk (2004). "The malaria parasite's chloroquine resistance transporter is a member of the drug/metabolite transporter superfamily." *Mol Biol Evol* **21**(10): 1938-1949.
- Matuschewski, K. and A.-K. Mueller (2007). "Vaccines against malaria - an update." *FEBS Journal* **274**(18): 4680-4687.
- Mehlotra, R. K., H. Fujioka, *et al.* (2001). "Evolution of a unique Plasmodium falciparum chloroquine-resistance phenotype in association with pfcrt polymorphism in Papua New Guinea and South America." *Proc Natl Acad Sci U S A* **98**(22): 12689-12694.
- Meshnick, S. R. (1994a). "Free radicals and antioxidants." *Lancet* **344**(8934): 1441-1442.
- Meshnick, S. R. (1994b). "The mode of action of antimalarial endoperoxides." *Trans R Soc Trop Med Hyg* **88 Suppl 1**: S31-32.
- Meshnick, S. R. (2002). "Artemisinin: mechanisms of action, resistance and toxicity." *Int J Parasitol* **32**(13): 1655-1660.
- Meshnick, S. R. and M. J. Dobson (2001). The History of Antimalarial Drugs. *Antimalarial Chemotherapy - Mechanisms of Action, Resistance, and New Directions in Drug Discovery*. P. J. Rosenthal. Totowa, New Jersey, Humana Press: 15-25.
- Meshnick, S. R., T. E. Taylor, *et al.* (1996). "Artemisinin and the antimalarial endoperoxides: from herbal remedy to targeted chemotherapy." *Microbiol Rev* **60**(2): 301-315.
- Meshnick, S. R., A. Thomas, *et al.* (1991). "Artemisinin (qinghaosu): the role of intracellular hemozoin in its mechanism of antimalarial action." *Mol Biochem Parasitol* **49**(2): 181-189.
- Meshnick, S. R., Y. Z. Yang, *et al.* (1993). "Iron-dependent free radical generation from the antimalarial agent artemisinin (qinghaosu)." *Antimicrob Agents Chemother* **37**(5): 1108-1114.
- Miotto, O., J. Almagro-Garcia, *et al.* (2013). "Multiple populations of artemisinin-resistant Plasmodium falciparum in Cambodia." *Nat Genet* **45**(6): 648-655.
- Mita, T., J. Ohashi, *et al.* (2014). "Ordered accumulation of mutations conferring resistance to sulfadoxine-pyrimethamine in the Plasmodium falciparum parasite." *J Infect Dis* **209**(1): 130-139.
- Mkulama, M. A., S. Chishimba, *et al.* (2008). "Escalating Plasmodium falciparum antifolate drug resistance mutations in Macha, rural Zambia." *Malar J* **7**: 87.
- Mu, J., M. T. Ferdig, *et al.* (2003). "Multiple transporters associated with malaria parasite responses to chloroquine and quinine." *Mol Microbiol* **49**(4): 977-989.
- Muller, I. B. and J. E. Hyde (2010). "Antimalarial drugs: modes of action and mechanisms of parasite resistance." *Future Microbiol* **5**(12): 1857-1873.
- Muller, I. B. and J. E. Hyde (2013). "Folate metabolism in human malaria parasites--75 years on." *Mol Biochem Parasitol* **188**(1): 63-77.
- Musset, L., J. Le Bras, *et al.* (2007). "Parallel evolution of adaptive mutations in Plasmodium falciparum mitochondrial DNA during atovaquone-proguanil treatment." *Mol Biol Evol* **24**(8): 1582-1585.
- Mwai, L., A. Diriyee, *et al.* (2012). "Genome wide adaptations of Plasmodium falciparum in response to lumefantrine selective drug pressure." *PLoS One* **7**(2): e31623.
- Mwangi, J. M. and L. C. Ranford-Cartwright (2013). "Genetic and genomic approaches for the discovery of parasite genes involved in antimalarial drug resistance." *Parasitology* **140**(12): 1455-1467.
- Nijman, S. M., M. P. Luna-Vargas, *et al.* (2005). "A genomic and functional inventory of deubiquitinating enzymes." *Cell* **123**(5): 773-786.

- Nkrumah, L. J., R. A. Muhle, *et al.* (2006). "Efficient site-specific integration in *Plasmodium falciparum* chromosomes mediated by mycobacteriophage Bxb1 integrase." Nat Methods **3**(8): 615-621.
- Nkrumah, L. J., P. M. Riegelhaupt, *et al.* (2009). "Probing the multifactorial basis of *Plasmodium falciparum* quinine resistance: evidence for a strain-specific contribution of the sodium-proton exchanger PfNHE." Mol Biochem Parasitol **165**(2): 122-131.
- Noedl, H., Y. Se, *et al.* (2008). "Evidence of artemisinin-resistant malaria in western Cambodia." N Engl J Med **359**(24): 2619-2620.
- Noedl, H., Y. Se, *et al.* (2010). "Artemisinin resistance in Cambodia: a clinical trial designed to address an emerging problem in Southeast Asia." Clin Infect Dis **51**(11): e82-89.
- Noedl, H., W. H. Wernsdorfer, *et al.* (2002). "Histidine-rich protein II: a novel approach to malaria drug sensitivity testing." Antimicrob Agents Chemother **46**(6): 1658-1664.
- Noedl, H., C. Wongsrichanalai, *et al.* (2003). "Malaria drug-sensitivity testing: new assays, new perspectives." Trends Parasitol **19**(4): 175-181.
- Nosten, F., F. ter Kuile, *et al.* (1991). "Mefloquine-resistant falciparum malaria on the Thai-Burmese border." Lancet **337**(8750): 1140-1143.
- Nosten, F. and N. J. White (2007). "Artemisinin-based combination treatment of falciparum malaria." Am J Trop Med Hyg **77**(6 Suppl): 181-192.
- Nsoby, S. L., C. Dokomajilar, *et al.* (2007). "Resistance-mediating *Plasmodium falciparum* pfcrt and pfmdr1 alleles after treatment with artesunate-amodiaquine in Uganda." Antimicrob Agents Chemother **51**(8): 3023-3025.
- Nyunt, M. M. and C. V. Plowe (2007). "Pharmacologic advances in the global control and treatment of malaria: combination therapy and resistance." Clin Pharmacol Ther **82**(5): 601-605.
- Nzila, A. (2006). "The past, present and future of antifolates in the treatment of *Plasmodium falciparum* infection." J Antimicrob Chemother **57**(6): 1043-1054.
- Nzila, A. and L. Mwai (2010). "In vitro selection of *Plasmodium falciparum* drug-resistant parasite lines." J Antimicrob Chemother **65**(3): 390-398.
- O'Meara, W. P., J. N. Mangeni, *et al.* (2010). "Changes in the burden of malaria in sub-Saharan Africa." Lancet Infect Dis **10**(8): 545-555.
- O'Neill, P. M., V. E. Barton, *et al.* (2010). "The molecular mechanism of action of artemisinin--the debate continues." Molecules **15**(3): 1705-1721.
- O'Neill, P. M., L. P. Bishop, *et al.* (2000). "Biomimetic Fe(II)-mediated degradation of arteflene (Ro-42-1611). The first EPR spin-trapping evidence for the previously postulated secondary carbon-centered cyclohexyl radical." J Org Chem **65**(5): 1578-1582.
- O'Neill, P. M., V. E. Barton, *et al.* (2012a). 4-Aminoquinolines: Chloroquine, Amodiaquine and Next-Generation Analogues. Treatment and Prevention of Malaria: Antimalarial Drug Chemistry, Action and Use. H. M. Staines and S. Krishna. Basel, Springer Basel: 19-43.
- O'Neill, P. M., V. E. Barton, *et al.* (2012b). 4-Aminoquinolines: Chloroquine, Amodiaquine and Next-Generation Analogues. Basel, Springer Basel AG.
- Ochong, E. O., I. V. van den Broek, *et al.* (2003). "Short report: association between chloroquine and amodiaquine resistance and allelic variation in the *Plasmodium falciparum* multiple drug resistance 1 gene and the chloroquine resistance transporter gene in isolates from the upper Nile in southern Sudan." Am J Trop Med Hyg **69**(2): 184-187.
- Okombo, J., E. Ohuma, *et al.* (2011). "Update on genetic markers of quinine resistance in *Plasmodium falciparum*." Mol Biochem Parasitol **177**(2): 77-82.

- Okorosobo, T., F. Okorosobo, *et al.* (2011). "Economic Burden of Malaria in six Countries of Africa." European Journal of Business and Management **3**(6): 42-63.
- Olliaro, P. (2005). "Drug resistance hampers our capacity to roll back malaria." Clin Infect Dis **41 Suppl 4**: S247-257.
- Olliaro, P., C. Nevill, *et al.* (1996). "Systematic review of amodiaquine treatment in uncomplicated malaria." Lancet **348**(9036): 1196-1201.
- Olliaro, P. L., R. K. Haynes, *et al.* (2001). "Possible modes of action of the artemisinin-type compounds." Trends Parasitol **17**(3): 122-126.
- Olliaro, P. L. and W. R. Taylor (2004). "Developing artemisinin based drug combinations for the treatment of drug resistant falciparum malaria: A review." J Postgrad Med **50**(1): 40-44.
- Overbosch, D., H. Schilthuis, *et al.* (2001). "Atovaquone-proguanil versus mefloquine for malaria prophylaxis in nonimmune travelers: results from a randomized, double-blind study." Clin Infect Dis **33**(7): 1015-1021.
- Padua, R. A. (1981). "Plasmodium chabaudi: genetics of resistance to chloroquine." Exp Parasitol **52**(3): 419-426.
- Pascual, A., M. Madamet, *et al.* (2013). "In vitro piperazine susceptibility is not associated with the Plasmodium falciparum chloroquine resistance transporter gene." Malar J **12**: 431.
- Peters, P. J., M. C. Thigpen, *et al.* (2007). "Safety and toxicity of sulfadoxine/pyrimethamine: implications for malaria prevention in pregnancy using intermittent preventive treatment." Drug Saf **30**(6): 481-501.
- Peters, W. (1982). "Antimalarial drug resistance: an increasing problem." Br Med Bull **38**(2): 187-192.
- Peters, W. (1985). "The problem of drug resistance in malaria." Parasitology **90 ( Pt 4)**: 705-715.
- Peters, W. (1987). Chemotherapy and Drug Resistance in Malaria. London, Academic Press.
- Petersen, E. (1987). "In vitro susceptibility of Plasmodium falciparum malaria to pyrimethamine, sulfadoxine, trimethoprim and sulfamethoxazole, singly and in combination." Trans R Soc Trop Med Hyg **81**(2): 238-241.
- Petersen, I., R. Eastman, *et al.* (2011). "Drug-resistant malaria: molecular mechanisms and implications for public health." FEBS Lett **585**(11): 1551-1562.
- Peterson, D. S., D. Walliker, *et al.* (1988). "Evidence that a point mutation in dihydrofolate reductase-thymidylate synthase confers resistance to pyrimethamine in falciparum malaria." Proc Natl Acad Sci U S A **85**(23): 9114-9118.
- Picot, S., P. Olliaro, *et al.* (2009). "A systematic review and meta-analysis of evidence for correlation between molecular markers of parasite resistance and treatment outcome in falciparum malaria." Malar J **8**: 89.
- Plowe, C. V., A. Djimde, *et al.* (1995). "Pyrimethamine and proguanil resistance-conferring mutations in Plasmodium falciparum dihydrofolate reductase: polymerase chain reaction methods for surveillance in Africa." Am J Trop Med Hyg **52**(6): 565-568.
- Plowe, C. V., C. Roper, *et al.* (2007). "World Antimalarial Resistance Network (WARN) III: molecular markers for drug resistant malaria." Malar J **6**: 121.
- Posner, G. H., D. Wang, *et al.* (1995). "Further evidence supporting the importance of and the restrictions on a carbon-centered radical for high antimalarial activity of 1,2,4-trioxanes like artemisinin." J Med Chem **38**(13): 2273-2275.
- Pradines, B., A. Tall, *et al.* (1998). "In-vitro activity of pyronaridine and amodiaquine against African isolates (Senegal) of Plasmodium falciparum in comparison with standard antimalarial agents." J Antimicrob Chemother **42**(3): 333-339.
- Premji, Z. G. (2009). "Coartem: the journey to the clinic." Malar J **8 Suppl 1**: S3.

- Price, R. N., N. M. Douglas, *et al.* (2009). "New developments in *Plasmodium vivax* malaria: severe disease and the rise of chloroquine resistance." *Curr Opin Infect Dis* **22**(5): 430-435.
- Price, R. N., F. Nosten, *et al.* (1996). "Effects of artemisinin derivatives on malaria transmissibility." *Lancet* **347**(9016): 1654-1658.
- Price, R. N., A. C. Uhlemann, *et al.* (2004). "Mefloquine resistance in *Plasmodium falciparum* and increased *pfmdr1* gene copy number." *Lancet* **364**(9432): 438-447.
- Price, R. N., A. C. Uhlemann, *et al.* (2006). "Molecular and pharmacological determinants of the therapeutic response to artemether-lumefantrine in multidrug-resistant *Plasmodium falciparum* malaria." *Clin Infect Dis* **42**(11): 1570-1577.
- Raynes, K. (1999). "Bisquinoline antimalarials: their role in malaria chemotherapy." *Int J Parasitol* **29**(3): 367-379.
- Reed, M. B., K. J. Saliba, *et al.* (2000). "Pgh1 modulates sensitivity and resistance to multiple antimalarials in *Plasmodium falciparum*." *Nature* **403**(6772): 906-909.
- Ringwald, P., J. Bickii, *et al.* (1996). "Randomised trial of pyronaridine versus chloroquine for acute uncomplicated falciparum malaria in Africa." *Lancet* **347**(8993): 24-28.
- Ringwald, P., J. Bickii, *et al.* (1998). "Efficacy of oral pyronaridine for the treatment of acute uncomplicated falciparum malaria in African children." *Clin Infect Dis* **26**(4): 946-953.
- Robert, A., F. Benoit-Vical, *et al.* (2005). "The antimalarial drug artemisinin alkylates heme in infected mice." *Proc Natl Acad Sci U S A* **102**(38): 13676-13680.
- Rodrigues, L. A., G. Henriques, *et al.* (2010). "Experimental evolution of resistance to artemisinin combination therapy results in amplification of the *mdr1* gene in a rodent malaria parasite." *PLoS One* **5**(7): e11593.
- Roepe, P. D. (2009). "Molecular and physiologic basis of quinoline drug resistance in *Plasmodium falciparum* malaria." *Future Microbiol* **4**(4): 441-455.
- Rogers, W. O., R. Sem, *et al.* (2009). "Failure of artesunate-mefloquine combination therapy for uncomplicated *Plasmodium falciparum* malaria in southern Cambodia." *Malar J* **8**: 10.
- Rohrbach, P., C. P. Sanchez, *et al.* (2006). "Genetic linkage of *pfmdr1* with food vacuolar solute import in *Plasmodium falciparum*." *EMBO J* **25**(13): 3000-3011.
- Ronn, A. M., H. A. Msangeni, *et al.* (1996). "High level of resistance of *Plasmodium falciparum* to sulfadoxine-pyrimethamine in children in Tanzania." *Trans R Soc Trop Med Hyg* **90**(2): 179-181.
- Rosario, V. E. (1976). "Genetics of chloroquine resistance in malaria parasites." *Nature* **261**(5561): 585-586.
- Rosenthal, P. J. (2008). "Artesunate for the treatment of severe falciparum malaria." *N Engl J Med* **358**(17): 1829-1836.
- Rubio, J. P. and A. F. Cowman (1996). "The ATP-binding cassette (ABC) gene family of *Plasmodium falciparum*." *Parasitol Today* **12**(4): 135-140.
- Rueangweerayut, R., A. P. Phyto, *et al.* (2012). "Pyronaridine-artesunate versus mefloquine plus artesunate for malaria." *N Engl J Med* **366**(14): 1298-1309.
- Sa, J. M., J. L. Chong, *et al.* (2011). "Malaria drug resistance: new observations and developments." *Essays Biochem* **51**: 137-160.
- Sa, J. M., O. Twu, *et al.* (2009). "Geographic patterns of *Plasmodium falciparum* drug resistance distinguished by differential responses to amodiaquine and chloroquine." *Proc Natl Acad Sci U S A* **106**(45): 18883-18889.
- Sachs, J. and P. Malaney (2002). "The economic and social burden of malaria." *Nature* **415**(6872): 680-685.
- Saliba, K. J., P. I. Folb, *et al.* (1998). "Role for the plasmodium falciparum digestive vacuole in chloroquine resistance." *Biochem Pharmacol* **56**(3): 313-320.



- Sanchez, C. P., W. D. Stein, *et al.* (2007). "Is PfCRT a channel or a carrier? Two competing models explaining chloroquine resistance in *Plasmodium falciparum*." Trends Parasitol **23**(7): 332-339.
- Sanchez, C. P., W. D. Stein, *et al.* (2008). "Dissecting the components of quinine accumulation in *Plasmodium falciparum*." Mol Microbiol **67**(5): 1081-1093.
- Saunders, D. L., P. Vanachayangkul, *et al.* (2014). "Dihydroartemisinin-piperaquine failure in Cambodia." N Engl J Med **371**(5): 484-485.
- Sawa, P., S. A. Shekalaghe, *et al.* (2013). "Malaria transmission after artemether-lumefantrine and dihydroartemisinin-piperaquine: a randomized trial." J Infect Dis **207**(11): 1637-1645.
- Schildbach, S., W. H. Wernsdorfer, *et al.* (1990). "In vitro sensitivity of multiresistant *Plasmodium falciparum* to new candidate antimalarial drugs in western Thailand." Southeast Asian J Trop Med Public Health **21**(1): 29-38.
- Schlitzer, M. (2007). "Malaria chemotherapeutics part I: History of antimalarial drug development, currently used therapeutics, and drugs in clinical development." ChemMedChem **2**(7): 944-986.
- Schwank, S., C. J. Sutherland, *et al.* (2010). "Promiscuous expression of alpha-tubulin II in maturing male and female *Plasmodium falciparum* gametocytes." PLoS One **5**(12): e14470.
- Schwobel, B., M. Alifrangis, *et al.* (2003). "Different mutation patterns of atovaquone resistance to *Plasmodium falciparum* in vitro and in vivo: rapid detection of codon 268 polymorphisms in the cytochrome b as potential in vivo resistance marker." Malar J **2**: 5.
- Shang, F. and A. Taylor (2011). "Ubiquitin-proteasome pathway and cellular responses to oxidative stress." Free Radic Biol Med **51**(1): 5-16.
- Shanks, G. D. (1994). "1993 Sir Henry Wellcome Medal and Prize recipient. The rise and fall of mefloquine as an antimalarial drug in South East Asia." Mil Med **159**(4): 275-281.
- Shanks, G. D., J. J. Karwacki, *et al.* (1989). "Malaria prophylaxis during military operations in Thailand." Mil Med **154**(10): 500-502.
- Sibley, C. H., J. E. Hyde, *et al.* (2001). "Pyrimethamine-sulfadoxine resistance in *Plasmodium falciparum*: what next?" Trends Parasitol **17**(12): 582-588.
- Sidhu, A. B., A. C. Uhlemann, *et al.* (2006). "Decreasing pfmdr1 copy number in *Plasmodium falciparum* malaria heightens susceptibility to mefloquine, lumefantrine, halofantrine, quinine, and artemisinin." J Infect Dis **194**(4): 528-535.
- Sidhu, A. B., S. G. Valderramos, *et al.* (2005). "pfmdr1 mutations contribute to quinine resistance and enhance mefloquine and artemisinin sensitivity in *Plasmodium falciparum*." Mol Microbiol **57**(4): 913-926.
- Sidhu, A. B., D. Verdier-Pinard, *et al.* (2002). "Chloroquine resistance in *Plasmodium falciparum* malaria parasites conferred by pfcr1 mutations." Science **298**(5591): 210-213.
- Siegel, R. E. and F. N. Poynter (1962). "Robert Talbor, Charles Li, and Cinchona a Contemporary Document." Med Hist **6**(1): 82-85.
- Singh, B., L. Kim Sung, *et al.* (2004). "A large focus of naturally acquired *Plasmodium knowlesi* infections in human beings." Lancet **363**(9414): 1017-1024.
- Sisowath, C., P. E. Ferreira, *et al.* (2007). "The role of pfmdr1 in *Plasmodium falciparum* tolerance to artemether-lumefantrine in Africa." Trop Med Int Health **12**(6): 736-742.
- Sisowath, C., I. Petersen, *et al.* (2009). "In vivo selection of *Plasmodium falciparum* parasites carrying the chloroquine-susceptible pfcr1 K76 allele after treatment with artemether-lumefantrine in Africa." J Infect Dis **199**(5): 750-757.

- Snewin, V. A., S. M. England, *et al.* (1989). "Characterisation of the dihydrofolate reductase-thymidylate synthetase gene from human malaria parasites highly resistant to pyrimethamine." Gene **76**(1): 41-52.
- Srivastava, I. K., H. Rottenberg, *et al.* (1997). "Atovaquone, a broad spectrum antiparasitic drug, collapses mitochondrial membrane potential in a malarial parasite." J Biol Chem **272**(7): 3961-3966.
- Stepniewska, K., W. R. Taylor, *et al.* (2004). "In vivo assessment of drug efficacy against Plasmodium falciparum malaria: duration of follow-up." Antimicrob Agents Chemother **48**(11): 4271-4280.
- Stepniewska, K. and N. J. White (2008). "Pharmacokinetic determinants of the window of selection for antimalarial drug resistance." Antimicrob Agents Chemother **52**(5): 1589-1596.
- Straimer, J., N. F. Gnädig, *et al.* (2015). "Drug resistance. K13-propeller mutations confer artemisinin resistance in Plasmodium falciparum clinical isolates." Science **347**(6220): 428-431.
- Su, X., L. A. Kirkman, *et al.* (1997). "Complex polymorphisms in an approximately 330 kDa protein are linked to chloroquine-resistant P. falciparum in Southeast Asia and Africa." Cell **91**(5): 593-603.
- Sullivan, D. J., Jr., H. Matile, *et al.* (1998). "A common mechanism for blockade of heme polymerization by antimalarial quinolines." J Biol Chem **273**(47): 31103-31107.
- Summers, R. L., M. N. Nash, *et al.* (2012). "Know your enemy: understanding the role of PfCRT in drug resistance could lead to new antimalarial tactics." Cell Mol Life Sci **69**(12): 1967-1995.
- Sutherland, C. J., M. Laundry, *et al.* (2008). "Mutations in the Plasmodium falciparum cytochrome b gene are associated with delayed parasite recrudescence in malaria patients treated with atovaquone-proguanil." Malar J **7**: 240.
- Sutherland, C. J., N. Tanomsing, *et al.* (2010). "Two nonrecombining sympatric forms of the human malaria parasite Plasmodium ovale occur globally." J Infect Dis **201**(10): 1544-1550.
- Takala-Harrison, S., T. G. Clark, *et al.* (2013). "Genetic loci associated with delayed clearance of Plasmodium falciparum following artemisinin treatment in Southeast Asia." Proc Natl Acad Sci U S A **110**(1): 240-245.
- Talisuna, A. O., P. Bloland, *et al.* (2004). "History, dynamics, and public health importance of malaria parasite resistance." Clin Microbiol Rev **17**(1): 235-254.
- Tan, K. R., A. J. Magill, *et al.* (2011). "Doxycycline for malaria chemoprophylaxis and treatment: report from the CDC expert meeting on malaria chemoprophylaxis." Am J Trop Med Hyg **84**(4): 517-531.
- Taylor, S. M., C. M. Parobek, *et al.* (2015). "Absence of Putative Artemisinin Resistance Mutations Among Plasmodium falciparum in Sub-Saharan Africa: A Molecular Epidemiologic Study." J Infect Dis **211**(5): 680-688.
- Taylor, W. R. and N. J. White (2004). "Antimalarial drug toxicity: a review." Drug Saf **27**(1): 25-61.
- Teuscher, F., N. Chen, *et al.* (2012). "Phenotypic changes in artemisinin-resistant Plasmodium falciparum lines in vitro: evidence for decreased sensitivity to dormancy and growth inhibition." Antimicrob Agents Chemother **56**(1): 428-431.
- Thriemer, K., R. Haque, *et al.* (2006). "Therapeutic efficacy of quinine plus sulfadoxine-pyremethamine for the treatment of uncomplicated falciparum malaria in Bangladesh." Am J Trop Med Hyg **75**(4): 645-649.
- Tinto, H., L. N. Bonkian, *et al.* (2014). "Ex vivo anti-malarial drugs sensitivity profile of Plasmodium falciparum field isolates from Burkina Faso five years after the national policy change." Malar J **13**(1): 207.

- Tinto, H., C. Rwagacondo, *et al.* (2006). "In-vitro susceptibility of Plasmodium falciparum to monodesethylamodiaquine, dihydroartemisinin and quinine in an area of high chloroquine resistance in Rwanda." Trans R Soc Trop Med Hyg **100**(6): 509-514.
- Trager, W. and J. B. Jensen (1976). "Human malaria parasites in continuous culture." Science **193**(4254): 673-675.
- Tran, T. H., C. Dolecek, *et al.* (2004). "Dihydroartemisinin-piperaquine against multidrug-resistant Plasmodium falciparum malaria in Vietnam: randomised clinical trial." Lancet **363**(9402): 18-22.
- Trape, J. F. (2001). "The public health impact of chloroquine resistance in Africa." Am J Trop Med Hyg **64**(1-2 Suppl): 12-17.
- Uhlemann, A. C., A. Cameron, *et al.* (2005). "A single amino acid residue can determine the sensitivity of SERCAs to artemisinins." Nat Struct Mol Biol **12**(7): 628-629.
- Valderramos, S. G., D. Scanfled, *et al.* (2010). "Investigations into the role of the Plasmodium falciparum SERCA (PfATP6) L263E mutation in artemisinin action and resistance." Antimicrob Agents Chemother **54**(9): 3842-3852.
- Vale, N., R. Moreira, *et al.* (2009). "Primaquine revisited six decades after its discovery." Eur J Med Chem **44**(3): 937-953.
- van Schalkwyk, D. A., R. Burrow, *et al.* (2013). "Culture-adapted Plasmodium falciparum isolates from UK travellers: in vitro drug sensitivity, clonality and drug resistance markers." Malar J **12**: 320.
- Vennerstrom, J. L., S. Arbe-Barnes, *et al.* (2004). "Identification of an antimalarial synthetic trioxolane drug development candidate." Nature **430**(7002): 900-904.
- Vestergaard, L. S. and P. Ringwald (2007). "Responding to the challenge of antimalarial drug resistance by routine monitoring to update national malaria treatment policies." Am J Trop Med Hyg **77**(6 Suppl): 153-159.
- Vijaykadga, S., C. Rojanawatsirivej, *et al.* (2006). "In vivo sensitivity monitoring of mefloquine monotherapy and artesunate-mefloquine combinations for the treatment of uncomplicated falciparum malaria in Thailand in 2003." Trop Med Int Health **11**(2): 211-219.
- Vivas, L., L. Rattray, *et al.* (2008). "Anti-malarial efficacy of pyronaridine and artesunate in combination in vitro and in vivo." Acta Trop **105**(3): 222-228.
- Walker, D. J., J. L. Pitsch, *et al.* (2000). "Mechanisms of artemisinin resistance in the rodent malaria pathogen Plasmodium yoelii." Antimicrob Agents Chemother **44**(2): 344-347.
- Walliker, D., R. Carter, *et al.* (1975). "Genetic studies on Plasmodium chabaudi: recombination between enzyme markers." Parasitology **70**(1): 19-24.
- Wang, J., L. Huang, *et al.* (2010). "Artemisinin directly targets malarial mitochondria through its specific mitochondrial activation." PLoS One **5**(3): e9582.
- Warhurst, D. C. (1984). "Why are primaquine and other 8-aminoquinolines particularly effective against the mature gametocytes and the hypnozoites of malaria?" Ann Trop Med Parasitol **78**(2): 165.
- Warhurst, D. C. (1986). "Antimalarial drugs: mode of action and resistance." J Antimicrob Chemother **18 Suppl B**: 51-59.
- Warhurst, D. C., J. C. Craig, *et al.* (2002). "Lysosomes and drug resistance in malaria." Lancet **360**(9345): 1527-1529.
- Warhurst, D. C., J. C. Craig, *et al.* (2007). "Activity of piperaquine and other 4-aminoquinoline antiplasmodial drugs against chloroquine-sensitive and resistant blood-stages of Plasmodium falciparum. Role of beta-haematin inhibition and drug concentration in vacuolar water- and lipid-phases." Biochem Pharmacol **73**(12): 1910-1926.

- Wellems, T. E., A. Walker-Jonah, *et al.* (1991). "Genetic mapping of the chloroquine-resistance locus on *Plasmodium falciparum* chromosome 7." Proc Natl Acad Sci U S A **88**(8): 3382-3386.
- Wernsdorfer, W. H. (1991). "The development and spread of drug-resistant malaria." Parasitol Today **7**(11): 297-303.
- Wernsdorfer, W. H. and H. Noedl (2003). "Molecular markers for drug resistance in malaria: use in treatment, diagnosis and epidemiology." Curr Opin Infect Dis **16**(6): 553-558.
- White, N. (1999). "Antimalarial drug resistance and combination chemotherapy." Philos Trans R Soc Lond B Biol Sci **354**(1384): 739-749.
- White, N. J. (1992). "Antimalarial drug resistance: the pace quickens." J Antimicrob Chemother **30**(5): 571-585.
- White, N. J. (1997). "Assessment of the pharmacodynamic properties of antimalarial drugs in vivo." Antimicrob Agents Chemother **41**(7): 1413-1422.
- White, N. J. (1998a). "Drug resistance in malaria." Br Med Bull **54**(3): 703-715.
- White, N. J. (1998b). "Preventing antimalarial drug resistance through combinations." Drug Resist Updat **1**(1): 3-9.
- White, N. J. (2004). "Antimalarial drug resistance." J Clin Invest **113**(8): 1084-1092.
- White, N. J. (2008). "Qinghaosu (artemisinin): the price of success." Science **320**(5874): 330-334.
- White, N. J., P. Chanthavanich, *et al.* (1983). "Quinine disposition kinetics." Br J Clin Pharmacol **16**(4): 399-403.
- White, N. J., F. Nosten, *et al.* (1999). "Averting a malaria disaster." Lancet **353**(9168): 1965-1967.
- White, N. J. and W. Pongtavornpinyo (2003). "The de novo selection of drug-resistant malaria parasites." Proc Biol Sci **270**(1514): 545-554.
- WHO (1986). Chemotherapy of Malaria. L. J. Bruce-Chwatt. Geneva, World Health Organization.
- WHO (1998). The use of artemisinin and its derivatives as anti-malarial drugs. Geneva, World Health Organization.
- WHO (2001a). Antimalarial Drug Combination Therapy, World Health Organization.
- WHO (2001b). *In vitro* micro-test (Mark III) for the assessment of the response of *Plasmodium falciparum* to chloroquine, mefloquine, quinine, amodiaquine, sulfadoxine/pyrimethamine and artemisinin. Geneva, World Health Organization.
- WHO (2001c). The use of antimalarial drugs - Report of an Informal Consultation. Geneva, World Health Organization.
- WHO (2001d). WHO Policy recommendation on Intermittent Preventive Treatment during infancy with sulphadoxine-pyrimethamine (SP-IPTi) for *Plasmodium falciparum* malaria control in Africa. Geneva, World Health Organization.
- WHO (2003). Assessment and Monitoring of Antimalarial Drug Efficacy for the Treatment of Uncomplicated Falciparum Malaria, World Health Organization.
- WHO (2006). Indoor residual spraying - Use of indoor residual spraying for scaling up global malaria control and elimination, World Health Organization.
- WHO (2007). Long-lasting insecticidal nets for malaria prevention. A manual for malaria programme managers, World Health Organization.
- WHO (2008). Global malaria control and elimination : report of a technical review., World Health Organization.
- WHO (2010a). Global report on antimalarial drug efficacy and drug resistance: 2000-2010. Geneva, World Health Organization.
- WHO (2010b). Guidelines for the treatment of malaria - Second edition. Geneva, World Health Organization.

- WHO (2011a). Global plan for artemisinin resistance containment (GPARC). Geneva, World Health Organization.
- WHO (2011b). World Malaria Report: 2011, World Health Organization (WHO).
- WHO (2012a). Single dose Primaquine as a gametocytocide in Plasmodium falciparum malaria (Updated WHO Policy Recommendation). Geneva, World Health Organization.
- WHO (2012b). World malaria report : 2012., World Health Organization.
- WHO (2013a). Emergency response to artemisinin resistance in the Greater Mekong subregion: regional framework for action 2013-2015. Geneva.
- WHO (2013b). Indoor Residual Spraying - An operational manual for indoor residual spraying (IRS) for malaria transmission control and elimination. Geneva, World Health Organization.
- WHO. (2013c, Dec 2013). "Malaria- Fact sheet N°94 ", 2014, from <http://www.who.int/mediacentre/factsheets/fs094/en/>.
- WHO (2013d). Seasonal Malaria Chemoprevention with sulfadoxine–pyrimethamine plus amodiaquine in children. Geneva, World Health Organization.
- WHO (2013e). WHO Policy Brief for the Implementation of Intermittent Preventive Treatment of Malaria in Pregnancy using Sulfadoxine-Pyrimethamine (IPTp-SP). Geneva, World Health Organization.
- WHO (2013f). World Malaria Report, World Health Organization.
- WHO (2014). Status report on artemisinin resistance. Geneva, World Health Organization.
- Witkowski, B., C. Amaratunga, *et al.* (2013). "Novel phenotypic assays for the detection of artemisinin-resistant Plasmodium falciparum malaria in Cambodia: in-vitro and ex-vivo drug-response studies." *Lancet Infect Dis* **13**(12): 1043-1049.
- Witmer, K., C. D. Schmid, *et al.* (2012). "Analysis of subtelomeric virulence gene families in Plasmodium falciparum by comparative transcriptional profiling." *Mol Microbiol* **84**(2): 243-259.
- Wongsrichanalai, C., A. L. Pickard, *et al.* (2002). "Epidemiology of drug-resistant malaria." *Lancet Infect Dis* **2**(4): 209-218.
- Wongsrichanalai, C., J. Sirichaisinthop, *et al.* (2001). "Drug resistant malaria on the Thai-Myanmar and Thai-Cambodian borders." *Southeast Asian J Trop Med Public Health* **32**(1): 41-49.
- Woodrow, C. J., R. K. Haynes, *et al.* (2005). "Artemisinins." *Postgrad Med J* **81**(952): 71-78.
- Wu, W. M., Y. L. Chen, *et al.* (2003). "Study on the mechanism of action of artemether against schistosomes: the identification of cysteine adducts of both carbon-centred free radicals derived from artemether." *Bioorg Med Chem Lett* **13**(10): 1645-1647.
- Yang, H. L., D. Q. Liu, *et al.* (1997). "In vitro sensitivity of Plasmodium falciparum to eight antimalarials in China-Myanmar and China-Lao PDR border areas." *Southeast Asian J Trop Med Public Health* **28**(3): 460-464.
- Zani, B., M. Gathu, *et al.* (2014). "Dihydroartemisinin-piperaquine for treating uncomplicated Plasmodium falciparum malaria." *Cochrane Database Syst Rev* **1**: CD010927.
- Zhang, Z., J. Y. Wu, *et al.* (2004). "Regulation of the stability of P-glycoprotein by ubiquitination." *Mol Pharmacol* **66**(3): 395-403.
- Zheng, X. Y., C. Chen, *et al.* (1982). "[Synthesis of new antimalarial drug pyronaridine and its analogues (author's transl)]." *Yao Xue Xue Bao* **17**(2): 118-125.
- Zheng, X. Y., Y. Xia, *et al.* (1979). "[Synthesis of 7351, a new antimalarial drug (author's transl)]." *Yao Xue Xue Bao* **14**(12): 736-737.
- Zwang, J., G. Dorsey, *et al.* (2014). "Plasmodium falciparum clearance in clinical studies of artesunate-amodiaquine and comparator treatments in sub-Saharan Africa, 1999-2009." *Malar J* **13**: 114.

