

LONDON  
SCHOOL of  
HYGIENE  
& TROPICAL  
MEDICINE



**The characterization of the lipoprotein VacJ in *Burkholderia pseudomallei* and *Burkholderia thailandensis***

**JIALI LIM**

**Thesis submitted in accordance with the requirements for  
the degree of**

**Doctor of Philosophy of the**

**University of London**

**SEPTEMBER 2014**

**Department of Pathogen Molecular Biology**

**Faculty of Infectious and Tropical Diseases**

**LONDON SCHOOL OF HYGIENE & TROPICAL MEDICINE**

Scholarship funded by DSO National Laboratories, Singapore

## Declaration

I, Jiali Lim, confirm that the work presented in this thesis is my own. Where information has been derived from other sources, I confirm that this has been indicated in the thesis. All experiments were carried out at the London School of Hygiene and Tropical Medicine (LSHTM).

Dr. Jon Cuccui provided the *Burkholderia pseudomallei* strains K96243, 13H8, and *Burkholderia thailandensis* E264. Dr. Jo Stevens provided the plasmid pME6032. All animal studies were carried out with assistance from Dr. Natasha Spink, Dr. Madeleine Moule and Dr. Beak San Choi.

23/1/2015

A handwritten signature in black ink, appearing to be 'Jiali Lim', written over a horizontal line.

Jiali Lim

Signed by: Lim Jiali

## Abstract

*Burkholderia pseudomallei*, the causative agent of melioidosis, has evolved multiple strategies to facilitate survival in the environment and can cause serious disease in the human host. The lipoprotein BPSL3147 (VacJ) was previously shown to be important in the growth and survival of *B. pseudomallei* in an *in vivo* mouse model and a VacJ transposon mutant was highly attenuated. This work has focused on elucidating the role of VacJ as a virulence determinant in *B. pseudomallei*. The gene was characterized using bioinformatic and genetic techniques, utilizing comparisons with *B. thailandensis* to study the *in vivo* and *in vitro* roles. In this study a rationally defined *B. pseudomallei* VacJ deletion mutant was constructed, verified and evaluated. The VacJ mutant was able to colonize mice organs during the initial infection phase, but was unable to sustain the infection. In *in vitro* assays the VacJ mutant did not display any defect in early steps of the intracellular lifecycle. However, VacJ appears to play a contributory role to human serum resistance, as evidenced by the serum susceptibility of an acapsular *B. pseudomallei* BPSL3147 mutant and *B. thailandensis* VacJ mutants. Taken together, VacJ contributes to virulence by affecting the outer membrane of *B. pseudomallei* and *B. thailandensis* affecting serum resistance sensitivity. The *B. pseudomallei* VacJ mutant was also investigated for potential as a live attenuated vaccine and displayed partial protection against a lethal challenge in an acute intranasal mice infection model.

## Contents

Declaration .....	2
Abstract .....	3
List of Figures .....	7
List of Tables .....	9
Publications .....	10
Acknowledgements.....	11
Abbreviations.....	12
1. Chapter 1 – Introduction .....	15
1.1 The <i>Burkholderia</i> genus .....	15
1.1.1 <i>Burkholderia pseudomallei</i> .....	17
1.1.2 <i>Burkholderia mallei</i> .....	20
1.1.3 <i>Burkholderia thailandensis</i> .....	21
1.2 Melioidosis, the disease and risk factors .....	22
1.3 Geographical distribution and epidemiology .....	24
1.4 Diagnosis and treatment.....	27
1.5 Antimicrobial Drug resistance .....	30
1.6 Modes of persistence – environmental and clinical lifestyles .....	32
1.7 Methods used for the identification of virulence factors .....	34
1.8 Selected virulence factors .....	35
1.8.1 Surface polysaccharides: Capsule and lipopolysaccharides .....	36
1.8.2 Secretion systems.....	41
1.8.3 BimA motility .....	44
1.8.4 Flagella and pili.....	45
1.9 Bacterial lipoproteins .....	47
1.10 VacJ/MlaA family lipoproteins.....	52
1.11 Project aims .....	53
2. Chapter 2 – Materials and Methods .....	54
2.1 Chemicals and Reagents .....	54
2.2 Biosafety containment level 3 safety protocols.....	54
2.3 Bacteria and Cell lines.....	55
2.3.1 Bacterial strains and culture conditions .....	55
2.3.2 Cell lines and culture conditions.....	59
2.4 Bioinformatics tools .....	59
2.5 Molecular Biology .....	60

2.5.1 DNA extraction and purification.....	60
2.5.2 Oligonucleotide primers.....	60
2.5.3 Polymerase chain reaction (PCR).....	65
2.5.4 Agarose gel electrophoresis.....	66
2.5.5 Restriction enzyme digest .....	67
2.5.6 Dephosphorylation of vector DNA .....	67
2.5.7 Ligation .....	67
2.5.8 Preparing electrocompetent <i>E. coli</i> cells.....	68
2.5.9 Preparing electrocompetent <i>B. thailandensis</i> cells.....	68
2.5.10 Electroporation transformation.....	69
2.5.11 Nucleotide sequencing .....	69
2.5.12 RNA extraction .....	70
2.5.13 Reverse transcription PCR .....	70
2.5.14 Sodium dodecyl sulphate polyacrylamide gel electrophoresis (SDS-PAGE) 71	
2.5.15 Polyacrylamide protein gel staining .....	71
2.5.16 Western blot.....	71
2.6 Mutant construction and characterization .....	72
2.6.1 Cloning .....	72
2.6.2 Conjugation.....	73
2.6.3 Sucrose selection .....	74
2.6.4 Complementation .....	74
2.7 <i>In vitro</i> assays .....	74
2.7.1 Growth curves.....	74
2.7.2 Antimicrobial sensitivity assay .....	75
2.7.3 Growth inhibition assays in SDS or EDTA .....	75
2.7.4 Adhesion assay .....	76
2.7.5 Intracellular survival assay.....	76
2.7.6 Immunofluorescence.....	77
2.7.7 Giemsa staining of MNGCs.....	78
2.8 <i>In vivo</i> studies .....	78
2.8.1 Mice infection model .....	79
2.8.2 Protection studies .....	80
2.9 Statistical Analysis.....	80
3. Chapter 3 – Identification and characterization of <i>B. pseudomallei</i> VacJ .....	81
3.1 Introduction .....	81

3.2 Aims .....	86
3.3 Results .....	86
3.3.1 Bioinformatic analysis of <i>bpsI3147</i> .....	86
3.3.2 Predicted roles of VacJ .....	91
3.4 Discussion.....	94
4. Chapter 4 - Characterizing the role of VacJ in <i>B. pseudomallei</i> .....	96
4.1 Introduction .....	96
4.2 Aims: .....	97
4.3 Results .....	97
4.3.1 Unmarked in-frame deletion mutagenesis of <i>bpsI3147</i> in <i>B. pseudomallei</i> .....	97
4.3.2 Growth in media.....	104
4.3.3 Virulence of <i>B. pseudomallei</i> BPSL3147 mutants <i>in vivo</i> .....	105
4.3.4 Infection of mammalian cell lines .....	108
4.3.5 Serum Survival .....	112
4.3.6 Growth inhibition assays .....	114
4.3.7 Detection of LPS in <i>B. pseudomallei</i> BPSL3147 .....	116
4.3.8 Protective effects by infection with <i>B. pseudomallei</i> BPSL3147 in BALB/c mice .....	117
4.4 Discussion.....	119
5. Chapter 5 Characterization of VacJ in <i>Burkholderia thailandensis</i> .....	128
5.1 Introduction .....	128
5.2 Aims: .....	129
5.3 Results .....	129
5.3.1 Deletion of <i>Burkholderia thailandensis</i> putative VacJ homologues.....	129
5.3.2 Mutant production .....	130
5.3.3 Complementation of mutant strain .....	133
5.3.4 Growth in media.....	134
5.3.5 Serum survival .....	135
5.3.6 Infection of mammalian cell lines .....	138
5.4 Discussion.....	149
Chapter 6 – General Discussion and Future Work.....	154
Chapter 7 - Bibliography .....	162
A. Appendices.....	183
Appendix 1 .....	183
Appendix 2 .....	184

## List of Figures

Figure 1.1. Phylogenetic relationships among some <i>Burkholderia</i> species. ....	16
Figure 1.2. The worldwide distribution of melioidosis. ....	26
Figure 1.3 Intracellular lifecycle of <i>B. pseudomallei</i> and <i>B. mallei</i> . ....	33
Figure 1.4 Summary of known bacterial secretion systems.....	41
Figure 1.5 Schematic of a typical lipoprotein sequence .....	48
Figure 1.6 Biosynthesis of bacterial lipoproteins. ....	49
Figure 3.1 Schematic representation of the original STM strategy .....	82
Figure 3.2 Amino acid sequence of BPSL3147 in <i>B. pseudomallei</i> K96243 contains a typical lipoprotein signal peptide sequence. ....	86
Figure 3.3 BLASTP alignment of VacJ protein sequences, showing percent amino acid identity between different strains. ....	89
Figure 3.4 Model of the Mla and PldA PL turnover pathways.....	93
Figure 3.5 Gene organization of the Mla transport system. ....	93
Figure 4.1 Cloning strategy to produce the deletion construct.....	100
Figure 4.2 Production of deletion mutant .....	101
Figure 4.3 Screening of <i>B. pseudomallei</i> deletion mutants.....	102
Figure 4.4 Confirmation of BPSL3147 mutant by sequencing and reverse transcription PCR (RT-PCR) analysis. ....	103
Figure 4.5 Growth curve of <i>B. pseudomallei</i> wild type or VacJ mutants in LB broth at 37°C. ....	104
Figure 4.6 Survival data of i.n. infection of BALB/c mice. ....	106
Figure 4.7 Differential susceptibility to colonization by <i>B. pseudomallei</i> mutant BPSL3147 in BALB/C mice. ....	107
Figure 4.8 Adherence or invasion of A549 epithelial cells by <i>B. pseudomallei</i> K96243 wild type or BPSL3147 strains.....	109
Figure 4.9 Intracellular replication of <i>B. pseudomallei</i> K96243 or BPSL3147 mutant strain in J774A.1 murine macrophage-like cells. ....	110
Figure 4.10 Multinucleated giant cell formation was observed in Giemsa-stained J774A.1 cells infected with (i) <i>B. pseudomallei</i> wild type or (ii) BPSL3147 mutant strain.....	111
Figure 4.11 Serum survival assay on <i>B. pseudomallei</i> . ....	114
Figure 4.12 Membrane stability of <i>B. pseudomallei</i> K96243 and mutant strains...	115
Figure 4.13 Western blot staining LPS from <i>B. pseudomallei</i> strains. ....	116
Figure 4.14 Protection assay of BALB/c mice vaccinated with <i>B. pseudomallei</i> VacJ mutants.....	118
Figure 5.1 Screening for <i>B. thailandensis</i> deletion mutant (E264 BTH_I3001)...	131
Figure 5.2 Sequence of the <i>B. thailandensis</i> E264 BTH_I3001 mutant surrounding the deleted region. ....	131
Figure 5.3 Screening for <i>B. thailandensis</i> deletion mutant (E264 BTH_II2351)...	132
Figure 5.4 Sequence of the <i>B. thailandensis</i> BTH_II2351 mutant surrounding the deleted region. ....	132

Figure 5.5 Growth curves of <i>B. thailandensis</i> wild type and VacJ mutants in LB broth at 37°C. ....	134
Figure 5.6 Serum survival assay for <i>B. thailandensis</i> . ....	137
Figure 5.7 Intracellular replication of <i>B. thailandensis</i> E264 wild type or the BTH_I3001 mutant strain in J774A.1 macrophages. ....	140
Figure 5.8 Adherence of A549 epithelial cells by <i>B. thailandensis</i> wild type or VacJ mutants ( BTH_I3001 and DB). ....	141
Figure 5.9 Association of intracellular <i>B. thailandensis</i> with LAMP-1. ....	145
Figure 5.10 Association of intracellular <i>B. thailandensis</i> with autophagy marker LC3b. ....	146
Figure 5.11 Association of <i>B. thailandensis</i> with F-actin. ....	147
Figure 5.12 MNGC formation in J774A.1 murine macrophages. ....	148
Figure A.1 Plasmid map of pMEK. ....	184
Figure A.2 pMEK DNA sequence. ....	187



## List of Tables

Table 2.1 Growth media used in this study .....	56
Table 2.2 List of strains used in this study.....	57
Table 2.3 List of plasmids used in this study.....	58
Table 2.4 Oligonucleotide primers used for the construction of unmarked in-frame <i>B. pseudomallei</i> and <i>B. thailandensis</i> mutants. ....	61
Table 2.5 PCR primers for screening deletion mutant ( <i>B. pseudomallei</i> ) .....	62
Table 2.6 PCR Primers for screening deletion mutant ( <i>B. thailandensis</i> ) .....	63
Table 2.7 Other sequencing primers used in this study.....	64
Table 2.8 Oligonucleotide primers used in making complementation construct for <i>B. thailandensis</i> .....	65
Table 3.1 Selected examples of a retrospective TraDIS investigation of STM mutants.....	85
Table 3.2 Family of VacJ orthologues .....	90
Table 5.1 Minimal inhibitory concentration (MIC) of antibiotics on <i>B. thailandensis</i> .....	138
Table A.1 Solutions used in this study .....	182
Table A.2 Primers used in replacement of antibiotic cassette in pME6032 .....	183
Table A.3 Features of pMEK.....	188

## **Publications**

### **Paper:**

**Genome-wide saturation mutagenesis of *Burkholderia pseudomallei* K96243 predicts essential genes and novel targets for antimicrobial development** – Moule M.G., Hemsley C.M., Seet Q., Guerra-Assunção J.A., Lim J., Sarkar-Tyson M., Clark T.G., Tan P., Titball, R.W., Cuccui J. and Wren B.W. mBio, 2014 5(1) e00926-13.

### **Posters:**

**Elucidating the role of putative lipoprotein VacJ in *Burkholderia pseudomallei* and *Burkholderia thailandensis*** – Lim J., Moule M.G., Cuccui J., Wren B.W. Presented at the 7th World Melioidosis Congress, 2013 – awarded poster prize.

**Elucidating the role of putative lipoprotein VacJ in *Burkholderia pseudomallei* and *Burkholderia thailandensis*** – Lim J., Moule M.G., Cuccui J., Wren B.W. Presented at the Autumn SGM, 2013

## **Acknowledgements**

Firstly, I would like to express my sincere gratitude to my supervisors Professor Brendan Wren and Dr. Madeleine Moule for their patience, motivation, guidance, and mentorship throughout my PhD. Their continuous support and enthusiasm has inspired me greatly in this subject. I must also thank Dr. Jon Cuccui, who is always there to answer my countless questions, and to provide training, guidance and reviews.

Special thanks to: Dr. Gregory Bancroft for his input on animal study design, Dr. Natasha Spink and Dr. Beak San Choi for helping with the animal infections; Dr. Carmen Denman, Dr. Petra Oyston, Dr. Nick Dorrell and Dr. Richard Stabler, for providing invaluable reviews and perspectives on the organism; Dr. Elizabeth McCarthy, Rachel Gregory and Priyanka Narang for the microscopy training; Dr. Sam Willcocks, Dr. Laura Conejero, Felipe Cia, Heidi Alderton for the help in the Cat3 lab; my brilliant labmates, Elizabeth Donahue, Dr. Ozan Gundogdu, Dr. Vanessa Terra, Dr. Abdi Elmi, Dr. Alexandra Faulds-Pain, Michelle Cairns, Neveda Naz, Dr. Laura Yates and Dr. Dominic Mills; Dr. Jo Stevens, for providing the complementation vector; DSO National Laboratories for the funding and support; and to anyone else who has helped out with trainings, ideas or discussions!

Massive thanks to all of my friends, especially Ben, Cat, Yvonne, Hwee Teng, Ting, Bekah, David, Christian, Sophie, Kerstin and Laura for the philosophical discussions and encouragements.

Finally, I want to thank my family and Alf, for being so patient, and for always standing by me.

## Abbreviations

%	Percent
	Delta
°C	Degrees celsius
	Alpha
ABC	ATP binding cassette
ACDP	Advisory committee on dangerous pathogens
Amp	Ampicillin
ANOVA	Analysis of variance
ATCC	American type culture collection
	Beta
BLAST	Basic local alignment search tool
bp	Base pair
BSA	Bovine serum albumin
Bsa	<i>Burkholderia</i> secretion apparatus
CFU	Colony forming unit
CPS	Capsular polysaccharide
DAP	Diaminopimelic acid
DAPI	4', 6-Diamidino-2-phenylindole, dihydrochloride
DMEM	Dulbecco's Modified Eagle Medium
DMSO	Dimethyl sulphoxide
DNA	Deoxyribonucleic acid
dNTPs	Deoxyribonucleotide triphosphates
DPX	dibutyl phthalate xylene
EDTA	Ethylenediaminetetra acetic acid
ELISA	Enzyme linked immunosorbent assay
FCS	Foetal calf serum
g	Grams
	Gamma
GI	Genomic island
h	Hour
HCl	Hydrochloric acid
Hi-NHS	Heat inactivated normal human serum
IFN	Interferon
IgG	Immunoglobulin G
i.n.	intranasal
i.p.	intraperitoneal
IPTG	Isopropyl -D-1-thiogalactopyranoside
IS	insertion sequence
IVET	<i>In vivo</i> expression technology
Km	Kanamycin
Kb	Kilo base
kDa	Kilo dalton
L	Litre

LB	Luria-Bertani
LF	Left flank
LPS	Lipopolysaccharide
μ	Micro
m	Milli
M	Molar
MAb	Monoclonal antibody
Mb	Mega base
MIC	Minimum inhibitory concentration
min	Minute (s)
MLD	Median lethal dose
MNGC	Multinucleated giant cells
MOI	Multiplicity of infection
MW	Molecular weight
n	Nano
NaCl	Sodium chloride
NCBI	National Center for Biotechnology Information
NHS	Normal human serum
OD	Optical density
OMPs	Outer membrane proteins
O-PS	O-polysaccharide
ORF	Open reading frame
p	Probability / pico
PAGE	Polyacrylamide gel electrophoresis
PBS	Phosphate buffered saline
PBST	Phosphate buffered saline (+Tween)
PCR	Polymerase chain reaction
pH	Potential of hydrogen
p.i.	Post infection
R	Resistant
RF	Right flank
rRNA	Ribosomal ribonucleic acid
S	Second (s)
SOC	Super optimal catabolite
SDS	Sodium dodecyl sulphate
STM	Signature tagged mutagenesis
TAE	Tris-acetate-EDTA
Tn	Transposon
T3SS	Type 3 secretion system
T6SS	Type 6 secretion system
TLR	Toll-like receptor
TNF	Tumour necrosis factor
TraDIS	Transposon-directed insertion-site sequencing
U	Unit
UK	United Kingdom
UV	Ultraviolet

V	Volt
Vol	Volume
Zeo	Zeocin
WT	Wild type
x g	Centrifugal force

# 1. Chapter 1 – Introduction

## 1.1 The *Burkholderia* genus

The *Burkholderiaceae* family lies within the  $\alpha$ -Proteobacteria class and is comprised of members from several genera including *Burkholderia* and *Ralstonia* (Garrity, 2005). The *Burkholderia* genus is comprised of more than 60 species (Estrada-de los Santos et al., 2013) which can occupy a wide range of ecological niches including soil, water, plant roots, amoebae and animals (Inglis et al., 2000, Coenye et al., 2003, Sprague and Neubauer, 2004, Compant et al., 2008, Khan et al., 2013). There are two sub-lineages within the *Burkholderia* genus based on 16S rRNA sequence and multilocus sequence analyses (MLSA) (Brett et al., 1998, Estrada-de los Santos et al., 2013). One of these sub-lineages comprises soil, water and plant-associated species (group A); and the other sub-lineage contains several *Burkholderia* species that are known to be pathogenic in humans, along with some environmental and plant pathogenic species (group B, Figure 1.1) (Estrada-de los Santos et al., 2013). Among the pathogenic *Burkholderia*, *Burkholderia pseudomallei*, the causative agent of melioidosis, and *Burkholderia mallei*, the causative agent of glanders, are important because of the potentially life-threatening clinical features of these diseases. The *Burkholderia cepacia* complex bacteria are another medically important group of opportunistic pathogens that primarily affect patients with cystic fibrosis. Amongst the many diverse species classified within the *Burkholderia* genus, *B. pseudomallei* is found to be most closely related to the equine-associated obligate pathogen *B. mallei* and the avirulent environmental

saprophyte *Burkholderia thailandensis* based on 16S rRNA similarity and MLSA (Brett et al., 1998, Estrada-de los Santos et al., 2013).

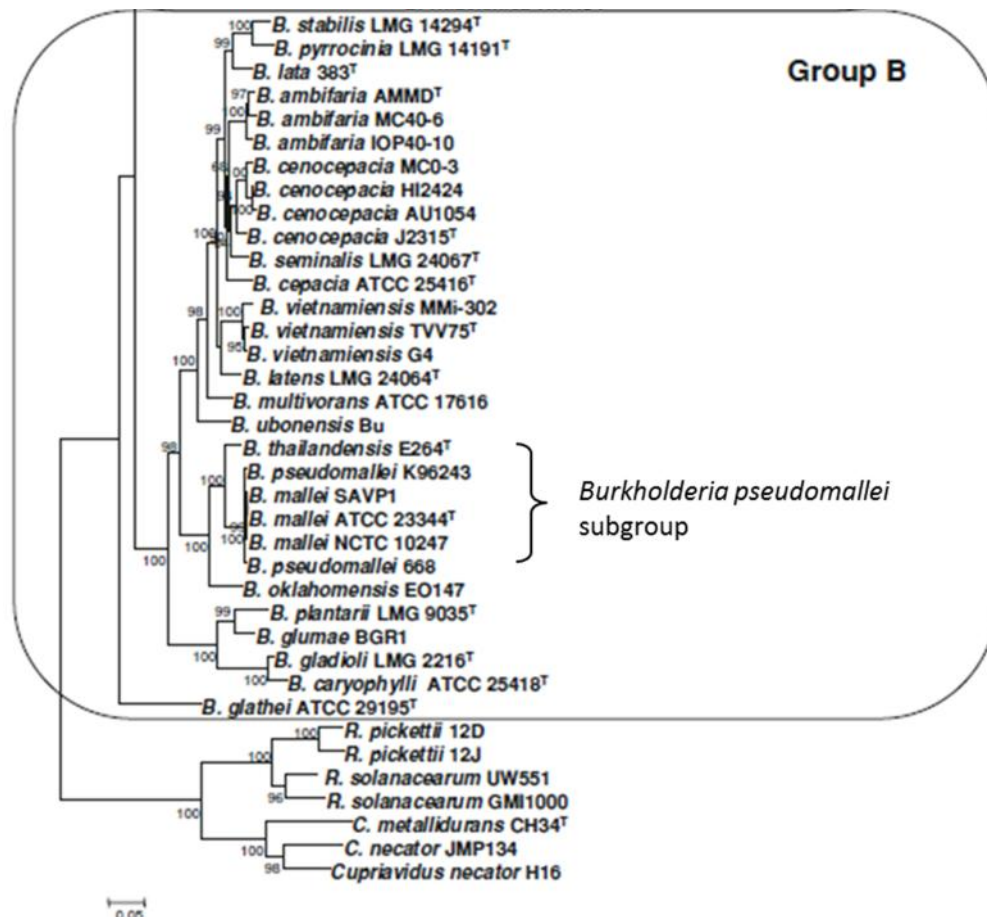

**Figure 1.1. Phylogenetic relationships among some *Burkholderia* species.**

The maximum likelihood tree inferred from the concatenated alignment of *atpD-gltB-lepA-recA-16S* rRNA genes shows the phylogenetic relationships among some *Burkholderia* species. (Adapted from (Estrada-de los Santos et al., 2013)).



### 1.1.1 *Burkholderia pseudomallei*

*B. pseudomallei* is a Gram-negative, rod-shaped bacillus with rounded ends which ranges from 0.5 - 1 x 1.5 - 4 µm in dimension and occurs as single or paired cells (Garrity, 2005). It is an environmental saprophyte found in rice paddies, stagnant waters and moist tropical soils. Optimal growth conditions for this bacterium include aerobic conditions, 37°C growth temperature and a pH of 6.5 to 7.5. It can also survive as a facultative intracellular pathogen and is associated with disease in a range of hosts including human, mammals, birds, reptiles and amoeba (Inglis et al., 2000). It is a metabolically versatile organism and can utilize a wide variety of organic compounds as sources of carbon and energy for growth. It can undergo morphology switching and display up to seven major colony morphotypes in response to environmental stress (Chen et al., 2003a, Chantratita et al., 2007a, Tandhavanant et al., 2010). It is intrinsically resistant to many antibiotics and there is no licensed vaccine available (Cheng and Currie, 2005b).

*B. pseudomallei* has a large, complex genome for a bacterium of approximately 7.04 - 7.25 Mb comprised of two chromosomes with an overall G+C content of 68 %. Computational analysis of protein coding genes in the first sequenced strain of *B. pseudomallei*, strain K96243, predicted 5737 coding sequences (Holden et al., 2004, Winsor et al., 2008, Nandi and Tan, 2012). Chromosome 1 (4.07 Mb) contains a relatively high proportion of genes involved in core housekeeping functions, while chromosome 2 (3.17 Mb) contains a high proportion of accessory genes associated with environmental adaptation (Holden et al., 2004, Sim et al., 2008). Comparative analysis of multiple *B. pseudomallei* genomes revealed that the

core- and pan-genome consists of 4909 and 7500 predicted coding sequences respectively, with a significant amount of genetic variation between strains (Nandi et al., 2010, Losada et al., 2010). *B. pseudomallei* appears to have acquired several strain specific genomic islands (GIs), including pathogenicity islands and prophages through horizontal gene transfer events (Tuanyok et al., 2007, Ronning et al., 2010). These GIs exhibit striking deviations in sequence composition (GC content, dinucleotide composition) from the general genome backbone. Twelve GIs were identified on chromosome 1, and four were identified on chromosome 2 (Holden et al., 2004). *B. pseudomallei* also has a high number of tandem and simple sequence repeats (SSRs) (U'Ren et al., 2007), most of which occur within or close to genes encoding surface or secreted proteins that may directly interact with host factors during pathogenesis or with other environmental factors (Han et al., 2009). There is a significant amount of genomic variation amongst *B. pseudomallei* isolates including variability in GIs between different strains and the SSRs, and this may be related in part to the variability in disease outcome (Tuanyok et al., 2008, Tumapa et al., 2008).

The extensive *B. pseudomallei* genome encodes a large number of factors that likely contribute to its various niche preferences, biological phenotypes, broad host range and its ability to cause disease. For example, *B. pseudomallei* K96243 has at least 10 operons that can code for components of resistance-nodulation-cell-division (RND) efflux pumps, which are recognized as major causes of multi-drug resistance in Gram-negative bacteria. Expression of these RND pumps can be induced by exposure to toxic compounds (Kumar et al., 2008a). The genome also has several

clusters of secondary metabolite genes that may produce metabolites, lipopeptides and siderophores to promote survival in soil against competing microorganisms. The *B. pseudomallei* genome encodes many virulence factors such as several type IV pili (TFP) and fimbrial clusters (Holden et al., 2004, Essex-Lopresti et al., 2005), a number of type III secretion systems (T3SS) and type VI secretion systems (T6SS), surface carbohydrates such as the capsular polysaccharide (CPS) and lipopolysaccharide (LPS). A more detailed presentation of these *B. pseudomallei* virulence factors is provided in Section 1.8.

### 1.1.2 *Burkholderia mallei*

*B. mallei*, the causative agent of glanders, carries many genotypic and phenotypic similarities to *B. pseudomallei*, but is an obligate pathogen and cannot persist outside its mammalian hosts (horses and other solipeds) (reviewed in (Galyov et al., 2010)). It has a similar, but smaller genome of about 5.7 Mb (5.23 – 5.84 Mb) compared to *B. pseudomallei* and is considered to have evolved from an ancestral strain of *B. pseudomallei* (Godoy et al., 2003). While the majority of genes retained by *B. mallei* share 99 % DNA-DNA sequence identity with *B. pseudomallei*, a large number of insertion sequence (IS) elements are found in the *B. mallei* genome. These IS elements are thought to have mediated extensive genome-wide rearrangements that resulted in many pseudogenes compared to *B. pseudomallei*, and contribute to phenotypic and physiological differences (Nierman et al., 2004, Kim et al., 2005a). Many of the functional genes associated with environmental survival in *B. pseudomallei* are absent or disrupted in *B. mallei* (Losada et al., 2010). For example, in *B. mallei*, genes associated with flagellum biogenesis (*flip*) and the flagellum motor (*motB*) are disrupted by a 65-kb insert flanked by insertion elements and a frameshift mutation respectively, rendering it non-flagellated and non-motile (Nierman et al., 2004). Historically, *B. mallei* was used as a bioweapon during the World Wars I and II (Wheelis, 1998, Rotz et al., 2002, Whitlock et al., 2007), and is also classified as a Tier 1 select agent in the National Select Agent Registry (United States).

### 1.1.3 *Burkholderia thailandensis*

*B. thailandensis* is an environmental saprophyte that carries many phenotypic similarities to *B. pseudomallei* but is much less virulent (Wuthiekanun et al., 1996, Brett et al., 1998, DeShazer, 2007). To date, only four cases of human diseases caused by *B. thailandensis* have been reported, two in Southeast Asia (Dharakul et al., 1999, Lertpatanasuwun et al., 1999) and two in the Southeastern United States of America (Glass et al., 2006). *B. thailandensis* has a broadly similar genome (6.15 – 6.73 Mb) to *B. pseudomallei* and *B. mallei*, and has a number of orthologues of known virulence factors such as the type IV pili genes, *bsa* type 3 secretion system (T3SS-3), and five out of the six type 6 secretion systems (T6SS-1, -2, -3, -5, -6) (Yu et al., 2006). Similar to *B. pseudomallei*, *B. thailandensis* is resistant to many antibiotics, can infect cells, survive intracellularly, cause multinucleated giant cell formation, and can cause lethality in Syrian golden hamsters, BALB/c mice and C576 BL/6 mice, albeit at a much higher dose) (Brett et al., 1997, DeShazer, 2007, Schwarz et al., 2010) . Unlike *B. pseudomallei*, *B. thailandensis* contains a functional L-arabinose assimilation operon (which is largely deleted in *B. pseudomallei*) and xylose metabolism gene clusters and does not usually produce a capsular polysaccharide. The introduction of the full arabinose operon into genetically modified *B. pseudomallei* resulted in a downregulation of gene expression in T3SS genes, and a reduction of virulence when those strains were exposed to arabinose (Moore et al., 2004). The finding suggests that these arabinose assimilation genes may be considered antivirulence genes. As the capsule is an important virulence factor in *B. pseudomallei*, this was predicted to

correlate to the avirulence of *B. thailandensis*. However, a variant *B. thailandensis* isolate, E555, that has acquired the *B. pseudomallei* capsular polysaccharide biosynthesis gene cluster does not display enhanced virulence in murine infection assays (Sim et al., 2010), indicating that other virulence factors are also important in the *in vivo* infection model. Studies have linked the *bsa* T3SS and T6SS-5 to *B. thailandensis* virulence in a pneumonic murine infection model (Haraga et al., 2008, Schwarz et al., 2010).

## **1.2 Melioidosis, the disease and risk factors**

*B. pseudomallei* is the causative agent of melioidosis, a potentially fatal disease first described by Whitmore and Krishnaswami in 1911 in Burma (Whitmore and Krishnaswami, 1912). Melioidosis can infect humans (Whitmore and Krishnaswami, 1912, Stanton et al., 1924) and many species of animals (Lewis and Olds, 1952, O'Brien et al., 2003). Infection can occur following bacterial inoculation through the skin, ingestion, or inhalation (White, 2003, Limmathurotsakul et al., 2014). A wide variety of clinical symptoms may ensue, with manifestations ranging from low-grade chronic infection to acute septicaemia. Inhalation of *B. pseudomallei* is associated with a more severe disease presentation and can lead to pneumonia and septic shock. The bacteria may also be disseminated to distant sites, causing concomitant pneumonia and abscesses in multiple organs, including the liver and spleen, bone, skin, prostate, and brain stem tissue (Puthucheary et al., 1992, Currie et al., 2000b, White, 2003, Kumar et al., 2008b). Disseminated pneumonia is

present in 50 % of acute cases and is often associated with high mortality (Currie et al., 2000b). Melioidosis is difficult to treat, and the disease may relapse even with extensive antibiotics treatment (Currie et al., 2000b, Limmathurotsakul et al., 2006, Limmathurotsakul and Peacock, 2011). Upon resolution of the acute phase, chronic melioidosis can occur in which symptoms persist for many months, even years. Chronic melioidosis is found in < 15 % of cases (Currie et al., 2000a), where subacute presentations similar to tuberculosis are described.

Risk factors for disease progression include underlying conditions such as diabetes mellitus, chronic renal disease and chronic lung disease, immunosuppression and excessive alcohol consumption (Currie et al., 2004, Leelarasamee and Bovornkitti, 1989, Suputtamongkol et al., 1999). In addition, the risk of acquiring the disease may increase in people with occupational or recreational exposure to moist soil or surface water (e.g. rice farmers, agricultural workers, construction labourers, adventure travellers, military personnel and a variety of indigenous groups) (Cheng and Currie, 2005a).

Asymptomatic chronic infections may sometimes develop into a more acute form of infection after a period of latency, with one case documenting reactivation 62 years after the initial exposure (Ngauy et al., 2005). The disease may relapse even with extensive antibiotic treatment. The risk of relapse is associated with the choice and duration of oral antimicrobial therapy (Currie et al., 2000a, Limmathurotsakul et al., 2006, Limmathurotsakul and Peacock, 2011).

Currently, there is no licensed human vaccine for protection against melioidosis. Due to its potential to pose a severe threat to human health, *B. pseudomallei* is classified as a biosafety level 3 pathogen and is listed as a Tier 1 select agent and potential bioterrorism threat by the U.S. Centers for Disease Control and Prevention (CDC) and the Animal and Plant Health Inspection Service (APHIS).

### **1.3 Geographical distribution and epidemiology**

Melioidosis is endemic in Southeast Asia and Northern Australia, with sporadic cases reported in other tropical regions (Currie et al., 2008, Dance, 2000, Le Hello et al., 2005). *B. pseudomallei*, can be found in the environment in endemic regions, particularly in rice fields in Northeast Thailand (Wuthiekanun et al., 2009, Limmathurotsakul et al., 2010b), Laos (Rattanavong et al., 2011) and in soil and water samples in Northern Australia (Brook et al., 1997) (Figure 1.2). A review by the Detection of Environmental *B. pseudomallei* Working Party (DEBWorP) showed 'definite' evidence for the presence of environmental *B. pseudomallei* in 17 countries (Figure 1.2) (Limmathurotsakul et al., 2013). Clinical and environmental isolates of *B. pseudomallei* demonstrate virulence in animal models of infection (Brett et al., 1997, Smith et al., 1997). *B. thailandensis*, previously classified as *B. pseudomallei*-like strains with the ability to assimilate L-arabinose (Ara+) but with attenuated virulence in animal models, was first discovered in the environment of endemic areas in Northeast and central Thailand (Wuthiekanun et al., 1996). A subsequent phylogenetic study



classified these Ara+ isolates as *B. thailandensis* (Brett et al., 1998). *B. thailandensis* can also be found in Northern Australia (Levy et al., 2008).

The incidence of melioidosis is closely correlated with rainy seasons (Suputtamongkol et al., 1994, Cheng et al., 2008a). Each year, about 3000 to 4000 cases of clinical melioidosis are estimated to occur throughout Thailand (Wongratanacheewin and Sirisinha, 2012). The highest number of melioidosis cases is reported in Northeast Thailand, where it accounts for 20 % of all community-acquired septicaemias, with a mortality rate of 40 % in patients who receive treatment (Chaowagul et al., 1989, White, 2003). In Northern Australia, the overall mortality rate of culture-positive patients is about 20 – 25 % (Currie et al., 2000b, Malczewski et al., 2005, Cheng and Currie, 2005b).

In Northeast Thailand, approximately 80 % of the children develop antibodies to the bacteria by the age of four (Kanaphun et al., 1993, Cheng et al., 2008b). In one study, antibodies against the environmental *B. thailandensis* were found in a small percentage of patients with melioidosis in Thailand (Tiyawisutsri et al., 2005). In a separate study, Gilmore *et al.* (Gilmore et al., 2007) demonstrated that the sera from culture-positive patients in Northern Queensland will cross-react with *B. thailandensis*. There are relatively low rates of seropositivity (5 % – 12.8 %) within populations in Northern Australia compared to that recorded in Northeast Thailand or among immigrants from Southeast Asia to Queensland (29 %) (Ashdown and Guard, 1984, Currie et al., 2000b). Despite that, melioidosis remains the most common cause of severe community-acquired pneumonia in parts of Northern Australia (Currie et al., 2000b, Cheng and Currie, 2005b).

Melioidosis is considered to be an emerging disease, as it is being reported and recognised increasingly in many countries where it has not been previously described (Currie et al., 2008). These countries include China, Taiwan (Chen et al., 2010), Sri Lanka (Corea et al., 2012), Africa (Borgherini et al., 2006, Katangwe et al., 2013) and Columbia (Montufar et al., 2011). The apparent emergence is probably due to a combination of factors including better recognition and diagnostic ascertainment of the disease (Dance, 2000, Currie et al., 2008), increase in prevalence of conditions such as diabetes that enhance susceptibility to the disease (Antony et al., 2010), and climate change (Currie and Jacups, 2003, Chierakul et al., 2005, Cheng et al., 2006).

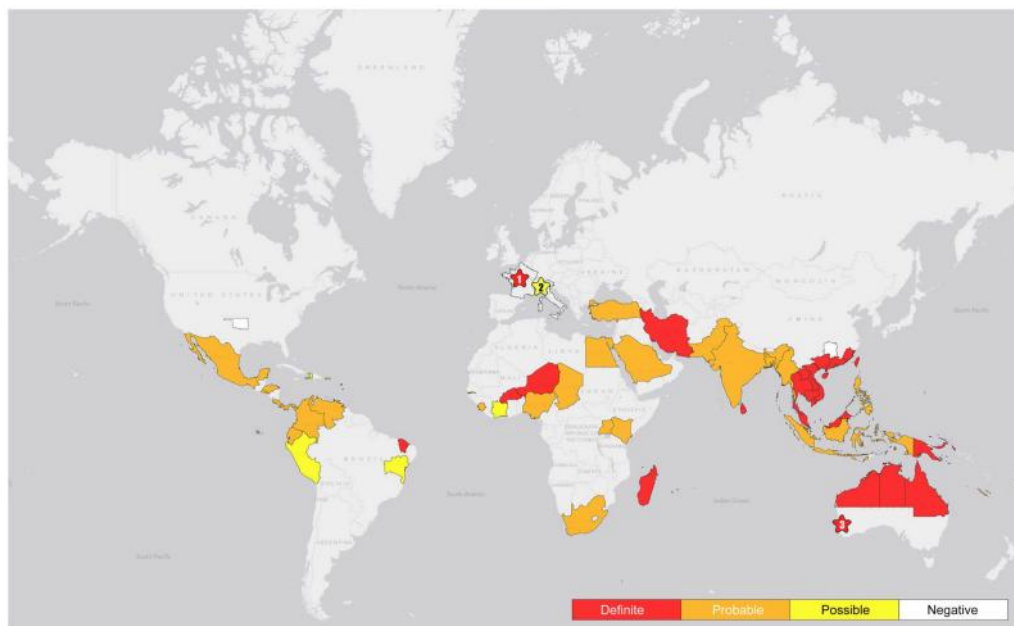

**Figure 1.2. The worldwide distribution of melioidosis.**

Stars indicated areas with reported outbreaks and/or presence of *B. pseudomallei* in temperate and subtropical regions in France, Italy, Australia and Southwest Australia (Reproduced from (Limmathurotsakul et al., 2013)).

## 1.4 Diagnosis and treatment

Timely diagnosis and identification of *B. pseudomallei* is critical to ensure optimal therapy. Microbiological culture remains the standard method for the diagnosis of melioidosis and treatment of melioidosis cases are currently based on definitive isolation of the organism on culture from blood, urine, sputum, pus or other clinical specimens (Lipsitz et al., 2012). *B. pseudomallei* grows well in most routine laboratory media but a selective medium such as Ashdown agar (Ashdown, 1979) or *Burkholderia cepacia* agar (Peacock et al., 2005) can aid in isolation of *B. pseudomallei* by suppressing overgrowth of normal microbiota in nonsterile specimens. Presumptive identification of *B. pseudomallei* involves simple bench tests in order to confirm an oxidase positive, Gram-negative bacillus, resistant to gentamicin and colistin, sensitive to amoxicillin-clavulanic acid, with a characteristic colonial morphology (reviewed in (Glass and Walsh, 2012)). Further definitive identification can be made using biochemical tests (API 20NE and Vitex II from bioMérieux Inc.), molecular detection or fatty acid profiling. Rapid diagnostic methods have been proposed, and include latex agglutination assays (Anuntagool et al., 2000) and polymerase chain reactions (PCR). A study performed by Wuthiekanun (Wuthiekanun et al., 2002) recommended using a latex agglutination assay that involves polyclonal and monoclonal antibodies against a 200 kDa exopolysaccharide for the confirmation of *B. pseudomallei* from blood culture specimens.

Serological diagnosis can support a clinical diagnosis or aid in identifying disease relapse by quantifying the human antibody response after exposure to *B. pseudomallei*. Common serological methods include the indirect

haemagglutination assay (IHA), the immunofluorescent antibody test (IFAT) and enzyme linked-immunosorbent assay (ELISA), which uses antigens derived from heat-killed bacteria, whole-killed organism, and a crude sonicated, protein extract respectively (Alexander et al., 1970, Ashdown et al., 1989). However the IHA may have limited role in serological diagnosis in endemic areas due to the presence of antibodies in apparently healthy individuals (Appassakij et al., 1990). Other serological methods using antibodies raised against cell wall components such as LPS, 30 kDa protein, exopolysaccharides (EPS) (Tiyawisutsri et al., 2005, Chantratita et al., 2007b), the outer membrane protein (OmpA) (Allwood et al., 2008) and truncated flagellin (Chen et al., 2003b), have limited efficiency since there is cross-reactivity with related *Burkholderia* species and may not provide better sensitivity and specificity.

A number of PCR diagnostic tests targeting bacterial genes such as the 16S rDNA, LPS, and T3SS1 clusters, have been developed for the direct detection of *B. pseudomallei* in clinical specimens and identification of isolates (Rattanathongkom et al., 1997, Haase et al., 1998, Meumann et al., 2006). These methods are rapid and specific, but require improvement in sensitivity for detection in clinical specimens (Kunakorn et al., 2000, Gal et al., 2005).

Treatment of severe melioidosis involves an initial intensive treatment phase (10-14 days) followed by a prolonged oral eradication phase (3-6 months) to reduce the risk of relapse. In general, the treatment involves the parenteral administration of ceftazidime or meropenem, with or without trimethoprim-sulfamethoxazole (TMP-SMX) (Lipsitz et al., 2012). With timely diagnosis,

institution of appropriate antibiotic therapy and access to state-of-the-art intensive care therapy, mortality in a patient without risk factors is unlikely (Currie et al., 2000a). However, in many locations where such treatment resources are limited, mortality from septicaemic melioidosis remains high (Chaowagul et al., 1989, Limmathurotsakul et al., 2006).

There has been on-going interest in the development of vaccines to protect against melioidosis, although there is yet no licensed human vaccine. In endemic areas, many apparent healthy individuals developed antibodies reactive to *B. pseudomallei* from a young age, suggesting some levels of protective immune responses may be present (Wuthiekanun et al., 2006). Yet, relapse of melioidosis in patients is common and prior exposure to the bacterium does not protect susceptible individuals from re-infection (Maharjan et al., 2005, Limmathurotsakul et al., 2006). The innate immune system appears to be critical for the initial containment of infection, but successful elimination of the intracellular pathogen is likely to be critically dependent on the activation of cell-mediated immune (CMI) responses governed by type 1 T helper (Th1) cells, which can prevent the invasion of host cells or detect intracellular pathogens and eliminate them (Kaufmann, 1993, Inglis and Sagripanti, 2006). Humoral responses are also considered to contribute significantly to the development of host protection to melioidosis, as evidenced by correlation of high titres of *B. pseudomallei* specific immunoglobulins (Ig) to improved clinical outcome (Wiersinga et al., 2006, Sarkar-Tyson and Titball, 2010). Even though immunization of animals with the capsule, LPS, live attenuated vaccines, killed whole-cell lysates or sub-unit vaccines confers partial protection against melioidosis, none of these

methods generate sterilizing immunity (Sarkar-Tyson and Titball, 2010, Choh et al., 2013). Thus a more complete understanding of the immune responses required to protect against infection is central to the development of a *B. pseudomallei* vaccine. The *Burkholderia* research community continues to identify and characterize *B. pseudomallei* antigens in search of promising targets for preventive strategies against melioidosis and for diagnostic assays. It is possible that even if sterile immunity is not achievable, vaccines could be used in conjunction with antibiotics or other therapeutics to treat melioidosis patients and to prevent relapse.

### **1.5 Antimicrobial Drug resistance**

*B. pseudomallei* is intrinsically resistant to many antimicrobial drugs, including first, second and third-generation cephalosporins, aminoglycosides, penicillins and polymyxin. It is usually susceptible to ceftazidime, the carbapenem antibiotics, amoxicillin-clavulanate (AMC), doxycycline and trimethoprim-sulfamethoxazole (TMP-SMX) (Wiersinga et al., 2012, Schweizer, 2012a). Primary ceftazidime resistance has been reported very rarely in isolates from Thailand (Wuthiekanun et al., 2011), Malaysia (Raja, 2008), and Singapore (Tan and Tan, 2008). A large study in Thailand revealed no evidence of primary or acquired carbapenem resistance in *B. pseudomallei* isolates (Wuthiekanun et al., 2011), but a small number of carbapenem-resistant isolates were reported in Singapore (Tan and Tan, 2008) and Malaysia (Raja, 2008, Ahmad et al., 2013) .

The antibiotic resistance mechanisms of *B. pseudomallei* range from exclusion from the bacterial cell due to permeability properties of the Gram-negative cell envelope (Nikaido, 2003), enzymatic inactivation, target deletion and efflux from the cell (Schweizer, 2012a, Schweizer, 2012b). The LPS of *B. pseudomallei* is modified by 4-amino-4-deoxy-L-arabinose, which presumably contributes to intrinsic high-level polymyxin B resistance (Novem et al., 2009). Maintenance of an intact LPS outer core oligosaccharide region also contributes to resistance to cationic antimicrobial peptides (Burtnick and Woods, 1999). Mechanisms involved in resistance to ceftazidime and other  $\beta$ -lactams (e.g. AMX, targets the periplasm) have been linked to the overproduction and mutation in the class A penA  $\beta$ -lactamase. Ceftazidime resistance has also been associated with the deletion of the penicillin binding protein 3 (BPSS1219). In Gram-negative bacteria, efflux pumps transport their substrates across the cytoplasmic membrane and can expel their substrates into the external milieu (Tal and Schuldiner, 2009, Nikaido and Pagès, 2012). The AmrAB-OprA efflux pump plays a role in the intrinsic aminoglycoside and macrolide resistance in many *B. pseudomallei* isolates (Moore et al., 1999). The BpeEF-OprC efflux pump contributes to intrinsic resistance to macrolides, fluoroquinolones, tetracyclines and chloroamphenicol (Chan and Chua, 2005, Mima and Schweizer, 2010).

## 1.6 Modes of persistence – environmental and clinical lifestyles

*B. pseudomallei* is a versatile organism that is able to persist in the environment as well as colonise a host and cause disease. It can survive for prolonged periods in harsh environmental conditions such as desiccation, fluctuating temperatures, high salt, and lack of nutrients (Wuthiekanun et al., 1995, Chen et al., 2003a, Inglis and Sagripanti, 2006, Shams et al., 2007, Tandhavanant et al., 2010, Larsen et al., 2013). It is naturally found in moist soil and surface water environments (White, 2003, Cheng and Currie, 2005b) where factors such as ingestion by amoebae (Inglis et al., 2000) and other natural predators may explain the range of determinants *B. pseudomallei* has developed through evolutionary time in its repertoire to survive within hosts cells. Humans are likely accidental hosts for the bacterium. However, very little is known about the underlying mechanisms that contribute to *B. pseudomallei* pathogenesis in mammalian hosts and there are likely many new factors that have yet to be identified and characterized.

During an infection, *B. pseudomallei* must first overcome various host defence mechanisms prior to reaching their cellular targets. For example, bacteria entering the respiratory tract would encounter a number of antimicrobial components such as lysozyme, complement proteins, defensins and cathelicidins. *B. pseudomallei* is known to be resistant to the killing action of defensins and complement but is susceptible to cathelicidin LL-37 (Wikraiphat et al., 2009). *B. pseudomallei* can adhere to, invade and replicate within a variety of eukaryotic cells, including phagocytic cells and epithelial cell lines derived from alveolar, bronchial, laryngeal and oral tissues, and exhibit an intracellular lifestyle (Harley et al., 1998).



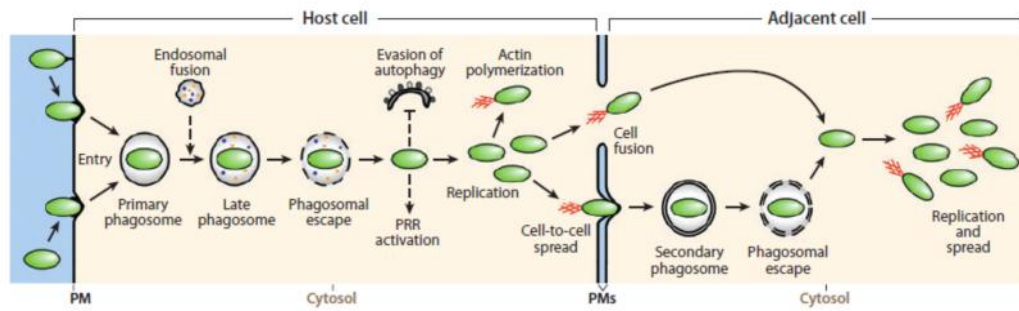

**Figure 1.3 Intracellular lifecycle of *B. pseudomallei* and *B. mallei*.**

(Reproduced from (Galyov et al., 2010))

*B. pseudomallei* can adhere to host cells by utilizing a pili encoded by *pilA* to mediate bacterial cell-cell interaction, which increases adhesion of microcolonies (Boddey et al., 2006). Other bacterial factors involved in adhesion to nonphagocytic cells include the adhesins BoaA and BoaB (Balder et al., 2010), the LPS and flagella (Inglis et al., 2003, Lu et al., 2012, Gan et al., 2012). The bacteria then enter the cell via phagocytosis or by inducing its own uptake into nonphagocytic cells. There is some evidence suggesting that the presence of the bacterial capsule can interfere with the uptake of *B. pseudomallei* by human neutrophils by limiting complement protein C3 deposition on the bacterial surface (Woodman et al., 2012). Upon uptake, the bacterium first enters into primary phagosomes before secreting Bsa type III secretion system (T3SS-3) effectors to promote the disruption of vacuolar membranes (Stevens et al., 2002). The bacterium then escapes into the cytosol, and hijack the host cell actin polymerization machinery for motility (Stevens et al., 2005b). *B. pseudomallei* evades killing by host cellular defences such as autophagy, induces nitric oxide synthase (iNOS), nitric oxide and proinflammatory cytokine production (Utai-incharoen et al., 2001) and replicates within the cytosol. The bacterium then induces plasma

membrane fusion, causing the formation of multinucleated giant cells (MNGCs) (Kespichayawattana et al., 2000). The bacteria may spread to adjacent cells through the formation of actin-based membrane protrusions that can lead to either direct internalization into the adjacent cell (Stevens et al., 2005b) or to fusion and formation of MNGCs (Kespichayawattana et al., 2000). This ability to cause eukaryotic cells to fuse and undergo morphological changes analogous to those observed during osteoclastogenesis is not well understood. The intracellular lifestyle of *B. pseudomallei* is thought to enhance its survivability and latency in hosts by allowing the bacteria to evade the host immune system.

Identifying additional bacterial features or 'virulence factors' that enable *B. pseudomallei* to establish itself within a host and enhance its potential to cause disease may shed light on the various aspects of the bacterial life cycle and hopefully provide information on the nature of *B. pseudomallei* as a pathogen in mammalian hosts. In this context, the virulence factors are defined as genes and proteins that enable initial colonization, dissemination and/or immune evasion.

### **1.7 Methods used for the identification of virulence factors**

Strategies used to identify virulence factors that contribute to the pathogenicity of *B. pseudomallei* include genomic comparison, transposon mutagenesis and *in vivo* expression technology (IVET). Prior to the availability of genome sequences, comparative studies using subtractive hybridisation between the virulent *B. pseudomallei* and the similar, but

relatively avirulent *B. thailandensis* revealed a number of candidate genes that are unique to *B. pseudomallei* (Brown et al., 2000, Reckseidler et al., 2001). By inspecting sequenced genomes, candidate virulence factors can also be predicted by analogy to other pathogens (Holden et al., 2004). Methods utilizing transposon mutants (signature-tagged mutagenesis (STM) and transposon-directed insertion-site sequencing (TraDIS)) have been used to identify *B. pseudomallei* genes important for *in vitro* and *in vivo* virulence (DeShazer et al., 1998, Atkins et al., 2002a, Pilatz et al., 2006, Cuccui et al., 2007, Moule et al., 2014). IVET is a method of identifying genes which are upregulated under specific conditions, such as those important for survival within macrophages (Shalom et al., 2007).

### **1.8 Selected virulence factors**

*B. pseudomallei* has a number of virulence factors that allow it to enable initial colonization, dissemination and/or immune evasion and hijack the host cell machinery for its survival, replication, spread and persistence (Galyov et al., 2010). Some of the key virulence factors for Bps include the capsule, type IV pili (TFP), quorum sensing molecules, LPS O-antigenic polysaccharide, type III secretion system (Bsa T3SS), type VI secretion system (T6SS), flagellin, and type III and type IV O-polysaccharide (O-PS). These major virulence factors are deemed important for various stages of the bacterial intracellular lifecycle. However, a holistic understanding of how the bacterium interacts with the host and the complex nature of the bacterial life cycle remains to be elucidated (Allwood et al., 2011). A more comprehensive understanding of how *B. pseudomallei* exploit host cells will provide

invaluable insights into pathogenesis of melioidosis and aid in the development and improvement of novel therapeutics and vaccines. Some of the major *B. pseudomallei* virulence factors are described as follows.

### **1.8.1 Surface polysaccharides: Capsule and lipopolysaccharides**

Surface-associated molecules such as the capsule and LPS are structures that constitute the outermost layer of the bacteria cell and are often involved in mediating direct interactions between the bacteria and its environment. The capsule of Gram-negative bacteria is composed of highly hydrated polyanionic polysaccharides that are linked to the cell surface of the bacterium via covalent attachments to either phospholipid or lipid-A molecules, or may be associated with the cell in the absence of a membrane anchor (Roberts, 1996). The capsular polysaccharides (CPS) can be homo- or heteropolymers composed of repeating monosaccharides joined by glycosidic linkages, and are often antigenic. Capsules have various roles including determining access of molecules to the cell membrane, resistance to specific and non-specific host immunity, mediating adherence to surfaces, and prevention of desiccation (Roberts, 1996). Capsules have been deemed as important virulence determinants in a wide range of bacterial pathogens including *Escherichia coli* K1 (Robbins et al., 1974), *Streptococcus* spp. (Smith et al., 1999), *Actinobacillus pluropneumoniae* (Ward et al., 1998), *Haemophilus influenzae* (Kroll et al., 1993) and *Pasteurella multocida* (Boyce and Adler, 2000).

The LPS is a major outer membrane component of Gram-negative bacteria, and has an essential barrier function in protection against harsh

environments and toxic compounds, as well as in signalling host innate immune responses (Caroff and Karibian, 2003). It is composed of an outer O-antigenic polysaccharide (O-PS) or oligosaccharide, and an inner core oligosaccharide that is covalently linked to the lipophilic moiety termed lipid A (bacterial endotoxin). The O-PS is diverse in length and composition amongst different Gram-negative bacteria species, and typically determines serotype specificity (Alexander and Rietschel, 2001). The polysaccharide moiety plays protective roles, such as evasion of complement attack or camouflage with common host carbohydrate residues, while the lipid A moiety is associated with immunostimulatory activity (Rietschel et al., 1994, Matsuura, 2013). A recent study confirmed that *B. pseudomallei* LPS triggers TLR4-dependent immune activation, particularly in human whole blood, and suggested that LPS play an important role in stimulating the host response in melioidosis, particularly in the stimulation of TNF- (Chantratita et al., 2013). During an infection, host cells may produce proinflammatory cytokines upon recognition of LPS, but overstimulation of the host cells by LPS can lead to septic shock (Leon et al., 2008).

*B. pseudomallei* expresses at least four surface polysaccharides, two of which (capsule and LPS) have been shown to be important for virulence (DeShazer et al., 1998, Reckseidler et al., 2001, Holden et al., 2004, Cuccui et al., 2007, Sarkar-Tyson et al., 2007). The *B. pseudomallei* capsule contains the distinct type I O-PS moieties, which is an unbranched homopolymer with the structure -3)-2-O-acetyl-6-deoxy- -D-mannoheptopyranose-(1- (Perry et al., 1995, Reckseidler et al., 2001). The capsule is an important virulence factor, particularly in intraperitoneal and intranasal

murine infection models, as mutants deficient in capsule expression are avirulent in mice and Syrian hamsters and are unable to survive in blood (Reckseidler et al., 2001, Lazar Adler et al., 2009, Cuccui et al., 2012). Although the capsule is essential for *B. pseudomallei* to cause disease, the molecular mechanisms and interactions with the host are not fully understood. The capsule plays a role in reducing complement factor C3b deposition, thus allowing the bacteria to evade the host innate immune response such as the complement cascade and opsonin-dependent phagocytosis (Reckseidler-Zenteno et al., 2005). However, an acapsular *B. pseudomallei* mutant was resistant to killing by 30 % normal human serum, presumably because they still express LPS, a factor that contributes to serum resistance (Woodman et al., 2012). Introduction of purified *B. pseudomallei* capsule enhances the survival of serum-sensitive strains in normal human serum as well as increased the *in vivo* virulence of an acapsular mutant (Reckseidler-Zenteno et al., 2005). A recent study suggests that the capsule confers some degree of resistance against intracellular killing by human macrophages (Wikraiphat et al., 2009), while another study suggests that the capsule hampers internalization of *B. pseudomallei* into nonphagocytic cells but does not seem to play a role in intracellular replication or cytotoxicity in these cells (Phewkliang et al., 2010). Taken together, these studies imply that the capsule is a major virulence factor that affects *in vivo* virulence, survival in blood, phagocytosis and *in vitro* survival within phagocytes, thus allowing for the bacteria to survive and colonise in order to establish acute and/or chronic infections.

The capsule is also required for virulence in the closely related *B. mallei* (DeShazer et al., 2001), and is generally absent in the avirulent *B. thailandensis*. However, two variant strains of *B. thailandensis* (CDC3015869 and E555) were recently shown to encode and express a *B. pseudomallei*-like CPS but they did not display enhanced virulence in mice, suggesting other factors are required to act in concert for full virulence in mammals (Sim et al., 2010).

Four distinct antigenic types of *B. pseudomallei* LPS have been reported: typical (type A), atypical (type B and B2) and rough types (Anuntagool et al., 2006, Tuanyok et al., 2012). The serotype A LPS of *B. pseudomallei* contains the type II O-PS moiety which is an unbranched heteropolymer with repeating D-glucose and L-talose units with the structure  $\beta$ -D-glucopyranose-(1-3)-6-deoxy- $\beta$ -L-talopyranose-(1-, in which approximately 33 % of the L-6dTalp residues bear 2-O-methyl and 4-O-acetyl substituents whereas the other L-6dTalp residues bear only 2-O-acetyl substituents (Perry et al., 1995, DeShazer et al., 1998). The LPS of the avirulent *B. thailandensis* is highly similar to that of *B. pseudomallei* (type A) and is cross reactive to sera obtained from *B. pseudomallei* infections (Anuntagool et al., 1998, Ngugi et al., 2010, Tuanyok et al., 2012). In a recent study, the *B. thailandensis* LPS confers partial protection against melioidosis in a mouse model of infection (Ngugi et al., 2010).

The *B. pseudomallei* LPS is a major virulence factor that affects *in vivo* virulence in intraperitoneal animal models (hamsters, guinea-pigs and infant diabetic rats) and contributes to human serum sensitivity and survival in rat and guinea-pig infection models (DeShazer et al., 1998). The LPS also

contributes to *in vitro* survival in human macrophages (Wikraiphat et al., 2009). This is likely due, at least in part, to the suppression of cytokine secretion (IFN- ) and inducible nitric oxide synthase (iNOS), which leads to the reduction in bactericidal activity (Arjcharoen et al., 2007). The LPS is also involved in conferring resistance to cationic antimicrobial peptides (polymyxin B) (Burtnick and Woods, 1999, Rosenfeld and Shai, 2006). Despite the apparent virulence deficits of LPS mutants in animal models and *in vitro* assays, clinical isolates which express no detectable O-antigen and display no reduction in resistance to killing by human sera have been identified (Anuntagool et al., 2006).



## 1.8.2 Secretion systems

Many pathogens utilize protein secretion systems to interact with their environments and host cells. To date, six general classes of protein secretion systems have been described for Gram-negative bacteria, some of which are shared with Gram-positive bacteria (reviewed in (Tseng et al., 2009)). A unique type VII system has been described for Gram-positive bacteria. The main features of the known secretion systems are summarized in Figure 1.4 (Tseng et al., 2009). In the case of Gram-negative bacteria, the secreted proteins are either exported across the inner and outer membrane in a single step via the type I, type III, type IV or type VI pathways, or first exported into the periplasmic space via the Sec or two-arginine (Tat) pathways and then translocated across the outer membrane via the type II or type V machinery. The proteins exported by these systems may provide *in vitro* and *in vivo* growth advantage to pathogens (Sun et al., 2010, Russell et al., 2014).

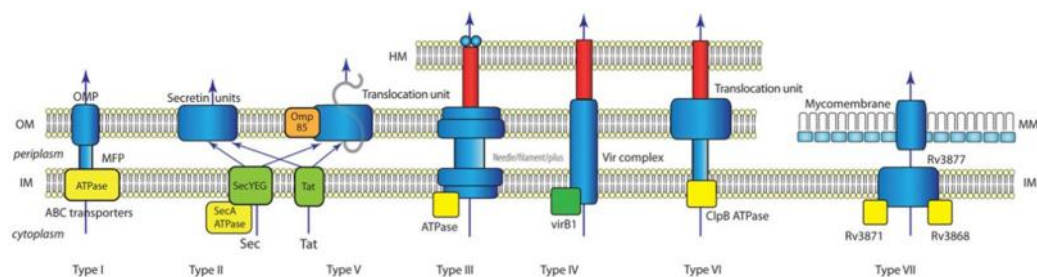

**Figure 1.4 Summary of known bacterial secretion systems**

Only the basics of each secretion system are sketched. HM: Host membrane; OM: outer membrane; IM: inner membrane; MM: mycomembrane; OMP: outer membrane protein; MFP: membrane fusion protein. ATPases and chaperones are shown in yellow (Reproduced from (Tseng et al., 2009).

### 1.8.2.1 Type 3 secretion systems

Type 3 secretion systems (T3SSs) are complex bacterial structures that act as unique protein translocation systems to inject bacterial proteins (effectors) into the host cell cytoplasm, bypassing the extracellular milieu (Ghosh, 2004, Coburn et al., 2007). A subset of T3SS secreted proteins (translocators) mediate the delivery of effector proteins across bacterial and host cell membranes. The effectors can alter host cell functions, including causing changes to the host cell cytoskeleton to promote attachment and invasion of the bacteria, interfering with cellular trafficking processes, inducing cytotoxicity and barrier dysfunction, and immune system subversion. The T3SSs have been linked to infection progression and virulent outcome for many Gram-negative pathogens (Coburn et al., 2007).

*B. pseudomallei* T3SS translocator and effector proteins were initially identified based on sequence similarity to those found in other bacterial species such as *Salmonella* and *Shigella* species (Attree and Attree, 2001). *B. pseudomallei* has at least three loci encoding putative T3SSs clusters (Rainbow et al., 2002), with the Bsa (*Burkholderia* secretion apparatus) T3SS (T3SS-3) playing a major role in virulence, invasion of non-phagocytic cells, escape from endocytic vacuoles into the cytoplasm, and avoiding degradation by the host lysosomal system, and multinucleated giant cell (MNGC) formation (Stevens et al., 2002, Stevens et al., 2004). For MNGC formation to occur, bacteria must escape the phagosome and be motile within the host cell cytosol, thus Bsa T3SS is likely to be involved in this process primarily due to its role in upstream intracellular events such as escape from endocytic vacuoles (French et al., 2011). Translocator proteins

BipB, BipC and BipD, are important for bacterial virulence in both *in vivo* and *in vitro* studies, but did not appear to induce protective properties against *B. pseudomallei* challenge (Stevens et al., 2004, Druar et al., 2008). The inability of these T3SS proteins to act as protective antigens suggests that the proteins are either expressed in low levels during infection or that the antibodies do not have access to the predominantly intracellular bacteria (Druar et al., 2008). The effector proteins BopE and BopA were shown to be important for subversion of host cell mechanisms, particularly in invasion of epithelial cells and phagocytic cell survival respectively, but are not required for virulence in the BALB/c mice infection model (Stevens et al., 2003, Stevens et al., 2004, Cullinane et al., 2008, Gong et al., 2011). The T3SS-3 is an important virulence determinant of *B. pseudomallei* pathogenesis, but the precise mechanisms for the role of the various components of the system in host-pathogen interactions is likely to be complex and remain to be elucidated.

#### **1.8.2.2 Type 6 secretion system**

The type 6 secretion system (T6SS) is the most recently identified protein secretion system in Gram-negative bacteria (Pukatzki et al., 2006). It forms a needle-like injection device which closely resembles the bacteriophage tail and secretes effectors that appears to have anti-eukaryotic properties or antibacterial activity (Coulthurst, 2013). T6SSs are encoded by large, variable gene clusters, but they contain 13 'core' essential and conserved genes (TssA-TssM), which are believed to encode the basic secretion apparatus. This nomenclature encompasses previously identified T6SS-

associated genes including *hcp* (hemolysin co-regulated protein), *vgrG* (valine glycine repeat proteins), *icmF* (intracellular multiplication factor) (Coulthurst, 2013).

The *B. pseudomallei* K96243 encodes six T6SS gene clusters, the *B. mallei* ATCC23344 genome encodes four gene clusters and the *B. thailandensis* E264 genome encodes five T6SS clusters (Shalom et al., 2007, Schell et al., 2007). T6SS clusters 1 to 3 are present in all three species, cluster 4 is only unique to *B. pseudomallei* and *B. mallei*, and cluster 5 is found in *B. pseudomallei* and *B. thailandensis*. To date, the T6SS-1 (BPSS1496-1512), present in all three organisms, is the best characterised and has been shown to be a major virulence factor in *B. pseudomallei* and *B. mallei*. T6SS-1 was shown to be induced inside murine macrophages, involved in intracellular replication and MNGC formation, and important for bacterial virulence in mice (Pilatz et al., 2006, Shalom et al., 2007, Chen et al., 2011, French et al., 2011, Toesca et al., 2014).

### **1.8.3 BimA motility**

During the intracellular lifecycle, *B. pseudomallei* and *B. thailandensis* enters primary phagosomes and then secretes Bsa T3SS effectors to promote the disruption of vacuolar membrane. Once in the cytosol, the bacterium induces its own propulsion by polymerising actin at one bacterial pole, a process known as actin-based motility (Stevens et al., 2005b). Actin-based motility is associated with intercellular spread in several intracellular bacterial pathogens (Stevens et al., 2006, Yoshikawa et al., 2009). The *Burkholderia*

intracellular motility factor, BimA, was identified through *in silico* analysis and was shown to mediate intracellular actin polymerization (Stevens et al., 2005b, Sitthidet et al., 2008). The formation of bacteria-tipped actin-rich membrane protrusions aids, in part, in the intercellular spread into adjacent cells. A *B. pseudomallei* BimA mutant exhibited attenuation in a murine model of melioidosis (Sitthidet et al., 2011). *B. thailandensis* also appears to exhibit a BimA-dependent intracellular actin-based motility, and motility defects associated with *B. pseudomallei* BimA mutants can be complemented with the expression of *B. thailandensis bimA* (Stevens et al., 2005a).

#### **1.8.4 Flagella and pili**

Flagella are filamentous protein structures attached to the cell surface that provide swimming movement and motility to the bacterial cell, facilitating adhesion and invasion in some strains. Pili are short, hair-like structures on bacterial surfaces that are often involved in adherence of bacterial cells to surfaces. Type IV pili (TFP) are important for virulence in many Gram-negative bacteria as they can facilitate bacterium-bacterium interactions that result in microcolonies and/or biofilms, and enhance protection from host defences (Strom and Lory, 1993, Craig et al., 2004). Motility and adhesion properties facilitate bacterial colonization of host tissues and have been implicated in bacterial pathogenesis (Chua et al., 2003).

The *B. pseudomallei* flagella are required for the adhesion and invasion of the free living amoeba *Acanthamoeba astronyxis* (Inglis et al., 2003) but the

importance of the flagella in causing virulence in mammalian models remains debatable. The flagellum is not required for virulence in the Syrian hamster or diabetic rat intraperitoneal infection model, and conflicting data exist for the BALB/c mice intraperitoneal infection model (DeShazer et al., 1997, Chua et al., 2003, Wikraiphat et al., 2009). Even though an aflagellate mutant was able to retain its ability to invade A549 lung epithelial cells *in vitro*, the mutant displayed attenuation of virulence in BALB/c mice intranasal infection model (Chua et al., 2003). It is possible that the flagella have an important role in virulence, but the role can be overcome or subverted in more acute infection models, such as diabetic rats or hamsters.

The *B. pseudomallei* K96243 genome is reported to encode eight potential type IV pili (TFP)-associated loci (Essex-Lopresti et al., 2005). A *B. pseudomallei* K96243 mutant with a defective type IV A pilin gene, *pilA*, displayed reduced virulence in a BALB/c mice infected via the intranasal route but not the intraperitoneal route, indicating a possible role in initial epithelial cell attachment (Essex-Lopresti et al., 2005). Expression of *pilA* appears to be differentially regulated and PilA have different roles between *B. pseudomallei* strains 08 and K96243 (Boddey et al., 2006). The *pilA* gene plays a role in adherence of K96243 strain to epithelial cells and bacterium-bacterium interaction (formation of microcolonies) in the 08 strain, which increases the number of bacteria in association with host cells (Essex-Lopresti et al., 2005, Boddey et al., 2006). Given that there are many putative TFP-associated loci in *B. pseudomallei*, it is possible that the expression of pili is regulated in a complex manner and that different pili may mediate interactions with specific host receptors (Essex-Lopresti et al., 2005).

## 1.9 Bacterial lipoproteins

Bacterial lipoproteins are a set of membrane proteins that serve diverse roles, including those involved in pathogenesis. Lipid modification of bacterial proteins facilitates the anchoring of hydrophilic proteins to hydrophobic surfaces such as the cell wall phospholipids (PL), where the protein can function. Many bacterial lipoproteins have been shown to exhibit pleiotropic effects on cellular physiology and perform various roles including colonization, evasion of host defences, immunomodulation, nutrient uptake, signal transduction, outer membrane stability, adhesion, conjugation, transport, and contributing to antibiotic resistance (reviewed in (Kovacs-Simon et al., 2011)). Lipoproteins of numerous pathogens have also been promoted as vaccine candidates (Kovacs-Simon et al., 2011).

In prokaryotes, membrane lipoproteins are initially translated into pre-lipoproteins with a precursor signal peptide at the N-terminus, which directs the protein through the membrane and is then proteolytically cleaved. The signal peptide consists of approximately 20-30 amino acids, mostly hydrophobic in nature, and then ending in a highly conserved lipobox sequence with an invariant cysteine residue ([LVI][ASTVI][ASG]C) (Inouye et al., 1977). The lipobox sequence is essential for correct protein processing (Figure 1.5). The invariant cysteine residue is first modified through the covalent attachment of a diacylglycerol moiety to the thio group on the side chain, catalysed by the enzyme lipoprotein diacylglyceryl transferase (Lgt), resulting in a prolipoprotein (Figure 1.6, (Babu et al., 2006)). After lipidation, the prolipoprotein is cleaved by a specific lipoprotein signal peptidase (signal peptidase II, Lsp or SPase II), and leaves the cysteine residue of the lipobox

as the new amino-terminal residue (Tokunaga et al., 1982). In Gram-negative bacteria, the cleaved prolipoprotein is acylated by an attachment of an amide-linked acyl group to the N-terminal cysteine residue, catalysed by lipoprotein N-acyl transferase (Lnt), resulting in a triacylated mature lipoprotein (Gupta et al., 1993). The diacylglyceryl and acyl group are derived from membrane phospholipids and provide tight anchorage of the lipoprotein to the membrane (Hantke and Braun, 1973).



**Figure 1.5 Schematic of a typical lipoprotein sequence**

A typical lipoprotein sequence of an n-region with positively charged amino acids in the initial residues, a hydrophobic h-region with 7 to 22 predominantly hydrophobic and uncharged residues, and c-region with a consensus lipobox sequence [LVI][ASTVI][ASG], along with the invariant cysteine residue (Babu et al., 2006).



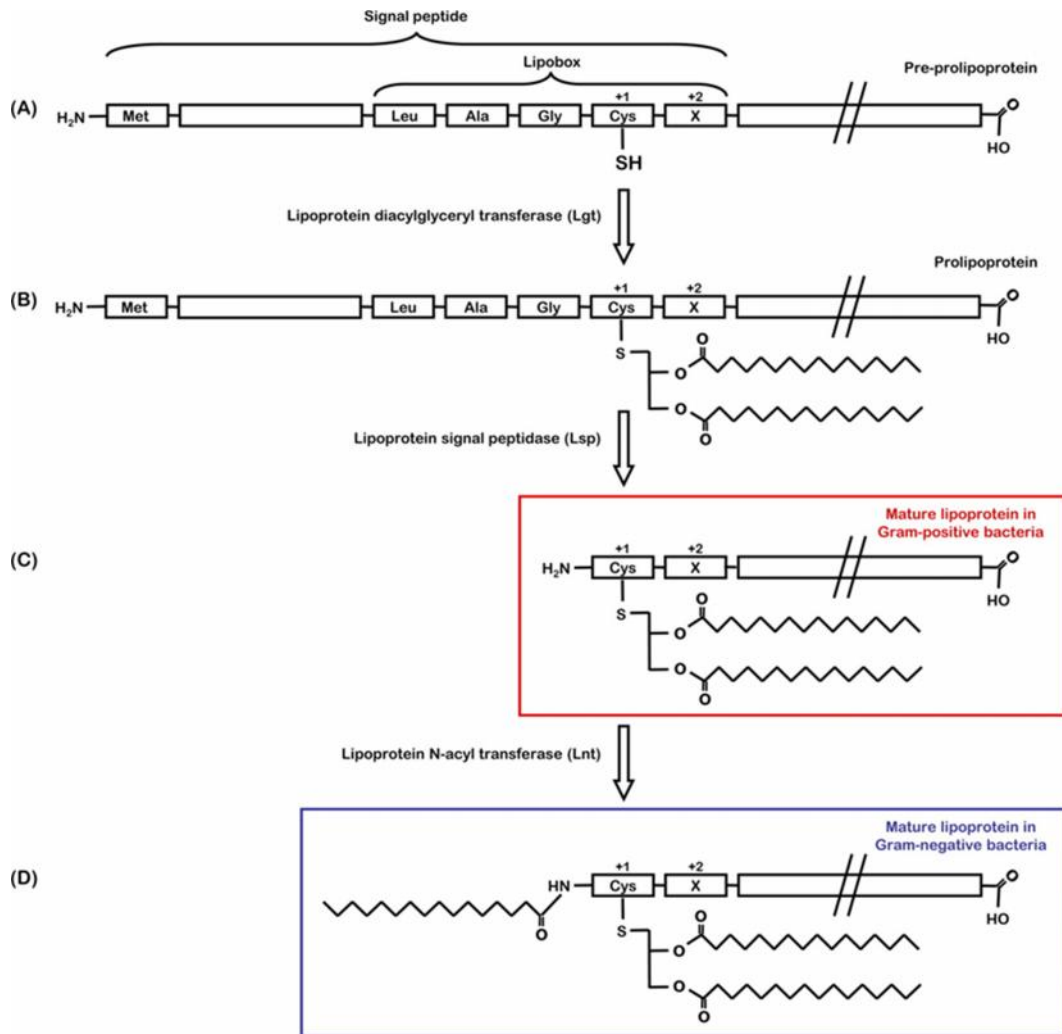

**Figure 1.6 Biosynthesis of bacterial lipoproteins.**

Reproduced from (Kovacs-Simon et al., 2011).

Mature lipoproteins are localized to various sites within the cell wall, including the periplasmic face of the inner or outer membranes by the lipoprotein localization machinery (Lol), which consists of an LolCDE complex, an ATP-binding cassette (ABC) transporter and the periplasmic chaperone, LolA (Tokuda and Matsuyama, 2004, Tokuda, 2009, Kovacs-Simon et al., 2011). The amino acids adjacent to the conserved cysteine at the +2, +3 and +4 positions have a role in determining localization of the lipoprotein in the outer membrane (Yamaguchi et al., 1988, Narita and Tokuda, 2007, Silva-Herzog

et al., 2008). All of the known lipoproteins in *E. coli* face the periplasm (Bos et al., 2007), but lipoproteins are present on the outer leaflet of the outer membrane in some Gram-negative bacteria (Kovacs-Simon et al., 2011).

Lipoproteins contribute to the integrity of the cell wall. The outer membrane (OM) of Gram-negative bacteria is separated from the inner membrane phospholipid bilayer by an aqueous periplasm and a thin peptidoglycan layer. The outer membrane is largely asymmetrical, with mostly LPS present in the outer leaflet and phospholipids in the inner leaflet, forming an effective barrier against toxic environments (Nikaido, 2003). The lipid A portion of LPS produces a lipid interior of very low fluidity, which makes the LPS/PL layer less permeable to lipophilic molecules and most antibiotics (Nikaido, 2003). The Braun (muerin) lipoprotein, an abundant cell envelope protein in many Gram-negative bacteria, binds to peptidoglycan via a peptide bond and is embedded into the outer membrane by covalent linkages, contributing to cell wall integrity (Silhavy et al., 2010, Dramsi et al., 2008).

Lipoproteins are required for virulence in many pathogenic bacteria. In *Mycobacterium tuberculosis* the Mce (mammalian cell entry) family of proteins enable the pathogen to invade mammalian cells (Casali and Riley, 2007), the *Streptococcus pneumoniae* PsaA (pneumococcal surface adhesion A) plays a role in adhesion to epithelial cells and resistance to oxidative stress (reviewed in (Kovacs-Simon et al., 2011)). Other examples of lipoproteins that are involved in pathogenesis include the Braun lipoprotein in *Yersinia pestis* (Sha et al., 2008), the *M. tuberculosis* 19-kDa lipoglycoprotein (potent inducer of Toll-like receptor 2 [TLR2] and pleiotropic effects on immune response) (Pai et al., 2003, Wilkinson et al., 2009), the

*Neisseria meningitidis* GNA1870 (also called the factor H binding protein [fHBP], contributes to resistance to serum-mediated killing and antimicrobial peptide binding) (Madico et al., 2006, Seib et al., 2009), and *Borrelia burgdorferi* OspE (serum resistance) (Hellwage et al., 2001). In some of these cases, disruption of these lipoproteins in pathogens has led to attenuation of virulence in animal models of infection (Henao-Tamayo et al., 2007, Sha et al., 2008). However, to date, lipoproteins in *B. pseudomallei* have not been well studied. Within the *Burkholderia* genus, the peptidoglycan-associated lipoprotein (PAL), Opcl and the outer membrane lipoprotein SlyB (or PCP, PAL cross-reactive protein) protein are conserved in all representatives of the *B. cepacia* complex and contribute to membrane integrity (Plesa et al., 2006, Plesa et al., 2004). A STM study by Cuccui *et al.* (2007) (Cuccui et al., 2007) identified a VacJ orthologue (BPSL3147) in *B. pseudomallei* as being important for *in vivo* virulence. Since lipoproteins have been shown to be important in infection and disease progression in many bacteria, understanding the roles that they play in *B. pseudomallei* may present as novel opportunities to understand *Burkholderia* pathogenesis and design novel therapeutic agents. Furthermore, immunogenic surface-exposed lipoproteins have been shown to be protective against a number of bacterial pathogens, and may have an important role to play in the future development of vaccines (Edelman et al., 1999, Grode et al., 2002). Further understanding of the roles of lipoproteins may contribute to future development of novel antibacterials.

## 1.10 VacJ/MlaA family lipoproteins

Recently, Malinverni and Silhavy (2009) characterized a novel mechanism involving a highly conserved Mla (maintenance of OM lipid asymmetry) ABC transport system, with a lipoprotein component (MlaA/VacJ), that impacts cell surface phospholipids and aids in the maintenance of the OM asymmetry in *E. coli* (Malinverni and Silhavy, 2009). The Mla system has a predicted import function, which prevents the accumulation of phospholipid accumulation in the outer leaflet of the outer membrane. Accumulation of phospholipids in the outer leaflet indicates packing disruptions of the OM and reduces the barrier function (Nikaido, 2005). Mutations of the components in the Mla system results in increased OM permeability, but the defect can be compensated with the increased expression of another OM protein, PldA, a phospholipase that destroys surface-exposed phospholipids (Malinverni and Silhavy, 2009). Mutation of MlaA orthologues also affects the OM integrity in *H. influenzae* (Nakamura et al., 2011), *Shigella flexneri* (Carpenter et al., 2014) and *Acinetobacter baumannii* (R. Stabler, personal communication).

The MlaA lipoprotein of the Mla pathway contributes to virulence in some bacteria. The 28 kDa VacJ (virulence associated chromosome locus J) lipoprotein was first identified in *S. flexneri* (Suzuki et al., 1994) and it is orthologous to MlaA in *E. coli*. VacJ/MlaA is thought to contribute to virulence by playing a role in intercellular spread through an undefined mechanism (Suzuki et al., 1994). Many pathogens retain the ability to survive in human blood serum, where they will encounter bactericidal antibodies and complement activity. The VacJ/MlaA orthologue in *H. influenzae* contributes to serum resistance in acapsular, non-typeable strains (NTHi), allowing the

bacterium to adapt to inflammation encountered during infection of the lower respiratory tract (Nakamura et al., 2011). Nakamura *et al.* (Nakamura et al., 2011) suggested that modulation of phospholipid levels in the outer membrane affects the packing of the *H. influenzae* lipooligosaccharide molecules, which in turn limits the accessibility of oligosaccharide epitopes that are recognized by bactericidal antibodies in the complement system. In these bacteria, the VacJ family of lipoproteins contribute to the maintenance of the outer membrane structure and stability, which in turn, contribute to pleiotropic phenotypes such as resistance to detergents and bactericidal antibodies, and possibly affect other virulence factors that are important for survival in niche environments.

### **1.11 Project aims**

The principle objective of this project was to evaluate the role of the lipoprotein VacJ, in *Burkholderia* pathogenesis.

This objective can be broadly summarized in the following specific aims:

- 1) To predict potential role(s) of VacJ through bioinformatics analyses
- 2) To generate mutants, biochemical tools and reagents to evaluate the role(s) of VacJ for *in vitro* and *in vivo* virulence

## **2. Chapter 2 – Materials and Methods**

### **2.1 Chemicals and Reagents**

All reagents were purchased from Sigma-Aldrich Company Ltd (Dorset, UK) unless otherwise stated. Media used to grow bacteria and cell lines in this study are listed in Table 2.1. Buffer components are defined in Appendix 1. Milli-Q grade water (Millipore, Billerica, USA) was used to prepare media and buffers that were then autoclave sterilized at 121°C for 20 minutes.

### **2.2 Biosafety containment level 3 safety protocols**

*B. pseudomallei* was handled using containment level 3 laboratory procedures. All techniques carried out under biosafety containment level 3 conditions in conjunction with risk assessment forms were approved by the Faculty Safety Office. Novel techniques to be carried out on *B. pseudomallei* K96243 were first attempted under standard laboratory conditions with *B. thailandensis* E264 to assess potential risks. Versions of all newly developed protocols have been stored electronically and are available for use by approved workers.

## **2.3 Bacteria and Cell lines**

### **2.3.1 Bacterial strains and culture conditions**

The bacterial strains and plasmids used in this study are described in Tables 2.2 – 2.3. All bacterial strains were routinely grown at 37°C in Luria bertani (LB) agar or LB broth with 200 rpm shaking. When required, antibiotics were added to the medium at the following concentrations: ampicillin (Amp) 100 µg/ml; kanamycin (Km) 50 µg/ml (for *E. coli*), 400 µg/ml (for *Burkholderia* mutants); chloroamphenicol (Cm) 30 µg/ml; tetracycline (Tet) 20 µg/ml; zeocin (Zeo) 100 µg/ml. *E. coli* MFD cultures were supplemented with 0.3 mM diaminopimelic acid (DAP). Frozen bacterial stocks were maintained at -70°C and prepared by mixing an equal volume of saturated bacterial culture and 50 % glycerol.

**Table 2.1 Growth media used in this study**

<b>Media</b>	<b>Composition</b>	<b>Source</b>
LB broth, Miller	Per litre: 10 g tryptone, 5 g yeast extract, 10 g sodium chloride	Becton, Dickinson & Company, Franklin Lakes, USA
LB agar, Miller	Per litre: 10 g tryptone, 5 g yeast extract, 10 g sodium chloride, 15 g agar	Becton, Dickinson & Company, Franklin Lakes, USA
Sucrose Agar	Per litre: 10 g tryptone, 5 g yeast extract, 100 g sucrose, 15 g agar	Becton, Dickinson & Company, Franklin Lakes, USA
Growth media for J774A.1	Dulbecco's modified eagle medium (DMEM) containing 4.5 g/L glucose, 4 mM L-glutamine and 3.7 g/L sodium bicarbonate, 10 % foetal calf serum	Sigma-Aldrich
Growth media for A549	Gibco® F-12K (Kaighn's) Medium (Invitrogen), 10 % foetal calf serum	Invitrogen
Super Optimal broth with catabolite repression (SOC) medium	2 % tryptone, 0.5 % yeast extract, 10 mM NaCl, 2.5 mM KCl, 10 mM MgCl <sub>2</sub> , 10 mM MgSO <sub>4</sub> , 20 mM glucose	Bioline
Cation-adjusted Mueller-Hinton broth (CAMHB)	Per litre: approximate formula 3 g beef extract, 17.5 g acid hydrolysate of casein, 1.5 g starch; supplemented to achieve 20 to 25 mg Ca <sup>++</sup> /L and 10 to 12.5 Mg <sup>++</sup> /L	Becton Dickinson



**Table 2.2 List of strains used in this study**

Strain	Description	Reference
<i>B. pseudomallei</i> strains		
K96243	Clinical isolate isolated from a 34-year old female diabetic patient with melioidosis in Thailand in 1996; Km <sup>R</sup> , Zeo <sup>R</sup> , Gm <sup>R</sup>	(Sarkar-Tyson et al., 2007)
K96243 BPSL3147	K96243 derivative; unmarked deletion of <i>bpsI3147</i>	This study
7A1	K96243 derivative; Tn5:: <i>bpsI3147</i> ; Km <sup>R</sup>	(Cuccui et al., 2007)
13H8	K96243 derivative; Tn5:: <i>wcbB</i> ; Km <sup>R</sup>	(Cuccui et al., 2007)
13H8 BPSL3147	K96243 derivative; Tn5:: <i>wcbB</i> , unmarked deletion of <i>bpsI3147</i> ; Km <sup>R</sup>	This study
<i>B. thailandensis</i> strains		
E264	Soil isolate from rice field in Central Thailand; Km <sup>R</sup> , Zeo <sup>R</sup> , Gm <sup>R</sup>	A. Scott (DSTL)
E264 BTH_I3001	E264 derivative; unmarked deletion of <i>bth_i3001</i>	This study
E264 BTH_II2351	E264 derivative; unmarked deletion of <i>bth_ii2351</i>	This study
E264 DB	E264 derivative; unmarked deletions of <i>bth_i3001</i> and <i>bth_ii2351</i>	This study
BTH_I3001 + pMEKVacJBT	E264 derivative; unmarked deletion of <i>bth_i3001</i> ; containing the complementation construct pMEK VacJBT; Km <sup>R</sup>	This study
BTH_I3001 + pMEVacJBT	E264 derivative; unmarked deletion of <i>bth_i3001</i> ; containing the complementation construct pME VacJBT; Tet <sup>R</sup>	This study
DB + pMEKVacJBT	E264 derivative; unmarked deletion of <i>bth_i3001</i> and <i>bth_ii2351</i> ; containing the complementation construct pMEK VacJBT; Km <sup>R</sup>	This study
<i>E. coli</i> strains		
Top10	For propagation of pJET or pGEM-T plasmid; F- <i>mcrA</i> ( <i>mrr-hsdRMS-mcrBC</i> ) 80 <i>lacZ</i> M15 <i>lacX74 recA1 araD139 (ara leu) 7697 galU galK rpsL</i> (StrR) <i>endA1 nupG</i>	Life Technologies
MFD	Conjugative donor of <i>pir</i> -dependent suicide replicon pDM4 and its derivatives; K-12 wild-type strain RP4-2-Tc::[Mu1:: <i>aac(3)IV- aphA- nic35- Mu2::zeo</i> ] <i>dapA::(erm-pir) recA</i>	(Ferrières et al., 2010)

**Table 2.3 List of plasmids used in this study**

Plasmid	Description	Reference / Source
pGEM®-T Easy Vector	Cloning vector, Amp <sup>R</sup>	Promega
pJET1.2/blunt	Cloning vector, Amp <sup>R</sup>	Fermentas
pDM4	pir-dependent suicide replicon for allelic exchange in <i>Burkholderia</i> ; R6K ori, RP4 Mob ; <i>sacBR</i> ; <i>cat</i> , Cm <sup>R</sup>	Milton 1996
pDM4- vacJ <sub>Bp</sub>	Mutagenesis construct for <i>B. pseudomallei</i> (for mutagenesis of <i>bpsI3147</i> ).	This study
pDM4- vacJ <sub>Bt</sub>	Mutagenesis construct for <i>B. thailandensis</i> (for mutagenesis of <i>bth_i3001</i> ).	This study
pME6032	Shuttle vector with ori <sub>p15A</sub> , ori <sub>pVS1</sub> , IPTG inducible tac promoter (Ptac), stably replicates in <i>E. coli</i> , <i>B. pseudomallei</i> and <i>B. thailandensis</i> , Tet <sup>R</sup>	(Heeb et al., 2002) (A gift from Dr. Jo Stevens)
pME VacJBT	Complementation vector pME6032 derivative, contains full length <i>bth_i3001</i>	This study
pMEK	pME6032 derivative, Tet <sup>R</sup> cassette replaced with Km <sup>R</sup> cassette from pUT-mini-Tn5 Km2 [76] at the <i>Bam</i> HI and <i>Xba</i> I sites.	This study
pMEK VacJBT	Complementation construct pMEK derivative, contains full length <i>bth_i3001</i>	This study

### 2.3.2 Cell lines and culture conditions

J774A.1 BALB/c murine macrophage cells (ATCC® TIB-67™) and A549 human lung epithelial cells (ATCC® CCL-185™) were routinely cultured in Dulbecco's modified Eagle's medium supplemented with 10 % foetal calf serum (FCS) and F-12K (Kaighn's) medium supplemented with 10 % foetal calf serum respectively. Both cell lines were cultured at 37°C under a humidified atmosphere with 5 % CO<sub>2</sub>.

## 2.4 Bioinformatics tools

### Alignment tools

1. National Centre for Biotechnology Information Basic Local Alignment Search Tool (NCBI BLAST)
  - <http://blast.ncbi.nlm.nih.gov/>
2. The Wellcome Trust *B. pseudomallei* BLAST server
  - [http://www.sanger.ac.uk/cgi-bin/blast/submitblast/b\\_pseudomallei](http://www.sanger.ac.uk/cgi-bin/blast/submitblast/b_pseudomallei)
3. ClustalW : Alignment of protein sequences
  - <http://www.ebi.ac.uk/Tools/msa/clustalw2/>
4. Artemis (release 12.0)
  - <http://www.sanger.ac.uk/resources/software/artemis/>
5. BioEdit
  - <http://www.mbio.ncsu.edu/bioedit/bioedit.html>

### Primer Designing Tool

- <http://www.ncbi.nlm.nih.gov/tools/primer-blast/>

### Prediction of protein characteristics

1. PSORTb version 3 (Yu et al., 2010).
  - <http://www.psort.org/psorb/>
2. Lipoprotein prediction tool (Rahman 2008)
  - <http://www.cbs.dtu.dk/services/LipoP/>
3. DOLOP (Babu 2006)
  - <http://www.mrc-lmb.cam.ac.uk/genomes/dolop/>

## **2.5 Molecular Biology**

### **2.5.1 DNA extraction and purification**

Bacterial genomic DNA was isolated using ArchivePure DNA purification kit (5 Prime, GmbH), and plasmid DNA was isolated from *E. coli* strains using the QIAprep miniprep kit (Qiagen) according to manufacturer's instructions. DNA fragments were purified using the QIAquick gel extraction kit or QIAquick PCR purification kit (Qiagen). DNA quality was assessed using NanoDrop ND-1000 spectrophotometer (NanoDrop Technologies, Wilmington, USA) and by agarose gel electrophoresis.

### **2.5.2 Oligonucleotide primers**

Custom oligonucleotides were synthesized by Life Technologies. Primers used in this study are listed in Tables 2.4 – 2.8.

**Table 2.4 Oligonucleotide primers used for the construction of unmarked in-frame *B. pseudomallei* and *B. thailandensis* mutants.**

Oligonucleotide and sequence (5' to 3') <sup>a</sup>		Target region
VacJ Left Fwd	<u>tttTCTAGAGCAGCCCCGCAAACGGTTG</u>	Left flank of <i>bpsI3147</i>
VacJ Left Rev	CGCAAGCGGCATACGAGAGAAGCGGCGTCGACGGTTCCAAGT	
VacJ Right Fwd	ACTTGGAAACCGTCGACGCCGCTTCTCTCGTATGCCGCTTGCG	Right flank of <i>bpsI3147</i>
VacJ Right Rev	<u>tttTCTAGAGGCGCGTTCTGGTCGCAGAT</u>	
BT_VacJ_F1X	<u>tttctaga</u> CCGCGCTTTTGCGTGCTCTT	Left flank of <i>bth_i3001</i>
BT_VacJ_R1M	acgAGAGAAGAAGCGAGGGGAAGAAACGATTCTGACGGCGGCCG	
BT_VacJ_F2M	CGGCCGCCGTCAGAATCGTTT <u>c</u> TTCCCCTCGCTTCTTCTCTCGT	Right flank of <i>bth_i3001</i>
BT_VacJ_R3X	<u>tttctaga</u> AGCCTTTTCTGGGATGACGATG	
BT_VacJ2_F1X	<u>tttctaga</u> CAAGAACCTGCCGCCGCAGA	Left flank of <i>bth_ii2351</i>
BT_VacJ2_R1M	GGACGATGCGCCGATGAGGCCCGACGCGGTGGTTTCGCAT	
BT_VacJ2_F2M	ATGCGAACCAACCGCTCGGGCCTCATCGGCGCATCGTCC	Right flank of <i>bth_ii2351</i>
BT_VacJ2_R2X	<u>tttctaga</u> CTTCGTCGGCGTCGAGCTCG	

<sup>a</sup>Engineered restriction sites (*Xba*I) are underlined.

**Table 2.5 PCR primers for screening deletion mutant (*B. pseudomallei*)**

PCR	Primer name	Primer sequence (5'-3')
L 3147	BT_VacJ_L	TGACCTGCTTGTGTGAGTCGATGCC
	BT_VacJ_R3X	<u>TTTTCTAGAAGCCTTTTCTGGGATGACGATG</u>
pDM4-3147	pDM4_seqF	TGTGGAATTCCTGGGAGAGCTCA
	VacJ Seq R3	AGGCATCGTGAGCAGCTT
L 3147 LR	BT_VacJ_L	TGACCTGCTTGTGTGAGTCGATGCC
	BT_VacJ_R	CGCGAGCGGCATACGAGAGAAGA
BPSL3146	bpsl3146 F	CACGATGCCTGCTTGCCCGA
	bpsl3146 R	TCCTTGCCGCGCTGTTCTCG
BPSL3147b	bpsl3147 F2	AGGTACGCGTTGCGCACGAA
	bpsl3147 R2	CGACCAAGGGCGACCCGTTC
BPSL3148	bpsl3148 F	CACGATCGCCGACTGCGTCA
	bpsl3148 R	CTCGCGCTGAAGGTCGGCAA

**Table 2.6 PCR Primers for screening deletion mutant (*B. thailandensis*)**

PCR	Primer name	Primer sequence (5'-3')
*pDM4-3001	pDM4_seqF	TGTGGAATTCCTCCGGGAGAGCTCA
	VacJ Seq R3	AGGCATCGTGAGCAGCTT
*I 3001 LR	BT_VacJ_L	TGACCTGCTTGTGTGAGTCGATGCC
	BT_VacJ_R	CGCGAGCGGCATACGAGAGAAGA
#pDM4-2351	pDM4_seqF	TGTGGAATTCCTCCGGGAGAGCTCA
	VacJ2 SeqR2	CGTGATCCACAGCAGCAC
II 2351	II2350_F	CCGATGCGCAGCCGCAAAAAG
	BT_VacJ2_R	ACCGGACGAACGACGGACGATG
#II 2351 LR	BT_VacJ2_L	TCGATGAATAAGATGCGAACCACCGCG
	BT_VacJ2_R	ACCGGACGAACGACGGACGATG
BTH_I3000	3000 F	TGCTGGTTGCGCTCGGTCAG
	3000 R	GACCAGTCGAACCCGCAGGC
BTH_I3001	3001 F	CCGGATGCTCGGCCAATGGA
	bt-3001-UP	CGGTCCAGACGCCGACGAAG
BTH_I3002	3002 F	CAGCATTTCGGTGTGCGCCGC
	3002 R	TCGACAACATCGGCGGCCTG
BTH_II2350	bthii 2350 F	TCTTCTCGTTTCTGCCGACC
	bthii 2350 R	CAGGTTCTTGCGCGTGATTT
BTH_II2351	bthii 2351 F	CGAACAACCTGCTGCAACTC
	bthii 2351 R	TTCGTCTTCGACGGAGCATT
BTH_II2352	bthii 2352 F	GACGAGATTCACGACGACCT
	bthii 2352 R	CCTGAATTCAATCGCGACACC

\* I 3001 MX is a multiplex PCR using primers from pDM4-3001+ I3001 LR.

#II 2351 MX is multiplex PCR using primers from pDM4-2351 and II2351 LR.

**Table 2.7 Other sequencing primers used in this study**

Primer name	Primer sequence (5'-3')
VacJ Seq Fwd	CCTGCTTGTGTGAGTCGATG
VacJ Seq Rev	TGATCGGCCAGTTCCTCTAC
VacJ Seq F2	GCCTGGTAGGTGTTTCGTGTC
VacJ Seq R2	AAGGACATCCTGCCGTACAC
I2998_F	CCGTTTCGGCAGTCCCGCAAA
I3003_R	AAGGCGGCGTCGAAGTGTGG
VacJ2 Seq F2	GTCCGATACCGGCAGAAC
VacJ2 Seq Fwd	ACGAATCAATCGCAAGGAAT
VacJ2 Seq Rev	ATTGCCGTTTCGCGGAGT
I12350_F	CCGATGCGCAGCCGCAAAAG
I12353_R	GGCGGCTCGGGCTTCTTTCA
SP6	ATTTAGGTGACACTATAG
T7	TAATACGACTCACTATAGGG
M13 Fwd (-20)	GTAAAACGACGGCCAGT
pJet1.2 Forward	CRACTCACTATAGGGAGAGCGGC
pJet1.2 Reverse	AAGAACATCGATTTTCCATGGCAG
pDM4 F1	ACGGTTGTGGACAACAAGCCAGG
pDM4 R1	TGCGGGTAACCTGAGCTCTCCC
P6032	CCCTCACTGATCCGCTAGTC
PTAC	CGGCTCGTATAATGTGTGGA



**Table 2.8 Oligonucleotide primers used in making complementation construct for *B. thailandensis***

Primer name	Primer sequence (5'-3')
3001-DN-KpnI	tttggtagcTCAGTGCAGCCGGATGCTCG
3001-UP-ApaI	tttggggcccTACGAGAGAAGAAGCGAGGGGAAG

### 2.5.3 Polymerase chain reaction (PCR)

A typical PCR using *Taq* DNA polymerase (Bioline) contained 1 x MyTaq Reaction Buffer (with 1mM dNTPs, 3 mM MgCl<sub>2</sub>), forward and reverse oligonucleotides (2 pmol/μl), 1.25 U *Taq* DNA polymerase, 0.1 μg genomic DNA or 10 ng plasmid DNA, 8 % (v/v) dimethyl sulphoxide (DMSO) and distilled water to a final volume of 50 μl.

The PCR protocol is shown below.

Typical PCR reaction:

1 cycle

95°C (denaturing) – 1 min

30 cycles

95°C (denaturing) – 15 s

55°C (annealing) – 15 s

72°C (extension) – 15 s

For colony PCR, a single bacterial colony was added to 50 μl dH<sub>2</sub>O and boiled for 10 min. 5 μl boilate was used as the template in a standard PCR.

High-fidelity PCR using Phusion DNA polymerase (Thermo Scientific) contained 1 x Phusion GC buffer (with 0.2 mM dNTPs, 1.5 mM MgCl<sub>2</sub>), forward and reverse oligonucleotides (2 pmol/μl), 0.1 μg genomic DNA, 8 % (v/v) DMSO and distilled water to a final volume of 50 μl.

The PCR protocol is shown below:

Typical high fidelity PCR reaction:

1 cycle

98°C (denaturing) – 30 s

30 cycles

98°C (denaturing) – 10 s

72°C (extension) – 30 s / kb

72°C (final extension) – 5 min

#### **2.5.4 Agarose gel electrophoresis**

PCR products were loaded on 1 % agarose gel (Qbiogene, Cambridge, UK) containing 0.4 μg/ml ethidium bromide (Promega) in a Hybaid gel tank (Thermo Hybaid UK, Ashford, Middlesex) containing 1 x TAE buffer. The electrophoresis was set to run at 100 V, 500 mA. Gels were visualised under ultraviolet (UV) light using a Syngene bio imaging system (Syngene, Cambridge, UK).

### **2.5.5 Restriction enzyme digest**

A typical digest reaction consisted of 1 x restriction enzyme digestion buffer, 1 µg DNA, 6 U restriction enzyme, 2 µg acetylated bovine serum albumin (BSA) and distilled water. The reaction mix was incubated at 37°C for 1 – 4 hours. The digest products were subjected to agarose gel electrophoresis to visualise and purify fragments.

### **2.5.6 Dephosphorylation of vector DNA**

The linearized vector DNA was dephosphorylated by incubating 1 to 5 µg DNA with 5 U Antarctic phosphatase (New England Biolabs) and 1 x Antarctic phosphatase reaction buffer at 37°C for 15 min before heat-inactivating the enzyme at 65°C for 5 min. The product was purified using a PCR purification kit (Qiagen).

### **2.5.7 Ligation**

A typical ligation reaction consisted of 1 x ligation buffer, 3 U T4 DNA ligase (Fermentas), vector DNA (25 ng) and insert DNA at a molar ratio of 1:3. The reaction was incubated at room temperature for 1 h or at 4°C overnight and 1 – 2 µl of the reaction was used in transformation reactions.

### **2.5.8 Preparing electrocompetent *E. coli* cells**

2 ml of overnight culture of *E. coli* was added to 100 ml of LB broth and grown in a 37°C shaker incubator until the optical density (OD<sub>600</sub>) equals 0.4 – 0.6 (log phase growth). Cells were kept at 4°C (or on ice) for the remainder of the procedure. The culture was centrifuged at 4000 rpm for 15 min and the supernatant was discarded. The pellet was washed in ice-cold 10 % glycerol before subjected to centrifugation. The washing step was repeated for two more times. Cells were resuspended in 1 ml of ice-cold 10 % glycerol and aliquoted to pre-chilled 1.5 ml microcentrifuge tubes. 100 µl of electrocompetent cells was used for transformation.

### **2.5.9 Preparing electrocompetent *B. thailandensis* cells**

Electrocompetent *B. thailandensis* were prepared as described in Choi *et al.* (2008) (Choi *et al.*, 2008). Briefly, 6 ml of *B. thailandensis* overnight broth culture was aliquoted into four 1.5 ml microcentrifuge tubes and centrifuged for 2 min at 16,000 x *g* at room temperature. The pellet was washed in 1 ml of 300 mM sucrose solution and subjected to centrifugation for 2 min at 16,000 x *g* at room temperature. The supernatant was discarded and the sucrose wash step was repeated. The washed cell pellets were resuspended in a combined volume of 200 µl of sucrose solution. 100 µl of electrocompetent cells was used for transformation.



Sequencing products were added to a tube containing 80 µl 75 % (v/v) isopropanol and incubated at -20°C for 1 h. Samples were then centrifuged at 13,000 rpm for 30 min and the supernatant was discarded. Samples was washed with 400 µl 75 % (v/v) isopropanol and centrifuged for a further 5 min at 13,000 rpm. The supernatant was removed and the pellet was dried at room temperature for 20 min. 10 µl Hi-Di solution (Applied Biosystems, Cheshire, UK) was applied to the pellet and the reaction mixture sequenced using an ABI3730 DNA Analyzer (Applied Biosystems). DNA sequence data was visualized using Chromas version 1.61 software (Technelysium Pty Ltd, Australia) and analysed using NCBI BLAST, ClustalW and BioEdit.

#### **2.5.12 RNA extraction**

Bacterial RNA was isolated using RNAProtect® bacteria reagent (Qiagen) and TRI Reagent® solution (Sigma-Aldrich) according to manufacturer's instructions. 1.5 µg of RNA was treated with AMBION TURBO DNase® according to manufacturer's instructions.

#### **2.5.13 Reverse transcription PCR**

DNase treated RNA was then reverse transcribed into cDNA using random hexamers and Invitrogen Superscript III first strand synthesis kit according to manufacturer's instructions and cycling conditions. Synthesised cDNA was stored at - 20°C until needed for PCR reaction.

#### **2.5.14 Sodium dodecyl sulphate polyacrylamide gel electrophoresis (SDS-PAGE)**

Bacterial lysates were boiled at 100°C for 30 min and mixed with sample loading buffer. Samples and the PageRuler Plus Prestained Protein ladder 10-250K (Thermo Scientific) were loaded onto 10 % Bis-Tris gels set up in a XCell Mini-cell electrophoresis system containing 1 x MOPS SDS running buffer (Life technologies). Gels were run at 150 V for 1 h 30 min.

#### **2.5.15 Polyacrylamide protein gel staining**

The polyacrylamide gels were incubated with Coomassie stain for 1 h with agitation, followed by rinsing with destain solution for 1 h. Destain solution was re-applied three times. Coomassie gels were visualized on an Odyssey® CLx infrared imaging system (LI-COR) using the 800 nm LI-COR channel.

#### **2.5.16 Western blot**

Separated proteins were transferred from the polyacrylamide gel to a Hybond-C extra nitrocellulose membrane (GE Healthcare) with transfer buffer (Appendix 1), using the Hoefer SemiPhor System (GE Healthcare) set at 45 mA for 1.5 h (or 90 mA for two gels).

The nitrocellulose membrane was blocked with 2 % skimmed milk (Tesco, Cheshunt, UK) in PBST (blocking buffer) for 1 h at room temperature with agitation at 75 rpm (Platform shaker STR6, VWR-Jencons) or overnight at

4°C. The membrane was incubated with 1:1000 dilution monoclonal anti-LPS (CC6) in blocking buffer for 1 h with agitation, and then washed four times for 5 min with PBST. The membrane was incubated with 1:5000 dilution IRDye 800CW anti-mouse IgG (H+L) secondary antibody (Li-Cor) for 1 h with agitation and then washed four times for 5 min with PBST. A final wash in PBS was included. Fluorescence on the membrane was detected using the Odyssey® CLx infrared imaging system (LI-COR).

## **2.6 Mutant construction and characterization**

### **2.6.1 Cloning**

Splicing by overlapping extension PCR (SOE PCR) was performed for the gene targeted for in-frame deletion (Heckman and Pease, 2007). Intermediate segments (the flanks of the target gene) were first amplified, and then used as template in a subsequent PCR to generate a full length, spliced product.

Inner primers were designed to encode 20 nucleotides found at the junction of the adjoining segment. Approximately 600 to 1200 bp flanking regions of the target gene was first amplified from purified genomic DNA by PCR using Phusion High-Fidelity PCR master mix (Thermo Scientific) according manufacturer's instructions. These intermediate amplicons contain overlapping regions that hybridize at the 3' end. 1 µl of the amplicons were used as template in a subsequent PCR with flanking primers that introduce a *Xba*I restriction site for cloning purposes. The assembled amplicon contains spliced regions of the flanks of the target gene.



The spliced amplicon was subjected to agarose gel electrophoresis, purified using a gel purification kit (Qiagen) and cloned into pJet1.2/Blunt vector (Fermentas) in *E. coli* Top10 cells according to manufacturer's instructions. The constructs were digested using the restriction enzyme corresponding to the engineered restriction site on the primer pair. The desired DNA fragment was cloned into the suicide vector pDM4 in *E. coli* EC100D pir+ and subsequently *E. coli* MFD to obtain the deletion construct. The clones were screened by PCR and sequencing.

### **2.6.2 Conjugation**

The deletion construct was delivered via conjugation into *B. pseudomallei* or *B. thailandensis*. Overnight cultures of the donor strain harbouring the pDM4 deletion construct and the recipient strain (*B. pseudomallei* K96243 or *B. thailandensis* E264) were mixed in a 1:3 volume ratio respectively. 100 µl of the mixture was applied to a prewarmed LB plate and incubated overnight at 37°C. Cells were resuspended in PBS and cultured overnight at 37°C on LB plates containing appropriate antibiotics. Integrants (merodiploids) were confirmed by colony PCR.

### **2.6.3 Sucrose selection**

A single integrant colony (merodiploid) was used to inoculate 10 ml LB broth and incubated at 37°C overnight with agitation. The overnight culture was diluted in PBS and 100 µl was plated on sucrose agar (Logue et al., 2009). The plate was incubated at 24°C for 48 h or until colonies were well grown. Colonies were screened for sensitivity to chloroamphenicol (Cm), which indicates that the suicide vector, pDM4, has been excised from the genome by a second recombination event. Cm-sensitive colonies were screened using PCR and sequencing to confirm the deletion of the target gene.

### **2.6.4 Complementation**

The full length gene *bth\_i3001* was amplified from *B. thailandensis* E264 genomic DNA respectively by PCR (Table 2.8) and cloned into the vector pME6032 or pMEK to generate pMEVacJBT and pMEKVacJBT respectively. The plasmid was introduced into *B. thailandensis* E264 VacJ mutants by electroporation transformation. Conjugates were screened by colony PCR. The complemented mutant strains were grown in LB broth containing appropriate antibiotics and 1 mM IPTG.

## **2.7 *In vitro* assays**

### **2.7.1 Growth curves**

2 ml of overnight broth culture was added to 100 ml LB broth and incubated at 37°C. At various time points, 1 ml bacterial culture was removed and

absorbance at 600 nm read using a Biochrom WPA CO8000 cell density meter (Biochrom). Alternatively, the bacterial culture was serially diluted and plated onto LB agar and incubated at 37°C overnight.

### **2.7.2 Antimicrobial sensitivity assay**

An *in vitro* susceptibility testing was performed by a standard broth microdilution method. Briefly, microtiter plates containing twofold serial dilutions of antibiotics in cation-adjusted Mueller-Hinton broth (Becton Dickinson, Cockeysville, Md.) were inoculated with the appropriate dilution of a log-phase culture. Viable counts were determined immediately after inoculation to verify that the actual inoculum size was between  $10^5$  and  $10^6$  CFU/ml. The plates were incubated at 37°C for 24 h. The MIC was defined as the lowest concentration of antibiotic that completely inhibited visible growth for 24 h.

### **2.7.3 Growth inhibition assays in SDS or EDTA**

Bacterial cultures were grown overnight in LB broth at 37°C, washed and diluted to about  $1 \times 10^7$  CFU/ml in PBS. This was added to a 96-well microtiter dish in triplicates, and 10-fold dilutions were prepared in PBS. 10  $\mu$ l of bacterial culture was transferred from the dish to LB agar with or without SDS or EDTA at the indicated concentrations. Colonies were counted after 2 days of incubation at 37°C.

#### **2.7.4 Adhesion assay**

A549 cells were seeded at a density of  $5 \times 10^5$  cells/ml in 24-well plates and incubated overnight at 37°C with 5 % CO<sub>2</sub>. An overnight culture of bacteria was pelleted and diluted in the culture medium. 1 ml bacterial culture was added to the cells to achieve a multiplicity of infection (MOI) of 5. At appropriate time points, the cells were washed four times with PBS and lysed in 0.1 % Triton X-100 for five minutes, serially diluted and plated onto LB agar plates.

#### **2.7.5 Intracellular survival assay**

*Burkholderia* uptake and survival were quantified utilizing a modified kanamycin protection assay (Wand et al., 2011). J774A.1 cells were seeded at a density of  $1 \times 10^5$  cells/ml in 24-well plates and incubated overnight at 37°C with 5 % CO<sub>2</sub>. An overnight culture of bacteria was pelleted and diluted in the corresponding culture medium for the cell line to be infected. 1 ml bacterial culture was added to the cells to achieve a multiplicity of infection (MOI) of 10 or 1. The cells were incubated at 37°C for 1 h to allow bacterial internalisation to occur. Cells were washed with PBS and 1 ml of culture medium containing 250 µg/ml kanamycin was added to kill extracellular bacteria. At appropriate time points, cells were washed with PBS and lysed in 0.1% Triton X-100 in PBS for 5 minutes, serially diluted and plated onto LB agar plates and incubated overnight at 37°C.

### 2.7.6 Immunofluorescence

J774A.1 macrophages grown on glass coverslips placed at the bottom of 24-well plates were infected with *Burkholderia* strains as already described. At appropriate time points, cells were washed three times with PBS and fixed with 4% paraformaldehyde for 15 minutes at room temperature. Cells were washed three times with PBS before permeablizing the cells with 0.5% Triton X-100 in PBS for 15 minutes at room temperature. After three more washes in PBS, cells were incubated with 5% (vol/vol) FCS in PBS for 1 h at room temperature. After washing the cells in PBS, coverslips were incubated with a monoclonal antibody that binds to *Burkholderia* LPS (CC6, DSTL, 1:1000 dilution), and a primary antibody appropriate for the assay (LAMP-1: rat anti-LAMP-1 antibody (1D4B, Molecular probes, 1:500 dilution); LC3b: rabbit anti-LC3b antibody (Molecular probes, 1:500 dilution)) for 1 h at room temperature. Following three washes in PBS, cells were incubated with Alexafluor488-conjugated anti-mouse antibody (Molecular probes, 1:1000 dilution) and the appropriate secondary antibodies for 1 h at room temperature. After several washes in PBS, coverslips were mounted onto microscopy slides using DPX mounting medium (dibutyl phthalate xylene, Merck). Samples were analysed using a ZEISS LSM510 confocal-laser scanning microscope or a CCD fluorescence microscope (Axioplan 2 upright microscope).

For visualization of actin polymerization, infected cells were stained as described above without the use of primary antibodies for mammalian markers. The cells were then incubated with Alexafluor555-phalloidin conjugate solution (binds F-actin, Molecular probes, 1:50 dilution) and the

appropriate secondary antibody for 1 h at room temperature. After several washes in PBS, cells were stained with 300 nM 4'6-diamidino-2-phenylindole (DAPI, Life Technologies) according to manufacturer's instructions.

### **2.7.7 Giemsa staining of MNGCs**

J774A.1 macrophages were infected as already described. At appropriate time points, cells were washed with PBS and treated with 100 % methanol for 30 minutes at room temperature. Cells were thoroughly washed with PBS and stained with Giemsa solution for 30 minutes at room temperature. After washing with PBS, cells were allowed to dry before being visualised under a light microscope.

## **2.8 *In vivo* studies**

All mouse challenge studies were carried out by Dr. Natasha Spink and Dr. Bea Choi. I prepared inocula for the challenge studies and homogenised all organs following collection for bacterial counting purposes. Groups of 6 female BALB/c age-matched mice (Charles River Laboratories, UK) were housed together with free access to food and water and subjected to a 12 h light/dark cycle. All animal experiments were performed in accordance with Animals (Scientific Procedures) Act 1986 and were approved by local Ethical Review Committee.

### **2.8.1 Mice infection model**

For intranasal (i.n.) inoculation, mice were anaesthetised with a combination of 5 mg/ml Ketamine (Ketaset, Fort Dodge Animal Health Ltd), and 1 mg/ml Xylazine (Rompum, Bayer), in pyrogen free saline. This dose is based on the i.p. administration of 200 µl to a 20 g mouse and to ensure the safety and efficiency of the anaesthetic, mice were weighed and the volume given adjusted accordingly. When under anaesthetic, the mice were restrained and dosed by slowly pipetting the 50 µl inoculum into both nostrils. Following inoculation, mice were held upright for further 30 seconds to allow liquid to drain into lungs. Mice were monitored twice daily for signs of morbidity and mortality.

To investigate organ load burdens following infection with *B. pseudomallei*, organs were homogenised by pressing through a 70 µm mesh cell-strainer (Falcon, Becton Dickinson, Oxford, UK) with the plunger from a 2 ml syringe (Becton Dickinson). Serial 10-fold dilutions of the resulting cell suspensions were plated onto LB agar plates and viable colonies counted after 48 h incubation at 37°C. Following cardiac puncture, blood was collected from mice in tubes containing with 0.1 ml heparin. Serial 10-fold dilutions of blood samples were plated on LB agar and bacterial counts were normalized to colony forming units / ml blood.

### **2.8.2 Protection studies**

Mice were immunized i.n. with the K96243 BPSL3147 mutant or the 7A1 at doses of 500 CFU. Animal survival was monitored for 45 days.

Surviving vaccinated mice or six naïve controls were then challenged i.n. with 500 CFU *B. pseudomallei* K96243 and survival was monitored on a daily basis.

### **2.9 Statistical Analysis**

Statistical analyses were performed using GraphPad Prism version 6.04 (GraphPad Software, San Diego California USA).

For *in vivo* mutant characterization, a Log-rank (Mantel-Cox) Test was used for comparison of survival curves and the Mann-Whitney test was used for determining bacterial load in organs. The two-way ANOVA and Bonferroni's post-test or the unpaired Student's *t*-test was used for intracellular survival assays, MNGC formation assays, serum survival assays.

A *p* value of less than 0.05 was reported as statistically significant (\*  $p < 0.05$ ; \*\*  $p < 0.01$ ; \*\*\*  $p < 0.001$ ).



### **3. Chapter 3 – Identification and characterization of *B. pseudomallei* VacJ**

#### **3.1 Introduction**

Novel functional genetic analysis tools that allow large-scale screening of bacterial transposon mutant libraries are shifting the paradigm for identifying genes that are essential for growth or virulence and for detecting novel antimicrobial targets or potential vaccine candidates (Langridge et al., 2009). The goal is to obtain a system-level understanding of the functional aspects of biological systems, in this instance, of various genes and regulatory networks involved in infection of the host (Opperman et al., 2003). Signature-tagged mutagenesis (STM) is a negative selection tool that is used to identify virulence associated genes through phenotypic analysis of virulence in animal models (Hensel et al., 1995). For example, it can be used for high throughput screening of virulence genes associated with pathogen colonization or survival in animal models (Atkins et al., 2002a, Cuccui et al., 2007). Briefly, animals are infected with pools of tagged transposon mutants (input pool) and individual mutants which are absent or underrepresented in the infected animals (output pool) due to an inability to survive, grow, or disseminate can be identified based on their individual signature tags by comparing the input and output pools. These negatively selected mutants are considered to be attenuated and are inferred to lack functionality of a gene required for colonization or survival. A variety of biochemical and genetic *in vitro* and *in vivo* methods may then be used to elucidate and confirm the functions of these genes.

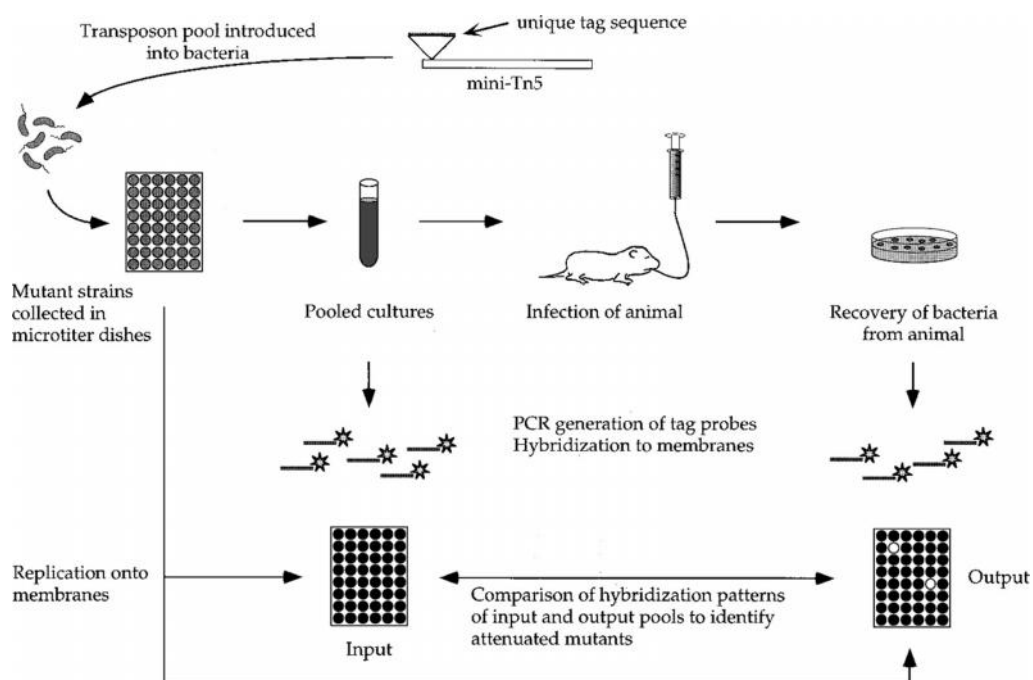

**Figure 3.1 Schematic representation of the original STM strategy**

(Reproduced from (Chiang et al., 1999))

STM has its limitations. For example, the size of mutant pools are limited by the number of unique tags required constructing libraries and generally only the most strongly attenuated mutants are identified. In addition, the insertion site of each transposon must be determined individually through arbitrary PCR, which is unreliable and time consuming. Recently, a novel technology known as transposon-directed insertion-site sequencing (TraDIS) has improved our ability to analyse larger pools of transposon mutants by exploiting Illumina sequencing technology to obtain the sequence flanking each transposon insertion (Langridge et al., 2009). This method allows for a simultaneous sequencing from a very large pool of mutants that provides coverage of the entire genome. It has been used to define essential genes and novel targets for antimicrobial development for *Salmonella enterica* serovar Typhi (Langridge et al., 2009), *S. pneumonia* (van Opijnen and

Camilli, 2010), *B. pseudomallei* (Moule et al., 2014) and *B. thailandensis* (Baugh et al., 2013).

TraDIS can also be used as a negative screening method to identify genes that are associated with various environment stresses or infection in animal models (Eckert et al., 2011). In addition to providing the genotype of the mutants, TraDIS provides a numerical measurement of the fitness score (log<sub>2</sub> fold change) of the mutants through the comparison of the number of specific sequencing reads derived from input and output pools. In one application, TraDIS was applied retrospectively to sequence *E. coli* STM library screened in cattle, validating and extending the analysis of the STM mutants by giving information on every mutant and identifying hundreds of additional novel genes that are potentially involved in infection of cattle and intestinal colonization (Eckert et al., 2011).

Recently, a number of genes likely to be important for growth and survival of *B. pseudomallei* in an *in vivo* mouse model were identified using signature-tagged mutagenesis (Atkins et al., 2002a, Cuccui et al., 2007). A separate study using TraDIS to resequence the *B. pseudomallei* STM library was performed and provided confirmation of these genes and large-scale identification of new genes involved in virulence in mice (Moule and Cuccui, unpublished data). Mutants defective in *aroB* (*bpsI3168*) and *wcbC* (*bpsI2807*) were initially identified in the STM study and were shown to display total attenuation of virulence and were cleared from the lungs and spleens in infected mice (Cuccui et al., 2007). This was confirmed in the TraDIS experiment and correlated to fitness score (log<sub>2</sub> fold change) > - 1.6

in both mutants extracted from both lungs and spleen in the TraDIS experiments (Table 3.1).

Among the novel genes identified through both the original *B. pseudomallei* STM screen performed in Cuccui *et al.* (2007) and the later TraDIS screen (Moule, unpublished data), a putative outer membrane lipoprotein encoded by *bps/3147* appeared to be important for *in vivo* virulence as evidenced by the low fitness score of the corresponding mutant 7A1, particularly in spleen samples. The gene *bps/3147* is located in *B. pseudomallei* K96243 chromosome 1 and encodes a putative lipoprotein VacJ. Bioinformatic analyses and comparisons with the relatively avirulent *B. thailandensis* were conducted to generate hypothesised roles for this putative lipoprotein and virulence factor.

**Table 3.1 Selected examples of a retrospective TraDIS investigation of STM mutants.**

Disrupted genes and their putative functions are listed, along with the number of observed TraDIS reads for the gene in each sample (pre-infection: input pool; post-infection: organ). The brackets indicate the log<sub>2</sub> fold change relative to the input to represent the difference in abundance of each mutant in the organs relative to the input. (Moule, unpublished data)

Gene	Putative function	Observed reads in sample (log <sub>2</sub> fold change relative to input)				
		Input pool	Lung 1	Lung 2	Spleen 1	Spleen 2
<i>bps/3147</i> ( <i>vacJ</i> )	Lipoprotein VacJ	12632	905 (-1.884)	752 (-2.016)	6 (-5.259)	1 (-6.234)
<i>bps/3168</i> ( <i>aroB</i> )	Dehydroquinate synthase	11123	32 (-4.105)	8 (-4.993)	3 (-5.569)	0 (-7.728)
<i>bps/2807</i> ( <i>wcbC</i> )	Outer membrane transporter	81918	7870 (-1.686)	1613 (-2.819)	134 (-4.571)	3 (-7.007)
<i>bps/2808</i> ( <i>wcbB</i> )	Capsular polysaccharide glycosyltransferase biosynthesis protein	41860	10418 (1.000)	11463 (0.932)	65 (4.583)	0 (8.681)

## 3.2 Aims

The aim of this chapter is to identify and characterize putative VacJ (MlaA) lipoproteins in *B. pseudomallei* and the closely related *B. thailandensis* species. Bioinformatics tools were used for the identification of similar genes and for the characterization of protein sequences. The amino acid sequences of VacJ homologues in *Burkholderia* species as well as other bacterial species were compared.

## 3.3 Results

### 3.3.1 Bioinformatic analysis of *bpsl3147*

The gene *bpsl3147* is predicted to encode an outer membrane lipoprotein VacJ based on BLASTP and Psort analysis. The N-terminal contains the characteristic lipoprotein signal sequence, (a n-region with positively charged amino acids in the initial residues, a hydrophobic h-region with 7 to 22 predominantly hydrophobic and uncharged residues, and a lipobox [LVI][ASTVI][ASG]C), where cleavage and lipid modification typically occurs at the invariant cysteine residue of the lipobox (Figure 3.2).

n region	h region	Lipobox
MNAQAAYERRKEGKNIMQTI	RS	PAVLAITAAAALSGC
ATVQTPTKGDPEFEGFNRTMYTFNDKVDQYALKPVARGY		
QWAVPQPMRDSVTNFFSNIGDVYIAANNLVQLKIADGV		
GDIRVVINTVFGVGGFLFDVATLAKLPKHANDFGVTLGH		
YGVPSGPYLVLPLLLGPSTVRDTAGLAVDYAGNPLTYVVRP		
DGVSWGLFGLNLVNTRANLLGAGDVLEAAAIDKYSFVR		
NAYLQRRQALIGGATGAQSNLPDYGSEAPPPNYEMPEE		
GAAAPASGAASAPAAASAPTAASGAAPGAAEPASAAAP		
NPSSATNVPAQQVPPSPGGIRFPSIRLH		

**Figure 3.2 Amino acid sequence of BPSL3147 in *B. pseudomallei* K96243 contains a typical lipoprotein signal peptide sequence.**

The N-terminal consists of an n-region with positively charged amino acids, a hydrophobic region (h region) and a lipobox sequence.

BLASTP and Pfam analysis showed that BPSL3147 is related to the VacJ superfamily (cl01073) of surface lipoproteins which are associated with cell envelope biogenesis (COG2853) and a provisional ABC transporter outer membrane lipoprotein (PRK15091). VacJ orthologues are found in all *Burkholderia* species (with publicly available genomes) and many Gram-negative bacteria (Table 3.2). VacJ products have also been found in the outer membrane (OM) proteome of *B. pseudomallei* and *B. mallei* (Schell et al., 2011)

Highly conserved orthologues of *bpsI3147* are found in chromosome 1 of the closely related *Burkholderia* species *B. mallei* (*bma2723*) and *B. thailandensis* (*bth\_i3001*), where the respective gene products have 99 % and 94 % amino acid identities. A homologue of the gene is found in chromosome 2 of *B. pseudomallei* and closely related *Burkholderia* strains (*B. pseudomallei*, *B. mallei*, *B. thailandensis* and *Burkholderia oklahomensis*), with the gene products having 46 to 51 % amino acid identity to BPSL3147. It is unclear if the *vacJ* homologue in chromosome 2 is a paralogue (where the genes are related by duplication within a genome) or a xenologue (where the gene is acquired by horizontal gene transfer). The signal sequence of the VacJ homologue encoded by *bpss2331* (chromosome 2) contains an alanine residue instead of a typical [LVI] residue at the -3 position of the predicted lipobox region. Although the predicted products of both VacJ homologues within a *Burkholderia* species only have about 46 % - 50 % amino acid identity to each other, these gene products are highly conserved between *B. pseudomallei*, *B. mallei*, *B. thailandensis* and *B. oklahomensis* (Table 3.2).

However, a study by Sim *et al.* (2008) revealed that novel indels are present in the region surrounding the *vacJ* homologue in chromosome 2 (*bpss2331-bpss2333*) in at least 3 out of 94 Southeast Asian *B. pseudomallei* strains, indicating this region may be part of the accessory genome of *B. pseudomallei* (Sim *et al.*, 2008).

A comparison of the BPSL3147 amino acid sequence against the NCBI nonredundant protein database found significant similarity (29 % to 40 % amino acid identity) to the VacJ lipoprotein in a number of bacterial species, including *S. flexneri*, *H. influenzae*, *E. coli* and the plant pathogen, *Ralstonia solanacearum* (Table 3.2, Figure 3.3).



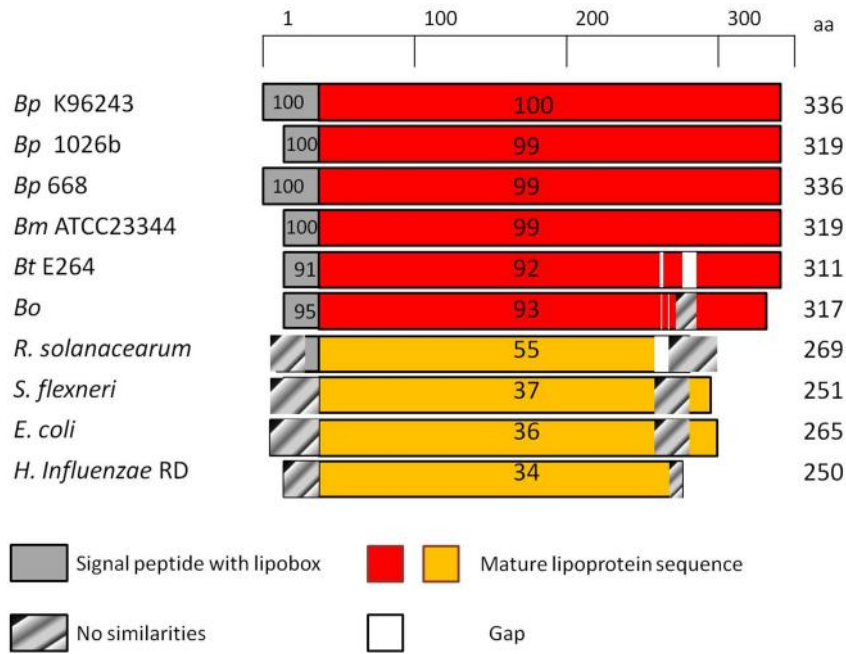

**Figure 3.3 BLASTP alignment of VacJ protein sequences, showing percent amino acid identity between different strains.**

(*Bp*: *B. pseudomallei*, *Bm*: *B. mallei*, *Bt*: *B. thailandensis*, *Bo*: *B. oklahomensis*). Grey box denotes the amino-terminal region with the predicted signal peptide sequence (contains lipobox). The boundary for the signal peptide is based on the amino acid sequence analysis using Psortb and LipoP. Red (above 60% amino acid identity) or yellow (below 60% amino acid identity) regions denote predicted mature lipoprotein sequence. Striped regions represent protein regions with no similarities. The numbers displayed within each coding region represent the percent sequence identity compared to the BPSL3147 coding sequence.

**Table 3.2 Family of VacJ orthologues**

Organism	Gene product or locus tag	Description	% amino acid similarity to BPSL3147	Reference
<i>B. pseudomallei</i>	BPSL3147	Putative lipoprotein VacJ, virulence factor found in purified outer membrane preparation	100 %	(Cuccui et al., 2007, Schell et al., 2011)
<i>B. pseudomallei</i>	BPSS2331	Putative lipoprotein VacJ, found in purified outer membrane preparation, cross reactive antigen that reacts with sera from healthy individuals and melioidosis patients	51 %	(Schell et al., 2011, Felgner et al., 2009)
<i>B. mallei</i>	BMA2723	Putative lipoprotein VacJ, found in purified outer membrane preparation	99 %	(Schell et al., 2011)
<i>B. mallei</i>	BMAA2092	Putative lipoprotein VacJ, found in purified outer membrane preparation	49 %	(Schell et al., 2011)
<i>B. thailandensis</i>	BTH_I3001	Putative lipoprotein VacJ	92 %	
<i>B. thailandensis</i>	BTH_II2351	Putative lipoprotein VacJ	47 %	
<i>B. oklahomensis</i>	WP_010106884	Putative lipoprotein	94 %	
<i>B. oklahomensis</i>	WP_010110855	Putative lipoprotein	46 %	
<i>S. flexneri</i>	VacJ	Lipoprotein exposed on cell surface (virulence-associated chromosome locus J); role in intercellular spreading	38 %	(Suzuki et al., 1994, Carpenter et al., 2014)
<i>E. coli</i>	MlaA	Predicted outer membrane lipoprotein, part of the Mla transport system involved in maintenance of outer membrane lipid asymmetry	37 %	(Malinverni and Silhavy, 2009)
<i>H. influenzae</i>	VacJ	Putative lipoprotein; contributes to outer membrane stability and serum resistance in nontypeable strains (NTHi) by limiting binding of antibody to exposed lipooligosaccharides (LOS)	35 %	(Nakamura et al., 2011)
<i>R. solanacearum</i>	RSc2959	Putative lipoprotein.	53 %	

### 3.3.2 Predicted roles of VacJ

The VacJ (virulence-associated chromosomal locus J) superfamily of proteins was first identified in the intracellular bacterium *S. flexneri* and shown to be important for intercellular spread (Suzuki et al., 1994, Carpenter et al., 2014). The gene product is a 251-amino acid lipoprotein with a predicted molecular mass of 28 kDa that is synthesized as a prolipoprotein. The prolipoprotein is then processed into a mature lipoprotein, secreted into the outer membrane and exposed on the bacterial surface. Mutation of this gene did not affect early steps in pathogenesis. A *S. flexneri vacJ* mutant was found to be capable of forming bacterium-containing membranous protrusions in epithelial cells but had diminished ability to move from the protrusions into adjacent cells (Suzuki et al., 1994).

More recent studies revealed that VacJ orthologues are found in many Gram-negative bacteria and are occasionally interspersed with genes associated with membrane transport (Casali and Riley, 2007) and virulence (Nakamura et al., 2011). In *E. coli*, the gene product (VacJ/MlaA) is part of the maintenance of lipid asymmetry (mla) ATP-binding cassette (ABC) transport system that actively prevents phospholipid accumulation at the cell surface in the absence of obvious extracellular stress (Malinverni and Silhavy, 2009) (Figure 3.4), contributing to outer membrane stability. Core components of the Mla transport system include MlaA (VacJ), MlaB (YrbB), MlaC (YrbC), MlaD (YrbD), MlaE (YrbE) and MlaF (YrbF). Predicted functions of each component are as follows (Malinverni 2009): MlaA is a predicted OM lipoprotein, MlaB is a predicted cytoplasmic protein with a STAS domain, MlaC is a predicted substrate binding protein that resides in

the periplasm, MlaD is a putative substrate-binding protein, and localizes to the periplasmic face of the inner membrane (IM) by an uncleaved sequence. MlaE is an integral IM protein and predicted permease with a signature typically found in ABC import pathways. Finally, MlaF is a classic ABC transport nucleobinding component. In Gram-negative bacteria, the genes encoding these factors are often colocalized, and occasionally interspersed with *mlaA* (*vacJ*) (Malinverni and Silhavy, 2009). In *E. coli*, *mlaA* is not genetically linked to the *mlaF-B* locus. A study on protein-protein interactions using His-tagged *E. coli* ORF clone library revealed that MlaA interacts with the 60 kDa chaperonin encoded by *groL* (Arifuzzaman et al., 2006). In *H. influenzae*, VacJ was shown to act in concert with the Yrb (Mla) ABC transporter proteins to maintain the outer membrane stability and limit binding of antibodies to LOS components, contributing to serum resistance in non-typeable *H. influenzae* (acapsular) (Nakamura et al., 2011). To date, there is no information on the function of VacJ in the plant pathogen *R. solanacearum*.

Bioinformatic analysis of the genes surrounding *bpsI3147* in the *B. pseudomallei* K96243 genome revealed orthologues of all genes involved in the proposed Mla pathway except for *mlaB*, a gene encoding for a cytoplasmic protein with an STAS domain. The putative gene product of *bpsI3145* did not share homology to that of *mlaB* but contains an STAS domain (Figure 3.5). The organization of the *mla* locus is preserved around *bth\_i3001* in *B. thailandensis*. In comparison, the genes surrounding the *vacJ* homologue in chromosome 2 of *B. pseudomallei* and *B. thailandensis* do not display similarity to the genes from the Mla pathway.

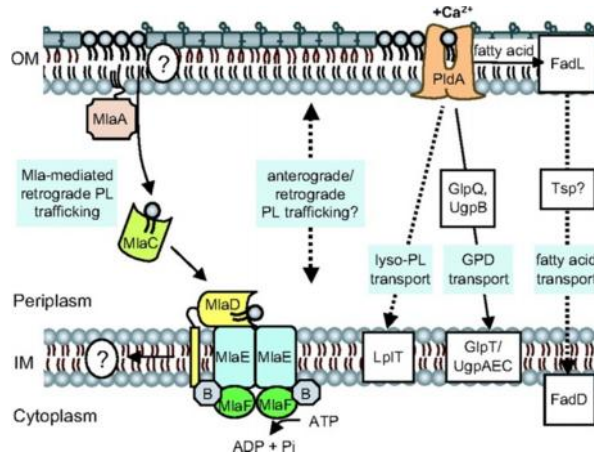

**Figure 3.4 Model of the Mia and PldA PL turnover pathways**  
(Reproduced from (Malinverni and Silhavy, 2009))

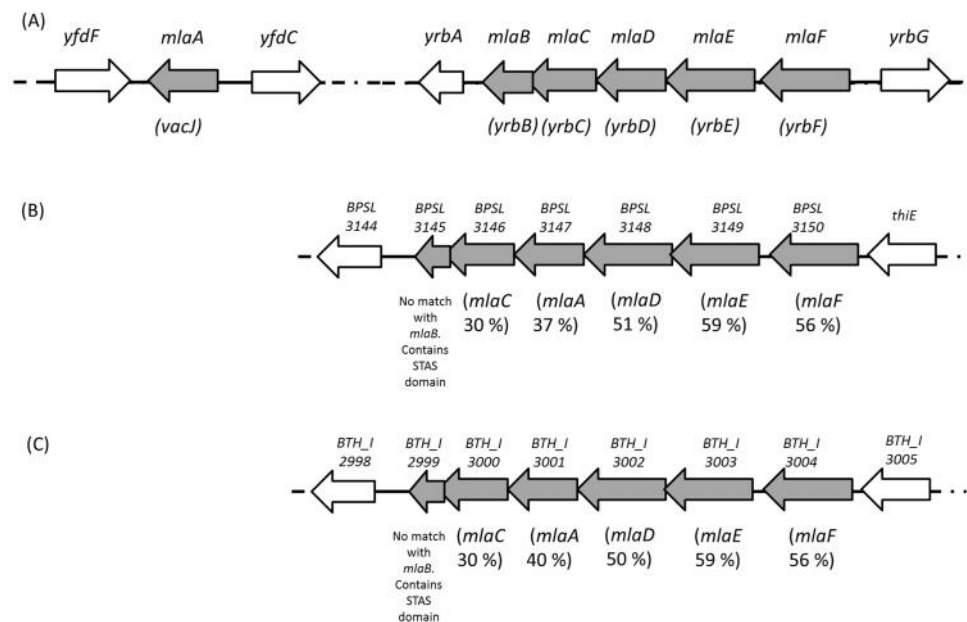

**Figure 3.5 Gene organization of the Mia transport system.**

Genes related to the Mia transport system in A) *E. coli*, B) *B. pseudomallei* K96243 and C) *B. thailandensis* E264 are highlighted in grey. Percentages of amino acid identities are indicated.

### 3.4 Discussion

Since *bps/3147* was first identified in a screen for genes related to *in vivo* virulence, this study focused on confirming this role, and further characterizing the gene and associated genes to increase understanding of *B. pseudomallei* pathogenesis. In a recent study, a dual function of maintenance of OM asymmetry and intercellular spread was proposed for the Mla system (*VacJ/Vps*) in *S. flexneri* (Carpenter et al., 2014). To date, it is unclear if retrograde transport of phospholipids mediates downstream signalling functions that are critical to the persistence of host infection, or whether this maintenance of OM asymmetry affects other bacterial factors. It is possible that alterations to the OM may inhibit the primary virulence factor, thus indirectly altering virulence characteristics. For example, the T3SS is required for the escape of *S. flexneri* from the intracellular double membrane vacuole during infection (Schuch and Maurelli, 1999). Outer membrane defects may affect proper assembly of T3SS in the membrane or secretion of the T3SS effectors (Schuch and Maurelli, 1999, Carpenter et al., 2014). Characterizing the *vacJ* gene in *B. pseudomallei* and *B. thailandensis* may help elucidate novel roles in the intracellular lifecycle of the bacteria.

The identification of the Mla pathway in *E. coli* presents an additional model by which Gram-negative bacteria may maintain the OM integrity. In Gram-negative bacteria, maintenance of the OM integrity is critical for protection against toxic substances and harsh environments. The LPS contributes to the barrier function of the OM and has been shown to protect the bacteria from deleterious agents such as complement (Nikaido, 2003, DeShazer et al., 1998). Disturbances to the OM such as assembly defects, exposure to

antimicrobial peptides, or chelating agents (EDTA), could lead to shedding of the LPS. It is conceivable that without the LPS, other epitopes on the cell surface may become accessible to host immune molecules such as the complement factors that forms membrane attack complex for bactericidal activity (Feingold et al., 1968). Phospholipids from the inner leaflet are forced to migrate to the breached areas of the outer leaflet, resulting in the formation of phospholipid bilayer patches and a reduction in the barrier function. This in turn, could have pleiotropic deleterious effects if the bacteria is unable to compensate for this defect. For example, disruption in the OM could lead to decreased resistance in serum, or may change the presentation of cell surface antigens, and lead to differential host immune responses that may affect bacterial viability. Given the sequence similarity of *bpsl3147* to other *vacJ/mlaA* orthologues and the co-localization of the gene with other members of the *mia* pathway, I postulate that BPSL3147 may play similar roles in *B. pseudomallei*. The presence of a *vacJ* homologue in chromosome 2, albeit as part of the accessory genome, may indicate a functional redundancy of this gene in relation to microbial adaption and virulence.

In *B. pseudomallei*, the presence of a polysaccharide capsule may limit access of molecules to the cell membrane (Roberts, 1996). It would thus be interesting to characterise VacJ in an acapsular strain, or in *B. thailandensis* strains which do not express a polysaccharide capsule for comparison. I hypothesize that VacJ may contribute to *Burkholderia* virulence through a role in outer membrane stability and/or serum resistance, and also possibly through a role in intracellular spread as has been observed in *S. flexneri*.

## 4. Chapter 4 - Characterizing the role of VacJ in *B. pseudomallei*

### 4.1 Introduction

The ability of *B. pseudomallei* to cause disease in humans involves a complex series of events in which the bacteria persist and evade immune responses in the host environment (e.g. blood), invade and replicate within host cells, and spread to adjacent cells causing multinucleated giant cell formation and cellular damage. Virulence factors that contribute to *B. pseudomallei* survival and pathogenesis in mammalian hosts have been identified but it is likely that a multitude of additional factors that contribute to these roles remain to be discovered (Reckseidler et al., 2001, Atkins et al., 2002a, Atkins et al., 2002b, Reckseidler-Zenteno et al., 2005, Cuccui et al., 2007, Wikraiphat et al., 2009, Warawa et al., 2009).

The main aim of this chapter was to evaluate the role of BPSL3147 (VacJ), a putative virulence determinant of *B. pseudomallei*, which was selected from a signature-tagged mutagenesis screen for *in vivo* virulence. The prototypic VacJ was first identified as a 30 kDa lipoprotein in *S. flexneri* that contributes to intercellular spread (Suzuki et al., 1994) and was later found to affect outer membrane asymmetry in *E. coli* and *H. influenzae* (Malinverni and Silhavy, 2009, Nakamura et al., 2011).

In order to demonstrate a specific role for VacJ *in vivo* virulence and *in vitro* functions, defined mutants were created in a clinical *B. pseudomallei* isolate, K96243, through in-frame deletion mutagenesis. This isolate is a fully-sequenced and annotated reference strain. A range of phenotypic assays were used to characterize the mutants and define roles for this gene.



## 4.2 Aims:

1. To generate unmarked, in frame deletions in *B. pseudomallei* K96243
2. To characterize the resulting mutants using *in vivo* and *in vitro* methods.

## 4.3 Results

### 4.3.1 Unmarked in-frame deletion mutagenesis of *bpsI3147* in *B. pseudomallei*

#### 4.3.1.1 Production of a deletion construct

The cloning strategy used to produce the construct for deletion of *bpsI3147* is outlined in Figures 4.1 and 4.2. Primers were designed for performing splicing by overlapping extension PCR (SOE PCR), with engineered restriction sites (Chapter 2). Upstream and downstream flanking regions of *bpsI3147* were PCR-amplified from *B. pseudomallei* K96243 genomic DNA. PCR products were used as the template in a subsequent PCR to produce a spliced DNA fragment (mutagenesis cassette). The mutagenesis cassette was cloned into pJET1.2 and the insert confirmed by nucleotide sequencing (Chapter 2). To form the deletion construct, the mutagenesis cassette was subcloned into the lambda (  $\lambda$  ) *pir* dependent vector pDM4, which carries the negative-selectable *sacB* gene and a chloroamphenicol resistance cassette (Milton et al., 1996). The deletion construct was transformed into the Mu-free, auxotrophic *E. coli* MFD (Ferrières et al., 2010). Colonies containing the

correct deletion construct were confirmed after PCR and nucleotide sequencing of the insert DNA.

#### **4.3.1.2 Mutant production**

The mutagenesis strategy for making an unmarked *bps/3147* deletion mutant is outlined in Figure 4.2 (Logue et al., 2009). For mobilization of the pDM4 deletion construct into *B. pseudomallei* by conjugation, overnight cultures of *E. coli* and *B. pseudomallei* strains were spotted together on LB agar and grown overnight at 37°C. The first cross-over event resulted in the integration of the deletion construct into the host chromosome by homologous recombination. Integrants (merodiploids) were identified on LB agar containing chloroamphenicol (30 µg/ml) and confirmed by colony PCR.

A single integrant colony (merodiploid) was subcultured and plated on the counter-selective sucrose agar for selection of clones that underwent the second cross over event (Logue et al., 2009). Out of six chloroamphenicol-sensitive colonies screened using PCR analysis (Chapter 2 Section 2.5; Figure 4.3), one colony was confirmed as a mutant. Sequencing results confirmed a 1041 bp deletion in the *bps/3147* allele (Figure 4.4A). The mutant strain is named *B. pseudomallei* K96243 BPSL3147. Expression of *bps/3147* was only observed in the wild type and not in the K96243 BPSL3147 mutant (Figure 4.4C). Expression of adjacent genes *bps/3146* (Figure 4.4B) and *bps/3148* (Figure 4.4D) was observed in both the K96243 wild type and the BPSL3147 mutant.

Attempts to make a deletion mutant for the *vacJ* homologue (*bpss2331*) in chromosome 2 of *B. pseudomallei* were unsuccessful, despite screening over 85 colonies. The majority of the colonies remained chloroamphenicol-resistant merodiploids. Two clones which lost the chloroamphenicol resistance reverted to wild type.

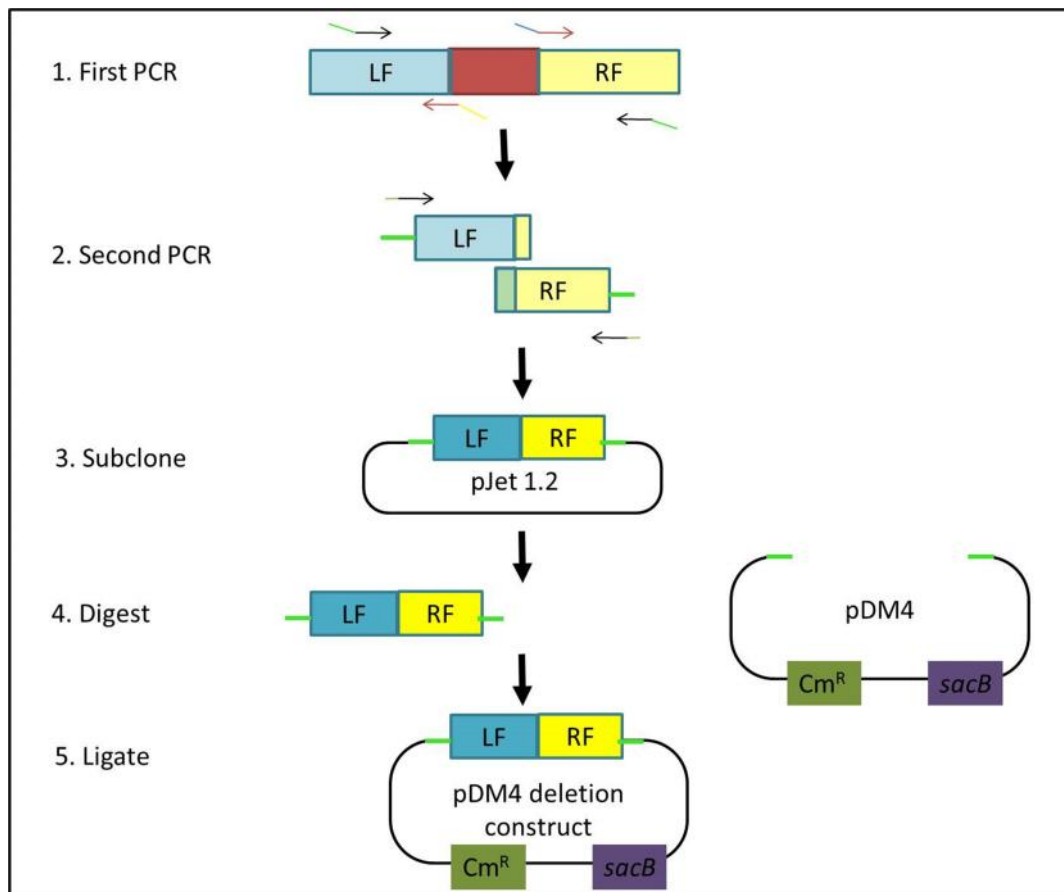

**Figure 4.1 Cloning strategy to produce the deletion construct.**

1. Flanking regions upstream (LF-left flank, shown in yellow) and downstream (RF-right flank, shown in blue) of the target gene (shown in red) were PCR amplified from genomic DNA using primers. The outer primers (black) contain specific restriction sites (green – *Xba*I). The inner primers (red) were designed to contain overlapping regions at the junction of the target flank.
2. A second PCR, using products from the first PCR, was performed using the outer primers with specific restriction sites.
3. The PCR product was cloned into a typical cloning vector pJet 1.2.
4. pDM4 and the insert were digested with specific restriction endonucleases.
5. The insert was ligated into restriction sites in pDM4.

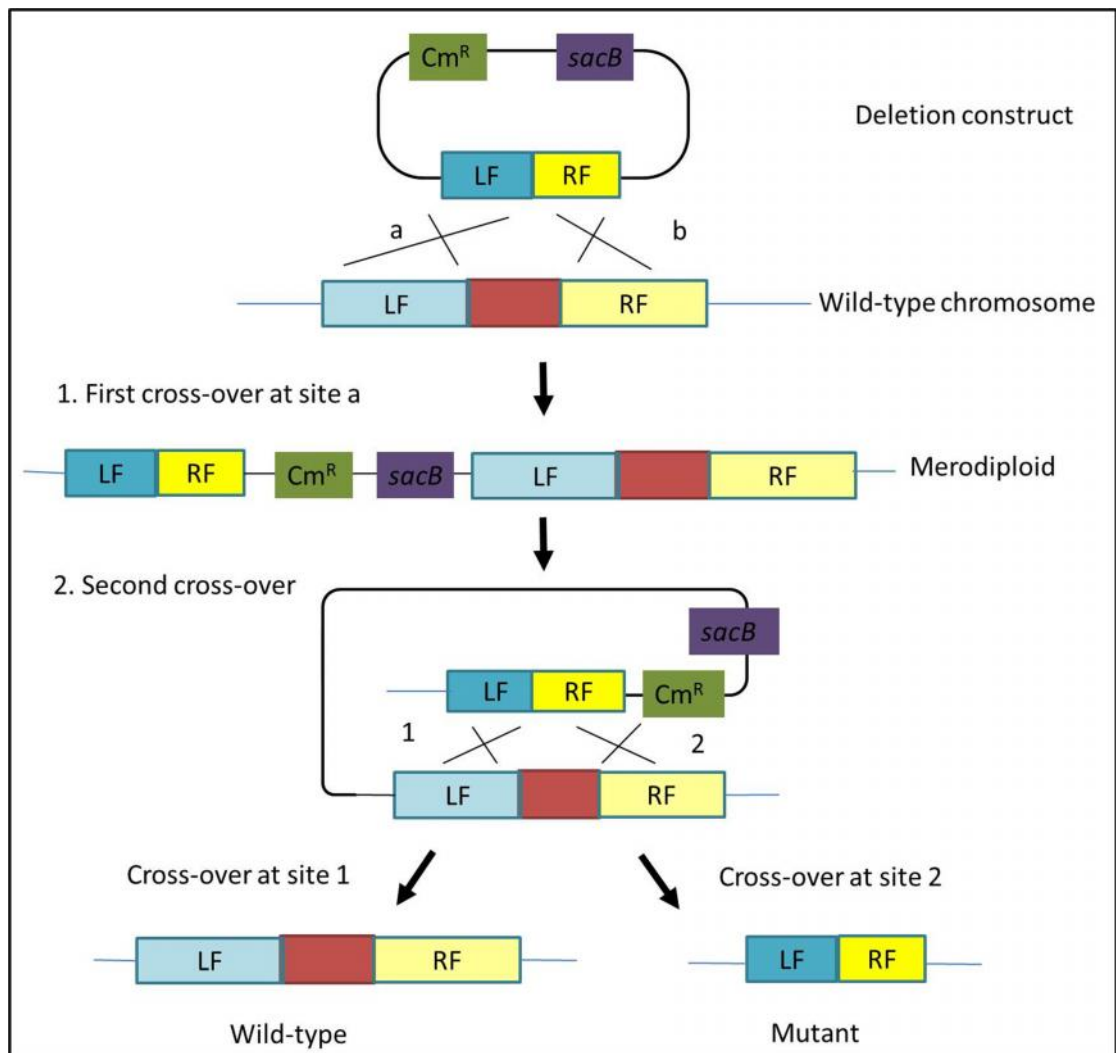

**Figure 4.2 Production of deletion mutant**

(Adapted from (Logue et al., 2009)).

1. During the first cross-over event, the deletion construct integrates into the genome by homologous recombination. The merodiploid integrant is resistant to chloroamphenicol (due to the presence of the chloroamphenicol resistance cassette,  $Cm^R$ ) but sensitive to sucrose (due to the presence of the  $sacB$  gene).
2. Sucrose is applied to select for bacteria that underwent a second cross-over event. The pDM4 backbone is excised from the genome, allelic exchange results in the generation of wild type revertant (cross-over at site 1) or the target mutant (cross-over at site 2). Strains are resistant to sucrose but sensitive to chloroamphenicol.



**Figure 4.3 Screening of *B. pseudomallei* deletion mutants**

Screening by PCR was performed using primers BTvacJL and BTvacJR3X (Chapter 2, Section 2.5). Following sucrose selection, Cm-sensitive colonies were screened for the presence of a smaller PCR product by using primers that flank the targeted deletion region. Legend: colony number 26, 28, 29, 30, 33, 34; pDM4  $\Delta$ vacJ<sub>Bp</sub>: PCR positive control; NTC: no template control. Colony 28 had a deletion in *bpsI3147* (PCR product 0.65 kb) and was designated *B. pseudomallei* BPSL3147. Other colonies were resolved as wild type *bpsI3147* (PCR product 1.6 kb).

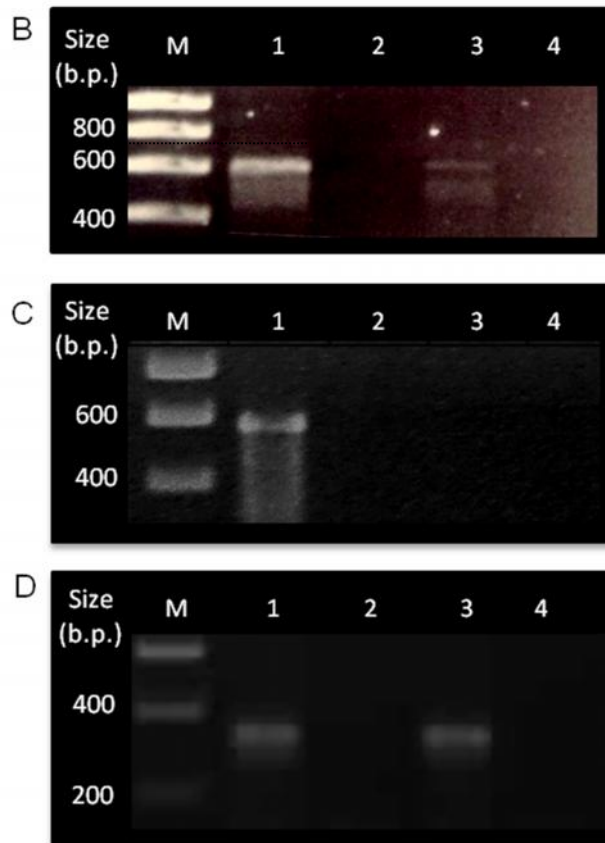
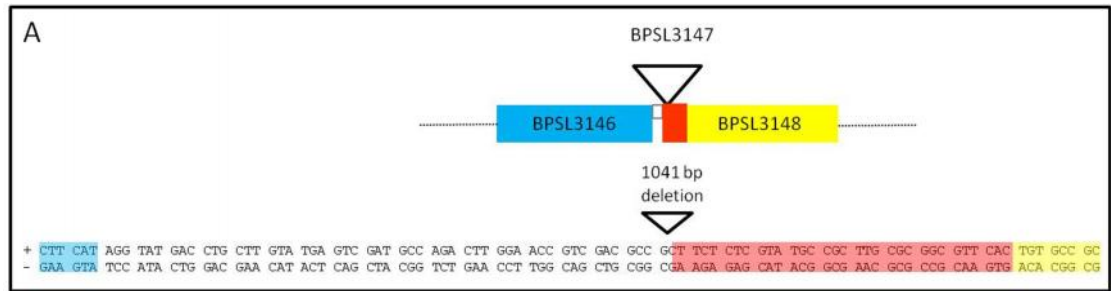

**Figure 4.4 Confirmation of BPSL3147 mutant by sequencing and reverse transcription PCR (RT-PCR) analysis.**

(A) Sequence of the *B. pseudomallei* K96243 BPSL3147 mutant. The region surrounding *bpsl3147* was sequenced using primers specific for the left and right flanks. The consensus sequence was aligned against the *B. pseudomallei* K96243 genome using standard nucleotide BLAST (NCBI). A 1041 bp deletion of *bpsl3147* was observed in the mutant.

(B)-(D) Reverse transcription PCR on RNA extracts from overnight cultures of *B. pseudomallei* K96243 wild type or K96243 BPSL3147 mutant using primers specific for (B) *bpsl3146*, (C) *bpsl3147* and (D) *bpsl3148*. Lanes 1 and 2: K96243 cDNA and RNA (no-RT control) respectively; lanes 3 and 4 BPSL3147 cDNA and RNA (no-RT control) respectively. Expression of *bpsl3146* (B) and *bpsl3148* (D) was observed in both the wild type and mutant. Expression of *bpsl3147* (C) was only observed in the wild type.

### 4.3.2 Growth in media

The growth rate of *B. pseudomallei* K96243 and the mutants used in this study (K96243 BPSL3147, 13H8, 13H8 BPSL3147) was determined in liquid media. Deletion of *bpsl3147* did not result in restricted growth in LB media (Figure 4.5).

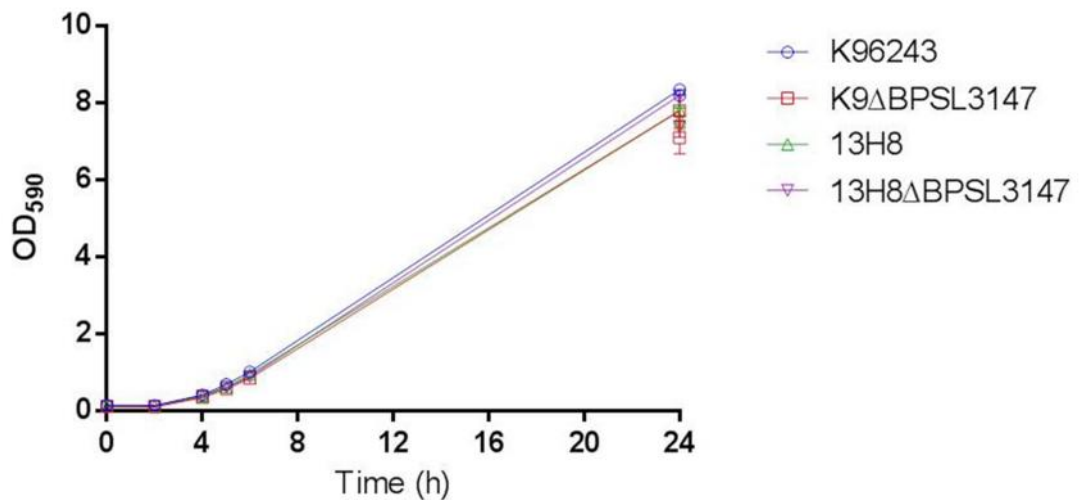

**Figure 4.5 Growth curve of *B. pseudomallei* wild type or VacJ mutants in LB broth at 37°C.**

Growth was monitored by absorbance at 590 nm over 24 h. Values are from a single experiment performed in duplicates.



#### 4.3.3 Virulence of *B. pseudomallei* BPSL3147 mutants *in vivo*

An acute, intranasal (i.n.) BALB/c mouse model of infection was chosen for the evaluation of virulence of the newly constructed *B. pseudomallei* K96243 BPSL3147 deletion mutant and the transposon insertion mutant 7A1 (with *bpsl3147* disrupted) identified from a previous study (Cuccui et al., 2007). The median lethal dose (MLD) of *B. pseudomallei* K96243 by the i.n. route in BALB/c mice was previously determined to be 10 CFU by Titball *et al.* (Titball et al., 2008). Groups of six mice were infected via the i.n. route with *B. pseudomallei* K96243 (413 colony forming units (CFU)); *B. pseudomallei* 7A1 (450 CFU) or *B. pseudomallei* BPSL3147 (467 CFU). All mice challenged with the wild type *B. pseudomallei* were moribund and euthanized by day 4 (Figure 4.6). In contrast, all mice challenged with the *B. pseudomallei* K96243 VacJ mutants survived over the observed period for 45 days ( $p < 0.01$ ) (Figure 4.6).

The organ load kinetics of BALB/c mice infected with the *B. pseudomallei* K96243 strains was investigated by analysing the viable CFU present in the lungs and spleens of infected animals (Figure 4.7). Groups of five BALB/c mice were challenged (i.n.) with *B. pseudomallei* K96243 (530 CFU) or *B. pseudomallei* K96243 BPSL3147 (535 CFU). At 24 h post challenge, comparable bacterial loads (about  $10^5$  CFU /organ) were observed in the lungs of both groups, indicating a rapid increase in bacterial replication in the lungs (Figure 4.7A). However, by 48 h, the bacterial counts in the lungs of mice challenged with the *B. pseudomallei* K96243 BPSL3147 mutant dropped to a lower level (about  $10^4$  CFU / organ) while in wild type infected mice, bacterial counts were considerably higher (about  $10^7$  CFU / organ)

(Figure 4.7A). At 24 h post challenge, the bacterial counts in the spleens were below the detection limit (500 CFU/organ, data not shown). At 48 h post challenge, the bacterial counts in the spleens of wild type-infected mice increased to more than  $10^5$  CFU / organ, while the bacterial counts in the spleens of mice infected with the mutant remained low (about  $10^2$  CFU / organ) (Figure 4.7b). At 48 h post challenge, some bacteria ( $10^4$  CFU /ml) were recovered from whole blood of wild type-infected mice (detection limit  $10^2$  CFU/ml blood) (Figure 4.7C).

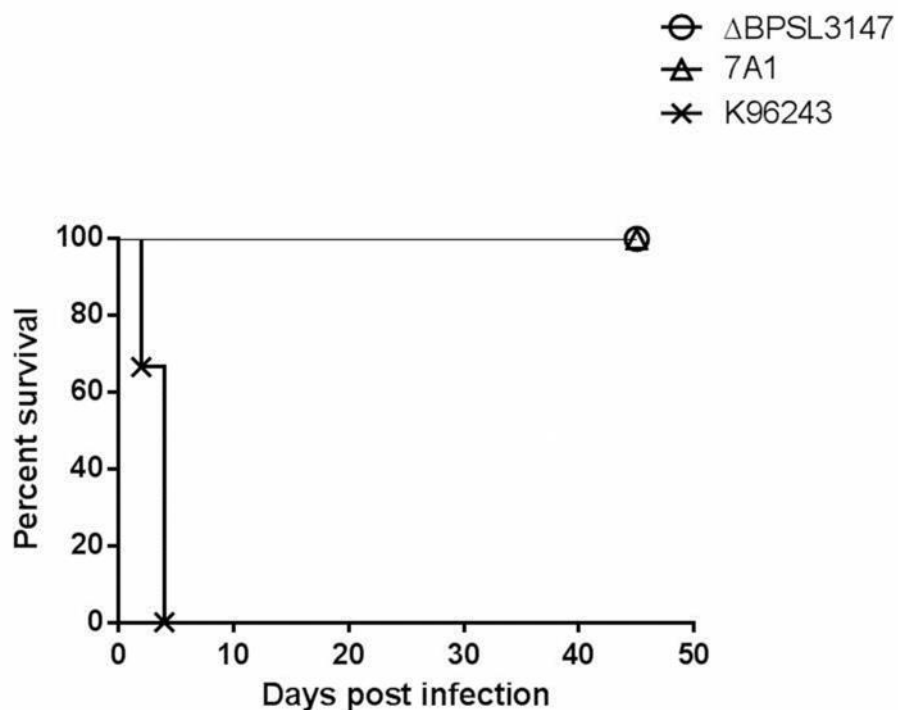

**Figure 4.6 Survival data of i.n. infection of BALB/c mice.**

Groups of six female mice were infected with *B. pseudomallei* K96243 (x, 413 CFU) or defined VacJ mutants 7A1 ( , 450 CFU) or K96243 BPSL3147 ( , 467 CFU) and monitored for survival. Median survival time of mice infected with *B. pseudomallei* K96243 was 4 days.

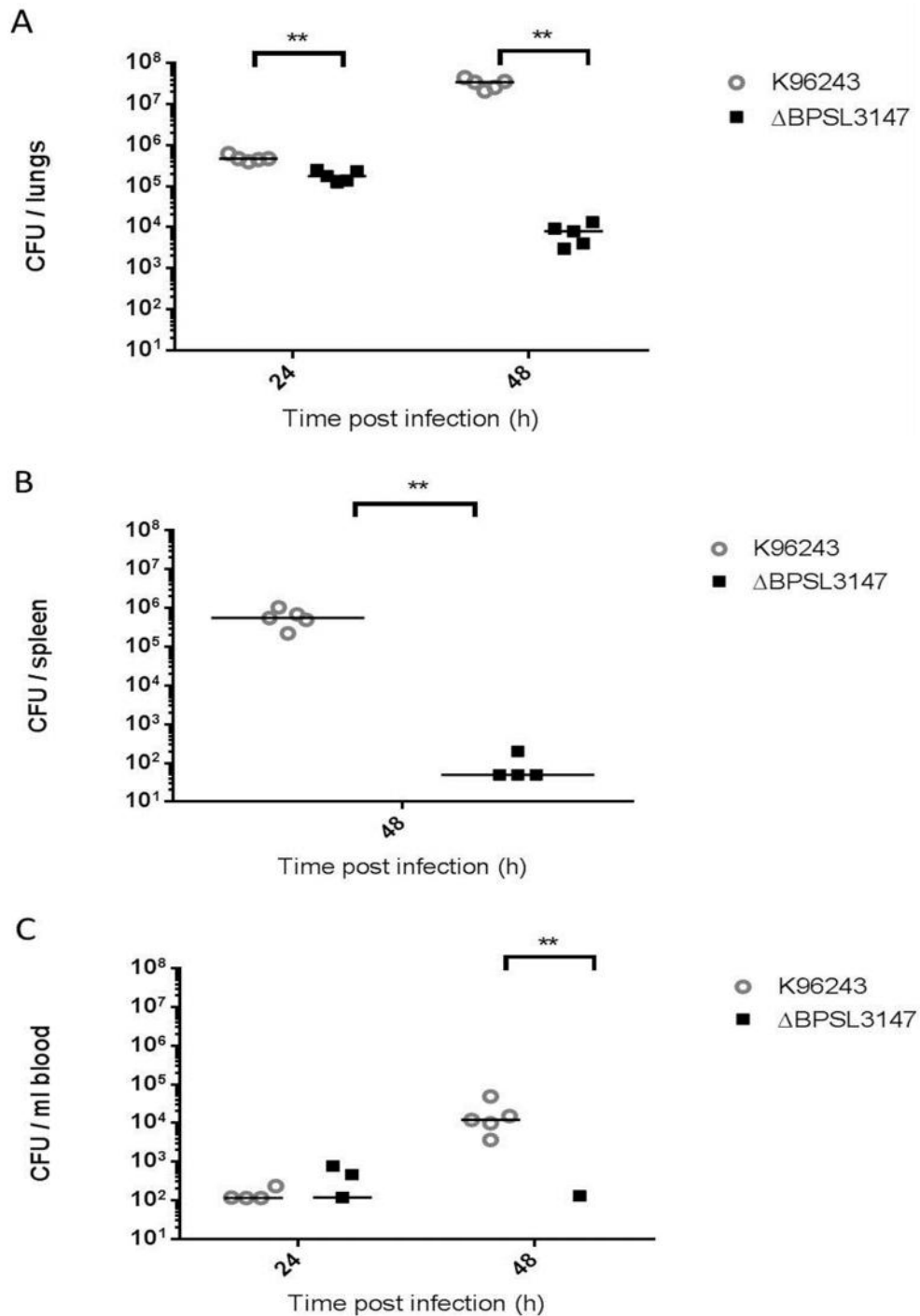

**Figure 4.7 Differential susceptibility to colonization by *B. pseudomallei* mutant BPSL3147 in BALB/C mice.**

BALB/c mice ( $n = 5$ ) were infected (i.n.) with 500 colony-forming units (CFU) *B. pseudomallei* wild type strain K96243 or mutant BPSL3147. The lungs (A), spleen (B) and heparinized blood (C) were harvested on days 1 and 2 post challenge. A, B, C: Bacterial loads from lungs, spleen and blood, respectively. The horizontal bar indicates the median value. Statistical significance was determined using the Mann-Whitney test; \*\*  $p < 0.01$ .

#### **4.3.4 Infection of mammalian cell lines**

*B. pseudomallei* can survive and replicate in a range of cell lines (Jones et al., 1996, Harley et al., 1998). To determine if VacJ is required for intracellular growth and survival, I compared the *B. pseudomallei* BPSL3147 mutant to the wild type strain for their abilities to invade, replicate and spread within cultured cell monolayers.

##### **4.3.4.1 Infection of A549 epithelial cells**

A549 human lung epithelial cells were infected with *B. pseudomallei* K96243 wild type or BPSL3147 at MOI of 5. At 2 and 4 h post infection, infected cells were lysed and the number of viable bacteria within the cells was determined (Figure 4.8). No significant difference between the wild type and the BPSL3147 mutant for adherence of A549 epithelial cells was observed.

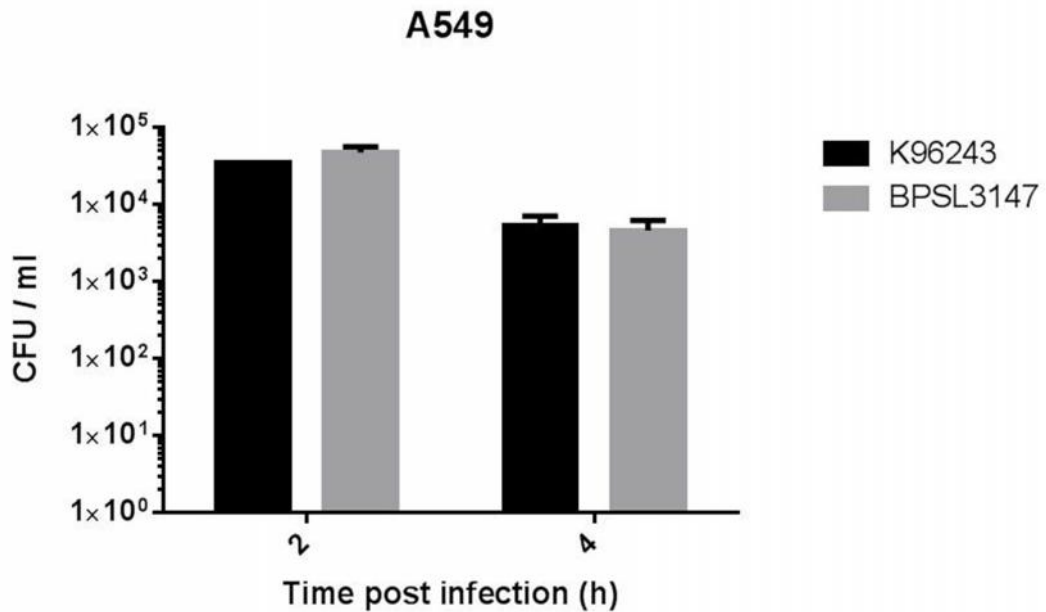

**Figure 4.8 Adherence or invasion of A549 epithelial cells by *B. pseudomallei* K96243 wild type or BPSL3147 strains.**

The mean bacterial recoveries (CFU/ml) ± standard error of mean (SEM) at 2 h (adhesion) and 4 h (invasion) post infection (MOI 5) are shown. Data is representative of 2 experiments, performed in duplicates. No significant differences were observed between the strains.

#### **4.3.4.2 Growth and survival within J774A.1 murine macrophages**

J774A.1 murine macrophages were infected with *B. pseudomallei* K96243 wild type or BPSL3147 strains at MOI of 1. At 2, 4, 6 and 24 h post infection, infected cells were lysed and the number of viable bacteria within the cells was determined (Figure 4.9). At the time points tested, there were no significant differences between the wild type and mutant for intracellular survival in J774A.1. Following an initial decline in numbers after internalization, both the wild type and mutant strains were able to replicate within the macrophage at similar levels, as seen by the increase in intracellular CFUs at 24 h post infection.

*B. pseudomallei* has previously been shown to form multinucleated giant cells (MNGCs) upon invasion of macrophages (Kespichayawattana et al., 2000). As previous studies reported that the *S. flexneri* VacJ mutant showed impairment in the ability to infect neighbouring cells by intercellular spreading (Suzuki 1994, Carpenter 2013), I sought to determine if VacJ played a similar role in *B. pseudomallei*. No significant contribution of VacJ to multinucleated giant cell formation was observed (Figure 4.10).

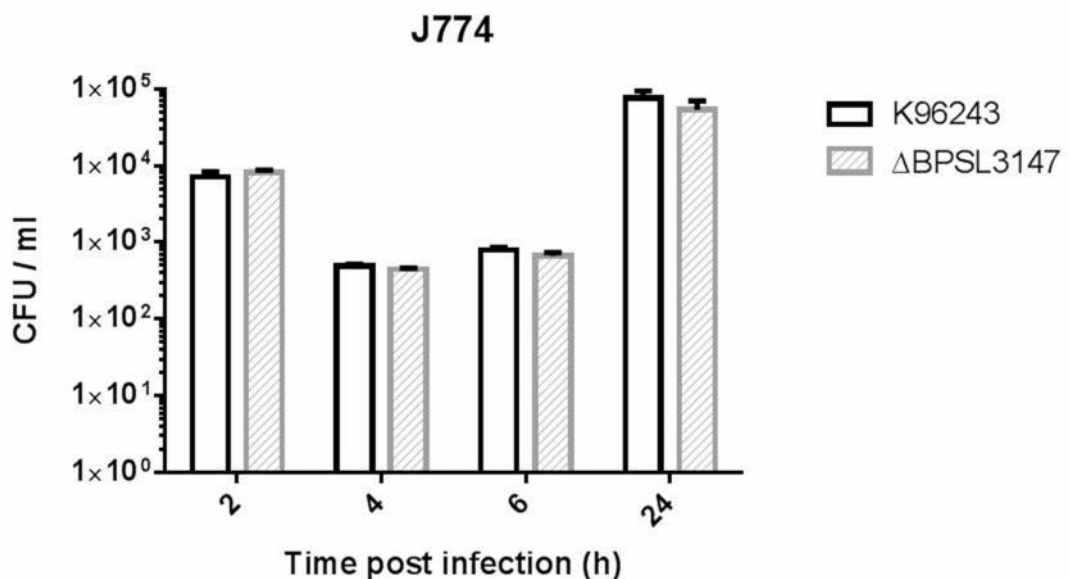

**Figure 4.9 Intracellular replication of *B. pseudomallei* K96243 or BPSL3147 mutant strain in J774A.1 murine macrophage-like cells.**

The mean bacterial recoveries (CFU/ml  $\pm$  SEM) with triplicate measurements are shown. Bacteria were recovered from lysed J774A.1 cells at 2, 4, 6 and 24 h post infection (MOI 1) and enumerated by serial dilution onto LB agar. No significant differences were observed between the strains. Data is representative of two experiments performed in triplicates.

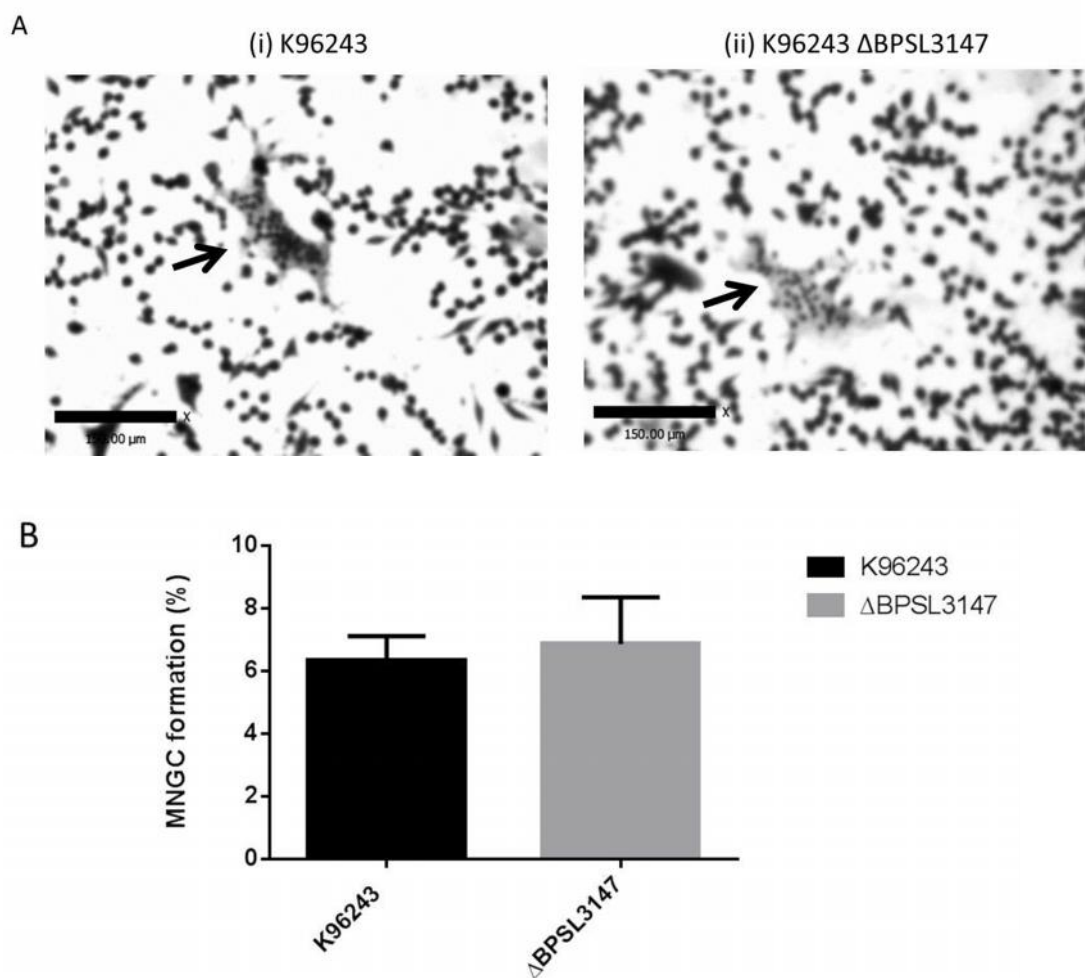

**Figure 4.10 Multinucleated giant cell formation was observed in Giemsa-stained J774A.1 cells infected with (i) *B. pseudomallei* wild type or (ii) BPSL3147 mutant strain.**

(A) The cells were infected at an MOI of 1 for 18 h, stained with Giemsa and viewed using bright field microscopy. Scale bar = 150  $\mu$ m. Arrows indicate the multinucleated giant cell formation. Data is representative of two experiments.

(B) The percentage of MNGC formation ( $\pm$  SEM) was calculated relative to normal macrophages. MNGCs were defined as cells containing 3 or more nuclei (% MNGC formation = Number of nuclei in MNGC / Number of normal macrophages  $\times$  100). The error bars represent the standard error of the mean derived from 8 fields of view. No significant differences were observed between the mean number of MNGCs in cells infected with the *B. pseudomallei* wild type or the mutant strain.

#### 4.3.5 Serum Survival

Since the *in vivo* attenuated phenotype of the *B. pseudomallei* VacJ mutant could not be attributed to an intracellular growth defect, I next investigated the survival of VacJ mutants in normal human serum (NHS). *B. pseudomallei* was previously shown to display resistance to the killing effects of human serum by virtue of the presence of LPS and the capsule (DeShazer et al., 1998, Reckseidler-Zenteno et al., 2005, Woodman et al., 2012). The LPS is absolutely required for complete resistance to serum. While the capsule is not essential for *B. pseudomallei* to resist direct killing by human serum, the presence of a capsule can improve the survival of a serum sensitive strain by reducing the deposition of complement protein C3 deposition on the bacterial cell surface (Reckseidler-Zenteno et al., 2005).

*B. pseudomallei* wild type and mutant strains were incubated in 30 % NHS for 2 h and then enumerated by plate counting. No viable *E. coli* were detected after 2 h incubation in 30 % NHS, demonstrating the killing activity of NHS. Direct killing of *E. coli* was not observed in heat-inactivated serum (Hi-NHS), indicating the mechanism is mediated by heat labile components in serum (complement) (Figure 4.11). In agreement with previous reports (Ismail et al., 1988, DeShazer et al., 1998, Reckseidler-Zenteno et al., 2005, Woodman et al., 2012, Egan and Gordon, 1996), the viability of the *B. pseudomallei* K96243 wild type and the capsular mutant 13H8 were unaffected by the addition of NHS, confirming these strains are resistant to serum bactericidal activity (Figure 4.11).



Initial experiments revealed that the *B. pseudomallei* BPSL3147 mutant displayed similar viability with the wild type strain in NHS. Since the presence of a capsule may contribute to serum resistance, I further explored this phenotype by constructing an acapsular BPSL3147 mutant (13H8 BPSL3147) using a previously characterized *B. pseudomallei* K96243 mutant 13H8 (Tn5::*wcbB*) (Cuccui et al., 2007) as the parent strain using similar methods outlined in section 4.3.1.2, and investigated the survival of the mutant in NHS.

The acapsular BPSL3147 mutant (13H8 BPSL3147) displayed significant susceptibility to the serum bactericidal activity and was unaffected by Hi-NHS (Figure 4.11).

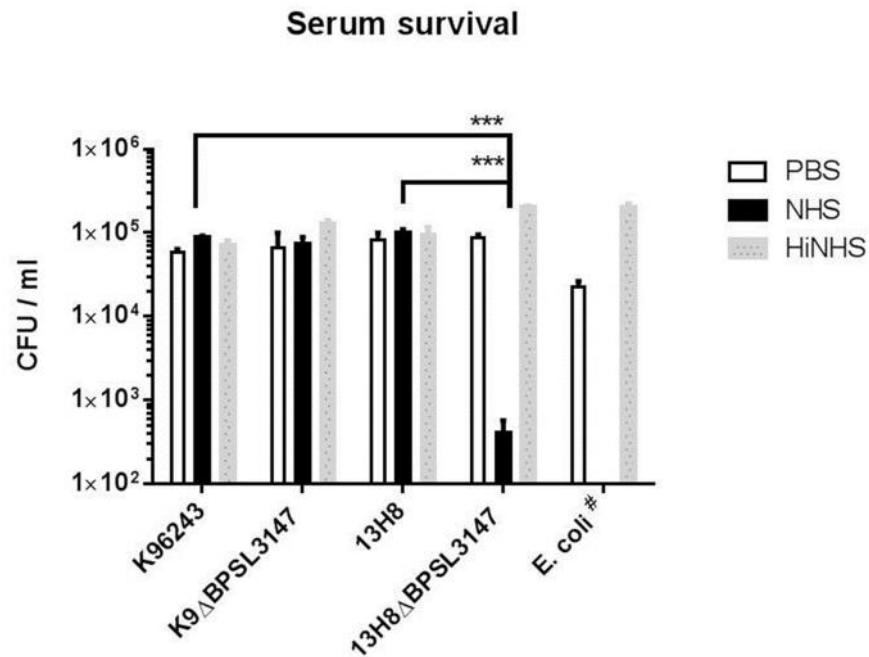
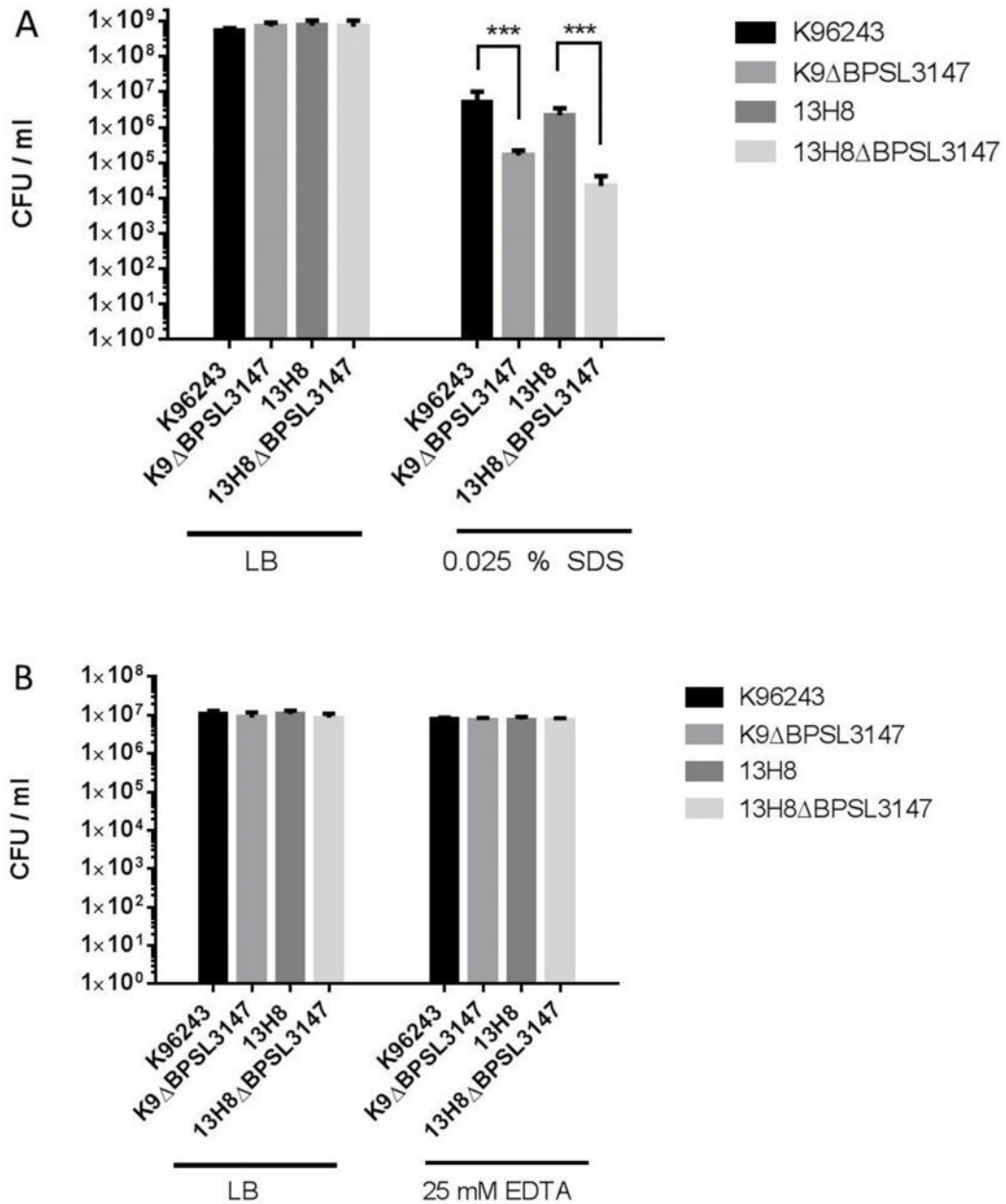

**Figure 4.11 Serum survival assay on *B. pseudomallei*.**

Bacterial strains were incubated for 2 h at 37 °C with PBS, 30% pooled complement human serum (30% NHS, Patricell, UK) or heat inactivated NHS (Hi-NHS). Bacterial colony forming units (CFU/ml) were enumerated by serial dilution and plating onto LB agar. The bars represent the means  $\pm$  standard deviation, representative of two independent experiments (\*\*\*)  $p < 0.001$  by unpaired *t*-test comparing means of bacterial counts). # No *E. coli* colonies were recovered after incubation with 30 % NHS.

#### 4.3.6 Growth inhibition assays

I next examined the role of VacJ in outer membrane stability. The *B. pseudomallei* BPSL3147 mutants were tested for survival in the presence of either EDTA, a chelator of divalent cations which compromises the outer leaflet by interrupting intermolecular associations between LPS phosphate groups, or the anionic surfactant sodium dodecyl sulphate (SDS). Both the wild type and mutant strains displayed similar sensitivity to EDTA, but the *B. pseudomallei* BPSL3147 mutants showed an increased sensitivity to SDS (Figure 4.12), implying a defect in the barrier function.

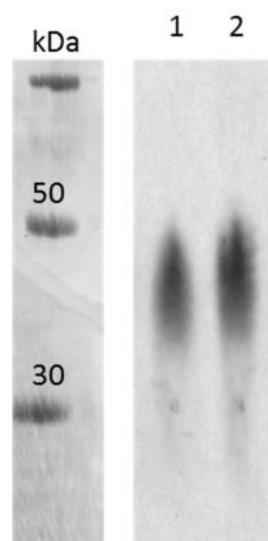

**Figure 4.12 Membrane stability of *B. pseudomallei* K96243 and mutant strains.**

Following overnight culture, bacterial dilutions were plated on LB agar in the presence or absence of (A) 0.025 % SDS or (B) 25 mM EDTA. Viable counts were obtained after incubation at 37 °C for 24 – 48 h. Values represent means ± standard deviation of two independent experiments performed in triplicate (\*\*\*)  $p < 0.001$  by one-way ANOVA and Bonferroni's posthoc test).

#### 4.3.7 Detection of LPS in *B. pseudomallei* BPSL3147

Bacterial cultures were grown to log phase in LB and collected by centrifugation. Cells were heat-killed and loaded on a 10 % Bis-Tris gel for SDS-PAGE. Separated proteins were transferred onto a nitrocellulose membrane and detected using an anti-LPS monoclonal antibody (MAb) CC6 (Jones et al., 2002). The *B. pseudomallei* BPSL3147 mutant appeared to express LPS at similar levels with the wild type (Figure 4.13).

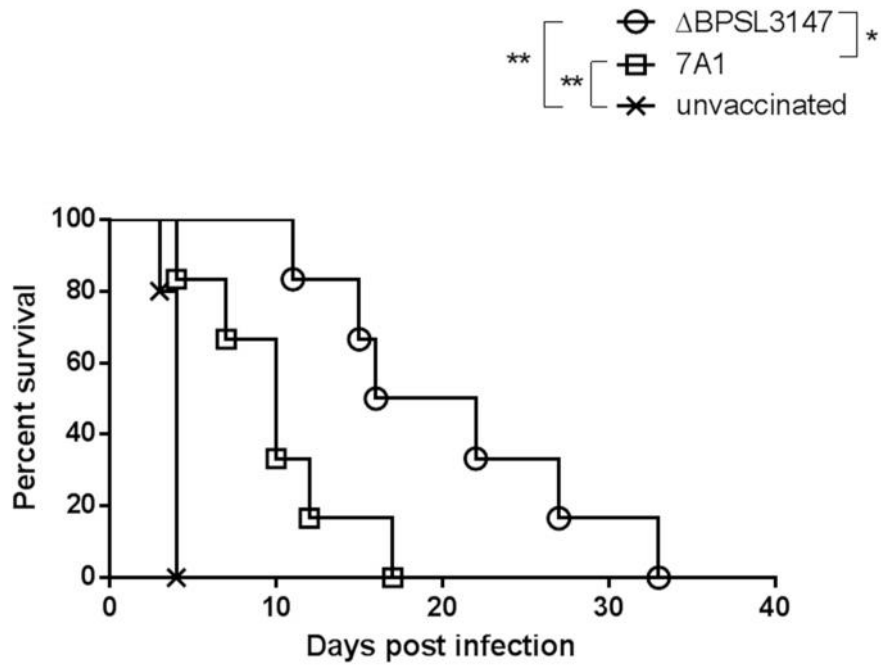

**Figure 4.13 Western blot staining LPS from *B. pseudomallei* strains.**

0.2 OD of heat-killed log phase bacterial culture was loaded on a 10 % Bis-Tris gel (MOPS buffer). The proteins were transferred onto a nitrocellulose membrane and detected using an anti-LPS monoclonal antibody CC6 (Jones, 2002). The kDa ladder shows the size of marker proteins. Lane 1: K96243; lane 2: K96243 BPSL3147.

#### **4.3.8 Protective effects by infection with *B. pseudomallei* BPSL3147 in BALB/c mice**

The protective efficacy of the *B. pseudomallei* BPSL3147 mutants was determined using a BALB/c mouse infection model. Groups of six mice were dosed i.n. with 500 CFU of *B. pseudomallei* K96243 VacJ mutants (7A1 or BPSL3147). After 7 weeks, these mice were challenged with 500 CFU of wild type *B. pseudomallei* K96243 (approximately 50 MLD). Six unvaccinated mice were included as the naïve control group. The median survival time increased from 4 days in unvaccinated mice to 10 days in mice vaccinated with 7A1 and 19 days in mice vaccinated with BPSL3147 (Figure 4.14) ( $p < 0.01$  for both mutants), indicating a protective effect by the VacJ mutant.



**Figure 4.14 Protection assay of BALB/c mice vaccinated with *B. pseudomallei* VacJ mutants.**

Groups of six mice were vaccinated with *B. pseudomallei* BPSL3147 ( , 467 CFU) or *B. pseudomallei* 7A1 ( , 450 CFU). At day 45 post vaccination, the mice were challenged with 500 CFU of wild type *B. pseudomallei* K96243. Age-matched unvaccinated mice (x) were included in this study. Median survival time of the unvaccinated mice, and mice vaccinated with the BPSL3147 or 7A1 mutant strains were 4 days, 19 days and 10 days respectively. Statistical significance was determined using the log-rank Mantel-Cox test; \*\*  $p < 0.01$ , \*  $p < 0.05$ .

#### 4.4 Discussion

To study and define a given bacterial gene of interest, interruption of the gene or mutagenesis is typically performed. Typical mutagenesis strategies include insertional mutation with a selectable cassette (e.g. antibiotic cassette), or allelic exchange with a modified allele. Insertional mutation can cause polar effects when frameshift, nonsense or antisense disruption of an open reading frame (ORF) within an operon affects upstream or downstream gene expression, or when there is RNA instability (Reyrat et al., 1998). This could cause confusion in the assignment of the mutant phenotype. To minimize the polar effects, in-frame deletions using allelic exchange mutagenesis was demonstrated (Link et al., 1997, Logue et al., 2009). The double selection strategy for allelic mutagenesis is useful for the construction of defined unmarked mutants with changes that are usually undetectable, such as point mutations or in-frame deletions. In the first step, a vector harbouring the modified allele is integrated into the genome due to a single crossover, and the clones selected owing to a selectable antibiotic resistance gene (merodiploids). In the second step, clones that lose the vector due to a second crossover are selected by plating on a counterselective medium (Reyrat et al., 1998). Mutants are screened for the loss of the selectable antibiotic resistance encoded by the vector and confirmed by PCR analysis.

The *Bacillus subtilis sacB* gene encoding a levansucrase, which catalyses sucrose hydrolysis and levan extension, is a popular counter-selectable marker, particularly for the mutagenesis of Gram-negative bacteria. Cloning of *sacB* in *E. coli* and other Gram-negative bacteria leads to the death of the transformed bacteria when they are plated in the presence of sucrose, owing

to undefined mechanisms (Gay et al., 1983). Recently, Logue *et al.* (2009) has demonstrated the use of *sacB* as a counterselectable marker for generating in-frame deletions in *B. pseudomallei* (Logue et al., 2009). *B. pseudomallei* K96243 is naturally sensitive to sucrose, possibly due to endogenous expression of *sacB*, and this may circumvent the generation of sucrose-resistant clones from a merodiploids. However, appropriate conditions, such as plating at low cell density and extended incubation (> 72 h), aid the excision of the vector with the counterselectable marker (Eberl, 2006). This method has been chosen to generate unmarked, non-polar deletion mutants in *B. pseudomallei* and *B. thailandensis*.

In this study, I investigated the role of the gene *bpsl3147* in *B. pseudomallei* pathogenesis by constructing unmarked, non-polar mutants with in-frame deletions. The gene *bpsl3147* encodes a lipoprotein that was identified as important for *in vivo* virulence and spleen tropism in the acute intranasal BALB/c mouse infection model (Cuccui et al., 2007). The lipoprotein BPSL3147 shared significant amino acid similarity to VacJ orthologues in *S. flexneri*, *E. coli* (MlaA) and *H. influenzae*. Besides contributing to maintenance of outer membrane stability in these bacteria (Carpenter et al., 2014, Malinverni and Silhavy, 2009, Nakamura et al., 2011), VacJ is a virulence factor that contributes to the intercellular spread of *S. flexneri* (Suzuki et al., 1994) and serum resistance in non-typeable *H. influenzae* (Nakamura et al., 2011). *B. pseudomallei* encodes another VacJ homologue (BPSS2331) on chromosome 2, which may provide redundancy in function to BPSL3147. Unfortunately I was unable to construct a defined mutant for this gene at this time.



The work described here confirmed that the BPSL3147 VacJ lipoprotein affect *B. pseudomallei* virulence dramatically, as evidenced by the total attenuation of the *B. pseudomallei* VacJ mutants in infected BALB/c mice. Several possible mechanisms could account for the attenuation of the *B. pseudomallei* VacJ mutant in the i.n. infection model. These include (i) reduced colonization of tissues, (ii) reduced dissemination from the primary site of infection (lung) or (iii) reduced tissue damage at key sites of infection. One of the key findings in this study is that the *B. pseudomallei* VacJ mutant was able to replicate rapidly and colonize the lungs during the initial phases of infection (24 h post infection [p.i.]), but was unable to sustain the infection in lungs by 48 h, resulting in reduced bacterial counts in the lung. In contrast, the numbers of wild type bacteria present in the lungs increased over the course of the experiment. Very few bacterial colony forming units of the mutant strain were detected in the blood or spleens of infected animals, while the levels of wild type *B. pseudomallei* became detectable in blood and spleen by 48 h p.i. These results imply that VacJ is not critical for initial colonization of the primary site of infection (lungs), but may be important for sustaining the infection, overcoming host immune cascade responses and/or dissemination to distal sites of infection (blood, spleen). In future work it would be interesting to evaluate the host immune response and extent of tissue damage at key sites of infection.

I next attempted to investigate the specific role of VacJ during intracellular infections by examining mutants of *B. pseudomallei* in a tissue culture model. As previous studies reported that the *S. flexneri* VacJ mutant showed impairment in the ability to infect neighbouring cells by intercellular spreading

(Suzuki et al., 1994, Carpenter et al., 2014), I sought to determine if VacJ plays a similar role in *B. pseudomallei*. I found no obvious defect in the VacJ mutants for any of the major components of the *Burkholderia* intracellular life style, including adherence and invasion into A549 lung epithelial cells and internalization into J774A.1 murine macrophages and intracellular replication. Moreover, I found no significant contribution of VacJ to multinucleated giant cell formation, which is dependent on cell-to-cell spread. It is thus likely that VacJ does not play a critical role in intercellular spreading of *B. pseudomallei* during initial phases of *in vitro* infection. A previous study by Wikraiphat et al. (Wikraiphat et al., 2009) demonstrated that the presence of the capsule correlated with enhanced resistance against intracellular killing of *B. pseudomallei* such as by antimicrobial peptides and reactive oxygen intermediates (ROI) in RAW 264.7 mouse macrophage cell line. Thus, the presence of a capsule may enhance resistance against intracellular killing and mask any pleiotropic defects in the *B. pseudomallei* VacJ mutant in the time points tested.

As I was unable to ascribe the *in vivo* attenuation of the *B. pseudomallei* VacJ mutants to a defect in intracellular replication or survival, I next sought to investigate other factors that may affect bacterial fitness during mammalian infection, such as sensitivity to bactericidal activity of human sera. While the *B. pseudomallei* VacJ mutant was insensitive to killing by human sera, I found that a double mutant lacking both VacJ and a functional polysaccharide capsule displayed sensitivity to human serum. One likely explanation for this phenotype is that the presence of a capsule contributes to survival in serum by reducing deposition of the complement factor C3b on

the bacterial surface (Reckseidler-Zenteno et al., 2005) and may inhibit the effectiveness of the complement cascade on the *B. pseudomallei* VacJ mutant. Previous studies reported the addition of purified capsule increased the survival of a serum-sensitive *B. pseudomallei* mutant (Reckseidler-Zenteno et al., 2005). The complement system plays an integral role in host innate immune system in killing pathogenic microorganisms (Taylor, 1983, Rooijackers and van Strijp, 2007). Activation of the various complement pathways (classical, lectin and the alternative pathways) are triggered by various proteins that recognise bacterial ligands, and lead to deposition of opsonins and/or assembly of pore-forming membrane attack complex (MAC) on microbial surfaces and bacterial elimination. In order to establish an infection, many pathogens utilize multiple evasion strategies to control host complement response and evade opsonophagocytic killing or direct lysis. These strategies include having the barrier function of the outer membrane components (Taylor, 1983), binding of complement regulatory proteins, binding or production of complement inhibitors, and production of proteases with specificity for complement factors (Blom et al., 2009). Consequently, these strategies prevents the deposition of complement to critical levels on the cell surface or influence deposition to non-critical sites such as the polysaccharide, without affecting the outer membrane (Frank et al., 1987). *B. pseudomallei* has been shown to be a potent activator of complement, but is able to subvert the complement cascade at later time points of infection, including preventing the MAC from depositing at a microbicidal location on the bacterial surface (Ismail et al., 1988, Egan and Gordon, 1996, Feingold et al., 1968). The O-polysaccharide (O-PS) moiety of the *B. pseudomallei*

LPS is essential for serum resistance, but the mechanism for resistance to direct killing by complement is not fully understood (DeShazer et al., 1998, Woodman et al., 2012). Since the *bpsl3147* mutation did not affect the LPS, it is likely that the VacJ is an additional factor that affects serum resistance, possibly by affecting the outer surface. Although the serum sensitivity was only observed in the acapsular 13H8 BPSL3147 mutant, complementation would be required to confirm this phenotype. Given the restrictions on the introduction of selectable antibiotic cassettes in *B. pseudomallei*, the choice of selectable antibiotic resistance markers that can be used in vectors for complementing the kanamycin-resistant 13H8 BPSL3147 mutant becomes limited. It may be useful to knockout the capsular genes in the K96243 BPSL3147 mutant using unmarked deletion methods as described above for further studies.

Compared to wild type, the VacJ mutants have similar sensitivity to EDTA, but appeared to be more sensitive to the bacteriolytic effect of SDS, indicating a possible defect in the outer membrane. Typically, EDTA disrupts the LPS and consequently leads to perturbations of outer membrane structure and function, and can lead to cell death; while detergents (e.g. SDS) solubilize cell membrane proteins and lipids and lyse cells. Orthologues of VacJ have been attributed with a similar function in maintenance of outer membrane stability, particularly in maintaining the stability of the outer leaflet by recycling phospholipids from the outer leaflet to the inner leaflet and determining key characteristics of cell surface (Malinverni and Silhavy, 2009). VacJ is also attributed to tight packing of the phospholipid surface layer of *H. influenzae*, thereby limiting access to oligosaccharide epitopes recognized by

bactericidal antibodies (Nakamura et al., 2011). Disruption in the outer membrane may cause pleiotropic effects on presentation of cell surface antigens, and lead to the differential host immune responses which may affect bacterial viability. I postulate that mutation of VacJ altered cell surface characteristics, allowing the MAC to gain access to microbicidal locations on the bacterial surface. The instability of the outer membrane could also lead to reduced resistance to other host defence systems such as opsonophagocytosis (initiated through the binding of opsonins to the bacterial membrane), antimicrobial peptides (binding to target bacterial membrane) or intracellular oxidative stress (where free radicals may attack DNA, RNA, proteins, and polyunsaturated fatty acids in lipids, leading to complex chain reactions that affect viability). Lipid peroxidation may result in decrease in membrane fluidity and altered membrane properties, as well as the degradation of the polyunsaturated fatty acids to aldehydes that can damage protein molecules (reviewed in (Cabiscol et al., 2000)).

With the increasing incidence of *B. pseudomallei* infections (Limmathurotsakul et al., 2010a, Currie et al., 2008, Currie et al., 2010) and its classification as a Tier 1 biological agent by the CDC, there is an urgent need for a protective vaccine against this organism. The intracellular nature of *B. pseudomallei* confers major challenges in vaccine development as elimination of the pathogen would be highly reliant on the cell-mediated immune responses (Choh et al., 2013). Live attenuated vaccines have been used to prevent a number of infectious diseases such as polio and tuberculosis. They are advantageous over subunit vaccines because of the wider repertoire of antigens presented to the host, and can stimulate both the

antibody-mediated and cellular arms of immune responses (Atkins et al., 2002b, Silva and Dow, 2013). The *in vivo* phenotypes observed for the *B. pseudomallei* VacJ mutant suggest that it has potential as a live vaccine candidate. I found that vaccination with the *B. pseudomallei* VacJ mutant resulted in a significantly increased time to death in mice that were subsequently challenged i.n. with 50-fold minimal lethal dose of *B. pseudomallei* K96243 compared to unvaccinated mice. However, all vaccinated mice did not acquire sterilizing immunity, eventually succumbed to infection, and died. To date, some of the investigated *B. pseudomallei* live attenuated vaccines such as auxotrophic mutants and the T3SS mutants have demonstrated significant but incomplete protection from acute challenge with *Burkholderia* (reviewed in (Silva and Dow, 2013, Choh et al., 2013)). Of interest, a capsular mutant did not provide protection against virulent challenge (Atkins et al., 2002a). Given that the *B. pseudomallei* VacJ mutant displayed attenuation of virulence in mice and significant level of protection against an acute intranasal virulence challenge, there is considerable scope to optimize this vaccine, and perhaps use it in combination with conventional antibiotic therapy to promote bacterial clearance.

To date, development of live attenuated vaccines for *B. pseudomallei* involves knockout of a single gene, and there may be major concerns regarding the reversion of an attenuated strain to wild type strain in the environment. One alternative approach is to exploit two or more independent site-specific knockouts using genetic techniques used in this study, but caution should be taken to ensure there is no over attenuation that may lead

to reduced immunogenicity (Choh et al., 2013). Ultimately, understanding the specific mechanisms behind *Burkholderia* pathogenesis and host-pathogen interactions will provide a stronger platform for the development of potential vaccines and antimicrobial agents.

## 5. Chapter 5 Characterization of VacJ in *Burkholderia thailandensis*

### 5.1 Introduction

The VacJ lipoprotein (BPSL3147) is an outer membrane protein that is required for causing *in vivo* virulence in *B. pseudomallei* (Cuccui et al., 2007) (Chapter 4). VacJ was first identified in *S. flexneri* to be a lipoprotein required for intercellular spread. It was also found to be required for the maintenance of outer membrane asymmetry (Mla) in *E. coli* and in non-typeable *H. influenzae* VacJ contributes to serum resistance. In Chapter 3, BTH\_I3001 was identified as a VacJ orthologue in *B. thailandensis* highly similar to BPSL3147 (92 % amino acid identity). Similar to *B. pseudomallei*, the organization of the *mia* locus surrounding *bth\_i3001* is preserved (Figure 3.2). Similar to *B. pseudomallei*, a second VacJ homologue, BTH\_II2351, with 47 % amino acid identity to BPSL3147, was identified in *B. thailandensis*. The genes surrounding *bth\_ii2351* did not display similarity to the genes from the *mia* pathway.

Although *B. thailandensis* is considered relatively nonpathogenic in humans, it exhibits similar intracellular life cycles with *B. pseudomallei* and can cause fulminant, lethal infections following aerosol challenge of mice (West et al., 2008). Because of the highly similar and syntenic genome, several studies used the closely related *B. thailandensis* as a surrogate to investigate *B. pseudomallei* virulence factors, such as T3SS (Haraga et al., 2008, French et al., 2011, Woodman et al., 2012). The aim of the work described in this



chapter was to evaluate the role of VacJ in *B. thailandensis*. The approach used was construction of unmarked VacJ deletion mutants ( BTH\_I3001 and BTH\_II2351) in *B. thailandensis* and characterize the mutants for phenotypic defects in the infection of cell lines and serum resistance.

## 5.2 Aims:

1. To generate unmarked, in frame deletions in *B. thailandensis* E264
2. To characterize the resulting mutants using *in vitro methods*

## 5.3 Results

### 5.3.1 Deletion of *Burkholderia thailandensis* putative VacJ homologues.

The cloning strategy used to produce the construct for deletion of *bth\_i3001* and *bth\_ii2351* was outlined in Figure 4.1. Primers were designed for performing splicing by overlapping extension PCR (SOE PCR), with engineered restriction sites (Chapter 2). Upstream and downstream flanking regions of *bth\_i3001* or *bth\_ii2351* were PCR-amplified from *B. thailandensis* E264 genomic DNA. For each gene, PCR products were used as the template in a subsequent PCR to produce a spliced DNA fragment (mutagenesis cassette). The mutagenesis cassette was cloned into pGEM-T Easy vector or pJET1.2 and the insert confirmed by nucleotide sequencing. The mutagenesis cassette was subcloned into the lambda (  $\lambda$  ) *pir* dependent vector pDM4. *E. coli* MFD colonies containing the deletion construct were confirmed by PCR and nucleotide sequencing of the insert DNA.

### 5.3.2 Mutant production

The mutagenesis strategy is outlined in Figure 4.2 (Logue et al., 2009). For mobilization of the pDM4 deletion construct into *B. thailandensis* by conjugation, overnight cultures of *E. coli* and *B. thailandensis* strains were spotted together on LB agar and grown overnight at 37°C. The first cross-over event resulted in the integration of the deletion construct into the host chromosome by homologous recombination. Integrants (merodiploids) were identified on LB agar containing chloroamphenicol (30 µg/ml) and confirmed by colony PCR.

A single integrant colony (merodiploid) was subcultured and plated on the counter-selective sucrose agar for selection of clones that underwent the second cross over event. Clones were screened for loss of chloramphenicol resistance and a deletion of the target gene by PCR analysis and sequencing. Sequencing results confirmed a 969 bp and 1038 bp in-frame deletion in the *bth\_i3001* and *bth\_ii2351* alleles respectively (Figure 5.1 to 5.4). The mutant strains are named *B. thailandensis* E264 BTH\_I3001 and *B. thailandensis* E264 BTH\_II2351.

Using similar methods outlined above, a double mutant ( BTH\_I3001 BTH\_II2351) was generated using the *B. thailandensis* E264 BTH\_II2351 as the parent strain. The mutant strain is named *B. thailandensis* E264 DB.

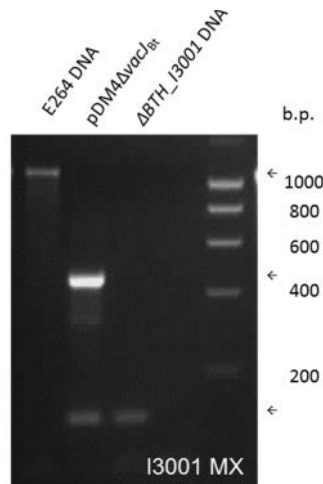

**Figure 5.1 Screening for *B. thailandensis* deletion mutant (E264 BTH\_I3001).**

Screening by multiplex PCR (I3001 MX) was performed using primers pDM4\_seqF, VacJ seqR3, BT\_VacJ\_L, BT\_VacJ\_R. After subjecting the merodiploid to the sucrose selection method, resultant Cm-sensitive colonies were screened via PCR for the absence of deletion construct DNA (117 bp and 462 bp) and the presence of a smaller PCR product that indicates the deletion of the target gene (mutant = 117 bp, wild type = 1086 bp).

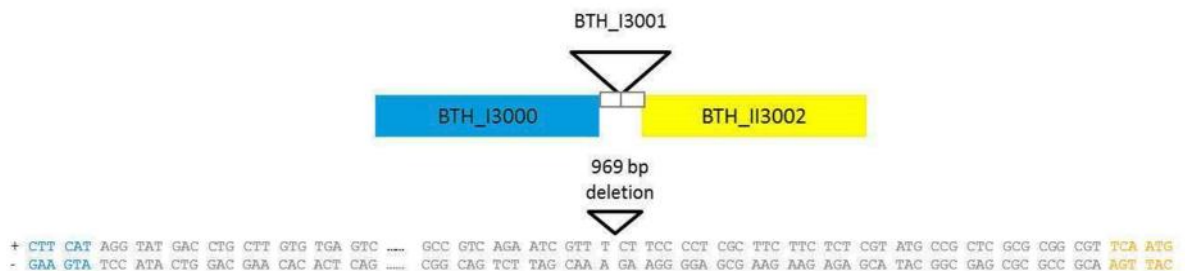

**Figure 5.2 Sequence of the *B. thailandensis* E264 BTH\_I3001 mutant surrounding the deleted region.**

The sequence in grey indicates the predicted intergenic regions where the deletion was made.

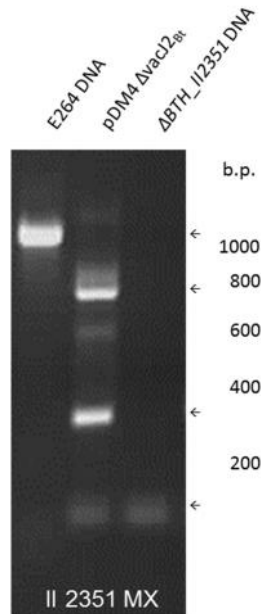

**Figure 5.3 Screening for *B. thailandensis* deletion mutant (E264 BTH\_II2351).**

Screening by multiplex PCR (II 2351 MX) was performed using primers pDM4\_seqF, VacJ2 seqR2, BT\_VacJ2\_L, BT\_VacJ2\_R. After subjecting the merodiploid to the sucrose selection method, resultant Cm-sensitive colonies were screened via PCR for the absence of deletion construct DNA (65 bp, 315 bp and 726 bp) and the presence of a smaller PCR product that indicates the deletion of the target gene (mutant = 65 bp, wild type = 1103 bp).

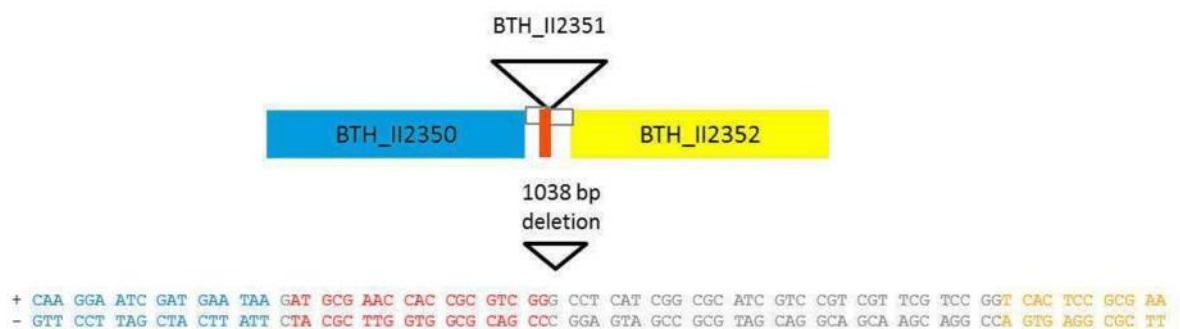

**Figure 5.4 Sequence of the *B. thailandensis* BTH\_II2351 mutant surrounding the deleted region.**

The sequence in grey indicates the predicted intergenic regions where the deletion was made.

### 5.3.3 Complementation of mutant strain

The gene *bth\_i3001* was PCR amplified from *B. thailandensis* E264 using primers 3001-DN-KpnI and 3001-UP-ApaI (with engineered restriction sites) (Chapter 2, Section 2.7), and cloned into multiple cloning site of pUT-mini-Tn5 Km2 at the *ApaI* and *KpnI* sites. The gene was excised from the vector at the *KpnI* and *EcoRI* sites and ligated into the shuttle vector pME6032 or pMEK (pME6032-derivative, Appendix). Ligations were transformed into *E. coli* Top10 and plated onto selective LB agar containing 50 µg/ml tetracycline (pME6032) or 400 µg/ml kanamycin (pMEK). Colonies containing the correct construct were confirmed by restriction digest, PCR and nucleotide sequencing.

The complementation construct was transferred to *B. thailandensis* BTH\_I3001 by electrotransformation using methods outlined in Choi *et al.* (2006) (Choi *et al.*, 2006). Briefly, electrocompetent *B. thailandensis* cells were prepared by washing cells twice in 300 mM sucrose solution at room temperature before use. Mutant bacteria containing the complementation plasmid were plated onto selective agar containing the appropriate antibiotics. Expression of BTH\_I3001 was induced by addition of 0.25 mM IPTG to bacterial broth cultures. The complemented mutant was named *B. thailandensis* BTH\_I3001 +pME VacJBT or *B. thailandensis* BTH\_I3001 +pMEK VacJBT.

### 5.3.4 Growth in media

The growth rate of *B. thailandensis* BTH\_I3001 and the double VacJ mutant *B. thailandensis* DB ( BTH\_I3001 BTH\_I12351) was determined in liquid media. Deletion of *bth\_i3001* or both *bth\_i3001* and *bth\_i12351* did not result in restricted growth in LB media (Figure 5.5).

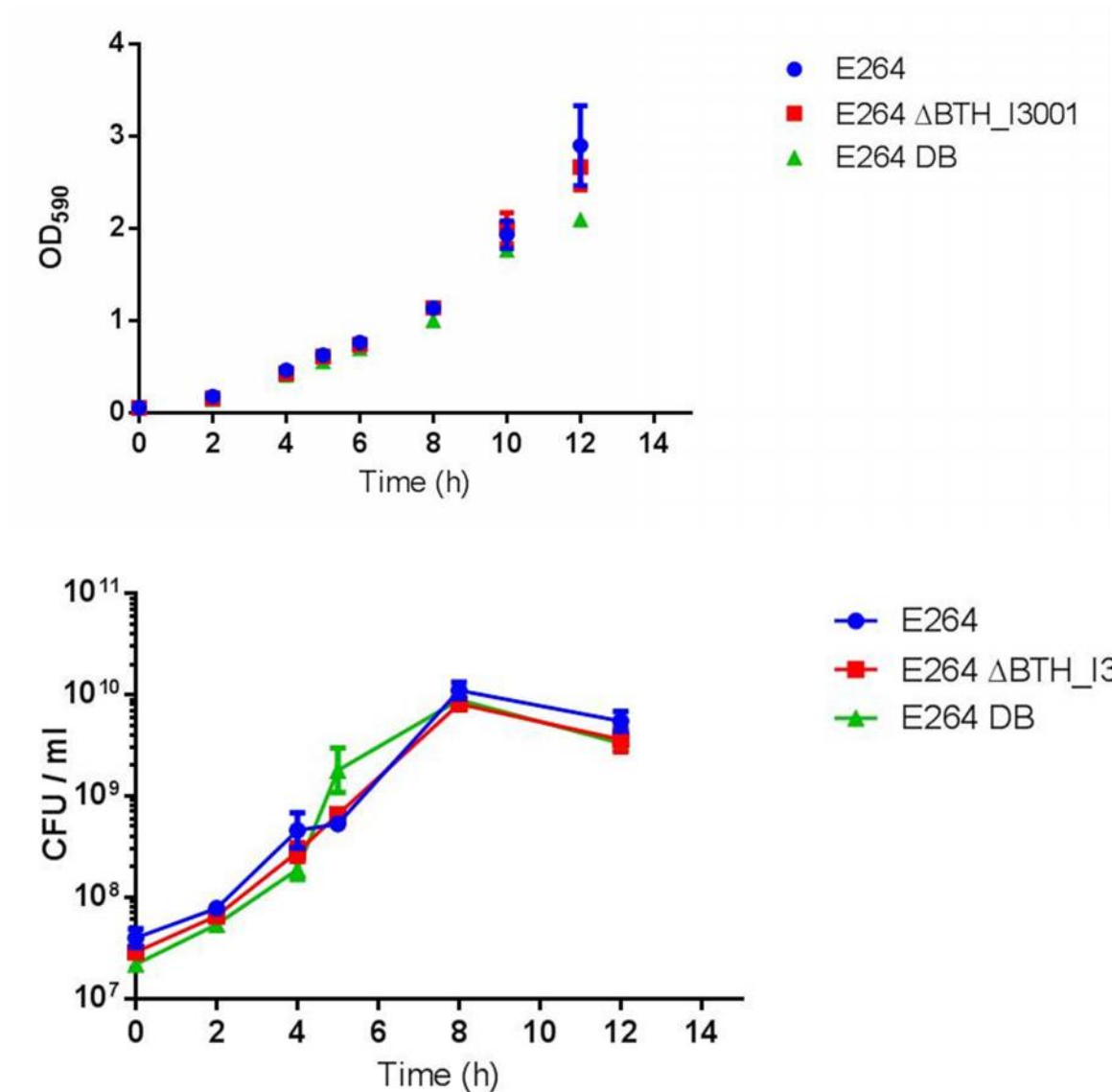

**Figure 5.5 Growth curves of *B. thailandensis* wild type and VacJ mutants in LB broth at 37°C.**

Growth was monitored by viable counts or absorbance at 590 nm over 12 h. Values are from a single experiment performed in triplicates.

### 5.3.5 Serum survival

VacJ plays a role in serum resistance in non-typeable *H. influenzae* (acapsular) (Nakamura et al., 2011). To investigate the role of VacJ in *B. thailandensis* in serum resistance, wild type and mutant strains were incubated in 30 % normal human serum (NHS) for 2 h and then enumerated by plate counting. For plasmid-complemented mutants, 0.25 mM IPTG was added for induction of VacJ expression. No viable *E. coli* were detected after 2 h incubation in 30 % NHS, demonstrating the killing activity of NHS.

In agreement with previous reports (Ismail et al., 1988, DeShazer et al., 1998, Reckseidler-Zenteno et al., 2005, Woodman et al., 2012, Egan and Gordon, 1996), the viability of the *B. thailandensis* wild type was unaffected by the addition of NHS, confirming the inherent resistance to serum bactericidal activity (Fig. 5.6). In contrast, the VacJ mutants ( BTH\_I3001 and DB) displayed significant susceptibility to the bactericidal effects of human serum. For the BTH\_I3001 mutant, there was a one-log decrease in colony-forming units upon incubation with NHS. The serum resistance phenotype was restored in the complemented mutant ( BTH\_I3001+pMEKVacJBT). For the double VacJ mutant (DB), the serum susceptibility is much more pronounced, as no bacteria were recovered after incubation with 30 % NHS. The double mutant complemented with pMEKVacJBT displayed a partial restoration of the serum resistance phenotype. Direct killing of *E. coli* and *B. thailandensis* mutants was not observed in heat-inactivated serum (Hi-NHS), indicating the mechanism is mediated by heat labile components in serum (complement) (Figure 5.6).

As the LPS of the BTH\_I3001 mutant did not appear to be altered as the mutant was able to bind to anti-LPS antibodies (Figures 5.9-5.11), it is likely that VacJ is an additional factor that affects serum resistance. This is analogous to the phenotype observed in the acapsular *B. pseudomallei* VacJ mutant. Interestingly, the double VacJ mutant (E264 DB) was more pronounced in susceptibility to bactericidal effects of human serum. A further investigation revealed that while the wild type and the BTH\_I3001 mutant remained resistant to polymyxin B up to 128 mg/ml, the double VacJ mutant was less resistant to polymyxin B (MIC: 32 mg/ml, Table 5.1). Polymyxin B acts like cationic detergents, interacts with the lipopolysaccharide of the cytoplasmic outer membrane of Gram-negative bacteria (Zavascki et al., 2007), or inhibits respiratory enzymes in the bacterial inner membrane (Deris et al., 2014), altering membrane permeability and causing cell death. Expression of BTH\_I3001 in E264 DB did not complement the polymyxin B resistance phenotype.



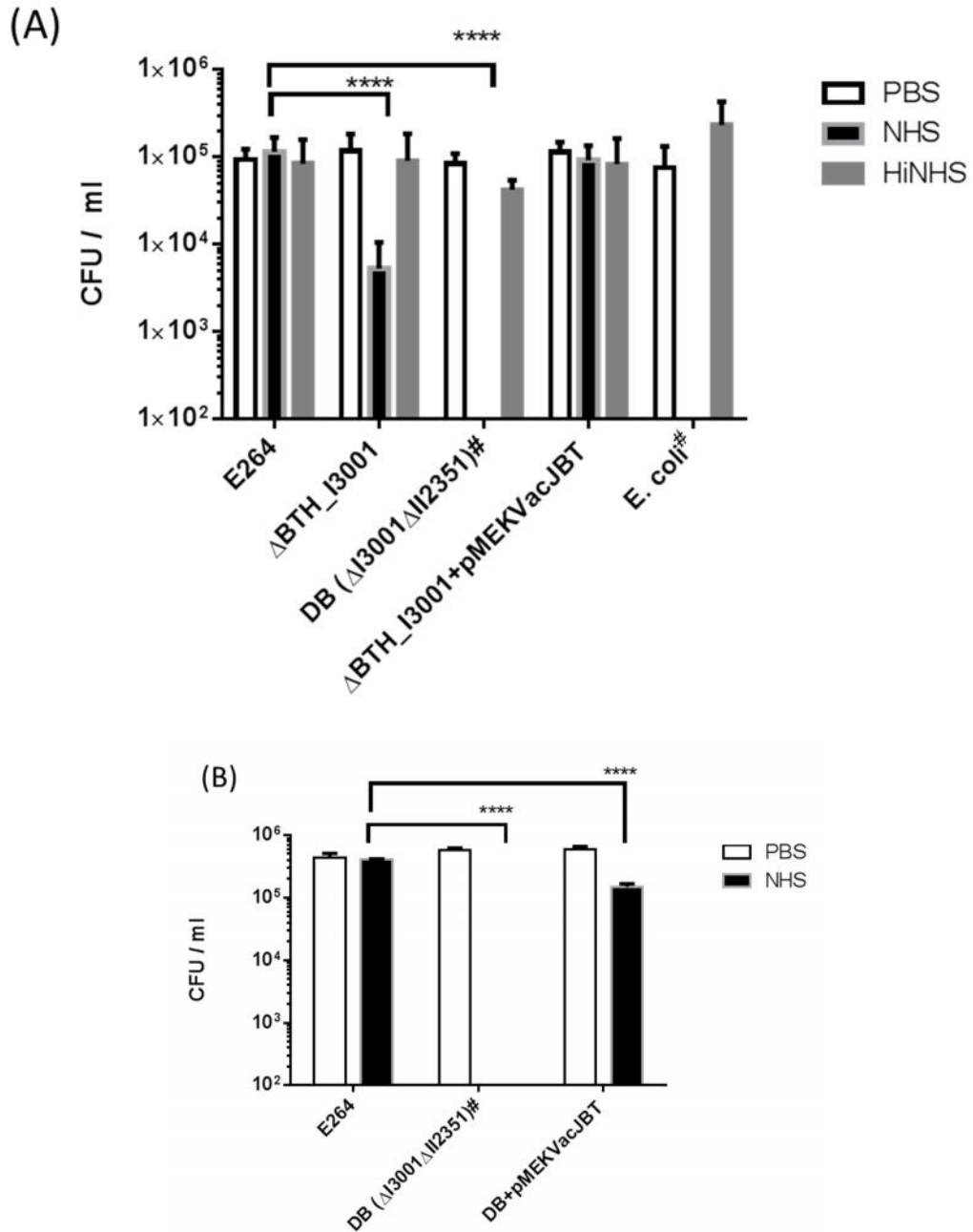

**Figure 5.6 Serum survival assay for *B. thailandensis*.**

Bacteria was incubated for 2 h at 37 °C with PBS, 30 % pooled complement human serum (30% NHS, Patricell, UK) or heat inactivated NHS (HiNHS). Bacterial colony forming units (CFU) were enumerated by serial dilution and plating onto LB agar. (A) The bars represent the mean values from three separate experiments  $\pm$  standard deviation, each carried out in duplicates. Bacterial counts for the strains incubated with heat-inactivated NHS were similar to that of the PBS control. (B) The bars represent the mean values from an experiment carried out in triplicate  $\pm$  standard deviation. \*\*\*\*  $p < 0.0001$  by unpaired Student's *t*-test comparing means of bacterial counts. # No colonies were recovered after incubation with 30% NHS (limit of detection 100 CFU / ml).

**Table 5.1 Minimal inhibitory concentration (MIC) of antibiotics on *B. thailandensis***

Antibiotic	E264	BTH_I3001	DB	BTHI_3001 + pMEK VacJBT	DB + pMEK VacJBT
Polymyxin B (mg/ml)	>128	>128	32	>128	32
Ceftazidime (µg/ml)	2	2	2	2	2

### 5.3.6 Infection of mammalian cell lines

Similar to *B. pseudomallei*, *B. thailandensis* can survive and replicate in a range of cell lines and adopt an intracellular life cycle (Jones 1996, Harley 1998). To determine if VacJ is required for intracellular growth and survival, I compared the *B. thailandensis* BTH\_I3001 mutant to the wild type strain for their abilities to invade, replicate and spread within cultured cell monolayers.

#### 5.3.6.1 Growth in J774 macrophages

J774A.1 murine macrophages were infected with *B. thailandensis* E264 wild type or BTH\_I3001 mutant strains at MOI of 10. After incubation for 1 h to allow uptake of bacteria, extracellular bacteria were killed with 250 µg/ml kanamycin. Infected cells were lysed at different time points and the number of viable bacteria within the cells was determined (Figure 5.7).

Following infection of J774A.1 macrophages with the wild type *B. thailandensis* E264 or the *B. thailandensis* BTH\_I3001 mutant, both strains were taken up into the cell in similar numbers (Figure 5.7a). There were no

significant differences in the invasion and the intracellular replication of the mutant strain in J774A.1 macrophages up to 12 h post-infection. However, at 24 h post infection, there were 7-fold fewer mutant bacteria present when compared to the wild type strain (Figure 5.7b,  $p < 0.001$ ). The plasmid-complemented mutant displayed partial restoration of the intracellular survival phenotype at 24 h post infection (Figure 5.7b,  $p < 0.011$  when compared to the wild type strain).

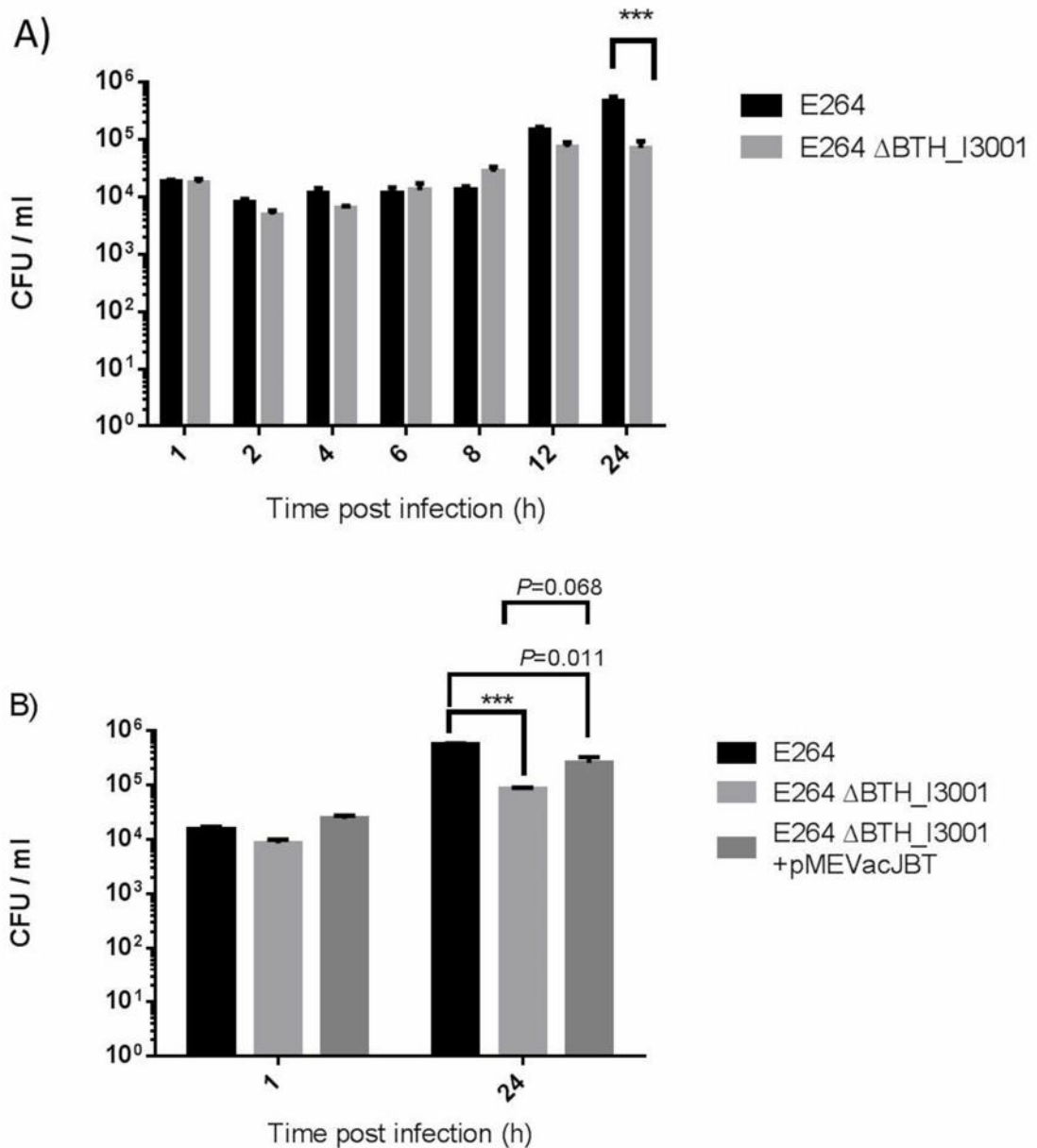

**Figure 5.7 Intracellular replication of *B. thailandensis* E264 wild type or the BTH\_I3001 mutant strain in J774A.1 macrophages.**

Cells were incubated with bacteria for 1 h at an MOI of 10, after which the monolayers were washed and kanamycin (250  $\mu$ g/ml) was added to the media to suppress the growth of extracellular bacteria. Intracellular bacterial numbers were determined at (A) 2, 4, 6, 8, 12 and 24 h after infection. Each bar represents the mean values from triplicate experiments  $\pm$  standard errors. (B) Cells were infected with *B. thailandensis* E264 wild type, BTH\_I3001 mutant or complemented mutant ( BTH\_I3001 + pMEVacJBT). Values shown are mean values  $\pm$  standard errors from a single experiment performed in triplicates.

The asterisk indicates that the data differs significantly from the wild type strain (\*\*\*:  $p < 0.001$  by Student's *t*-test).

### 5.3.6.2 Adherence to A549 epithelial cells

The A549 human epithelial cell lines were infected with *B. thailandensis* E264 wild type or *B. thailandensis* mutants ( BTH\_I3001 and DB) at MOI of 5. At 2 h post infection, infected cells were lysed and the number of viable bacteria within the cells was determined (Figure 5.8). There were no significant differences between the wild type strain and the VacJ mutants for adherence into A549 epithelial cells.

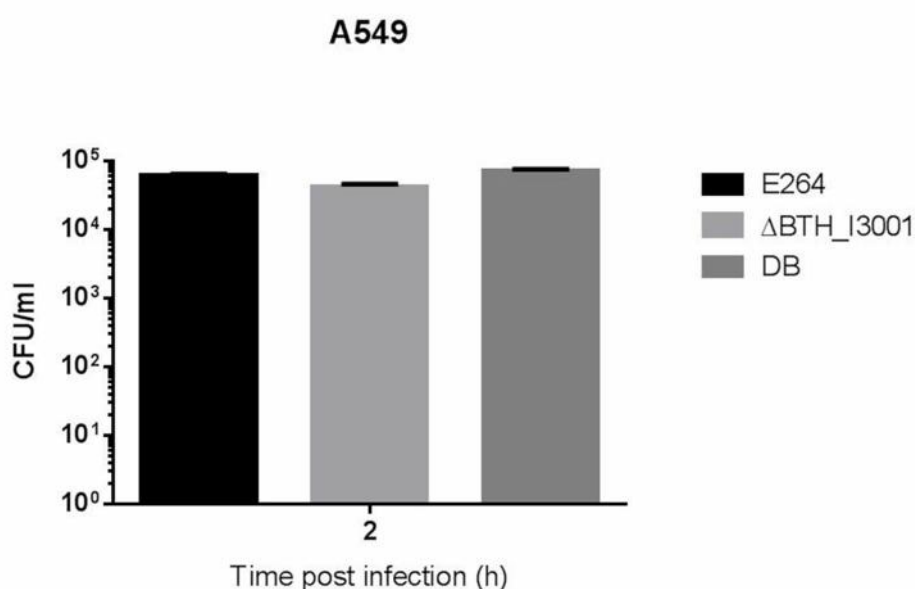

**Figure 5.8 Adherence of A549 epithelial cells by *B. thailandensis* wild type or VacJ mutants ( BTH\_I3001 and DB).**

The mean bacterial recoveries (CFU/ml)  $\pm$  standard error of mean (SEM) at 2 h post infection (MOI 5) are shown. Data is representative of 2 experiments, performed in duplicates. No significant differences were observed between the strains (One-way ANOVA).

### 5.3.6.3 Escape from endocytic vacuoles, evasion of autophagy and actin polymerization

The defect in intracellular survival of the *B. thailandensis* BTH\_I3001 mutant may be associated with the intracellular behaviour of the bacteria. Following invasion, *B. thailandensis* escapes from endocytic vesicles by lysing endosome membranes and avoid degradation through the lysosomal system (Harley et al., 1998, Haraga et al., 2008). The bacteria avoid host autophagic attack, where a portion of cytoplasm becomes enclosed within an isolation membrane (phagophore), generating a double membrane vesicle (autophagosome) that subsequently fuses with endosome and lysosome, targeting the contents for degradation (Ravikumar et al., 2010). *B. pseudomallei* and *B. thailandensis* are able to induce cellular actin rearrangement and membrane protrusions for intracellular and intercellular motility (Kespichayawattana et al., 2000, French et al., 2011).

J774A.1 murine macrophages were infected with *B. thailandensis* E264 wild type or BTH\_I3001 mutant strains as described before and the co-localization with mammalian cell markers was examined. The cells were fixed at 6 h post infection and observed using confocal microscopy for bacterial association with the lysosome marker, LAMP-1 (lysosome-associated membrane glycoprotein-1) (Figure 5.9) and the autophagy marker LC3b (microtubule-associated protein 1A/1B-light chain 3) (Figure 5.10). LC3 recruitment to phagosomes stimulates bacterial killing (D’Cruze et al., 2011). The results showed that both the intracellular wild type and BTH\_I3001 mutant strain were rarely associated with the LAMP-1 or the LC3b in

J774A.1 cells at 6 h post infection, indicating both strains possess similar abilities to evade the host lysosomal and autophagic degradation system.

At 8 h post infection, cells were fixed and observed using fluorescence microscopy for bacterial association with filamentous actin (F-actin) (Figure 5.11). Both the *B. thailandensis* wild type and BTH\_I3001 mutant formed typical actin tails at one pole of the bacterium, an indication of successful escape from endosomes. The bacteria also appeared to be forming membrane protrusions for intercellular spread. This demonstrates that VacJ was not involved in actin-based motility.

#### **5.3.6.4 Multinucleated giant cell (MNGC) formation**

Like *B. pseudomallei* and *B. mallei*, *B. thailandensis* is able to induce cell fusion and the production of MNGCs for the spread of bacteria from cell-to-cell (Harley et al., 1998, Kespichayawattana et al., 2000, Wand et al., 2011, French et al., 2011). A cell was considered to be a MNGC if there were three or more nuclei present. The ability of the bacteria to induce MNGC formation is predicted to be important for the evasion of host immune responses, persistence of *B. pseudomallei* within host or even access to nutrients in uninfected macrophages (Galyov et al., 2010, Burtnick et al., 2011).

At 8 h post infection, MNGC formation was observed in J774A.1 murine macrophages infected with either the wild type or mutant *B. thailandensis* (Figure 5.12). Giemsa staining of infected macrophages was performed to assess the level of MNGC formation at later time points. At 16 h post infection, large multinucleated giant cell formation (> 20 nuclei) was observed

in macrophages infected by wild type *B. thailandensis* E264, while numerous but smaller giant cells (fewer nuclei) were observed in those infected by the *B. thailandensis* BTH\_I3001 mutant. The BTH\_I3001 mutant was less able to form giant cells at 16 h post infection, but the level of MNGC formation increased by 24 h post infection.



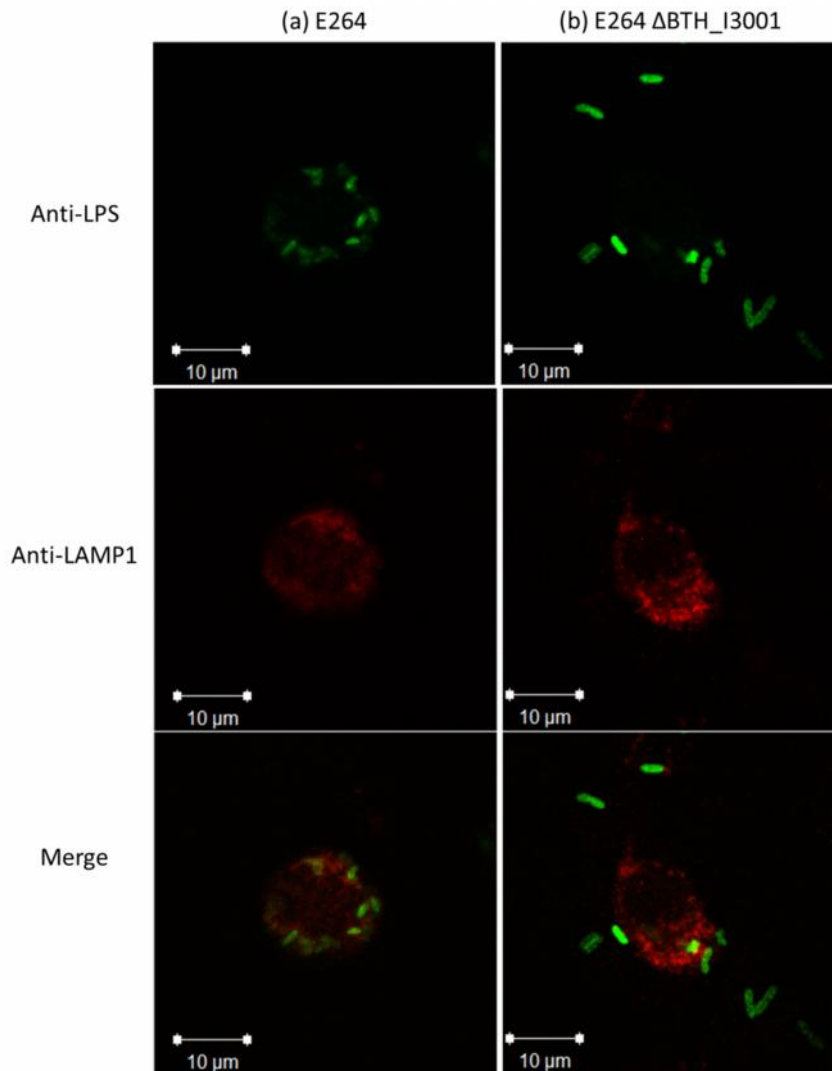

**Figure 5.9 Association of intracellular *B. thailandensis* with LAMP-1.**

Confocal micrographs showing the association of intracellular *B. thailandensis* wild type or the BTH\_I3001 mutant strain with vesicles containing LAMP-1 in J774A.1 cells 6 h post infection (MOI 10). Bacteria were stained with MAb anti-*B. pseudomallei* LPS (CC6) and anti-mouse Ig-Alexa Fluor488 (green). LAMP-1 was labelled with rat anti-LAMP-1 (ID4B) and anti-rat Ig-Cy5 (red) antibodies (magnification x630). Extracellular bacteria were killed with kanamycin and removed by extensive washing before staining. Bacteria were confirmed to be located in an intracellular niche by viewing optical sections above and below the plane of focus. The wild type and BTH\_I3001 mutant bacteria were rarely seen in association with regions of LAMP-1 labelling.

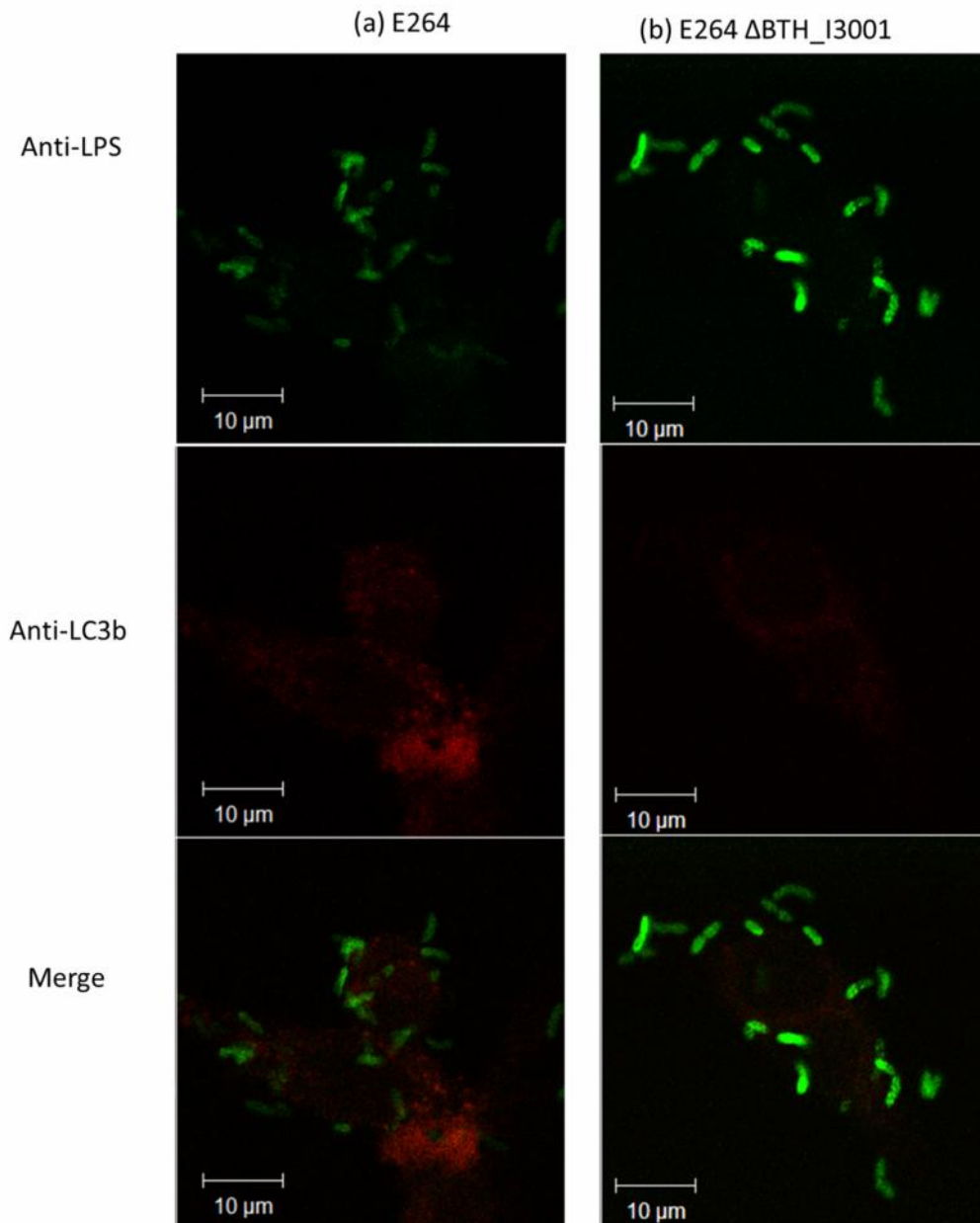

**Figure 5.10 Association of intracellular *B. thailandensis* with autophagy marker LC3b.**

Confocal micrographs showing the association of intracellular *B. thailandensis* wild type or the BTH\_I3001 mutant strain with the autophagy marker protein LC3b in J774A.1 cells 6 h post infection (MOI 10). Bacteria were stained with MAb anti-*B. pseudomallei* LPS (CC6) and anti-mouse Ig-Alexa Fluor488 (green). LC3b was stained with rabbit anti-LC3b and anti-rabbit Ig-AlexaFluor594 (red) (magnification x630). Extracellular bacteria were killed with kanamycin and removed by extensive washing before staining. The wild type and BTH\_I3001 mutant bacteria were rarely seen in association with regions of LC3b staining.

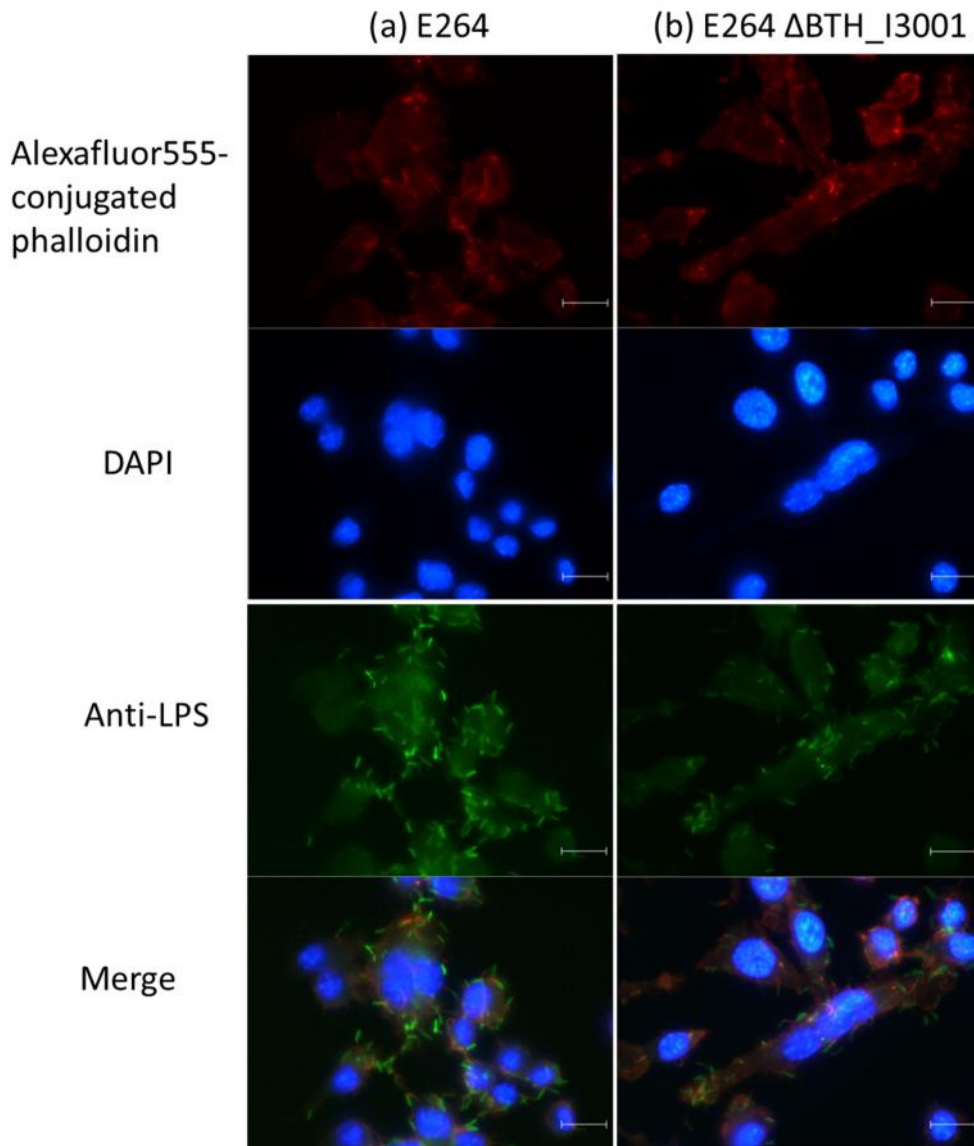

**Figure 5.11 Association of *B. thailandensis* with F-actin.**

Visualization of actin tail polymerization by *B. thailandensis* strains using fluorescence light microscopy. J774A.1 macrophages were infected with (a) *B. thailandensis* E264 or (b) BTH\_I3001 mutant for 8 h at an MOI of 10. Bacteria were stained for LPS with MAb CC6 and anti-mouse Ig-Alexa Fluor488 (green). Filamentous actin (F-actin) was labeled with Alexa Fluor 555-conjugated phalloidin (red). Mammalian cell nuclei were stained using DAPI. Scale bars: 14  $\mu$ m.

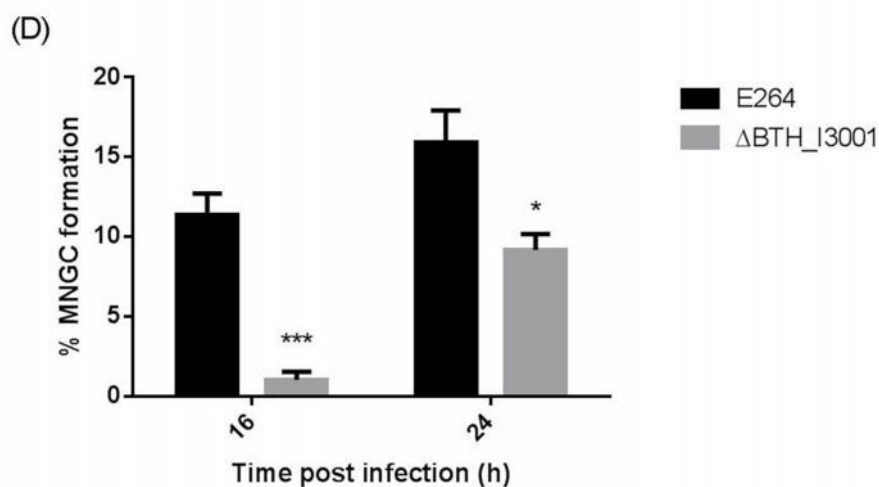
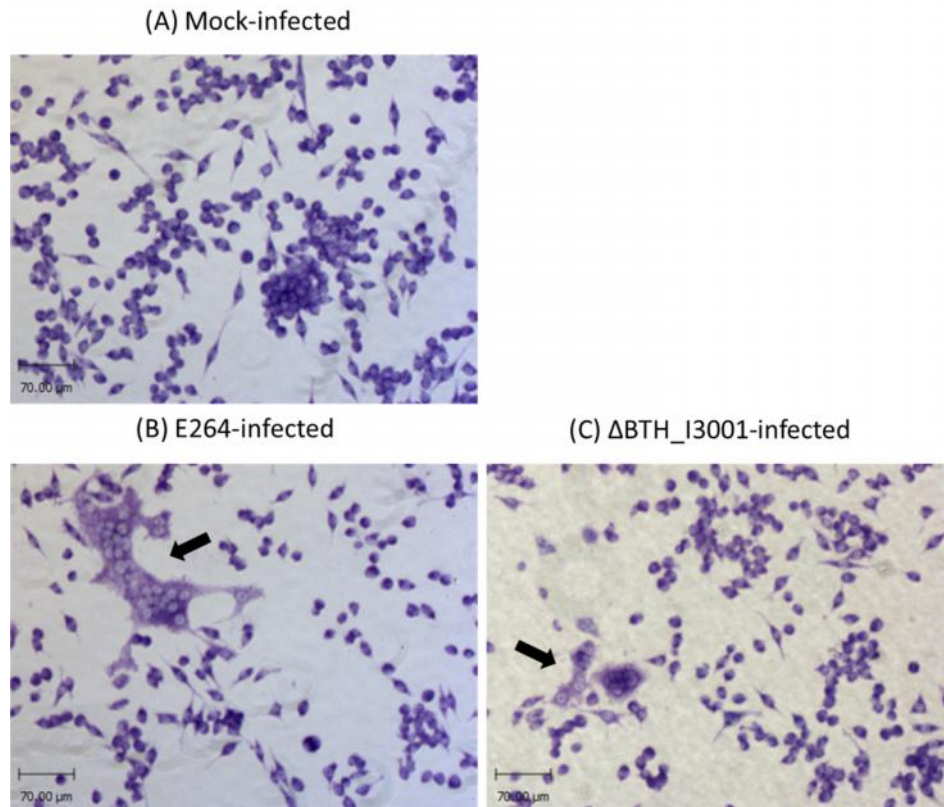

**Figure 5.12 MNGC formation in J774A.1 murine macrophages.**

Cells were (A) mock-infected or infected with (B) *B. thailandensis* E264 or (C) the BTH\_I3001 mutant at an MOI of 10 for 16 h and stained with Giemsa. Arrows indicate the multinucleated giant cell formation (MNGC) containing three or more nuclei. Scale bars = 70 μm. The micrographs are representative of two independent experiments. (D) The percentage of MNGCs was calculated relative to normal macrophages at 16 h and 24 h post-infection. The error bars represent the standard error of the mean derived from at least nine fields of view at 10 x magnification.

## 5.4 Discussion

*B. thailandensis* share extensive genome similarity with *B. pseudomallei* and exhibits a similar intracellular lifestyle (Kim et al., 2005b, Yu et al., 2006). Although *B. thailandensis* is able to cause lethal inhalational infections in mice at high doses ( $3 \times 10^4$  CFU deposited / lung) (West et al., 2008), it is considered as relatively avirulent in human and it rarely causes human disease (Lertpatanasuwun et al., 1999, Glass et al., 2006). Because of the relative avirulence of *B. thailandensis*, the containment requirements are much less stringent than that for *B. pseudomallei*, rendering it more accessible for manipulation in the laboratory setting. Several studies have used *B. thailandensis* as a surrogate model system to investigate various aspects of *B. pseudomallei* biology (Haraga et al., 2008, Chandler et al., 2009). However, it is important to consider the differences between the two species before extrapolating the data to *B. pseudomallei* (French et al., 2011).

*B. thailandensis* E264 genome encodes many orthologues of known and putative *B. pseudomallei* virulence determinants, including the VacJ orthologue, BPSL3147. BPSL3147 was shown to be required for *in vivo* virulence and share homology with *S. flexneri* VacJ, *E. coli* MlaA and *H. influenzae* VacJ. Similar to that in *B. pseudomallei*, orthologues to genes encoding the Mla proteins in *E. coli* are found in close proximity to *bth\_i3001*. Like *B. pseudomallei*, a second *vacJ* homologue is found in chromosome 2 of *B. thailandensis* E264 (*bth\_ii2351*).

In this study, unmarked in-frame VacJ deletion mutants of *B. thailandensis* E264 were constructed using a similar strategy for making deletion mutants in *B. pseudomallei* (Logue et al., 2009). Using the deletion mutants, I investigated factors that could affect bacterial fitness during mammalian infection, such as sensitivity to human sera. The *B. thailandensis* VacJ mutants displayed reduced serum resistance compared to the wild type strain. The complement system plays an integral role in host innate immune system in killing pathogenic microorganisms. Activation of the various complement pathways (classical, lectin, and the alternative pathways) are triggered by various proteins that recognise bacterial ligands, and lead to the deposition of opsonins and/or assembly of pore-forming membrane attack complex (MAC) on microbial surfaces and lead to bacterial elimination. The O-polysaccharide (O-PS) moiety of the *B. pseudomallei* LPS is essential for outer membrane integrity and complete serum resistance, although the mechanism for resistance to direct killing by complement is not fully understood (DeShazer et al., 1998, Reckseidler-Zenteno et al., 2005, Woodman et al., 2012). It was suggested that *B. thailandensis* could display similar serum-resistance mechanisms with *B. pseudomallei* because of the similarities in the O-PS structure (Woodman et al., 2012). Since the BTH\_I3001 mutation did not affect the LPS, it is likely that VacJ is a novel factor that affects serum resistance. Interestingly, a double knockout mutant (*B. thailandensis* DB) displayed complete susceptibility to bactericidal effects of human serum and partial serum resistance can be restored with a trans-complementation of *bth\_i3001*. It is possible that the knockout of the *vacJ* homologue (*bth\_ii2351*) affected the LPS; contributing to a defect in

resistance to serum and polymyxin B. Future work to complement both genes in the double mutant would help to elucidate the function of both *vacJ* genes in *B. thailandensis*.

During *in vitro* infections, the *B. thailandensis* BTH\_I3001 mutant did not display any defects for invasion of epithelial cells or uptake by macrophages, and was able to replicate intracellularly during initial phases of infection. However, the same BTH\_I3001 mutant exhibited reduced intracellular numbers in J774A.1 macrophages after 24 h. This could be due to an intracellular bacterial growth defect at later time point, an inability to overcome host intracellular defence mechanisms, or due to the destruction of the macrophage monolayer at late time points, resulting in less intracellular bacteria numbers. A cytotoxicity test, such as measurement of the lactate dehydrogenase (LDH), should be used to rule out the latter possibility.

The number of bacteria at the initial time points post infection was similar for both the *B. thailandensis* E264 wild type and the BTH\_I3001 mutant, so the distinct phenotypes could not be explained by differences in its uptake by phagocytes, indicating that BTH\_I3001 may be involved in other intracellular events by modulating the phagocytic compartment.

In *B. pseudomallei* and *B. thailandensis*, the T3SS is associated with escape from the endosome, which influences downstream events such as cell fusion and intercellular spread and replication (Haraga et al., 2008, French et al., 2011). The T6SS-1 functions downstream of invasion and endosome escape, and facilitate intercellular spread by fusing cell membranes or killing cells by compromising membrane integrity. Both the wild type and the BTH\_I3001

mutant escaped from vacuoles, formed actin tails and induced MNGC formation. However, at later time points of infection, the ability for the BTH\_I3001 mutant to form giant cells appeared to be delayed. This may have contributed to the reduced intracellular growth at later time points of infection due to the delayed ability to access nutrient rich, uninfected macrophages through cell-to-cell spread and fusion. The mechanisms behind the delayed ability for giant cell formation by the *B. thailandensis vacJ* mutant remain to be elucidated. In *S. flexneri*, the *vacJ* mutant has a defective outer membrane, was able to spread within the cytoplasm of the primary infected epithelial cells, but was less efficient in its release from vacuoles after cell-to-cell spread (Suzuki et al., 1994, Carpenter et al., 2014). Although the mechanisms by which the VacJ protein functions for *Shigella* intercellular spread remains to be elucidated, Carpenter *et al.* hypothesized that the outer membrane protein may act in one or more ways, including: assembly of the T3SS in the membrane, the secretion of effector proteins of intracellular bacteria or the signalling activities via the proposed ABC transporter activity for the eventual lysis of vacuoles (Carpenter et al., 2014). Since no defect is observed in the escape from endosomes, it is unlikely that VacJ affects the T3SS. It is possible that VacJ affects the assembly of T6SS or secretion of T6SS effectors that affects cell fusion. Alternatively, the mutation of BTH\_I3001 may result in alteration of outer membrane properties such as presentation of cell surface antigens that lead to differential host immune responses which may affect bacterial viability, or reduced resistance to other host defence mechanisms such as antimicrobial peptides.



In conclusion, a VacJ orthologue, encoded by *bth\_i3001*, represents a novel virulence determinant in *B. thailandensis*. Like the non-typeable *H. influenzae*), inactivation of *vacJ* increased sensitivity to human serum, suggesting a defect in outer membrane and resistance to complement deposition. This phenotype is similar to that of the acapsular *B. pseudomallei* VacJ mutant ( BPSL3147). The presence of a second *vacJ* homologue in both *Burkholderia* species suggests there may be functional redundancy, as highlighted in the serum sensitivity assay. The BTH\_I3001 mutant exhibited reduced survival and MNGC formation in macrophages during late intracellular events. These intracellular defects were not observed in the BPSL3147 mutant in *B. pseudomallei*, which highlights the need for caution in extrapolating data derived with *B. thailandensis* for *B. pseudomallei*. The difference in observed phenotypes for serum resistance and intracellular fitness may be due to the presence of the capsule in *B. pseudomallei* or other inherent differences between the two strains.

## Chapter 6 – General Discussion and Future Work

With the emergence of melioidosis cases around the world (Currie 2008), there is a growing need to better understand the nature of pathogenesis of *B. pseudomallei* in order to devise rational strategies for the treatment of this disease. Currently there is no vaccine available against melioidosis and the infections can be difficult to treat due to the resistance of the bacteria to multiple antibiotics and the ever-changing nature of disease manifestations (Cheng 2005). The development of new vaccines and antimicrobials will benefit from a more thorough understanding of mechanisms of resistance. A key first step in this process would involve the identification of novel virulence determinants, followed by further characterization for the basis of virulence and function (Wu et al., 2008).

Some strategies for the large scale screening for novel virulence determinants in *B. pseudomallei* have been developed (Atkins et al., 2002a, Cuccui et al., 2007, Moule et al., 2014). In a study that screened for transposon mutants defective for intercellular spreading, genes involved in the purine, histidine and *para*-aminobenzoate biosynthetic pathways were found to be important for intracellular replication and survival, which leads to intercellular spread (Pilatz et al., 2006). In a signature tagged mutagenesis (STM) screen comparing microarray signals from mutant pools before and after mice infection, genes involved in amino acid synthesis pathway (*aroB*), capsular polysaccharide synthesis (*wcbC*) and putative lipoprotein VacJ (*bps/3147*) were identified to be important for *in vivo* virulence (Cuccui et al., 2007). The attenuation of the *aroB* and *wcbC* mutants was confirmed in a

separate mouse infection experiment (Cuccui et al., 2007). The capsular polysaccharide has been shown to be important for virulence and contributes to serum resistance (DeShazer et al., 1998, Woodman et al., 2012). A TraDIS experiment that resequenced the STM library (Cuccui et al., 2007) provided a quantitative measure of fitness scores, and revealed the attenuation of *in vivo* virulence for these mutants (Moule and Cuccui, unpublished data, Chapter 3). Lipoproteins may play diverse roles, including those in pathogenesis (Kovacs-Simon et al., 2011). The correlation of the VacJ lipoprotein to *in vivo* virulence presented a novel opportunity to investigate the role of this putative lipoprotein in *B. pseudomallei* pathogenesis. The putative lipoprotein VacJ (BPSL3147) identified by Cuccui et al. 2007 was further studied and became the focus of the present thesis.

The role of VacJ in *B. pseudomallei* was evaluated in Chapter 4 by construction of a deletion mutation in *bpsl3147*. In this work, I had first validated the attenuation of the BPSL3147 mutant by infecting mice with the transposon mutant 7A1 and a defined, non-polar deletion mutant (K96243 BPSL3147), and showed that both mutants were attenuated in mice. I then investigated the kinetics of infection of the deletion mutant (K96243 BPSL3147) and found that the mutant was able to replicate to wild-type levels in mice lungs within the first day, but was unable to sustain the infection beyond day 2 of infection.

I hypothesized that the attenuation of the VacJ mutant may be due to a defect in intercellular spreading, serum resistance and/or outer membrane stability as observed in similar mutants of other bacteria (Suzuki et al., 1994, Malinverni and Silhavy, 2009, Nakamura et al., 2011). As *B. pseudomallei* is

considered as an ACDP category three pathogen which requires strict biocontainment conditions, I have also constructed VacJ deletion mutants in the relatively avirulent *B. thailandensis* as an accessible surrogate to model melioidosis (West et al., 2008, Haraga et al., 2008) (Chapter 5).

Reminiscent of the *S. flexneri* VacJ mutant (Carpenter et al., 2014, Suzuki et al., 1994), the *B. thailandensis* BTH\_I3001 mutant was able to escape from the endosomes, polymerise actin and replicate intracellularly (Chapter 5). The *B. thailandensis* BTH\_I3001 appeared to have a defect in intercellular spread, as evidenced by the delay in MNGC formation (Chapter 5). In contrast, I found no obvious defect in the *B. pseudomallei* K96243 BPSL3147 mutant for the major components of the *Burkholderia* intracellular lifestyle, including invasion, intracellular survival, and MNGC formation (Chapter 4).

To spread intercellularly, *S. flexneri* propels itself via actin polymerization through the host cytoplasm and into a protrusion of a double membrane barrier, forming a vacuole between two host cells. It would then lyse the vacuole in the recipient cell, where the intracellular lifecycle repeats. The *S. flexneri* VacJ mutant was less able to lyse the double membrane vacuole through undefined mechanisms (Suzuki et al., 1994, Carpenter et al., 2014). Although *B. pseudomallei* and *B. thailandensis* exhibit cytoplasmic motility which promotes contact with cell membranes and formation of membranous protrusions (Stevens et al., 2006, Galyov et al., 2010), several studies proposed that the primary mechanism of cell-to-cell spread involves cell fusion mediated by the activity of a T6SS, leading to the formation of MNGCs (Burtnick et al., 2011, French et al., 2011, Toesca et al., 2014). The

underlying mechanisms behind the delayed MNGC formation and defective intracellular survival of the *B. thailandensis* BTH\_I3001 mutant remain unclear as there was no apparent defect in the early stages of the intracellular cycle, including uptake, escape from endosomes, and actin polymerization. Mutation of BTH\_I3001 may have affected the proper assembly of the T6SS, or the timing of secretion of the effector proteins, which in turn, can influence the fusogenic properties of *B. thailandensis*. Alternatively, the *B. thailandensis* BTH\_I3001 mutant may have a defect in escape from the double membrane vacuole following cell-to-cell spread via membranous protrusions, but retains fusogenic activity. A third hypothesis is that mutation of BTH\_I3001 affects the bacterial outer membrane, which may result in the alteration of presentation of cell surface antigens to the host immune system, or may render the bacteria less resistant against host defence mechanisms such as antimicrobial peptides. The difference in intracellular phenotypes between the *B. pseudomallei* and *B. thailandensis* VacJ mutants may be due to the presence of a capsule in *B. pseudomallei*, which may contribute to resistance against intracellular killing (Wikraiphath et al., 2009). The intracellular survival defect in the *B. thailandensis* BTH\_I3001 mutant may be due to increased susceptibility to intracellular killing or the delayed ability to access nutrient rich macrophages through fusion and cell-to-cell spread. This study also highlights the risk of using *B. thailandensis* as a surrogate for studying melioidosis.

In consideration of future work, studies could involve construction of an unmarked, acapsular *B. pseudomallei* VacJ (BPSL3147) mutant or a VacJ mutant using the capsular *B. thailandensis* E555 (Sim et al., 2010) as a

parent strain for comparison of intracellular phenotypes. It would be interesting to determine if the VacJ mutants elicit any differential host responses, such as reactive oxygen species (ROS) production or immunological markers, which may contribute to intracellular killing and clearance of bacteria.

Serum resistance, a complex phenotype determined by multiple elements, is an important virulence trait that allows the evasion of the host innate immunity mechanisms. A recent paper identified 56 genes in the serum resistome of an uropathogenic *E. coli* EC958 using TraDIS (Phan et al., 2013). The gene list included those involved in LPS biosynthesis (O-antigen and lipid A core biosynthesis), as well as those encoding lipoproteins, membrane proteins, regulators and hypothetical proteins. Although the LPS (lipid A core and O-antigen) was crucial for serum resistance in *E. coli* EC958, non-LPS genes such as *lpp* (encodes murein lipoprotein), *bamB* (encodes BamB lipoprotein), genes encoding for proteins that make up the Tol-Pal system (for maintenance of the outer membrane integrity) were also important for serum resistance. For *B. pseudomallei*, the LPS and the capsule contributes to serum resistance, with the former absolutely required for complete resistance (DeShazer et al., 1998, Reckseidler-Zenteno et al., 2005, Woodman et al., 2012). Woodman *et al.* (2012) suggested that the LPS attracts C3 deposition but does not allow membrane attack complex (MAC) formation, and the similarity in the O-antigen of *B. pseudomallei* and *B. thailandensis* may represent a common serum-resistance mechanism between these closely related species (Woodman et al., 2012). As demonstrated with the presence of non-LPS genes in the serum resistome of

the uropathogenic *E. coli*, it is likely that there are other factors that contribute to evasion of complement-mediated lysis in *B. pseudomallei* and *B. thailandensis*.

One major finding of this work is that VacJ affects the resistance of *B. pseudomallei* and *B. thailandensis* to human serum. In this work, I have shown that the *B. thailandensis* VacJ mutant (E264 BTH\_I3001), but not the *B. pseudomallei* VacJ mutant (K96243 BPSL3147), was susceptible to human serum. I hypothesized this was due to the presence of a capsule in *B. pseudomallei*, which may reduce complement deposition on the bacterium's surface (Reckseidler-Zenteno et al., 2005), and shown that an acapsular *B. pseudomallei* VacJ mutant (13H8 BPSL3147) was susceptible to human serum. This finding also emphasizes the importance of the capsule in contributing to serum resistance. In future work to confirm the serum sensitive phenotype of the acapsular *B. pseudomallei* VacJ mutant, an unmarked double mutant with the deletion of the capsule could be constructed in the *B. pseudomallei*, and complemented by introduction of a wild type copy of *bpsl3147*. Alternatively, purified preparations of BPSL3147 may be added to the serum killing assay to determine if the presence of BPSL3147 increases the survival of 13H8 BPSL3147.

The disruption of both VacJ homologues in *B. thailandensis* resulted in complete susceptibility to serum, suggesting that VacJ is a novel determinant for serum resistance, particularly for *B. thailandensis*. Future work could include characterizing the double VacJ mutant in *B. thailandensis*, such as examination of the LPS profile and pathogenesis. A double mutant with disruptions to both *vacJ* homologues in *B. pseudomallei* was not constructed

at this point. Alternative strategies such as construction of conditional mutants may be employed for future work (Moule et al., 2014).

Future studies could investigate the specific mechanisms by which VacJ functions in *B. pseudomallei* and *B. thailandensis*. For example, the predominant pathways by which VacJ mutants affect C3 deposition and activate the complement system may be examined. Since deletion of BPSL3147 affects the outer membrane stability (Chapter 4), future work could involve examination of the outer membrane characteristics of the mutant strains, such as surface hydrophobicity (through the measurement of the rate of uptake of membrane permeant 1-*N*-phenyl-naphthylamine (NPN)), and comparison of amounts of surface phospholipids.

To date, I was unable to ascribe the *in vivo* attenuation of the *B. pseudomallei* VacJ mutant to a defect in intracellular replication or survival in murine macrophages. As I did not observe any defects in the early stages of mouse infection studies and *in vitro* infection, it is likely that the *B. pseudomallei* BPSL3147 mutant display similar virulence properties as compared to the wild type during initial phases of infection. Since *bps/3147* encodes a protein that is found in the proteome of the outer membrane (Schell et al., 2011), depletion of the protein may lead to outer membrane defects such as exposure of hidden immunogens. This could have a consequential effect on the elicitation of host immune responses. For example, as the intracellular *B. pseudomallei* escapes into the cytosol, antigenic *B. pseudomallei* proteins present could be processed by the proteasome in the endogenous pathway and presented to CD8+ T cells by class I major histocompatibility complex (MHC), inducing T cell mediated



immunity (Haque et al., 2006). Future work may involve the investigation of immunological correlates during infection of macrophages. It may be useful to infect pre-activated macrophages with the *B. pseudomallei* K96243 BPSL3147 mutant to investigate the role of VacJ in bacterial survival and other intracellular events such as multinucleated cell formation.

Although no sterilizing immunity was achieved, this work has shown that the *B. pseudomallei* K96243 BPSL3147 mutant is a potential live attenuated vaccine candidate, which provides significant protection against a pulmonary infection. Future studies could focus on defining the correlates of protective immunity conferred by vaccination with the *B. pseudomallei* VacJ mutant. Also, since the reversion of an attenuated strain to a wild type strain in the environment may be a major concern for using live attenuated bacteria as vaccines, two or more independent site-specific knockouts could be considered (Choh et al., 2013).

In conclusion, I have shown that VacJ is a novel factor that contributes to serum resistance of *B. pseudomallei* and *B. thailandensis*, independent of the LPS. This study represents a follow up on the STM screen for *in vivo* virulence and confirmed the lipoprotein VacJ as a virulence determinant in *B. pseudomallei* and *B. thailandensis*. Lastly, I have shown that the *B. pseudomallei* BPSL3147 mutant is a potential live attenuated vaccine candidate that confers protection against pulmonary melioidosis.

## Chapter 7 - Bibliography

- AHMAD, N., HASHIM, R. & MOHD NOOR, A. 2013. The in vitro antibiotic susceptibility of Malaysian isolates of *Burkholderia pseudomallei*. *International Journal of Microbiology*, 2013, 7.
- ALEXANDER, A. D., HUXSOLL, D. L., WARNER, A. R., JR, SHEPLER, V. & DORSEY, A. 1970. Serological diagnosis of human melioidosis with indirect hemagglutination and complement fixation tests. *Applied Microbiology*, 20, 825-833.
- ALEXANDER, C. & RIETSCHER, E. T. 2001. Bacterial lipopolysaccharides and innate immunity. *Journal of Endotoxin Research*, 7, 167-202.
- ALLWOOD, E. M., DEVENISH, R. J., PRESCOTT, M., ADLER, B. & BOYCE, J. D. 2011. Strategies for intracellular survival of *Burkholderia pseudomallei*. *Frontiers in Microbiology*, 2, 170.
- ALLWOOD, E. M., LOGUE, C.-A., HAFNER, G. J., KETHEESAN, N., NORTON, R. E., PEAK, I. R. & BEACHAM, I. R. 2008. Evaluation of recombinant antigens for diagnosis of melioidosis. *FEMS Immunology and Medical Microbiology*, 54, 144-153.
- ANTONY, B., PINTO, H., DIAS, M., SHETTY, A. K., SCARIA, B., KURUVILLA, T. & BOLOOR, R. 2010. Spectrum of melioidosis in the suburbs of Mangalore, S West Coast of India. *The Southeast Asian Journal of Tropical Medicine and Public Health*, 41, 169-174.
- ANUNTAGOOL, N., INTACHOTE, P., WUTHIEKANUN, V., WHITE, N. J. & SIRISINHA, S. 1998. Lipopolysaccharide from nonvirulent Ara+ *Burkholderia pseudomallei* isolates is immunologically indistinguishable from lipopolysaccharide from virulent Ara-clinical isolates. *Clinical and Diagnostic Laboratory Immunology*, 5, 225-229.
- ANUNTAGOOL, N., NAIGOWIT, P., PETKANCHANAPONG, V., ARAMSRI, P., PANICHAKUL, T. & SIRISINHA, S. 2000. Monoclonal antibody-based rapid identification of *Burkholderia pseudomallei* in blood culture fluid from patients with community-acquired septicaemia. *Journal of Medical Microbiology*, 49, 1075-1078.
- ANUNTAGOOL, N., WUTHIEKANUN, V., WHITE, N. J., CURRIE, B. J., SERMSWAN, R. W., WONGRATANACHEEWIN, S., TAWEECHASUPAPONG, S., CHAIYAROJ, S. C. & SIRISINHA, S. 2006. Lipopolysaccharide heterogeneity among *Burkholderia pseudomallei* from different geographic and clinical origins. *The American Journal of Tropical Medicine and Hygiene*, 74, 348-352.
- APPASSAKIJ, H., SILPAPOJAKUL, K. R., WANSIT, R. & PORNPATKUL, M. 1990. Diagnostic value of the indirect hemagglutination test for melioidosis in an endemic area. *The American Journal of Tropical Medicine and Hygiene*, 42, 248-253.
- ARIFUZZAMAN, M., MAEDA, M., ITOH, A., NISHIKATA, K., TAKITA, C., SAITO, R., ARA, T., NAKAHIGASHI, K., HUANG, H.-C., HIRAI, A., TSUZUKI, K., NAKAMURA, S., ALTA-UL-AMIN, M., OSHIMA, T., BABA, T., YAMAMOTO, N., KAWAMURA, T., IOKA-NAKAMICHI, T., KITAGAWA, M., TOMITA, M., KANAYA, S., WADA, C. & MORI, H. 2006. Large-scale identification of protein-protein interaction of *Escherichia coli* K-12. *Genome Research*, 16, 686-691.
- ARJCHAROEN, S., WIKRAIPHAT, C., PUDLA, M., LIMPOSUWAN, K., WOODS, D. E., SIRISINHA, S. & UTAISINCHAROEN, P. 2007. Fate of a *Burkholderia pseudomallei* lipopolysaccharide mutant in the mouse macrophage cell line RAW 264.7: possible role for the O-antigenic polysaccharide moiety of lipopolysaccharide in internalization and intracellular survival. *Infection and Immunity*, 75, 4298-4304.
- ASHDOWN, L. R. 1979. An improved screening technique for isolation of *Pseudomonas pseudomallei* from clinical specimens. *Pathology*, 11, 293-297.
- ASHDOWN, L. R. & GUARD, R. W. 1984. The prevalence of human melioidosis in Northern Queensland. *The American Journal of Tropical Medicine and Hygiene*, 33, 474-478.

- ASHDOWN, L. R., JOHNSON, R. W., KOEHLER, J. M. & COONEY, C. A. 1989. Enzyme-linked immunosorbent assay for the diagnosis of clinical and subclinical melioidosis. *Journal of Infectious Diseases*, 160, 253-260.
- ATKINS, T. P., PRIOR, R., MACK, K., RUSSELL, P., NELSON, M., PRIOR, J., ELLIS, J., OYSTON, P. C. F., DOUGAN, G. & TITBALL, R. W. 2002a. Characterisation of an acapsular mutant of *Burkholderia pseudomallei* identified by signature tagged mutagenesis. *Journal of medical microbiology*, 51, 539-547.
- ATKINS, T. P., PRIOR, R. G., MACK, K., RUSSELL, P., NELSON, M., OYSTON, P. C. F., DOUGAN, G. & TITBALL, R. W. 2002b. A mutant of *Burkholderia pseudomallei*, auxotrophic in the branched chain amino acid biosynthetic pathway, is attenuated and protective in a murine model of melioidosis. *Infection and Immunity*, 70, 5290-5294.
- ATTREE, O. & ATTREE, I. 2001. A second type III secretion system in *Burkholderia pseudomallei*: who is the real culprit? *Microbiology*, 147, 3197-3199.
- BABU, M. M., PRIYA, L. M., SELVAN, T. A., MADERA, M., GOUGH, J., ARAVIND, L. & SANKARAN, K. 2006. A database of bacterial lipoproteins (DOLOP) with functional assignments to predicted lipoproteins. *Journal of bacteriology*, 188, 2761-2773.
- BALDER, R., LIPSKI, S., LAZARUS, J. J., GROSE, W., WOOTEN, R. W., HOGAN, R. J., WOODS, D. E. & LAFONTAINE, E. R. 2010. Identification of *Burkholderia mallei* and *Burkholderia pseudomallei* adhesins for human respiratory epithelial cells. *BMC Microbiology*, 10, 250.
- BAUGH, L., GALLAGHER, L. A., PATRAPUVICH, R., CLIFTON, M. C., GARDBERG, A. S., EDWARDS, T. E., ARMOUR, B., BEGLEY, D. W., DIETERICH, S. H., DRANOW, D. M., ABENDROTH, J., FAIRMAN, J. W., FOX, D., 3RD, STAKER, B. L., PHAN, I., GILLESPIE, A., CHOI, R., NAKAZAWA-HEWITT, S., NGUYEN, M. T., NAPULI, A., BARRETT, L., BUCHKO, G. W., STACY, R., MYLER, P. J., STEWART, L. J., MANOIL, C. & VAN VOORHIS, W. C. 2013. Combining functional and structural genomics to sample the essential *Burkholderia* structome. *PLoS One*, 8, e53851.
- BLOM, A. M., HALLSTRÖM, T. & RIESBECK, K. 2009. Complement evasion strategies of pathogens-Acquisition of inhibitors and beyond. *Molecular Immunology*, 46, 2808-2817.
- BODDEY, J. A., FLEGG, C. P., DAY, C. J., BEACHAM, I. R. & PEAK, I. R. 2006. Temperature-regulated microcolony formation by *Burkholderia pseudomallei* requires *pilA* and enhances association with cultured human cells. *Infection and Immunity*, 74, 5374-81.
- BORGHENINI, G., POUBEAU, P., PAGANIN, F., PICOT, S., MICHAULT, A., THIBAUT, F. & BEROD, C. A. 2006. Melioidosis: an imported case from Madagascar. *Journal of Travel Medicine*, 13, 318-320.
- BOS, M. P., ROBERT, V. & TOMMASSEN, J. 2007. Biogenesis of the Gram-negative bacterial outer membrane. *Annual Review of Microbiology*, 61, 191-214.
- BOYCE, J. & ADLER, B. 2000. The capsule is a virulence determinant in the pathogenesis of *Pasteurella multocida* M1404 (B:2). *Infection and Immunity*, 68, 3463-8.
- BRETT, P. J., DESHAZER, D. & WOODS, D. E. 1997. Characterization of *Burkholderia pseudomallei* and *Burkholderia pseudomallei*-like strains. *Epidemiology and Infection*, 118, 137-148.
- BRETT, P. J., DESHAZER, D. & WOODS, D. E. 1998. *Burkholderia thailandensis* sp. nov., a *Burkholderia pseudomallei*-like species. *International Journal of Systematic Bacteriology*, 48, 317-320.
- BROOK, M. D., CURRIE, B. J. & DESMARCHELIER, P. M. 1997. Isolation and identification of *Burkholderia pseudomallei* from soil using selective culture techniques and the polymerase chain reaction. *Journal of Applied Microbiology*, 82, 589-596.

- BROWN, N. F., LEW, A. E. & BEACHAM, I. R. 2000. Identification of new transposable genetic elements in *Burkholderia pseudomallei* using subtractive hybridisation. *FEMS Microbiology Letters*, 183, 73-79.
- BURTINICK, M. N., BRETT, P. J., HARDING, S. V., NGUGI, S. A., RIBOT, W. J., CHANTRATITA, N., SCORPIO, A., MILNE, T. S., DEAN, R. E., FRITZ, D. L., PEACOCK, S. J., PRIOR, J. L., ATKINS, T. P. & DESHAZER, D. 2011. The cluster 1 type VI secretion system is a major virulence determinant in *Burkholderia pseudomallei*. *Infection and Immunity*, 79, 1512-25.
- BURTINICK, M. N. & WOODS, D. E. 1999. Isolation of polymyxin B-susceptible mutants of *Burkholderia pseudomallei* and molecular characterization of genetic loci involved in polymyxin B resistance. *Antimicrobial agents and chemotherapy*, 43, 2648-56.
- CABISCOL, E., TAMARIT, J. & ROS, J. 2000. Oxidative stress in bacteria and protein damage by reactive oxygen species. *International Microbiology*, 3, 3-8.
- CAROFF, M. & KARIBIAN, D. 2003. Structure of bacterial lipopolysaccharides. *Carbohydrate Research*, 338, 2431-2447.
- CARPENTER, C. D., COOLEY, B. J., NEEDHAM, B. D., FISHER, C. R., TRENT, M. S., GORDON, V. & PAYNE, S. M. 2014. The Vps/VacJ (Mla) ABC transporter is required for intercellular spread of *Shigella flexneri*. *Infection and Immunity*, 82, 660-9.
- CASALI, N. & RILEY, L. W. 2007. A phylogenomic analysis of the *Actinomycetales mce* operons. *BMC genomics*, 8, 60.
- CHAN, Y. Y. & CHUA, K. L. 2005. The *Burkholderia pseudomallei* BpeAB-OprB efflux pump : expression and impact on quorum sensing and virulence. *Journal of Bacteriology*, 187, 4707-4719.
- CHANDLER, J. R., DUERKOP, B. A., HINZ, A., WEST, T. E., HERMAN, J. P., CHURCHILL, M. E. A., SKERRETT, S. J. & GREENBERG, E. P. 2009. Mutational analysis of *Burkholderia thailandensis* quorum sensing and self-aggregation. *Journal of Bacteriology*, 191, 5901-5909.
- CHANTRATITA, N., TANDHAVANANT, S., MYERS, N. D., SEAL, S., ARAYAWICHANONT, A., KLIANGSA-AD, A., HITTLE, L. E., ERNST, R. K., EMOND, M. J., WURFEL, M. M., DAY, N. P. J., PEACOCK, S. J. & WEST, T. E. 2013. Survey of innate immune responses to *Burkholderia pseudomallei* in human blood identifies a central role for lipopolysaccharide. *PLoS One*, 8, e81617.
- CHANTRATITA, N., WUTHIEKANUN, V., BOONBUMRUNG, K., TIYAWISUTSRI, R., VESARATCHAVEST, M., LIMMATHUROTSAKUL, D., CHIERAKUL, W., WONGRATANACHEEWIN, S., PUKRITIYAKAMEE, S., WHITE, N. J., DAY, N. P. J. & PEACOCK, S. J. 2007a. Biological relevance of colony morphology and phenotypic switching by *Burkholderia pseudomallei*. *Journal of Bacteriology*, 189, 807-17.
- CHANTRATITA, N., WUTHIEKANUN, V., THANWISAI, A., LIMMATHUROTSAKUL, D., CHENG, A. C., CHIERAKUL, W., DAY, N. P. J. & PEACOCK, S. J. 2007b. Accuracy of enzyme-linked immunosorbent assay using crude and purified antigens for serodiagnosis of melioidosis. *Clinical and Vaccine Immunology*, 14, 110-113.
- CHAOWAGUL, W., WHITE, N. J., DANCE, D. A. B., WATTANAGOON, Y., NAIGOWIT, P., DAVIS, T. M. E., LOOAREESUWAN, S. & PITAKWATCHARA, N. 1989. Melioidosis: a major cause of community-acquired septicemia in northeastern Thailand. *Journal of Infectious Diseases*, 159, 890-899.
- CHEN, Y.-S., LIN, H.-H., MU, J.-J., CHIANG, C.-S., CHEN, C.-H., BUU, L.-M., LIN, Y. E. & CHEN, Y.-L. 2010. Distribution of melioidosis cases and viable *Burkholderia pseudomallei* in soil: evidence for emerging melioidosis in Taiwan. *Journal of clinical microbiology*, 48, 1432-4.

- CHEN, Y., WONG, J., SUN, G. W., LIU, Y., TAN, G.-Y. G. & GAN, Y.-H. 2011. Regulation of type VI secretion system during *Burkholderia pseudomallei* infection. *Infection and Immunity*, 79, 3064-3073.
- CHEN, Y. S., CHEN, S. C., KAO, C. M. & CHEN, Y. L. 2003a. Effects of soil pH, temperature and water content on the growth of *Burkholderia pseudomallei*. *Folia Microbiologica*, 48, 253-6.
- CHEN, Y. S., SHIUAN, D., CHEN, S. C., CHYE, S. M. & CHEN, Y. L. 2003b. Recombinant truncated flagellin of *Burkholderia pseudomallei* as a molecular probe for diagnosis of melioidosis. *Clinical and Diagnostic Laboratory Immunology*, 10, 423-425.
- CHENG, A. & CURRIE, B. 2005a. Melioidosis: epidemiology, pathophysiology, and management. *Clin Microbiol Rev*, 18, 383 - 416.
- CHENG, A. C. & CURRIE, B. J. 2005b. Melioidosis : Epidemiology , Pathophysiology , and Management. *Clinical Microbiology Reviews*, 18, 383-416.
- CHENG, A. C., JACUPS, S. P., GAL, D., MAYO, M. & CURRIE, B. J. 2006. Extreme weather events and environmental contamination are associated with case-clusters of melioidosis in the Northern Territory of Australia. *International Journal of Epidemiology*, 35, 323 - 329.
- CHENG, A. C., JACUPS, S. P., WARD, L. & CURRIE, B. J. 2008a. Melioidosis and Aboriginal seasons in northern Australia. *Transactions of the Royal Society of Tropical Medicine and Hygiene*, 102, S26-9.
- CHENG, A. C., WUTHIEKANUN, V., LIMMATHUROTSAKUL, D., CHIERAKUL, W. & PEACOCK, S. J. 2008b. Intensity of exposure and incidence of melioidosis in Thai children. *Transactions of the Royal Society of Tropical Medicine and Hygiene*, 102, S37-S39.
- CHIANG, S. L., MEKALANOS, J. J. & HOLDEN, D. W. 1999. *In vivo* genetic analysis of bacterial virulence. *Annual Review of Microbiology*, 53, 129-154.
- CHIERAKUL, W., WINOTHAI, W., WATTANAWAITUNECHAI, C., WUTHIEKANUN, V., RUGTAENGAN, T., RATTANALERTNAVEE, J., JITPRATOOM, P., CHAOWAGUL, W., SINGHASIVANON, P., WHITE, N. J., DAY, N. P. J. & PEACOCK, S. J. 2005. Melioidosis in 6 tsunami survivors in southern Thailand. *Clinical Infectious Diseases*, 41, 982-990.
- CHOH, L.-C., ONG, G.-H., VELLASAMY, K. M., KALAISELVAM, K., KANG, W.-T., AL-MALEKI, A. R., MARIAPPAN, V. & VADIVELU, J. 2013. *Burkholderia* vaccines: are we moving forward? *Frontiers in Cellular and Infection Microbiology [electronic resource]*, 3, 5.
- CHOI, K. H., KUMAR, A. & SCHWEIZER, H. P. 2006. A 10-min method for preparation of highly electrocompetent *Pseudomonas aeruginosa* cells: application for DNA fragment transfer between chromosomes and plasmid transformation. *Journal of Microbiological Methods*, 64, 391-7.
- CHOI, K. H., MIMA, T., CASART, Y., RHOLL, D., KUMAR, A., BEACHAM, I. R. & SCHWEIZER, H. P. 2008. Genetic tools for select-agent-compliant manipulation of *Burkholderia pseudomallei*. *Applied and environmental microbiology*, 74, 1064-75.
- CHUA, K. L., CHAN, Y. Y. & GAN, Y. H. 2003. Flagella are virulence determinants of *Burkholderia pseudomallei*. *Infection and Immunity*, 71, 1622-1629.
- COBURN , B., SEKIROV, I. & FINLAY, B. B. 2007. Type III secretion systems and disease. *Clinical Microbiology Reviews*, 20, 535-549.
- COENYE, T., VANDAMME, P., LIPUMA, J. J., GOVAN, J. R. W. & MAHENTHIRALINGAM, E. 2003. Updated version of the *Burkholderia cepacia* complex experimental strain panel. *Journal of Clinical Microbiology*, 41, 2797-2798.
- COMPANT, S., NOWAK, J., COENYE, T., CLÉMENT, C. & AIT BARKA, E. 2008. Diversity and occurrence of *Burkholderia* spp. in the natural environment. *FEMS Microbiology Reviews*, 32, 607-626.

- COREA, E., THEVANESAM, V., PERERA, S., JAYASINGHE, I., EKANAYAKE, A., MASAKORALA, J. & INGLIS, T. J. J. 2012. Melioidosis in Sri Lanka: an emerging infection. *Sri Lankan Journal of Infectious Diseases*, 2, 2-8.
- COULTHURST, S. J. 2013. The type VI secretion system – a widespread and versatile cell targeting system. *Research in Microbiology*, 164, 640-654.
- CRAIG, L., PIQUE, M. E. & TAINER, J. A. 2004. Type IV pilus structure and bacterial pathogenicity. *Nature Reviews: Microbiology*, 2, 363-378.
- CUCCUI, J., EASTON, A., CHU, K. K., BANCROFT, G. J., OYSTON, P. C. F., TITBALL, R. W. & WREN, B. W. 2007. Development of signature-tagged mutagenesis in *Burkholderia pseudomallei* to identify genes important in survival and pathogenesis. *Infection and Immunity*, 75, 1186-95.
- CUCCUI, J., MILNE, T. S., HARMER, N., GEORGE, A. J., HARDING, S. V., DEAN, R. E., SCOTT, A. E., SARKAR-TYSON, M., WREN, B. W., TITBALL, R. W. & PRIOR, J. L. 2012. Characterization of the *Burkholderia pseudomallei* K96243 capsular polysaccharide I coding region. *Infection and Immunity*, 80, 1209-1221.
- CULLINANE, M., GONG, L., LI, X., ADLER, N.-L., TRA, T., WOLVETANG, E., PRESCOTT, M., BOYCE, J. D., DEVENISH, R. J. & ADLER, B. 2008. Stimulation of autophagy suppresses the intracellular survival of *Burkholderia pseudomallei* in mammalian cell lines. *Autophagy*, 4, 744-753.
- CURRIE, B. J., DANCE, D. A. B. & CHENG, A. C. 2008. The global distribution of *Burkholderia pseudomallei* and melioidosis: an update. *Transactions of the Royal Society of Tropical Medicine and Hygiene*, 102, S1-4.
- CURRIE, B. J., FISHER, D. A., ANSTEY, N. M. & JACUPS, S. P. 2000a. Melioidosis: acute and chronic disease, relapse and re-activation. *Transactions of the Royal Society of Tropical Medicine and Hygiene*, 94, 301-304.
- CURRIE, B. J., FISHER, D. A., HOWARD, D. M., BURROW, J. N. C., LO, D., SELVA-NAYAGAM, S., ANSTEY, N. M., HUFFAM, S. E., SNELLING, P. L., MARKS, P. J., STEPHENS, D. P., LUM, G. D., JACUPS, S. P. & KRAUSE, V. L. 2000b. Endemic melioidosis in tropical northern Australia: a 10-Year prospective study and review of the literature. *Clinical Infectious Diseases*, 31, 981-986.
- CURRIE, B. J. & JACUPS, S. P. 2003. Intensity of rainfall and severity of melioidosis, Australia. *Emerging Infectious Diseases*, 9, 1538-42.
- CURRIE, B. J., JACUPS, S. P., CHENG, A. C., FISHER, D. A., ANSTEY, N. M., HUFFAM, S. E. & KRAUSE, V. L. 2004. Melioidosis epidemiology and risk factors from a prospective whole-population study in northern Australia. *Tropical Medicine & International Health*, 9, 1167-1174.
- CURRIE, B. J., WARD, L. & CHENG, A. C. 2010. The epidemiology and clinical spectrum of melioidosis: 540 cases from the 20 year Darwin prospective study. *PLoS Neglected Tropical Diseases*, 4, e900.
- D'CRUZE, T., GONG, L., TREERAT, P., RAMM, G., BOYCE, J., PRESCOTT, M., ADLER, B. & DEVENISH, R. J. 2011. A role for the *Burkholderia pseudomallei* type three secretion system cluster 1 *bpscN* gene in virulence. *Infection and Immunity*, 79, 3659-64.
- DANCE, D. A. B. 2000. Melioidosis as an emerging global problem. *Acta tropica*, 74, 115-119.
- DERIS, Z. Z., AKTER, J., SIVANESAN, S., ROBERTS, K. D., THOMPSON, P. E., NATION, R. L., LI, J. & VELKOV, T. 2014. A secondary mode of action of polymyxins against Gram-negative bacteria involves the inhibition of NADH-quinone oxidoreductase activity. *Journal of Antibiotics*, 67, 147-151.
- DESHAZER, D. 2007. Virulence of clinical and environmental isolates of *Burkholderia oklahomensis* and *Burkholderia thailandensis* in hamsters and mice. *FEMS Microbiology Letters*, 277, 64-69.

- DESHAZER, D., BRETT, P. J., CARLYON, R. & WOODS, D. E. 1997. Mutagenesis of *Burkholderia pseudomallei* with Tn5-OT182: Isolation of motility mutants and molecular characterization of the flagellin structural gene. *Journal of Bacteriology* 179, 2116-25.
- DESHAZER, D., BRETT, P. J. & WOODS, D. E. 1998. The type II O-antigenic polysaccharide moiety of *Burkholderia pseudomallei* lipopolysaccharide is required for serum resistance and virulence. *Molecular microbiology*, 30, 1081-100.
- DESHAZER, D., WAAG, D. M., FRITZ, D. L. & WOODS, D. E. 2001. Identification of a *Burkholderia mallei* polysaccharide gene cluster by subtractive hybridization and demonstration that the encoded capsule is an essential virulence determinant. *Microbial Pathogenesis*, 30, 253-269.
- DHARAKUL, T., TASSANEETRITHEP, B., TRAKULSOMBOON, S. & SONGSIVILAI, S. 1999. Phylogenetic analysis of Ara+ and Ara- *Burkholderia pseudomallei* isolates and development of a multiplex PCR procedure for rapid discrimination between the two biotypes. *Journal of Clinical Microbiology*, 37, 1906-1912.
- DRAMSI, S., MAGNET, S., DAVISON, S. & ARTHUR, M. 2008. Covalent attachment of proteins to peptidoglycan. *FEMS Microbiology Reviews*, 32, 307-320.
- DRUAR, C., YU, F., BARNES, J. L., OKINAKA, R. T., CHANTRATITA, N., BEG, S., STRATILO, C. W., OLIVE, A. J., SOLTES, G., RUSSELL, M. L., LIMMATHUROTSAKUL, D., NORTON, R. E., NI, S. X., PICKING, W. D., JACKSON, P. J., STEWART, D. I. H., TSVETNITSKY, V., PICKING, W. L., CHERWONOGRODZKY, J. W., KETHEESAN, N., PEACOCK, S. J. & WIERSMA, E. J. 2008. Evaluating *Burkholderia pseudomallei* Bip proteins as vaccines and Bip antibodies as detection agents. *FEMS Immunology & Medical Microbiology*, 52, 78-87.
- EBERL, L. 2006. Quorum sensing in the genus *Burkholderia*. *International journal of medical microbiology*, 296, 103-10.
- ECKERT, S. E., DZIVA, F., CHAUDHURI, R. R., LANGRIDGE, G. C., TURNER, D. J., PICKARD, D. J., MASKELL, D. J., THOMSON, N. R. & STEVENS, M. P. 2011. Retrospective application of transposon-directed insertion site sequencing to a library of signature-tagged mini-Tn5Km2 mutants of *Escherichia coli* O157:H7 screened in cattle. *Journal of Bacteriology* 193, 1771-6.
- EDELMAN, R., PALMER, K., RUSS, K. G., SECREST, H. P., BECKER, J. A., BODISON, S. A., PERRY, J. G., SILLIS, A. R., BARBOUR, A. G., LUKE, C. J., HANSON, M. S., STOVER, C. K., BURLEIN, J. E., BANSAL, G. P., CONNOR, E. M. & KOENIG, S. 1999. Safety and immunogenicity of recombinant Bacille Calmette-Guérin (rBCG) expressing *Borrelia burgdorferi* outer surface protein A (OspA) lipoprotein in adult volunteers: a candidate Lyme disease vaccine. *Vaccine*, 17, 904-14.
- EGAN, A. M. & GORDON, D. L. 1996. *Burkholderia pseudomallei* activates complement and is ingested but not killed by polymorphonuclear leukocytes. *Infection and Immunity*, 64, 4952-9.
- ESSEX-LOPRESTI, A. E., BODDEY, J. A., THOMAS, R., SMITH, M. P., HARTLEY, M. G., ATKINS, T. P., BROWN, N. F., TSANG, C. H., PEAK, I. R. A., HILL, J., BEACHAM, I. R. & TITBALL, R. W. 2005. A type IV pilin, PilA, contributes to adherence of *Burkholderia pseudomallei* and virulence *in vivo*. *Infection and Immunity*, 73, 1260-1264.
- ESTRADA-DE LOS SANTOS, P., VINUESA, P., MARTÍNEZ-AGUILAR, L., HIRSCH, A. M. & CABALLERO-MELLADO, J. 2013. Phylogenetic analysis of *Burkholderia* species by multilocus sequence analysis. *Current Microbiology*, 67, 51-60.
- FEINGOLD, D. S., GOLDMAN, J. N. & KURITZ, H. M. 1968. Locus of the action of serum and the role of lysozyme in the serum bactericidal reaction. *J Bacteriol*, 96, 2118-26.

- FELGNER, P. L., KAYALA, M. A., VIGIL, A., BURK, C., NAKAJIMA-SASAKI, R., PABLO, J., MOLINA, D. M., HIRST, S., CHEW, J. S. W., WANG, D., TAN, G., DUFFIELD, M., YANG, R., NEEL, J., CHANTRATITA, N., BANCROFT, G., LERTMEMONGKOLCHAI, G., DAVIES, D. H., BALDI, P., PEACOCK, S. J. & TITBALL, R. W. 2009. A *Burkholderia pseudomallei* protein microarray reveals serodiagnostic and cross-reactive antigens. *Proceedings of the National Academy of Sciences of the United States of America*, 106, 13499-13504.
- FERRIÈRES, L., GAËLLE, H., NHAM, T., GUÉROUT, A.-M., MAZEL, D., BELOIN, C. & GHIGO, J.-M. 2010. Silent mischief: bacteriophage Mu insertions contaminate products of *Escherichia coli* random mutagenesis performed using suicidal transposon delivery plasmids mobilized by broad-host-range RP4 conjugative machinery. *Journal of Bacteriology*, 192, 6418-27.
- FRANK, M. M., JOINER, K. & HAMMER, C. 1987. The function of antibody and complement in the lysis of bacteria. *Reviews of Infectious Diseases*, 9, S537-S545.
- FRENCH, C. T., TOESCA, I. J., WU, T.-H., TESLAA, T., BEATY, S. M., WONG, W., LIU, M., SCHRÖDER, I., CHIOU, P.-Y., TEITELL, M. A. & MILLER, J. F. 2011. Dissection of the *Burkholderia* intracellular life cycle using a photothermal nanoblade. *Proceedings of the National Academy of Sciences of the United States of America*, 108, 12095-100.
- GAL, D., MAYO, M., SPENCER, E., CHENG, A. C. & CURRIE, B. J. 2005. Application of a polymerase chain reaction to detect *Burkholderia pseudomallei* in clinical specimens from patients with suspected melioidosis. *American Journal of Tropical Medicine and Hygiene*, 73, 1162-1164.
- GALYOV, E. E., BRETT, P. J. & DESHAZER, D. 2010. Molecular insights into *Burkholderia pseudomallei* and *Burkholderia mallei* pathogenesis. *Annual review of microbiology*, 64, 495-517.
- GAN, Y. H., WEST, T. E. & SIRISINHA, S. 2012. Initiation of *Burkholderia pseudomallei* infection. In: KETHEESAN, N. (ed.) *Melioidosis - A century of observation and research*. Elsevier B.V.
- GARRITY, G. M. (ed.) 2005. *Bergey's manual of systematic bacteriology*, New York: Springer-Verlag.
- GAY, P., LE COQ, D., STEINMETZ, M., FERRARI, E. & HOCH, J. A. 1983. Cloning structural gene *sacB*, which encodes for exoenzyme levansucrase of *Bacillus subtilis*: expression of the gene in *Escherichia coli*. *Journal of Bacteriology* 153, 1424-31.
- GHOSH, P. 2004. Process of protein transport by the type III secretion system. *Microbiology and Molecular Biology Reviews*, 68, 771-795.
- GILMORE, G., BARNES, J., KETHEESAN, N. & NORTON, R. 2007. Use of antigens derived from *Burkholderia pseudomallei*, *B. thailandensis*, and *B. cepacia* in the indirect hemagglutination assay for melioidosis. *Clinical and vaccine immunology*, 14, 1529-31.
- GLASS, M. B., GEE, J. E., STEIGERWALT, A. G., CAVUOTI, D., BARTON, T., HARDY, R. D., GODOY, D., SPRATT, B. G., CLARK, T. A. & WILKINS, P. P. 2006. Pneumonia and septicemia caused by *Burkholderia thailandensis* in the United States. *Journal of Clinical Microbiology*, 44, 4601-4.
- GLASS, M. B. & WALSH, A. L. 2012. Isolation and identification of *Burkholderia pseudomallei* in clinical samples. In: KETHEESAN, N. (ed.) *Melioidosis - A century of observation and research*. Elsevier B.V.
- GODOY, D., RANDLE, G., SIMPSON, A. J., AANENSEN, D. M., PITT, T. L., KINOSHITA, R. & SPRATT, B. G. 2003. Multilocus sequence typing and evolutionary relationships among the causative agents of melioidosis and glanders, *Burkholderia pseudomallei* and *Burkholderia mallei*. *Journal of Clinical Microbiology*, 41, 2068 - 2079.



- GONG, L., CULLINANE, M., TREERAT, P., RAMM, G., PRESCOTT, M., ADLER, B., BOYCE, J. D. & DEVENISH, R. J. 2011. The *Burkholderia pseudomallei* type III secretion system and BopA are required for evasion of LC3-associated phagocytosis. *PLoS One*, 6, e17852.
- GRODE, L., KURSAR, M., FENSTERLE, J., KAUFMANN, S. H. E. & HESS, J. 2002. Cell-mediated immunity induced by recombinant *Mycobacterium bovis* Bacille Calmette-Guérin strains against an intracellular bacterial pathogen: importance of antigen secretion or membrane-targeted antigen display as lipoprotein for vaccine efficacy. *Journal of Immunology* 168, 1869-76.
- GUPTA, S. D., GAN, K., SCHMID, M. B. & WU, H. C. 1993. Characterization of a temperature-sensitive mutant of *Salmonella typhimurium* defective in apolipoprotein N-acyltransferase. *Journal of Biological Chemistry*, 268, 16551-16556.
- HAASE, A., BRENNAN, M., BARRETT, S., WOOD, Y., HUFFAM, S., O'BRIEN, D. & CURRIE, B. 1998. Evaluation of PCR for diagnosis of melioidosis. *Journal of Clinical Microbiology*, 36, 1039-41.
- HAN, S., JUNGHYUN, H., JAEHEE, M., HYOSEOK, S., HYOJEONG, Y., HEE-SUN, S., BONG-SU, K., WILLIAM, C. N. & HEENAM STANLEY, K. 2009. Simple sequence repeat (SSR)-based gene diversity in *Burkholderia pseudomallei* and *Burkholderia mallei*. *Molecules and Cells*, 27, 237-241.
- HANTKE, K. & BRAUN, V. 1973. Covalent binding of lipid to protein. Diglyceride and amide-linked fatty acid at the N-terminal end of the murein-lipoprotein of the *Escherichia coli* outer membrane. *European Journal of Biochemistry*, 34, 284-296.
- HAQUE, A., CHU, K., EASTON, A., STEVENS, M. P., GALYOV, E. E., ATKINS, T. P., TITBALL, R. W. & BANCROFT, G. J. 2006. A live experimental vaccine against *Burkholderia pseudomallei* elicits CD4+ T cell-mediated immunity, priming T cells specific for 2 type III secretion system proteins. *Journal of Infectious Diseases*, 194, 1241-1248.
- HARAGA, A., WEST, T. E., BRITTNACHER, M. J., SKERRETT, S. J. & MILLER, S. I. 2008. *Burkholderia thailandensis* as a model system for the study of the virulence-associated type III secretion system of *Burkholderia pseudomallei*. *Infection and Immunity*, 76, 5402-11.
- HARLEY, V. S., DANCE, D. A. B., DRASAR, B. S. & TOVEY, G. 1998. Effects of *Burkholderia pseudomallei* and other *Burkholderia* species on eukaryotic cells in tissue culture. *Microbios* 96, 71-93.
- HECKMAN, K. L. & PEASE, L. R. 2007. Gene splicing and mutagenesis by PCR-driven overlap extension. *Nature protocols*, 2, 924-32.
- HEEB, S., BLUMER, C. & HAAS, D. 2002. Regulatory RNA as mediator in GacA/RsmA-dependent global control of exoproduct formation in *Pseudomonas fluorescens* CHA0. *Journal of Bacteriology* 184, 1046-1056.
- HELLWAGE, J., MERI, T., HEIKKILÄ, T., ALITALO, A., PANELIUS, J., LAHDENNE, P., SEPPÄLÄ, I. J. T. & MERI, S. 2001. The complement regulator factor H binds to the surface protein OspE of *Borrelia burgdorferi*. *Journal of Biological Chemistry*, 276, 8427-8435.
- HENAO-TAMAYO, M., JUNQUEIRA-KIPNIS, A. P., ORDWAY, D., GONZALES-JUARRERO, M., STEWART, G. R., YOUNG, D. B., WILKINSON, R. J., BASARABA, R. J. & ORME, I. M. 2007. A mutant of *Mycobacterium tuberculosis* lacking the 19-kDa lipoprotein Rv3763 is highly attenuated in vivo but retains potent vaccinogenic properties. *Vaccine*, 25, 7153-7159.
- HENSEL, M., SHEA, J. E., GLEESON, C., JONES, M. D., DALTON, E. & HOLDEN, D. W. 1995. Simultaneous identification of bacterial virulence genes by negative selection. *Science*, 269, 400-403.

- HOLDEN, M. T. G., TITBALL, R. W., PEACOCK, S. J., CERDEÑO-TÁRRAGA, A. M., ATKINS, T. P., CROSSMAN, L. C., PITT, T. L., CHURCHER, C., MUNGALL, K., BENTLEY, S. D., SEBAIHIA, M., THOMSON, N. R., BASON, N., BEACHAM, I. R., BROOKS, K., BROWN, K. A., BROWN, N. F., CHALLIS, G. L., CHEREVACH, I., CHILLINGWORTH, T., CRONIN, A., CROSSETT, B., DAVIS, P., DESHAZER, D., FELTWELL, T., FRASER, A., HANCE, Z., HAUSER, H., HOLROYD, S., JAGELS, K., KEITH, K. E., MADDISON, M., MOULE, S., PRICE, C., QUAIL, M. A., RABBINOWITSCH, E., RUTHERFORD, K., SANDERS, M., SIMMONDS, M., SONGSIVILAI, S., STEVENS, K., TUMAPA, S., VESARATCHAVEST, M., WHITEHEAD, S., YEATS, C., BARRELL, B. G., OYSTON, P. C. F. & PARKHILL, J. 2004. Genomic plasticity of the causative agent of melioidosis, *Burkholderia pseudomallei*. *Proceedings of the National Academy of Sciences of the United States of America*, 101, 14240-5.
- INGLIS, T. J., ROBERTSON, T., WOODS, D. E., DUTTON, N. & CHANG, B. J. 2003. Flagellum-mediated adhesion by *Burkholderia pseudomallei* precedes invasion of *Acanthamoeba astronyxis*. *Infection and Immunity*, 71, 2280-2282.
- INGLIS, T. J. J., RIGBY, P., ROBERTSON, T. A., DUTTON, N. S., HENDERSON, M. & CHANG, B. J. 2000. Interaction between *Burkholderia pseudomallei* and *Acanthamoeba* species results in coiling phagocytosis, endamebic bacterial survival, and escape. *Infection and immunity*, 68, 1681-6.
- INGLIS, T. J. J. & SAGRIPANTI, J.-L. 2006. Environmental factors that affect the survival and persistence of *Burkholderia pseudomallei*. *Applied and Environmental Microbiology*, 72, 6865-75.
- INOUE, S., WANG, S., SEKIZAWA, J., HALEGOUA, S. & INOUE, M. 1977. Amino acid sequence for the peptide extension on the prolipoprotein of the *Escherichia coli* outer membrane. *Proceedings of the National Academy of Sciences of the United States of America*, 74, 1004-8.
- ISMAIL, G., RAZAK, N., MOHAMED, R., EMBI, N. & OMAR, O. 1988. Resistance of *Pseudomonas pseudomallei* to normal human serum bactericidal action. *Microbiology and Immunology*, 32, 645-52.
- JONES, A. L., BEVERIDGE, T. J. & WOODS, D. E. 1996. Intracellular survival of *Burkholderia pseudomallei*. *Infection and immunity*, 64, 782-90.
- JONES, S. M., ELLIS, J. F., RUSSELL, P., GRIFFIN, K. F. & OYSTON, P. C. F. 2002. Passive protection against *Burkholderia pseudomallei* infection in mice by monoclonal antibodies against capsular polysaccharide, lipopolysaccharide or proteins. *Journal of Medical Microbiology*, 51, 1055-1062.
- KANAPHUN, P., THIRAWATTANASUK, N., SUPUTTAMONGKOL, Y., NAIGOWIT, P., DANCE, D. A. B., SMITH, M. D. & WHITE, N. J. 1993. Serology and carriage of *Pseudomonas pseudomallei*: a prospective study in 1000 hospitalized children in northeast Thailand. *Journal of Infectious Diseases*, 167, 230-233.
- KATANGWE, T., PURCELL, J., BAR-ZEEV, N., DENIS, B., MONTGOMERY, J., ALAERTS, M., HEYDERMAN, R. S., DANCE, D. A. B., KENNEDY, N., FEASEY, N. & MOXON, C. A. 2013. Human melioidosis, Malawi 2011. *Emerging Infectious Diseases*, 19, 981-4.
- KAUFMANN, S. H. E. 1993. Immunity to intracellular bacteria. *Annual Review of Immunology*, 11, 129-163.
- KESPICHAYAWATTANA, W., RATTANACHETKUL, S., WANUN, T., UTAISINCHAROEN, P. & SIRISINHA, S. 2000. *Burkholderia pseudomallei* induces cell fusion and actin-associated membrane protrusion: a possible mechanism for cell-to-cell spreading. *Infection and immunity*, 68, 5377-84.

- KHAN, I., WIELER, L. H., MELZER, F., ELSCHNER, M. C., MUHAMMAD, G., ALI, S., SPRAGUE, L. D., NEUBAUER, H. & SAQIB, M. 2013. Glanders in animals: A review on epidemiology, clinical presentation, diagnosis and countermeasures. *Transboundary and Emerging Diseases*, 60, 204-221.
- KIM, H., SCHELL, M., YU, Y., ULRICH, R., SARRIA, S., NIERMAN, W. & DESHAZER, D. 2005a. Bacterial genome adaptation to niches: divergence of the potential virulence genes in three *Burkholderia* species of different survival strategies. *BMC Genomics*, 6, 174.
- KIM, H. S., SCHELL, M., YU, Y., ULRICH, R. L., SARRIA, S. H., NIERMAN, W. & DESHAZER, D. 2005b. Bacterial genome adaptation to niches: Divergence of the potential virulence genes in three *Burkholderia* species of different survival strategies. *BMC Genomics*, 6, 174.
- KOVACS-SIMON, A., TITBALL, R. W. & MICHELL, S. L. 2011. Lipoproteins of bacterial pathogens. *Infection and Immunity*, 79, 548-61.
- KROLL, J. S., MOXON, E. R. & LOYNDS, B. M. 1993. An ancestral mutation enhancing the fitness and increasing the virulence of *Haemophilus influenzae* type b. *Journal of Infectious Diseases*, 168, 172-176.
- KUMAR, A., MAYO, M., TRUNCK, L. A., CHENG, A. C., CURRIE, B. J. & SCHWEIZER, H. P. 2008a. Expression of resistance-nodulation-cell-division efflux pumps in commonly used *Burkholderia pseudomallei* strains and clinical isolates from northern Australia. *Transactions of The Royal Society of Tropical Medicine and Hygiene*, 102, S145-S151.
- KUMAR, G. S. S., RAJ, P. M., CHACKO, G., LALITHA, M. K., CHACKO, A. G. & RAJSHEKHAR, V. 2008b. Cranial melioidosis presenting as a mass lesion or osteomyelitis. *Journal of Neurosurgery*, 108, 243-247.
- KUNAKORN, M., RAKSAKAIT, K., SETHAUDOM, C., SERMSWAN, R. W. & DHARAKUL, T. 2000. Comparison of three PCR primer sets for diagnosis of septicemic melioidosis. *Acta Tropica*, 74, 247-251.
- LANGRIDGE, G. C., PHAN, M.-D., TURNER, D. J., PERKINS, T. T., PARTS, L., HAASE, J., CHARLES, I., MASKELL, D. J., PETERS, S. E., DOUGAN, G., WAIN, J., PARKHILL, J. & TURNER, A. K. 2009. Simultaneous assay of every *Salmonella Typhi* gene using one million transposon mutants. *Genome Research*, 19, 2308-2316.
- LARSEN, E., SMITH, J. J., NORTON, R. & CORKERON, M. 2013. Survival, sublethal injury and recovery of environmental *Burkholderia pseudomallei* in soil subject to desiccation. *Applied and Environmental Microbiology*, 79, 2424-7.
- LAZAR ADLER, N. R., GOVAN, B., CULLINANE, M., HARPER, M., ADLER, B. & BOYCE, J. D. 2009. The molecular and cellular basis of pathogenesis in melioidosis: how does *Burkholderia pseudomallei* cause disease? *FEMS microbiology reviews*, 33, 1079-99.
- LE HELLO, S., CURRIE, B. J., GODOY, D., SPRATT, B. G., MIKULSKI, M., LACASSIN, F. & GARIN, B. 2005. Melioidosis in New Caledonia. *Emerging Infectious Diseases*, 11, 1607-9.
- LEELARASAMEE, A. & BOVORNKITTI, S. 1989. Melioidosis: review and update. *Reviews of Infectious Diseases*, 11, 413-25.
- LEON, C. G., TORY, R., JIA, J., SIVAK, O. & WASAN, K. M. 2008. Discovery and development of toll-like receptor 4 (TLR4) antagonists: a new paradigm for treating sepsis and other diseases. *Pharmaceutical Research*, 25, 1751-1761.
- LERTPATANASUWUN, N., SERMSRI, K., PETKASEAM, A., TRAKULSOMBOON, S., THAMLIKITKUL, V. & SUPUTTAMONGKOL, Y. 1999. Arabinose-positive *Burkholderia pseudomallei* infection in humans : case report. *Clinical Infectious Diseases*, 28, 927-928.
- LEVY, A., MERRITT, A. J., ARAVENA-ROMAN, M., HODGE, M. M. & INGLIS, T. J. J. 2008. Expanded range of *Burkholderia* species in Australia. *The American Journal of Tropical Medicine and Hygiene*, 78, 599-604.

- LEWIS, F. A. & OLDS, R. J. 1952. Melioidosis in sheep and a goat in north Queensland. *Australian Veterinary Journal*, 28, 145-150.
- LIMMATHUROTSAKUL, D., CHAOWAGUL, W., CHERAKUL, W., STEPNIIEWSKA, K., MAHARJAN, B., WUTHIEKANUN, V., WHITE, N. J., DAY, N. P. J. & PEACOCK, S. J. 2006. Risk factors for recurrent melioidosis in northeast Thailand. *Clinical Infectious Diseases*, 43, 979-986.
- LIMMATHUROTSAKUL, D., DANCE, D. A. B., WUTHIEKANUN, V., KAESTLI, M., MAYO, M., WARNER, J., WAGNER, D. M., TUANYOK, A., WERTHEIM, H., YOKE CHENG, T., MUKHOPADHYAY, C., PUTHUCHEARY, S., DAY, N. P. J., STEINMETZ, I., CURRIE, B. J. & PEACOCK, S. J. 2013. Systematic review and consensus guidelines for environmental sampling of *Burkholderia pseudomallei*. *PLoS Neglected Tropical Diseases*, 7, e2105.
- LIMMATHUROTSAKUL, D. & PEACOCK, S. J. 2011. Melioidosis: a clinical overview. *British medical bulletin*, 99, 125-39.
- LIMMATHUROTSAKUL, D., WONGRATANACHEEWIN, S., TEERAWATTANASOOK, N., WONGSUWAN, G., CHAISUKSANT, S., CHETCHOTISAKD, P., CHAOWAGUL, W., DAY, N. P. J. & PEACOCK, S. J. 2010a. Increasing incidence of human melioidosis in northeast Thailand. *The American Journal of Tropical Medicine and Hygiene*, 82, 1113-1117.
- LIMMATHUROTSAKUL, D., WONGSUWAN, G., AANENSEN, D., NGAMWILAI, S., SAIPROM, N., RONGKARD, P., THAI PADUNGPANIT, J., KANOKSIL, M., CHANTRATITA, N., DAY, N. P. J. & PEACOCK, S. J. 2014. Melioidosis caused by *Burkholderia pseudomallei* in drinking water, Thailand, 2012. *Emerging Infectious Diseases*, 20, 265-268.
- LIMMATHUROTSAKUL, D., WUTHIEKANUN, V., CHANTRATITA, N., WONGSUWAN, G., AMORNCHAI, P., DAY, N. P. J. & PEACOCK, S. J. 2010b. *Burkholderia pseudomallei* is spatially distributed in soil in northeast Thailand. *PLoS Neglected Tropical Diseases*, 4, e694.
- LINK, A. J., PHILLIPS, D. & CHURCH, G. M. 1997. Methods for generating precise deletions and insertions in the genome of wild-type *Escherichia coli*: application to open reading frame characterization. *Journal of Bacteriology*, 179, 6228-37.
- LIPSITZ, R., GARGES, S., ROSEMARIE, A., BACCAM, P., BLANEY, D. D., CHENG, A. C., CURRIE, B. J., DANCE, D. A. B., GEE, J. E., LARSEN, J., LIMMATHUROTSAKUL, D., MORROW, M. G., NORTON, R., O'MARA, E., PEACOCK, S. J., PESIK, N., ROGERS, L. P., SCHWEIZER, H. P., STEINMETZ, I., TAN, G.-Y. G., TAN, P., WIERSINGA, J., WUTHIEKANUN, V. & SMITH, T. L. 2012. Workshop on treatment of and postexposure prophylaxis for *Burkholderia pseudomallei* and *B. mallei* infection, 2010. *Emerging Infectious Diseases*, 18, e2.
- LOGUE, C.-A., PEAK, I. R. A. & BEACHAM, I. R. 2009. Facile construction of unmarked deletion mutants in *Burkholderia pseudomallei* using *sacB* counter-selection in sucrose-resistant and sucrose-sensitive isolates. *Journal of Microbiological Methods*, 76, 320-323.
- LORENZO, V. D. E., HERRERO, M., JAKUBZIK, U. & TIMMIS, K. N. 1990. Mini-Tn5 transposon derivatives for insertion mutagenesis, promoter probing, and chromosomal insertion of cloned DNA in Gram-negative eubacteria. *Journal of Bacteriology* 172, 6568-6572.
- LOSADA, L., RONNING, C. M., DESHAZER, D., WOODS, D. E., FEDOROVA, N., STANLEY KIM, H., SHABALINA, S. A., PEARSON, T. R., BRINKAC, L., TAN, P., NANDI, T., CRABTREE, J., BADGER, J., BECKSTROM-STERNBERG, S., SAQIB, M., SCHUTZER, S. E., KEIM, P. & NIERMAN, W. C. 2010. Continuing evolution of *Burkholderia mallei* through genome reduction and large-scale rearrangements. *Genome Biology and Evolution*, 2, 102-116.

- LU, R., POPOV, V., PATEL, J. & EAVES-PYLES, T. 2012. *Burkholderia mallei* and *Burkholderia pseudomallei* stimulate differential inflammatory responses from human alveolar type II cells (ATII) and macrophages. *Frontiers in Cellular and Infection Microbiology [electronic resource]*, 2, 165.
- MADICO, G., WELSCH, J. A., LEWIS, L. A., MCNAUGHTON, A., PERLMAN, D. H., COSTELLO, C. E., NGAMPASUTADOL, J., VOGEL, U., GRANOFF, D. M. & RAM, S. 2006. The meningococcal vaccine candidate GNA1870 binds the complement regulatory protein factor H and enhances serum resistance. *Journal of Immunology*, 177, 501-510.
- MAHARJAN, B., CHANTRATITA, N., VESARATCHAVEST, M., CHENG, A. C., WUTHIEKANUN, V., CHIERAKUL, W., CHAOWAGUL, W., DAY, N. P. J. & PEACOCK, S. J. 2005. Recurrent melioidosis in patients in northeast Thailand is frequently due to reinfection rather than relapse. *Journal of Clinical Microbiology*, 43, 6032-6034.
- MALCZEWSKI, A. B., OMAN, K. M., NORTON, R. E. & KETHEESAN, N. 2005. Clinical presentation of melioidosis in Queensland, Australia. *Transactions of The Royal Society of Tropical Medicine and Hygiene*, 99, 856-860.
- MALINVERNI, J. C. & SILHAVY, T. J. 2009. An ABC transport system that maintains lipid asymmetry in the gram-negative outer membrane. *Proceedings of the National Academy of Sciences of the United States of America*, 106, 8009-14.
- MATSUURA, M. 2013. Structural modifications of bacterial lipopolysaccharide that facilitate Gram-negative bacteria evasion of host innate immunity. *Frontiers in Immunology*, 4, 109.
- MEUMANN, E. M., NOVAK, R. T., GAL, D., KAESTLI, M. E., MAYO, M., HANSON, J. P., SPENCER, E., GLASS, M. B., GEE, J. E., WILKINS, P. P. & CURRIE, B. J. 2006. Clinical evaluation of a type III secretion system real-time PCR assay for diagnosing melioidosis. *Journal of Clinical Microbiology*, 44, 3028-3030.
- MILTON, D. L., O'TOOLE, R., HÖRSTEDT, P. & WOLF-WATZ, H. 1996. Flagellin A is essential for the virulence of *Vibrio anguillarum*. *Journal of Bacteriology*, 178, 1310-9.
- MIMA, T. & SCHWEIZER, H. P. 2010. The BpeAB-OprB efflux pump of *Burkholderia pseudomallei* 1026b does not play a role in quorum sensing, virulence factor production, or extrusion of aminoglycosides but is a broad-spectrum drug efflux system. *Antimicrobial Agents and Chemotherapy*, 54, 3113-3120.
- MONTUFAR, F., ACOSTA, J. O., ORTEGA, H. & FRANCO, L. 2011. Melioidosis in Colombia. An emerging disease. *Chest*, 140, 753A.
- MOORE, R. A., DESHAZER, D., RECKSEIDLER, S. L., WEISSMAN, A. & WOODS, D. E. 1999. Efflux-mediated aminoglycoside and macrolide resistance in *Burkholderia pseudomallei*. *Antimicrobial agents and chemotherapy*, 43, 465-70.
- MOORE, R. A., RECKSEIDLER, S. L., KIM, H., NIERMAN, W., YU, Y., TUANYOK, A., WARAWA, J., DESHAZER, D. & WOODS, D. E. 2004. Contribution of gene loss to the pathogenic evolution of *Burkholderia pseudomallei* and *Burkholderia mallei*. *Infection and Immunity*, 72, 4172-87.
- MOULE, M. G., HEMSLEY, C. M., SEET, Q., GUERRA-ASSUNÇÃO, J. A., LIM, J., SARKAR-TYSON, M., CLARK, T. G., TAN, P. B. O., TITBALL, R. W., CUCCUI, J. & WREN, B. W. 2014. Genome-wide saturation mutagenesis of *Burkholderia pseudomallei* K96243 predicts essential genes and novel targets for antimicrobial development. *mBio [electronic resource]*, 5, e00926-13.
- NAKAMURA, S., SHCHEPETOV, M., DALIA, A. B., CLARK, S. E., MURPHY, T. F., SETHI, S., GILSDORF, J. R., SMITH, A. L. & WEISER, J. N. 2011. Molecular basis of increased serum resistance among pulmonary isolates of non-typeable *Haemophilus influenzae*. *PLoS Pathogens*, 7, e1001247.

- NANDI, T., ONG, C., SINGH, A. P., BODDEY, J., ATKINS, T. P., SARKAR-TYSON, M., ESSEX-LOPRESTI, A. E., CHUA, H. H., PEARSON, T., KREISBERG, J. F., NILSSON, C., ARIYARATNE, P., RONNING, C., LOSADA, L., RUAN, Y., SUNG, W.-K., WOODS, D. E., TITBALL, R. W., BEACHAM, I., PEAK, I. R., KEIM, P., NIERMAN, W. C. & TAN, P. 2010. A genomic survey of positive selection in *Burkholderia pseudomallei* provides insights into the evolution of accidental virulence. *PLoS Pathogens*, 6, e1000845.
- NANDI, T. & TAN, P. 2012. The *Burkholderia pseudomallei* genome - an emerging model for microbial complexity and pathogen virulence. In: KETHEESAN, N. (ed.) *Melioidosis - A century of observation and research*. Elsevier B.V.
- NARITA, S.-I. & TOKUDA, H. 2007. Amino acids at positions 3 and 4 determine the membrane specificity of *Pseudomonas aeruginosa* lipoproteins. *Journal of Biological Chemistry*, 282, 13372-13378.
- NGAUY, V., LEMESHEV, Y., SADKOWSKI, L. & CRAWFORD, G. 2005. Cutaneous melioidosis in a man who was taken as a prisoner of war by the Japanese during World War II. *Journal of Clinical Microbiology*, 43, 970-972.
- NGUGI, S. A., VENTURA, V. V., QAZI, O., HARDING, S. V., KITTO, G. B., ESTES, D. M., DELL, A., TITBALL, R. W., ATKINS, T. P., BROWN, K. A., HITCHEN, P. G. & PRIOR, J. L. 2010. Lipopolysaccharide from *Burkholderia thailandensis* E264 provides protection in a murine model of melioidosis. *Vaccine*, 28, 7551-5.
- NIERMAN, W. C., DESHAZER, D., KIM, H. S., TETTELIN, H., NELSON, K. E., FELDBLYUM, T., ULRICH, R. L., RONNING, C. M., BRINKAC, L. M., DAUGHERTY, S. C., DAVIDSEN, T. D., DEBOY, R. T., DIMITROV, G., DODSON, R. J., DURKIN, A. S., GWINN, M. L., HAFT, D. H., KHOURI, H., KOLONAY, J. F., MADUPU, R., MOHAMMOUD, Y., NELSON, W. C., RADUNE, D., ROMERO, C. M., SARRIA, S., SELENGUT, J., SHAMBLIN, C., SULLIVAN, S. A., WHITE, O., YU, Y., ZAFAR, N., ZHOU, L. & FRASER, C. M. 2004. Structural flexibility in the *Burkholderia mallei* genome. *Proceedings of the National Academy of Sciences of the United States of America*, 101, 14246 - 14251.
- NIKAIDO, H. 2003. Molecular basis of bacterial outer membrane permeability revisited. *Microbiology and Molecular Biology Reviews*, 67, 593-656.
- NIKAIDO, H. 2005. Restoring permeability barrier function to outer membrane. *Chemistry & Biology*, 12, 507-509.
- NIKAIDO, H. & PAGÈS, J.-M. 2012. Broad specificity efflux pumps and their role in multidrug resistance of Gram-negative bacteria. *FEMS Microbiology Reviews*, 36, 340-363.
- NOVEM, V., SHUI, G., WANG, D., BENDT, A. K., SIM, S. H., LIU, Y., THONG, T. W., SIVALINGAM, S. P., OOI, E. E., WENK, M. R. & TAN, G. 2009. Structural and biological diversity of lipopolysaccharides from *Burkholderia pseudomallei* and *Burkholderia thailandensis*. *Clinical and vaccine immunology*, 16, 1420-8.
- O'BRIEN, C. R., KROCKENBERGER, M. B., MARTIN, P., PARKES, H., KIDD, M. & MALIK, R. 2003. Disseminated melioidosis in two cats. *Journal of Feline Medicine and Surgery*, 5, 83-89.
- OPPERMAN, T., LING, L. L. & MOIR, D. T. 2003. Microbial pathogen genomes – new strategies for identifying therapeutic and vaccine targets. *Expert Opinion on Therapeutic Targets*, 7, 469-473.
- PAI, R. K., CONVERY, M., HAMILTON, T. A., BOOM, W. H. & HARDING, C. V. 2003. Inhibition of IFN-gamma-induced class II transactivator expression by a 19-kDa lipoprotein from *Mycobacterium tuberculosis*: a potential mechanism for immune evasion. *Journal of Immunology*, 171, 175-184.

- PEACOCK, S. J., CHIENG, G., CHENG, A. C., DANCE, D. A. B., AMORNCHAI, P., WONGSUWAN, G., TEERAWATTANASOOK, N., CHIERAKUL, W., DAY, N. P. J. & WUTHIEKANUN, V. 2005. Comparison of Ashdown's medium, *Burkholderia cepacia* medium, and *Burkholderia pseudomallei* selective agar for clinical isolation of *Burkholderia pseudomallei*. *Journal of Clinical Microbiology*, 43, 5359-5361.
- PERRY, M. B., MACLEAN, L. L., SCHOLLAARDT, T., BRYAN, L. E. & HO, M. 1995. Structural characterization of the lipopolysaccharide O antigens of *Burkholderia pseudomallei*. *Infection and Immunity*, 63, 3348-52.
- PHAN, M.-D., PETERS, K. M., SARKAR, S., LUKOWSKI, S. W., ALLSOPP, L. P., MORIEL, D. G., ACHARD, M. E. S., TOTSIKA, M., MARSHALL, V. M., UPTON, M., BEATSON, S. A. & SCHEMBRI, M. A. 2013. The serum resistome of a globally disseminated multidrug resistant uropathogenic *Escherichia coli* clone. *PLoS Genetics*, 9, e1003834.
- PHEWKLIANG, A., WONGRATANACHEEWIN, S. & CHAREONSUDJAI, S. 2010. Role of *Burkholderia pseudomallei* in the invasion, replication and induction of apoptosis in human epithelial cell lines. *Southeast Asian Journal of Tropical Medicine and Public Health*, 41, 1164-76.
- PILATZ, S., BREITBACH, K., HEIN, N., FEHLHABER, B., SCHULZE, J., BRENNEKE, B., EBERL, L. & STEINMETZ, I. 2006. Identification of *Burkholderia pseudomallei* genes required for the intracellular life cycle and in vivo virulence. *Infection and Immunity*, 74, 3576-86.
- PLESA, M., HERNALSTEENS, J.-P., VANDENBUSSCHE, G., RUYSSCHAERT, J.-M. & CORNELIS, P. 2006. The SlyB outer membrane lipoprotein of *Burkholderia multivorans* contributes to membrane integrity. *Research in Microbiology*, 157, 582-592.
- PLESA, M., KHOLTI, A., VERMIS, K., VANDAMME, P., PANAGEA, S., WINSTANLEY, C. & CORNELIS, P. 2004. Conservation of the *opcL* gene encoding the peptidoglycan-associated outer-membrane lipoprotein among representatives of the *Burkholderia cepacia* complex. *Journal of Medical Microbiology*, 53, 389-398.
- PUKATZKI, S., MA, A. T., STURTEVANT, D., KRSTINS, B., SARRACINO, D., NELSON, W. C., HEIDELBERG, J. F. & MEKALANOS, J. J. 2006. Identification of a conserved bacterial protein secretion system in *Vibrio cholerae* using the *Dictyostelium* host model system. *Proceedings of the National Academy of Sciences of the United States of America*, 103, 1528-1533.
- PUTHUCHEARY, S. D., PARASAKTHI, N. & LEE, M. K. 1992. Septicaemic melioidosis: a review of 50 cases from Malaysia. *Transactions of the Royal Society of Tropical Medicine and Hygiene*, 86, 683-685.
- RAINBOW, L., HART, C. A. & WINSTANLEY, C. 2002. Distribution of type III secretion gene clusters in *Burkholderia pseudomallei*, *B. thailandensis* and *B. mallei*. *Journal of Medical Microbiology*, 51, 374-384.
- RAJA, N. S. 2008. Case of melioidosis in a university teaching hospital in Malaysia. *Journal of Microbiology, Immunology and Infection*, 41, 174-9.
- RATTANATHONGKOM, A., SERMSWAN, R. W. & WONGRATANACHEEWIN, S. 1997. Detection of *Burkholderia pseudomallei* in blood samples using polymerase chain reaction. *Molecular and Cellular Probes*, 11, 25-31.
- RATTANAVONG, S., WUTHIEKANUN, V., LANGLA, S., AMORNCHAI, P., SIRISOUK, J., PHETSOUVANH, R., MOORE, C. E., PEACOCK, S. J., BUISSON, Y. & NEWTON, P. N. 2011. Randomized soil survey of the distribution of *Burkholderia pseudomallei* in rice fields in Laos. *Applied and Environmental Microbiology*, 77, 532-536.

- RAVIKUMAR, B., SARKAR, S., DAVIES, J. E., FUTTER, M., GARCIA-ARENCIBIA, M., GREEN-THOMPSON, Z. W., JIMENEZ-SANCHEZ, M., KOROLCHUK, V. I., LICHTENBERG, M., LUO, S., MASSEY, D. C. O., MENZIES, F. M., MOREAU, K., NARAYANAN, U., RENNA, M., SIDDIQI, F. H., UNDERWOOD, B. R., WINSLOW, A. R. & RUBINSZTEIN, D. C. 2010. Regulation of mammalian autophagy in physiology and pathophysiology. *Physiological Reviews*, 90, 1383-1435.
- RECKSEIDLER-ZENTENO, S. L., DEVINNEY, R. & WOODS, D. E. 2005. The capsular polysaccharide of *Burkholderia pseudomallei* contributes to survival in serum by reducing complement factor C3b deposition. *Infection and Immunity*, 73, 1106-15.
- RECKSEIDLER, S. L., DESHAZER, D., SOKOL, P. A. & WOODS, D. E. 2001. Detection of bacterial virulence genes by subtractive hybridization: identification of capsular polysaccharide of *Burkholderia pseudomallei* as a major virulence determinant. *Infection and Immunity*, 69, 34-44.
- REYRAT, J. M., PELICIC, V., GICQUEL, B. & RAPPUOLI, R. 1998. Counters selectable markers : untapped tools for bacterial genetics and pathogenesis. *Infection and Immunity*, 66, 4011-4017.
- RIETSCHEL, E. T., KIRIKAE, T., SCHADE, F. U., MAMAT, U., SCHMIDT, G., LOPPNOW, H., ULMER, A. J., ZÄHRINGER, U., SEYDEL, U., DI PADOVA, F., SCHREIER, M. & BRADE, H. 1994. Bacterial endotoxin: molecular relationships of structure to activity and function. *FASEB Journal*, 8, 217-25.
- ROBBINS, J. B., MCCRACKEN, G. H., GOTSCHLICH, E. C., ØRSKOV, F., ØRSKOV, I. & HANSON, L. A. 1974. *Escherichia coli* K1 capsular polysaccharide associated with neonatal meningitis. *New England Journal of Medicine*, 290, 1216-1220.
- ROBERTS, I. S. 1996. The biochemistry and genetics of capsular polysaccharide production in bacteria. *Annual Review of Microbiology*, 50, 285-315.
- RONNING, C. M., LOSADA, L., BRINKAC, L., INMAN, J., ULRICH, R. L., SCHELL, M., NIERMAN, W. & DESHAZER, D. 2010. Genetic and phenotypic diversity in *Burkholderia*: contributions by prophage and phage-like elements. *BMC Microbiology*, 10, 202.
- ROOIJAKKERS, S. H. M. & VAN STRIJP, J. A. G. 2007. Bacterial complement evasion. *Molecular Immunology*, 44, 23-32.
- ROSENFELD, Y. & SHAI, Y. 2006. Lipopolysaccharide (endotoxin)-host defense antibacterial peptides interactions: Role in bacterial resistance and prevention of sepsis. *Biochimica et Biophysica Acta (BBA) - Biomembranes*, 1758, 1513-1522.
- ROTZ, L. D., KHAN, A. S., LILLIBRIDGE, S. R., OSTROFF, S. M. & HUGHES, J. M. 2002. Public health assessment of potential biological terrorism agents. *Emerging infectious diseases*, 8, 225-30.
- RUSSELL, A. B., PETERSON, S. B. & MOUGOUS, J. D. 2014. Type VI secretion system effectors: poisons with a purpose. *Nature Reviews: Microbiology*, 12, 137-148.
- SARKAR-TYSON, M., THWAITE, J. E., HARDING, S. V., SMITHER, S. J., OYSTON, P. C. F., ATKINS, T. P. & TITBALL, R. W. 2007. Polysaccharides and virulence of *Burkholderia pseudomallei*. *Journal of medical microbiology*, 56, 1005-10.
- SARKAR-TYSON, M. & TITBALL, R. W. 2010. Progress toward development of vaccines against melioidosis: A review. *Clinical Therapeutics*, 32, 1437-1445.
- SCHELL, M. A., ULRICH, R. L., RIBOT, W. J., BRUEGGEMANN, E. E., HINES, H. B., CHEN, D., LIPSCOMB, L., KIM, H. S., MRÁZEK, J., NIERMAN, W. C. & DESHAZER, D. 2007. Type VI secretion is a major virulence determinant in *Burkholderia mallei*. *Molecular microbiology*, 64, 1466-85.
- SCHELL, M. A., ZHAO, P. & WELLS, L. 2011. Outer membrane proteome of *Burkholderia pseudomallei* and *Burkholderia mallei* from diverse growth conditions. *Journal of proteome research*, 10, 2417-24.



- SCHUCH, R. & MAURELLI, A. T. 1999. The mxi-Spa type III secretory pathway of *Shigella flexneri* requires an outer membrane lipoprotein, MxiM, for invasin translocation. *Infection and Immunity*, 67, 1982-91.
- SCHWARZ, S., WEST, T. E., BOYER, F., CHIANG, W.-C., CARL, M. A., HOOD, R. D., ROHMER, L., TOLKER-NIELSEN, T., SKERRETT, S. J. & MOUGOUS, J. D. 2010. *Burkholderia* type VI secretion systems have distinct roles in eukaryotic and bacterial cell interactions. *PLoS Pathogens*, 6, e1001068.
- SCHWEIZER, H. P. 2012a. Mechanisms of antibiotic resistance in *Burkholderia pseudomallei*: implications for treatment of melioidosis. *Future Microbiology*, 7, 1389-1399.
- SCHWEIZER, H. P. 2012b. When it comes to drug discovery not all Gram-negative bacterial biodefence pathogens are created equal: *Burkholderia pseudomallei* is different. *Microbial Biotechnology [electronic resource]*, 5, 581-583.
- SEIB, K. L., SERRUTO, D., ORIENTE, F., DELANY, I., ADU-BOBIE, J., VEGGI, D., ARICÒ, B., RAPPUOLI, R. & PIZZA, M. 2009. Factor H-binding protein is important for meningococcal survival in human whole blood and serum and in the presence of the antimicrobial peptide LL-37. *Infection and Immunity*, 77, 292-299.
- SHA, J., AGAR, S. L., BAZE, W. B., OLANO, J. P., FADL, A. A., EROVA, T. E., WANG, S., FOLTZ, S. M., SUAREZ, G., MOTIN, V. L., CHAUHAN, S., KLIMPEL, G. R., PETERSON, J. W. & CHOPRA, A. K. 2008. Braun lipoprotein (Lpp) contributes to virulence of yersiniae: Potential role of Lpp in inducing bubonic and pneumonic plague. *Infection and Immunity*, 76, 1390-1409.
- SHALOM, G., SHAW, J. G. & THOMAS, M. S. 2007. *In vivo* expression technology identifies a type VI secretion system locus in *Burkholderia pseudomallei* that is induced upon invasion of macrophages. *Microbiology*, 153, 2689-99.
- SHAMS, A. M., ROSE, L. J., HODGES, L. & ARDUINO, M. J. 2007. Survival of *Burkholderia pseudomallei* on environmental surfaces. *Applied and environmental microbiology*, 73, 8001-4.
- SILHAVY, T. J., KAHNE, D. & WALKER, S. 2010. The bacterial cell envelope. *Cold Spring Harbor Perspectives in Biology [electronic resource]*, 2, a000414.
- SILVA-HERZOG, E., FERRACCI, F., JACKSON, M. W., JOSEPH, S. S. & PLANO, G. V. 2008. Membrane localization and topology of the *Yersinia pestis* YscJ lipoprotein. *Microbiology*, 154, 593-607.
- SILVA, E. B. & DOW, S. W. 2013. Development of *Burkholderia mallei* and *pseudomallei* vaccines. *Frontiers in Cellular and Infection Microbiology [electronic resource]*, 3, 10.
- SIM, B. M. Q., CHANTRATITA, N., OOI, W. F., NANDI, T., TEWHEY, R., WUTHIEKANUN, V., THAI PADUNGPANIT, J., TUMAPA, S., ARIYARATNE, P., SUNG, W.-K., SEM, X. H., CHUA, H. H., RAMNARAYANAN, K., LIN, C. H., LIU, Y., FEIL, E. J., GLASS, M. B., TAN, G., PEACOCK, S. J. & TAN, P. 2010. Genomic acquisition of a capsular polysaccharide virulence cluster by non- pathogenic *Burkholderia* isolates. *Genome Biology* 11, R89.
- SIM, S. H., YU, Y., LIN, C. H., KARUTURI, R. K. M., WUTHIEKANUN, V., TUANYOK, A., CHUA, H. H., ONG, C., PARAMALINGAM, S. S., TAN, G., TANG, L., LAU, G., OOI, E. E., WOODS, D., FEIL, E., PEACOCK, S. J. & TAN, P. 2008. The core and accessory genomes of *Burkholderia pseudomallei*: Implications for human melioidosis. *PLoS Pathogens*, 4, e1000178.
- SITTHIDET, C., KORBSRISATE, S., LAYTON, A. N., FIELD, T. R., STEVENS, M. P. & STEVENS, J. M. 2011. Identification of motifs of *Burkholderia pseudomallei* BimA required for intracellular motility, actin binding and actin polymerization. *Journal of Bacteriology*, 193, 1901-10.

- SITTHIDET, C., STEVENS, J. M., CHANTRATITA, N., CURRIE, B. J., PEACOCK, S. J., KORBSRISATE, S. & STEVENS, M. P. 2008. Prevalence and sequence diversity of a factor required for actin-based motility in natural populations of *Burkholderia* species. *Journal of clinical microbiology*, 46, 2418-22.
- SMITH, H. E., DAMMAN, M., VAN DER VELDE, J., WAGENAAR, F., WISSELINK, H. J., STOCKHOFE-ZURWIEDEN, N. & SMITS, M. A. 1999. Identification and characterization of the *cps* locus of *Streptococcus suis* serotype 2: the capsule protects against phagocytosis and is an important virulence factor. *Infection and Immunity*, 67, 1750-6.
- SMITH, M. D., ANGUS, B. J., WUTHIEKANUN, V. & WHITE, N. J. 1997. Arabinose assimilation defines a nonvirulent biotype of *Burkholderia pseudomallei*. *Infection and Immunity*, 65, 4319-4321.
- SPRAGUE, L. D. & NEUBAUER, H. 2004. Melioidosis in animals: A review on epizootiology, diagnosis and clinical presentation. *Journal of Veterinary Medicine. B: Infectious Diseases and Veterinary Public Health*, 51, 305-320.
- STANTON, A. T., FLETCHER, W. & KANAGARAYER, K. 1924. Two cases of melioidosis. *Journal of Hygiene*, 23, 268-276.7.
- STEVENS, J. M., GALYOV, E. E. & STEVENS, M. P. 2006. Actin-dependent movement of bacterial pathogens. *Nature reviews: Microbiology*, 4, 91-101.
- STEVENS, J. M., ULRICH, R. L., TAYLOR, L. A., WOOD, M. W., DESHAZER, D., STEVENS, M. P. & GALYOV, E. E. 2005a. Actin-binding proteins from *Burkholderia mallei* and *Burkholderia thailandensis* can functionally compensate for the actin-based motility defect of a *Burkholderia pseudomallei bima* mutant. *Journal of Bacteriology*, 187, 7857-7862.
- STEVENS, M. P., FRIEBEL, A., TAYLOR, L. A., WOOD, M. W., BROWN, P. J., HARDT, W.-D. & GALYOV, E. E. 2003. A *Burkholderia pseudomallei* type III secreted protein, BopE, facilitates bacterial invasion of epithelial cells and exhibits guanine nucleotide exchange factor activity. *Journal of Bacteriology* 185, 4992-4996.
- STEVENS, M. P., HAQUE, A., ATKINS, T. P., HILL, J., WOOD, M. W., EASTON, A., NELSON, M., UNDERWOOD-FOWLER, C., TITBALL, R. W., BANCROFT, G. J. & GALYOV, E. E. 2004. Attenuated virulence and protective efficacy of a *Burkholderia pseudomallei bsa* type III secretion mutant in murine models of melioidosis. *Microbiology*, 150, 2669-76.
- STEVENS, M. P., STEVENS, J. M., JENG, R. L., TAYLOR, L. A., WOOD, M. W., HAWES, P., MONAGHAN, P., WELCH, M. D. & GALYOV, E. E. 2005b. Identification of a bacterial factor required for actin-based motility of *Burkholderia pseudomallei*. *Molecular Microbiology*, 56, 40-53.
- STEVENS, M. P., WOOD, M. W., TAYLOR, L. A., MONAGHAN, P., HAWES, P., JONES, P. W., WALLIS, T. S. & GALYOV, E. E. 2002. An Inv/Mxi-Spa-like type III protein secretion system in *Burkholderia pseudomallei* modulates intracellular behaviour of the pathogen. *Molecular Microbiology*, 46, 649-659.
- STROM, M. S. & LORY, S. 1993. Structure-function and biogenesis of the type IV pili. *Annual Review of Microbiology*, 47, 565-596.
- SUN, G. W., CHEN, Y., LIU, Y., TAN, G.-Y. G., ONG, C., TAN, P. & GAN, Y.-H. 2010. Identification of a regulatory cascade controlling type III secretion system 3 gene expression in *Burkholderia pseudomallei*. *Molecular Microbiology*, 76, 677-89.
- SUPUTTAMONGKOL, Y., CHAOWAGUL, W., CHETCHOTISAKD, P., LERTPATANASUWUN, N., INTARANONGPAI, S., RUCHUTRAKOOL, T., BUDHSARAWONG, D., MOOTSIKAPUN, P., WUTHIEKANUN, V., TEERAWATASOOK, N. & LULITANOND, A. 1999. Risk factors for melioidosis and bacteremic melioidosis. *Clinical Infectious Diseases*, 29, 408-413.

- SUPUTTAMONGKOL, Y., HALL, A. J., DANCE, D. A. B., CHAOWAGUL, W., RAJCHANUVONG, A., SMITH, M. D. & WHITE, N. J. 1994. The epidemiology of melioidosis in Ubon Ratchatani, northeast Thailand. *International Journal of Epidemiology*, 23, 1082-1090.
- SUZUKI, T., MURAI, T., FUKUDA, I., TOBE, T., YOSHIKAWA, M. & SASAKAWA, C. 1994. Identification and characterization of a chromosomal virulence gene, *vacJ*, required for intercellular spreading of *Shigella flexneri*. *Molecular Microbiology*, 11, 31-41.
- TAL, N. & SCHULDINER, S. 2009. A coordinated network of transporters with overlapping specificities provides a robust survival strategy. *Proceedings of the National Academy of Sciences of the United States of America*, 106, 9051-9056.
- TAN, A. L. & TAN, M.-L. 2008. Melioidosis: antibiogram of cases in Singapore 1987-2007. *Transactions of the Royal Society of Tropical Medicine and Hygiene*, 102, S101-102.
- TANDHAVANANT, S., THANWISAI, A., LIMMATHUROTSAKUL, D., KORBSRISATE, S., DAY, N. P. J., PEACOCK, S. J. & CHANTRATITA, N. 2010. Effect of colony morphology variation of *Burkholderia pseudomallei* on intracellular survival and resistance to antimicrobial environments in human macrophages in vitro. *BMC microbiology*, 10, 303.
- TAYLOR, P. W. 1983. Bactericidal and bacteriolytic activity of serum against Gram-negative bacteria. *Microbiological Reviews*, 47, 46-83.
- TITBALL, R. W., RUSSELL, P., CUCCUI, J., EASTON, A., HAQUE, A., ATKINS, T. P., SARKAR-TYSON, M., HARLEY, V., WREN, B. & BANCROFT, G. J. 2008. *Burkholderia pseudomallei*: animal models of infection. *Transactions of the Royal Society of Tropical Medicine and Hygiene*, 102, S111-116.
- TIYAWISUTSRI, R., PEACOCK, S. J., LANGA, S., LIMMATHUROTSAKUL, D., CHENG, A. C., CHIERAKUL, W., CHAOWAGUL, W., DAY, N. P. J. & WUTHIEKANUN, V. 2005. Antibodies from patients with melioidosis recognize *Burkholderia mallei* but not *Burkholderia thailandensis* antigens in the indirect hemagglutination assay. *Journal of Clinical Microbiology*, 43, 4872-4874.
- TOESCA, I. J., FRENCH, C. T. & MILLER, J. F. 2014. The type VI secretion system spike protein VgrG5 mediates membrane fusion during intercellular spread by *Pseudomallei* group *Burkholderia* species. *Infection and Immunity*, 82, 1436-1444.
- TOKUDA, H. 2009. Biogenesis of outer membranes in Gram-negative bacteria. *Bioscience, Biotechnology, and Biochemistry*, 73, 465-473.
- TOKUDA, H. & MATSUYAMA, S.-I. 2004. Sorting of lipoproteins to the outer membrane in *E. coli*. *Biochimica et Biophysica Acta*, 1693, 5 – 13.
- TOKUNAGA, M., TOKUNAGA, H. & WU, H. C. 1982. Post-translational modification and processing of *Escherichia coli* prolipoprotein in vitro. *Proceedings of the National Academy of Sciences of the United States of America*, 79, 2255-2259.
- TSENG, T.-T., TYLER, B. M. & SETUBAL, J. C. 2009. Protein secretion system in bacterial-host associations, and their description in the Gene Ontology. *BMC MICROBIOLOGY*, 9, S2.
- TUANYOK, A., AUERBACH, R. K., BRETTIN, T. S., BRUCE, D. C., MUNK, A. C., DETTER, J. C., PEARSON, T., HORNSTRA, H., SERMSWAN, R. W., WUTHIEKANUN, V., PEACOCK, S. J., CURRIE, B. J., KEIM, P. & WAGNER, D. M. 2007. A horizontal gene transfer event defines two distinct groups within *Burkholderia pseudomallei* that have dissimilar geographic distributions. *Journal of Bacteriology*, 189, 9044-9049.
- TUANYOK, A., LEADEM, B., AUERBACH, R. K., BECKSTROM-STERNBERG, S. M., BECKSTROM-STERNBERG, J. S., MAYO, M., WUTHIEKANUN, V., BRETTIN, T. S., NIERMAN, W. C., PEACOCK, S. J., CURRIE, B. J., WAGNER, D. M. & KEIM, P. 2008. Genomic islands from five strains of *Burkholderia pseudomallei*. *BMC genomics*, 9, 566.

- TUANYOK, A., STONE, J. K., MAYO, M., KAESTLI, M., GRUENDIKE, J., GEORGIA, S., WARRINGTON, S., MULLINS, T., ALLENDER, C. J., WAGNER, D. M., CHANTRATITA, N., PEACOCK, S. J., CURRIE, B. J. & KEIM, P. 2012. The genetic and molecular basis of O-antigenic diversity in *Burkholderia pseudomallei* lipopolysaccharide. *PLoS Neglected Tropical Diseases*, 6, e1453.
- TUMAPA, S., HOLDEN, M. T. G., VESARATCHAVEST, M., WUTHIEKANUN, V., LIMMATHUROTSAKUL, D., CHERAKUL, W., FEIL, E. J., CURRIE, B. J., DAY, N. P. J., NIERMAN, W. C. & PEACOCK, S. J. 2008. *Burkholderia pseudomallei* genome plasticity associated with genomic island variation. *BMC genomics*, 9, 190.
- U'REN, J. M., SCHUPP, J. M., PEARSON, T., HORNSTRA, H., FRIEDMAN, C. L. C., SMITH, K. L., DAUGHERTY, R. R. L., RHOTON, S. D., LEADEM, B., GEORGIA, S., CARDON, M., HUYNH, L. Y., DESHAZER, D., HARVEY, S. P., ROBISON, R., GAL, D., MAYO, M. J., WAGNER, D., CURRIE, B. J. & KEIM, P. 2007. Tandem repeat regions within the *Burkholderia pseudomallei* genome and their application for high resolution genotyping. *BMC Microbiology*, 7, 23.
- UTAISINCHAROEN, P., TANGTHAWORNCHAIKUL, N., KESPICHAYAWATTANA, W., CHAISURIYA, P. & SIRISINHA, S. 2001. *Burkholderia pseudomallei* interferes with inducible nitric oxide synthase (iNOS) production: a possible mechanism of evading macrophage killing. *Microbiology and Immunology*, 45, 307-313.
- VAN OPIJNEN, T. & CAMILLI, A. 2010. Genome-wide fitness and genetic interactions determined by Tn-seq, a high-throughput massively parallel sequencing method for microorganisms. *Current Protocols in Microbiology*, 19, 1E.3.1-1E.3.16.
- WAND, M. E., MÜLLER, C. M., TITBALL, R. W. & MICHELL, S. L. 2011. Macrophage and *Galleria mellonella* infection models reflect the virulence of naturally occurring isolates of *B. pseudomallei*, *B. thailandensis* and *B. oklahomensis*. *BMC microbiology*, 11, 11-11.
- WARAWA, J. M., LONG, D., ROSENKE, R., GARDNER, D. & GHERARDINI, F. C. 2009. Role for the *Burkholderia pseudomallei* capsular polysaccharide encoded by the *wcb* operon in acute disseminated melioidosis. *Infection and Immunity*, 77, 5252-5261.
- WARD, C. K., LAWRENCE, M. L., VEIT, H. P. & INZANA, T. J. 1998. Cloning and mutagenesis of a serotype-specific DNA region involved in encapsulation and virulence of *Actinobacillus pleuropneumoniae* serotype 5a: concomitant expression of serotype 5a and 1 capsular polysaccharides in recombinant *A. pleuropneumoniae* serotype 1. *Infection and Immunity*, 66, 3326-3336.
- WEST, T. E., FREVERT, C. W., LIGGITT, H. D. & SKERRETT, S. J. 2008. Inhalation of *Burkholderia thailandensis* results in lethal necrotizing pneumonia in mice: a surrogate model for pneumonic melioidosis. *Transactions of the Royal Society of Tropical Medicine and Hygiene*, 102, S119-S126.
- WHEELIS, M. 1998. First shots fired in biological warfare. *Nature*, 395, 213-213.
- WHITE, N. J. 2003. Melioidosis. *Lancet*, 361, 1715-1722.
- WHITLOCK, G. C., MARK ESTES, D. & TORRES, A. G. 2007. Glanders: off to the races with *Burkholderia mallei*. *FEMS Microbiology Letters*, 277, 115-122.
- WHITMORE, A. & KRISHNASWAMI, C. S. 1912. An account of the discovery of a hitherto undescribed infective disease occurring among the population of Rangoon. . *Indian Medical Gazette*, 47, 262-267.
- WIERSINGA, W. J., CURRIE, B. J. & PEACOCK, S. J. 2012. Melioidosis. *New England Journal of Medicine*, 367, 1035-1044.
- WIERSINGA, W. J., VAN DER POLL, T., WHITE, N. J., DAY, N. P. J. & PEACOCK, S. J. 2006. Melioidosis: insights into the pathogenicity of *Burkholderia pseudomallei*. *Nature Reviews: Microbiology*, 4, 272-282.

- WIKRAIPHAT, C., CHAROENSAP, J., UTAISINCHAROEN, P., WONGRATANACHEEWIN, S., TAWEECHASUPAPONG, S., WOODS, D. E., BOLSCHER, J. G. M. & SIRISINHA, S. 2009. Comparative *in vivo* and *in vitro* analyses of putative virulence factors of *Burkholderia pseudomallei* using lipopolysaccharide, capsule and flagellin mutants. *FEMS Immunology and Medical Microbiology*, 56, 253-259.
- WILKINSON, K. A., NEWTON, S. M., STEWART, G. R., MARTINEAU, A. R., PATEL, J., SULLIVAN, S. M., HERRMANN, J.-L., NEYROLLES, O., YOUNG, D. B. & WILKINSON, R. J. 2009. Genetic determination of the effect of post-translational modification on the innate immune response to the 19 kDa lipoprotein of *Mycobacterium tuberculosis*. *BMC Microbiology*, 9, 93.
- WINSOR, G. L., KHAIRA, B., VAN ROSSUM, T., LO, R., WHITESIDE, M. D. & BRINKMAN, F. S. L. 2008. The *Burkholderia* Genome database: facilitating flexible queries and comparative analyses. *Bioinformatics*, 24, 2803-2804.
- WONGRATANACHEEWIN, S. & SIRISINHA, S. 2012. Epidemiology of melioidosis in Thailand. In: KETHEESAN, N. (ed.) *Melioidosis - A century of observation and research*. Elsevier B.V.
- WOODMAN, M. E., WORTH, R. G. & WOOTEN, R. M. 2012. Capsule influences the deposition of critical complement C3 Levels required for the killing of *Burkholderia pseudomallei* via NADPH-oxidase induction by human neutrophils. *PLoS ONE*, 7, e52276.
- WU, H.-J., WANG, A. H. J. & JENNINGS, M. P. 2008. Discovery of virulence factors of pathogenic bacteria. *Current Opinion in Chemical Biology*, 12, 93-101.
- WUTHIEKANUN, V., AMORNCHAI, P., SAIPROM, N., CHANTRATITA, N., CHIERAKUL, W., KOH, G. C. K. W., CHAOWAGUL, W., DAY, N. P. J., LIMMATHUROTSAKUL, D. & PEACOCK, S. J. 2011. Survey of antimicrobial resistance in clinical *Burkholderia pseudomallei* isolates over two decades in Northeast Thailand. *Antimicrobial Agents and Chemotherapy*, 55, 5388-5391.
- WUTHIEKANUN, V., ANUNTAGOOL, N., WHITE, N. J. & SIRISINHA, S. 2002. Short report: a rapid method for the differentiation of *Burkholderia pseudomallei* and *Burkholderia thailandensis*. *The American Journal of Tropical Medicine and Hygiene*, 66, 759-61.
- WUTHIEKANUN, V., CHIERAKUL, W., LANGA, S., CHAOWAGUL, W., PANPITPAT, C., SAIPAN, P., THOUJAIKONG, T., DAY, N. P. J. & PEACOCK, S. J. 2006. Development of antibodies to *Burkholderia pseudomallei* during childhood in melioidosis - endemic northeast Thailand. *The American Journal of Tropical Medicine and Hygiene*, 74, 1074-1075.
- WUTHIEKANUN, V., LIMMATHUROTSAKUL, D., CHANTRATITA, N., FEIL, E. J., DAY, N. P. J. & PEACOCK, S. J. 2009. *Burkholderia pseudomallei* is genetically diverse in agricultural land in northeast Thailand. *PLoS Neglected Tropical Diseases*, 3, e496.
- WUTHIEKANUN, V., SMITH, M. D., DANCE, D. A. B., WALSH, A. L., PITT, T. L. & WHITE, N. J. 1996. Biochemical characteristics of clinical and environmental isolates of *Burkholderia pseudomallei*. *Journal of Medical Microbiology*, 45, 408-412.
- WUTHIEKANUN, V., SMITH, M. D., DANCE, D. A. B. & WHITE, N. J. 1995. Isolation of *Pseudomonas pseudomallei* from soil in north-eastern Thailand. *Transactions of the Royal Society of Tropical Medicine and Hygiene*, 89, 41 - 43.
- YAMAGUCHI, K., YU, F. & INOUE, M. 1988. A single amino acid determinant of the membrane localization of lipoproteins in *E. coli*. *Cell*, 53, 423-432.
- YOSHIKAWA, Y., OGAWA, M., HAIN, T., YOSHIDA, M., FUKUMATSU, M., KIM, M., MIMURO, H., NAKAGAWA, I., YANAGAWA, T., ISHII, T., KAKIZUKA, A., SZTUL, E., CHAKRABORTY, T. & SASAKAWA, C. 2009. *Listeria monocytogenes* ActA-mediated escape from autophagic recognition. *Nature Cell Biology*, 11, 1233-1240.

- YU, N. Y., WAGNER, J. R., LAIRD, M. R., MELLI, G., REY, S., LO, R., DAO, P., SAHINALP, S. C., ESTER, M., FOSTER, L. J. & BRINKMAN, F. S. L. 2010. PSORTb 3.0: improved protein subcellular localization prediction with refined localization subcategories and predictive capabilities for all prokaryotes. *Bioinformatics*, 26, 1608-1615.
- YU, Y., KIM, H. S., CHUA, H. H., CHI, H. L., SIM, S. H., LIN, D., DERR, A., ENGELS, R., DESHAZER, D., BIRREN, B., NIERMAN, W. & TAN, P. 2006. Genomic patterns of pathogen evolution revealed by comparison of *Burkholderia pseudomallei*, the causative agent of melioidosis, to avirulent *Burkholderia thailandensis*. *BMC MICROBIOLOGY*, 6, 46.
- ZAVASCKI, A. P., GOLDANI, L. Z., LI, J. & NATION, R. L. 2007. Polymyxin B for the treatment of multidrug-resistant pathogens: a critical review. *Journal of Antimicrobial Chemotherapy*, 60, 1206-1215.

## A. Appendices

### Appendix 1

**Table A.1 Solutions used in this study**

Reagent/buffer	Components	Use
TE buffer	100 mM Tris HCl pH 8.0, 200 mM NaCl, 5 mM EDTA, 0.2 % SDS (Fischer scientific Loughborough, Leicestershire, UK)	Genomic DNA extraction and electrophoresis solutions
Tris acetate EDTA (TAE) Buffer (50 x stock solution)	242 g Tris base, 100 ml 0.5 M EDTA, 57.1 ml Acetic acid to a final volume of 1 L (1 x = 40 mM Tris-acetate, 1 mM EDTA)	Gel electrophoresis
Sample loading buffer (2 x)	100 mM Tris.HCl, pH 6.8, 20 % (v/v) glycerol, 2 % SDS, 0.02 % (w/v) bromophenol blue, 0.1 M DTT	SDS-PAGE
20 x MOPS SDS Running buffer (NuPAGE®)	50 mM MOPS, 50 mM Tris base, 0.1 % SDS, 1 mM EDTA, pH 7.7	SDS-PAGE
Coomassie Stain	0.1 % Coomassie R250, 10 % acetic acid, 40 % methanol	SDS-PAGE
Destain solution	20 % methanol, 10 % acetic acid	SDS-PAGE
Tris-glycine running buffer	25 mM Tris-HCl pH 8.3, 250 mM glycine, 0.1 % (v/v) SDS	Western Blot
Transfer buffer (1x)	25 mM Tris, 200 mM glycine, 20 % methanol, 0.02% (v/v) SDS	Western Blot
PBST	Phosphate buffered saline (PBS), 0.01 % (v/v) Tween 20	Western Blot, immunofluorescence assay

## Appendix 2

### Construction of complementation vector with kanamycin resistance

The shuttle plasmid pME6033 was derived from pME6032 (a gift from Jo Stevens (Heeb et al., 2002)), where the tetracycline resistance cassette was replaced at the BamHI and XbaI sites with the PCR-amplified kanamycin resistance cassette from the plasmid vector pUT-Km2-A1 (Lorenzo et al., 1990).

**Table A.2 Primers used in replacement of antibiotic cassette in pME6032**

Primer	Sequence (5' to 3')	Use	Reference
Km-Up-BamHI	aaaag_gatc_cCAACAAAGCCACGTTGTGTCTCAA	PCR amplification of kanamycin cassette	This study
Km-Dn-XbaI	aaaat_ctag_aAGTCAGCGTAATGCTCTGCCAGT		
P6033F	TGGAAAGCGGGCAGTGAGCG	Sequencing primer to check replacement of KanR cassette	This study
Km2 UR	ATGCAACCGGCGCAGGAACA		

pME6033 is a shuttle vector with *E. coli* p15A origins and *Pseudomonas* plasmid pVS1 for stable replication in *E. coli* and *B. pseudomallei*. The p15A origin is a medium copy origin, about 15-25 copies per cell, and can be used in combination with pBR322-derived plasmids as a stable 2-plasmid system. The *Pseudomonas* plasmid pVS1, has about seven copies per cell is compatible with IncP-1 and IncP-4 replicons.



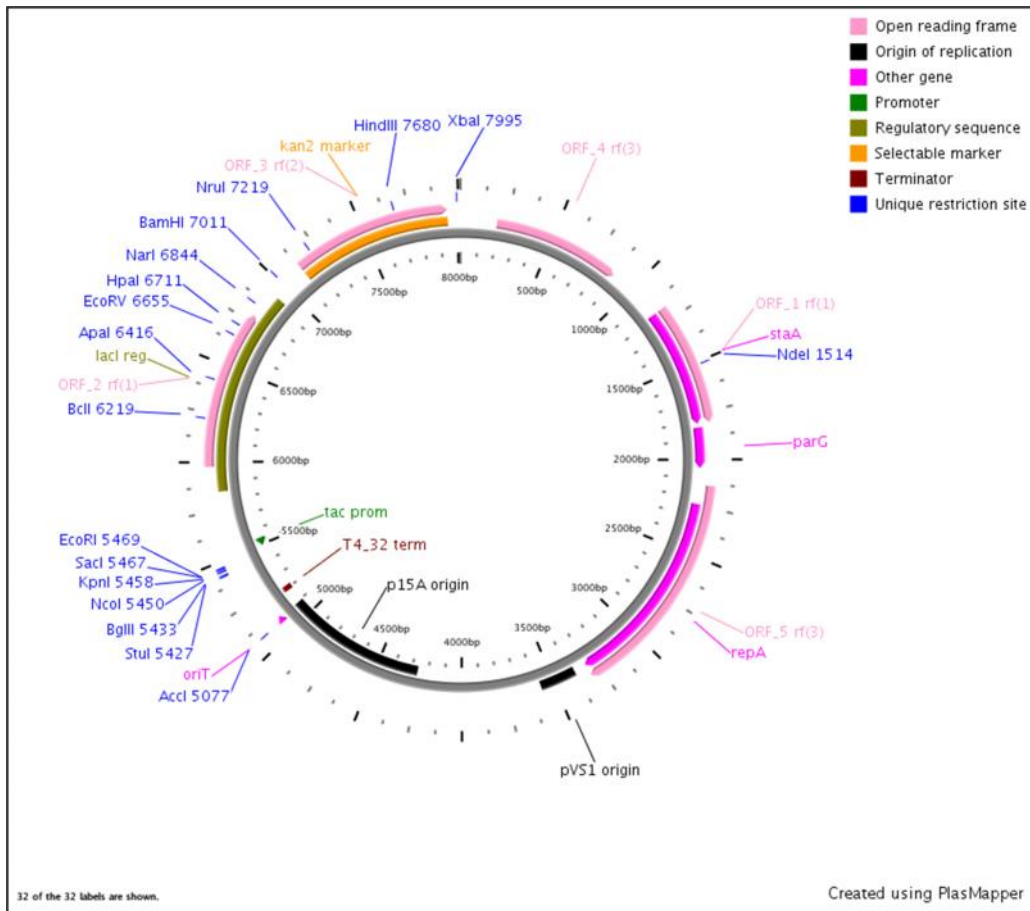

Figure A.1 Plasmid map of pMEK

>pMEK 8013 nt

TGATCCAACCCCTCCGCTGCTATAGTGCAGTCGGCTTCTGACGTTTCAGTGCAGCCGTTCTTGAAAACGACAT  
GTCGCACAAGTCTTAAGTTACGCGACAGGCTGCCGCCCTGCCCTTTTCTGGCGTTTTCTTGTCGCGTGT  
AGTCGCATAAAGTAGAATACTTGCAGCTAGAACCAGGACATTACGCCATGAACAAGAGCGCCGCCGCTGGC  
CTGCTGGGCTATGCCGCGTCAGCACCGACGACCAGGACTTGACCAACCAACGGGCCAACTGCACGCGGC  
CGGCTGCACCAAGCTGTTTTCCGAGAAGATCACCGGCACCAGGCGCGACCGCCCGGAGCTGGCCAGGATGC  
TTGACCACCTACGCCCTGGCGACGTTGTGACAGTGACCAGGCTAGACCGCCCTGGCCCGCAGCACCCGCGAC  
CTACTGGACATTGCCGAGCGCATCCAGGAGGCCGGCGCGGGCCTGCGTAGCCTGGCAGAGCCGTGGGCCGA  
CACCACCACGCCGGCCGGCCGCATGGTGTGACCGTGTTCGCCGCATTGCCGAGTTCGAGCGTTCCCTAAT  
CATCGACCGCACCCGGAGCGGGCGCGAGGCCGCCAAGGCCCGAGGCGTGAAGTTTGCCCCCGCCCTACC  
CTACCCCGGCACAGATCGCGCACGCCCGCGAGCTGATCGACCAGGAAGGCCGCACCGTGAAGAGGCGGC  
TGACTGCTTGGCGTGCATCGCTCGACCCTGTACCGCGCACTTGAGCGCAGCGAGGAAGTGACGCCACCGA  
GGCCAGGCGGCGCGGTGCCCTCCGTGAGGACGATTGACCGAGGCCGACGCCCTGGCGGCCCGCGAGAAT  
GAACGCCAAGAGGAACAAGCATGAAACCGCACCCAGGACGCCCAGGACGAACCGTTTTTCATTACCGAAGAGA  
TCGAGGCGGAGATGATCGCGGCCGGTACGTGTTTCGAGCCGCCCGCGCACGCTCAACCGTGGCGTGCAT  
GAAATCCTGGCCGTTTGTCTGATGCCAAGCTGGCGGCCCTGGCCGGCCAGCTTGGCCGCTGAAGAAACCGAG  
CGCCGCCGTCTAAAAAGGTGATGTGTATTTGAGTAAAAACAGCTTGCCTCATGCGGTGCTGCGTATATGATGC  
GATGAGTAAATAACAAATACGCAAGGGGAACGCATGAAGTTATCGCTGTACTTAACCAGAAAAGCGGGTCA  
GGCAAGACGACCATCGCAACCCATCTAGCCCGGCCCTGCAACTCGCCGGGGCCGATGTTCTGTAGTCGAT  
TCCGATCCCCAGGGCAGTGCCCGCGATTGGGCGGCCGTGCGGGAAGATCAACCGCTAACCGTTGTCGGCAT  
CGACCGCCCGACGATTGACCGCGACGTGAAGGCCATCGGCCGGCGCGACTTCGTAGTGATCGACGGAGCGC  
CCCAGGCGGCGGACTTGGCTGTGTCGCGATCAAGGCAGCCGACTTCGTGCTGATTCCGGTGCAGCCAAGC  
CCTTACGACATATGGGCCACCGCCGACCTGGTGGAGCTGGTTAAGCAGCGCATTGAGGTCACGGATGGAAGG  
CTACAAGCGGCCTTTGTCGTGTCGCGGGCGATCAAAGGCACGCGCATCGGCGGTGAGGTTGCCGAGGCGCT  
GGCCGGGTACGAGCTGCCATTCTTGTAGTCCCGTATCACGCAGCGCGTGAGCTACCCAGGCACTGCCGCCG  
CCGGCACAACCGTTCTTGAATCAGAACCCGAGGGCGACGCTGCCCGCGAGGTCCAGGCGCTGGCCGCTGAA  
ATTAATCAAACCTATTTGAGTTAATGAGGTAAGAGAAAAATGAGCAAAAAGCACAACACGCTAAGTGCCGGC  
CGTCCGAGCGCACGCAGCAGCAAGGCTGCAACGTTGGCCAGCCTGGCAGACACGCCAGCCATGAAGCGGGT  
CAACTTTCAGTTGCCGGCGGAGGATCACACCAAGCTGAAGATGTACGCGGTACGCCAAGGCAAGACCATTAC  
CGAGCTGCTATCTGAATACATCGCGCAGCTACCAGAGTAAATGAGCAAATGAATAAATGAGTAGATGAATTTA  
GCGGCTAAAGGAGGCGGCATGGAATAAAGAAACAACAGGACCCGACGCCGTGGAATGCCCATGTGTGGA  
GGAACGGGCGGTTGGCCAGGCGTAAGCGGCTGGGTTGTCTGCCGGCCCTGCAATGGCACTGGAACCCCAA  
GCCCGAGGAATCGGCGTGAGCGGTGCAACCATCCGGCCCGGTACAAATCGGCGCGGCGCTGGGTGATGA  
CCTGGTGGAGAAGTTGAAGGCCGCGCAGGCCGCCAGCGGCAACGCATCGAGGCAGAAGCACGCCCCGGT  
GAATCGTGGCAAGCGGCCGCTGATCGAATCCGAAAGAATCCCGGCAACCGCCGGCAGCCGGTGGCGCGTC  
GATTAGGAAGCCGCCAAGGGCGACGAGCAACCAGATTTTTTTCGTTCCGATGCTCTATGACGTGGGCACCCG  
CGATAGTCGCAGCATCATGGACGTGGCCGTTTTCCGTCTGTGCAAGCGTGACCGACGAGCTGGCGAGGTGAT  
CCGCTACGAGCTTCCAGACGGGCACGTAGAGGTTTCCGCGAGGGCCGGCCGGCATGGCCAGTGTGTGGATT  
ACGACCTGGTACTGATGGCGTTTTCCATCTAACCGAATCCATGAACCGATACCGGGAAGGGAAGGGAGACA  
AGCCCGGCCGCGTGTCCGTCCACACGTTGCGGACGTAAGTTCTGCCGGCGAGCCGATGGCGGAAAG  
CAGAAAGACGACCTGGTAGAAACCTGCATTCCGTTAAACACCACGCACGTTGCCATGCAGCGTACGAAGAAG  
CCAAGAACGGCCGCTGGTACGGTATCCGAGGGTGAAGCCTTGATTAGCCGCTACAAGATCGTAAAGAGCG  
AAACCGGGCGGCGGAGTACATCGAGATCGAGCTAGCTGATTGGATGTACCGCGAGATCACAGAAGGCAAGA  
ACCCGACGTGCTGACGGTTACCCCGATTACTTTTTGATCGATCCCGGCATCGGCCGTTTTCTCTACCGCT  
GGCACGCCGCGCCGAGGCAAGGCAAGCCAGATGGTTGTTCAAGACGATCTACGAACGCAGTGGCAGCG  
CCGGAGAGTTCAAGAAGTTCTGTTTACCGTGCAGCAAGCTGATCGGGTCAAATGACCTGCCGGAGTACGATTT  
GAAGGAGGAGGCGGGCAGGCTGGCCCGATCCTAGTCATGCGCTACCGCAACCTGATCGAGGGCGAAGCAT  
CCGCCGGTTCCTAATGTACGGAGCAGATGCTAGGGCAAATTGCCCTAGCAGGGGAAAAAGGTGAAAAAGGTC  
TCTTTCCTGTGGATAGCACGTACATTGGGAACCCAAAGCCGTACATTGGGAACCGGAACCCGTACATTGGGAA  
CCCAAAGCCGTACATTGGGAACCGGTACACATGTAAGTGACTGATATAAAAGAGAAAAAGGCGATTTTTCCG

CCTAAACTCTTTAAACTTATTAAACTCTTAAACCCGCCTGGCCTGTGCATAACTGTCTGCCAGCGCACA  
GCCGAAGAGCTGCAAAAAGCGCCTACCCTTCGGTGCCTGCGCTCCCTACGCCCCCGCCTTCGCGTGGCCT  
ATCGCGGCCGCTGGCCGCTCAAAAATGGCTGGCCTACGGCCAGGCAATCTACCAGGCGCGGACAAGCCGC  
GCCGTCGCCACTCGACCGCCGGCGCTGAGGTCTGCCTCGTGAAGAAGGTGTTGCTGACTCATAACCAGGGCAA  
TGGCAACAACGTTGCGCAAATTAAGTGGCGAACTACTTACTCTAGCTTCCCGGCAACAATTAATAGACTGG  
ATGGAGGCGGATAAAGTTGCAGGACCCTTCTGCGCTCGGCCCTCCGGCTGGCTGGTTTATTGCTGATAAAT  
CTGGAGCCGGTGAGCGTGGGTCTCGCGGTATCATTGCAGCACTGGGGCCAGATGGTAAGCCCTCCCGTATCG  
TAGTTATCTACACGACGGGAGTCAAGCAACTATGGATGAACGAAATAGACAGATCGCTGAGATAGGTGCCTC  
ACTGATTAAGCATTGGTAACTGTGACACCAAGTTTACTCATATATACTTTAGATTGATTTAAAACCTCATTITTAAT  
TAAAAGGATCTAGGTGAAGATCCTTTTTGATAATCTCATGACAAAATCCCTTAACGTGAGTTTTCGTCCACT  
GAGCGTCAGACCCCTTAATAAGATGATCTTCTGAGATCGTTTTGGTCTGCGCGTAATCTCTTGCTCTGAAAAC  
GAAAAACCGCTTGCAGGGCGGTTTTTGAAGGTTCTCTGAGCTACCAACTCTTTGAACCGAGGTAACCTGGC  
TTGGAGGAGCGCAGTACCAAACTTGTCTTTCAGTTTAGCCTTAACCGGCGCATGACTTCAAGACTAACTCC  
TCTAAATCAATTACCAGTGGCTGCTGCCAGTGGTGTCTTTCATGTCTTTCGGGTTGGACTCAAGACGATAGT  
TACCGGATAAGGCGCAGCGGTGGACTGAACGGGGGGTTCGTGCATACAGTCCAGCTTGGAGCGAACTGCCT  
ACCCGGAAGTGAAGTGTGAGGCGTGAATGAGACAAACGCGGCCATAACAGCGGAATGACACCGGTAACCGA  
AAGGCAGGAACAGGAGAGCGCACGAGGGAGCCGCCAGGGGAAACGCGCTGGTATCTTTATAGTCTGTGCGG  
GTTTCGCCACCACTGATTTGAGCGTCAGATTTCTGATGCTTGTGAGGGGGCGGAGCCTATGAAAAACGGC  
TTTGCCGCGGCCCTCTCACTTCCCTGTTAAGTATCTTCTGGCATCTTCCAGGAAATCTCCGCCCGTTTGTAA  
GCCATTTCCGCTCGCCGAGTCAACGACCGAGCGTAGCGAGTCAAGTGAAGCGGAAAGCGGAATATATCCTG  
TATCACATATTCTGCTGACGCACCGGTGCAGCCTTTTTTCTCCTGCCACATGAAGCACTTCACTGACACCCTCA  
TCAGTGCCAAATAGTAAGCCAGTATACACTCCGCTAGCGCTGAGGTCTGCCTCGTGAAGAAGGTGTTGCTGA  
CTCATAACCAGGCTAGTCCGAGGAGCTTATGCTTGTAAACCGTTTTGTGAAAAATTTTTAAAATAAAAAAGGGG  
ACCTCTAGGGTCCCAATTAATTAGTAATATAATCTATTAAGGTCAATCAAAAGGTCAATCCACCGGATCAATTC  
CCCTGCTCGCGCAGGCTGGGTGCCAAGCTCTCGGGTAACATCAAGGCCCGATCCTTGGAGCCCTTGCCCTCC  
CGCACGATGATCGTGCCGTGATCGAAATCCAGATCCTTGACCCGAGTTGCAAACCCCTCACTGATCCGCTAGT  
CCGAGGCCTCGAGATCTATCGATGCATGCCATGGTACCCGGGAGCTCGAATTCTGTTTCCTGTGTGAAATTTGT  
TATCCGCTCACAATTCCACACATTATACGAGCCGATGATTAATTGTCAACAGCTCATTTCAGAATATTTGCCAGA  
ACCGTTATGATGTGCGCGCAAAAAACATTATCCAGAACGGGAGTGCCTTGGAGCGACACGAATTATGCAGTG  
ATTTACGACCTGCACAGCCATACCACAGCTTCCGATGGCTGCCTGACGCCAGAAGCATTGGTGCACCGTGCAG  
TCGATAAGCCCGGATCAGCTTGCAATTCGCGCGCAAGGCGAAGCGGCATGCATTTACGTTGACACCATCGAA  
TGGTGCAAAACCTTTCGCGGTATGGCATGATAGCGCCCGAAGAGAGTCAATTCAGGGTGGTGAATGTGAAAC  
CAGTAACGTTATACGATGTGCGAGAGTATGCCGGTGTCTTTATCAGACCGTTTCCGCGTGGTGAACCAGGC  
CAGCCACGTTTCTGCGAAAACGCGGGAAAAAGTGAAGCGGCGATGGCGGAGCTGAATTACATTTCCAAACCG  
CGTGGCACAACAACTGGCGGGCAACAGTCTGTGCTGATTGGCGTTGCCACCTCCAGTCTGGCCCTGCACGC  
GCCGTCGCAATTTGTCGCGGCGATTAATCTCGCGCCGATCAACTGGGTGCCAGCGTGGTGGTGTGATGGT  
AGAACGAAGCGGCGTGAAGCCTGTAAAGCGGCGGTGCACAATCTTCTCGCGCAACCGCTCAGTGGGCTGAT  
CATTAACTATCCGCTGGATGACCAGGATGCCATTGCTGTGGAAGCTGCCTGCACTAATGTTCCGGCGTTATTTT  
TTGATGTCTGACCAGACACCCATCAACAGTATTTTTCTCCATGAAGACGGTACGCGACTGGGCGTGGA  
GCATCTGGTGCATTGGGTACCCAGCAATCGCGCTGTTAGCGGGCCATTAAGTTCTGTCTCGGCGCGTCTG  
CGTCTGGCTGGCTGGCATAAATATCTCACTCGCAATCAAAATCAGCCGATAGCGGAACGGGAAGGCGACTGGA  
GTGCCATGTCCGGTTTTCAACAAACCATGCAATGTGTAATGAGGGCATCGTTCCCACTGCGATGCTGGTTGC  
CAACGATCAGATGGCGCTGGGCGCAATGCGCGCCATTACCGAGTCCGGGCTGCGCGTTGGTGGGATATCTC  
GGTAGTGGGATACGACGATACCGAAGACAGCTCATGTTATATCCCGCGTTAACCACCATCAAACAGGATTTTC  
GCCTGCTGGGGCAAAACCGTGGACCGCTTGTGCAACTCTCTCAGGGCCAGGCGGTGAAGGGCAATCAGCT  
GTTGCCGCTCTCACTGGTGAAGAAAAACCACCCTGGCGCCCAATACGCAAACCGCCTCTCCCGCGCGTT  
GGCCGATTATTAATGCAGCTGGCACGACAGGTTTCCCGACTGGAAAGCGGGCAGTGAAGCGCAACGCAATTA  
ATGTAAGTTAGCGCGAATTGCAAGCTGGCCGACGCGCTGGGCTACGTCTTGTGCGGTTCCGATCCCAACAA  
AGCCACGTTGTGTCTCAAATCTCTGATGTTACATTGCACAAGATAAAAAATATATCATCATGAACAATAAACTG  
TCTGCTTACATAACAGTAATACAAGGGGTGTT**ATG**AGCCATATTCAACGGGAAACGTCTTGTCTGAGGCCGC

GATTAAATTCCAACATGGATGCTGATTTATATGGGTATAAATGGGCTCGCGATAATGTCGGGCAATCAGGTGCG  
ACAATCTATCGATTGTATGGGAAGCCCGATGCGCCAGAGTTGTTTCTGAAACATGGCAAAGGTAGCGTTGCCA  
ATGATGTTACAGATGAGATGGTCAGACTAAACTGGCTGACGGAATTTATGCCTCTTCCGACCATCAAGCATTTT  
ATCCGTA CTCTGATGATGCATGGTTACTCACCCTGCGATCCCCGGGAAAACAGCATTCCAGGTATTAGAAG  
AATATCCTGATTCAGGTGAAAATATTGTTGATGCGCTGGCAGTGTTCCTGCGCCGGTTGCATTGATTCTGTT  
TGTAATTGTCCTTTAACAGCGATCGCGTATTTTCGTCTCGCTCAGGCGCAATCACGAATGAATAACGGTTTGGT  
TGATGCGAGTGATTTTGATGACGAGCGTAATGGCTGGCCTGTTGAACAAGTCTGGAAAGAAATGCATAAGCTTT  
TGCCATTCTCACC GGATT CAGTCGTCACTCATGGTGATTTCTCACTTGATAACCTTATTTTTGACGAGGGGAAAT  
TAATAGGTTGATTGATGTTGGACGAGTCGGAATCGCAGACCGATACCAGGATCTTGCCATCCTATGGAAC TG  
CCTCGGTGAGTTTTCTCCTTCATTACAGAAACGGCTTTTTCAAAAATATGGTATTGATAATCCTGATATGAATAAA  
TTGCAGTTTCATTTGATGCTCGATGAGTTTTTCTAATCAGAATTGGTTAATTGGTTGTAACACTGGCAGAGCATT  
ACGCTGACTTCTAGAACTAGCTAGAACTA

**Figure A.2 pMEK DNA sequence**

**Table A.3 Features of pMEK**

<b>Gene</b>	<b>Product</b>	<b>Coordinates</b>	<b>Protein ID</b>
orf1	ORF1; pVS1 resolvase; not required for stable maintenance	195..881	ABG33931.1
orf2	ORF2; hypothetical protein, not required for stable maintenance	878..1093	ABG33932.1
<i>staA</i>	StaA; pVS1 partitioning protein	1180..1809	ABG33933.1
<i>parG</i>	ParG; pVS1 partitioning protein	1830..2045	ABG33934.1
<i>repA</i>	RepA; pVS1 replication protein	2238..3311	ABG33935.1
<i>oriV<sub>pVS1</sub></i>	pVS1 origin of replication	3377..3571	-
<i>oriV<sub>p15A</sub></i>	p15A origin of replication	4264..5089	-
<i>oriT</i>	p15A origin of transfer	5068..5089	-
T <sub>T4</sub>	T4 transcription terminator	5148..5414	-
P6032	sequencing oligonucleotide	5402..5421	-
MCS	multiple cloning site	5416..5473	-
Tac	tac promoter, 5'UTR and RBS followed by EcoRI	compl(5468..5542)	-
<i>lac<sup>Q</sup></i>	LacIQ repressor	5977..6792	ABG33936.1
kan <sup>R</sup>	Kanamycin resistance protein	7130..7945	AAC79083.1