

London School of Hygiene & Tropical Medicine  
**DEPARTMENT OF INFECTIOUS & TROPICAL DISEASES**

**PROJECT REPORT**

**Charlotte Maplanka**

MSc: Molecular Biology of Infectious Diseases



**Analysis of the impact of TRIM5 polymorphism on  
retroviral replication**

**Supervised by Professor Greg J Towers and Dr Sam J Wilson  
Department of Infection  
University College London  
Windeyer Building  
London**

**Project Length: Long**

**For Academic Year 2006 - 2007**

**Contents**

Acknowledgements.....3

Abstract.....4

Introduction.....6

Aims and Objectives.....19

Materials and methods.....20

Results.....26

Discussion.....37

Future work .....39

References.....40

Appendix.....44

## **Acknowledgements**

Firstly, I thank Professor Greg Towers for giving me this opportunity to work in his lab and to work on a project that I have thoroughly enjoyed. I also thank him for all his advice and guidance during this period, most especially with the write-up. This has been one of my best learning experiences. A special thank you to Dr Sam Wilson for all his patience and guidance during this work, I thank him for teaching me all the techniques and for all the considerable help, support and valuable advice that he has given me with all aspects of this work. I also thank Dr Claire Pardieu for supervising the Western Blot experiment and Laura for help with some of the FACSing. Finally I thank all the members of the Towers' Lab (Sam, Ben, Claire, Laura, Shalene and Torsten) for welcoming me to the Lab and for making me feel part of the team.

## **Abstract**

This project aims to improve the SIV/rhesus macaques animal model for AIDS. TRIM5 $\alpha$  is an antiviral molecule expressed in mammals including rhesus macaques. The antiviral specificity determinant of TRIM5 $\alpha$  is within the B30.2 domain, encoded within the last exon of the TRIM5 gene. This work assessed whether B30.2 polymorphism is responsible for differences in disease progression following retroviral challenge. Exon 8 from TRIM5 was amplified by PCR and sequenced to identify the different alleles of the B30.2 domain, termed *Macaca mulatta* (Mamu) alleles. These were appended to the remainder of the TRIM5 molecule, creating TRIM5 $\alpha$  molecules with varying B30.2 domains. These were expressed in a highly permissive cell line, CRFK. A variety of green fluorescent protein (GFP) expressing retroviruses were generated within HEK 293T cells and used to infect CRFK that express different forms of TRIM5 $\alpha$ . Retroviral infection was assessed using a FACS machine, which counts GFP positive cells. This is a method of analysing differences in retroviral restriction potentials due to expression of B30.2 polymorphs. Furthermore, this project examined the dominant negative properties of the identified Mamu alleles against a strong restriction of HIV-1, Mamu1. Cells were protected from infection with FIV, HIV-1, HIV-2 and EIAV by some of the Mamu alleles tested, except Mamu7. In contrast, SIV, MLV-B and MLV-N were not restricted by any of the Mamu alleles tested in this study. Interestingly Mamu4 and Mamu5 protected cells from HIV-1, FIV and EIAV infection but not from HIV-2 infection. These alleles therefore appear to encode functional restriction factors with different antiretroviral specificities. Mamu7, a truncated allele showed the least restricting properties of all tested alleles. However, co-expression of

Mamu7 with the wildtype TRIM5 $\alpha$  allele was found to slightly abrogate restriction in a dominant negative manner following challenge with HIV-1 and HIV-2. In addition, Mamu4 and 5 exerted a mild dominant negative effect following HIV-2 infection, consistent with their inability to restrict HIV-2 when expressed alone.

## **Introduction**

The identification of an animal model for AIDS vaccine studies continues to present a significant challenge. One important facet of an ideal animal model is that it has to show a reproducible disease progression in an infected animal. Specifically, it is useful to know if the reason animals do not become sick following retroviral challenge is due to their genotype or due to vaccination. It has become apparent that some rhesus macaques are resistant to disease after challenge with SIVmac and do not become ill. Clearly such animals are not useful AIDS animal models. There is a need to identify the factors that contribute to this resistance before an animal is enrolled for vaccine trials.

Recent studies in infectious disease research have revealed the existence of antiviral cellular factors that have evolved within mammals due to selection pressure from pathogenic viruses. These are termed restriction factors and they present an important and very challenging area of this field. In function, they contribute to an innate immune barrier against a range of viruses (1, 2). Amongst the well known restriction factors is the tripartite motif protein (TRIM) family, some of which have been found to have antiviral properties. One member of the family (TRIM5 $\alpha$ ) is antagonistic to the replication of both lentiviruses and gammaretroviruses in a species-specific manner. For example, infection with the human immunodeficiency virus (HIV-1) is potently restricted by rhesus macaques TRIM5 $\alpha$ , but conversely, human TRIM5 $\alpha$  does not restrict HIV-1 infection (3, 4). TRIM5 $\alpha$  was discovered in 2004 following the screening of a cDNA library from rhesus macaques to identify cDNAs with antiviral activity against HIV-1 (2). TRIM5 $\alpha$  act in the cytoplasm of the host cell (4, 5) and the

expression of this protein is induced by interferon via the interferon regulatory factor 3 (IRF3) binding the TRIM5 promoter. IRF3 is a transcription factor that mediates a specific gene expression program involved in the innate antiviral response (6).

The TRIM5 gene is alternatively spliced, leading to a number of isoforms of the protein product (*figure 1*) each of which is shorter from the C-terminus. TRIM5 $\gamma$  and TRIM5 $\delta$ , both lack the B30.2 domain, a ret finger-like protein (RFP) domain consisting of the combination of a PRY and SPRY (PRY-SPRY) domain on their carboxy-terminal (5, 7, 8). TRIM5 $\alpha$  is the longest isoform (~493 amino acid residues with a molecular mass of 54 to 56 kDa per monomer in rhesus macaques) (5, 9, 10) and the only isoform that encodes a B30.2 domain. The B30.2 domain is known to interact directly with the incoming viral capsid. Additionally, it is the only isoform with antiviral activity illustrating the importance of the B30.2 domain in this regard (1, 4, 7). Rhesus TRIM5 $\alpha$  specifically binds the HIV-1 capsid in an interaction that is dependent on the B30.2 domain (9). The shorter isoforms, Rhesus TRIM5 $\gamma$  and TRIM5 $\delta$  exert a dominant negative effect that represses restriction, by the wildtype TRIM5 $\alpha$ , rescuing restricted infectivity following their over-expression (1, 2, 11). This is thought to occur through the titration of viral binding B30.2 domain due to heteromultimers formed by TRIM5 $\gamma$  and TRIM5 $\delta$  via the coiled coil (2). The B30.2 domain contains three or four variable regions (V1, V2, V3 and V4) which vary between different TRIM5 B30.2 domains and are thought to have been subjected to very strong positive selection pressure from retroviruses. In this regard, it is vital to mention that the rhesus macaques TRIM5 gene has numerous polymorphisms that are found in the variable loops, (2). Importantly,

TRIM5 $\alpha$  variable regions also influence antiviral specificity. Studies on the binding specificities of TRIM21 have revealed two substrate binding surfaces one of which is found in the PRY (V1) and another in the SPRY (V2-V3) loops and this is also thought to be the case for TRIM5 $\alpha$  (2). This is also supported by reports that the SPRY domain recognises an intricate structure that is only found in the core of susceptible viruses (12).

B30.2 is found on a single exon (8) of the TRIM5 gene (figure 1A and 1B) (8, 13, 14). Its contribution to retroviral restriction and disease progression following retroviral infections constitute the basis of this investigation.

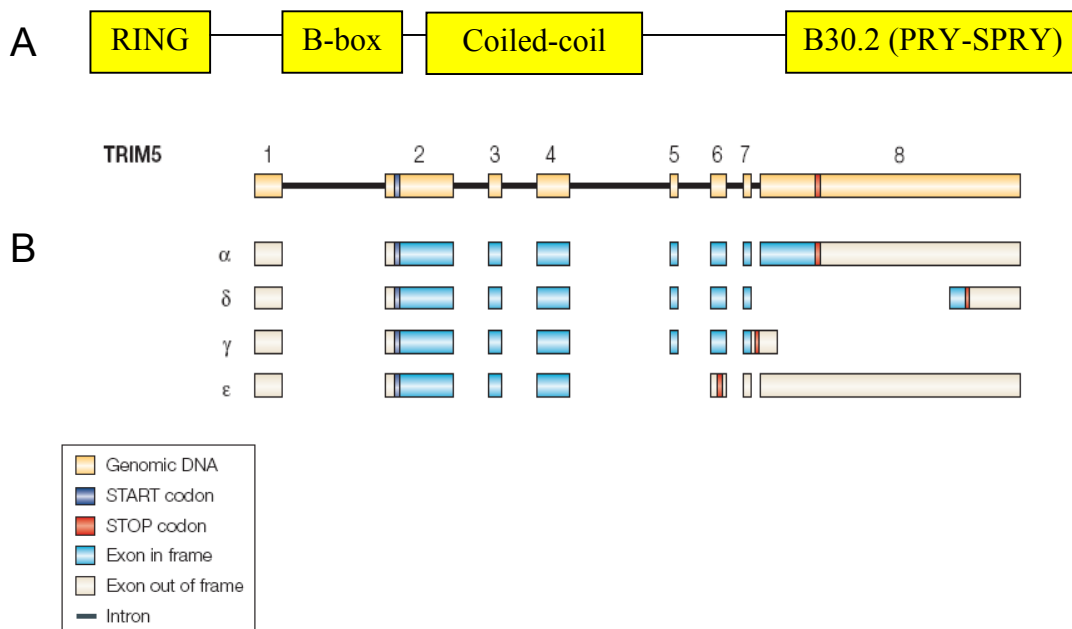

**Fig 1A and B: The domain structure of TRIM5.** An illustration of TRIM5 $\alpha$  showing the domain structure of TRIM5 $\alpha$  proteins (A) and the eight exons in different TRIM5 isoforms, (B) (14) of interest in this work is TRIM5 $\alpha$  exon 8, the B30.2 domain.



TRIMs are also called RBCC proteins, constituting a RING (really interesting new gene), domain that encodes two atypical zinc fingers and is involved in specific protein-protein interactions. Numerous RING domains comprise E3 ubiquitin ligase activity; indeed a RING dependent autoubiquitylation can be mediated by TRIM5 *in vitro* (2, 15). Another report states that a disruption of this domain results in the mislocalisation of TRIM5 $\alpha_{rh}$  and a reduction in the cytosolic levels of the protein in comparison to the wildtype protein. Furthermore it has been shown that RING mutants retain their retroviral inhibition abilities (5). TRIMs also consist of one of either 2 types of B boxes, B-box1 or B-box2; these domains have a zinc-binding motif and are assumed to be involved in protein-protein interactions. TRIM5 has a B-box 2 (2, 9). B-box 2 also seems to be necessary for efficient retroviral inhibition. Additionally, B-box 2 mutants have been reported to associate with the wildtype TRIM5 $\alpha$ , interfering with its antiretroviral activity in a dominant negative way (5). TRIMs also encode a coiled coil domain, involved in the homo- and hetero-multimerisation of the whole protein and mediates trimerisation; (2, 9) some TRIMs also have a B30.2 which also functions in protein-to-protein interactions (7, 16-18). A defining characteristic for TRIM5 $\alpha$  is that it is the longest and the only TRIM5 with a B30.2 domain; additionally it is the only one with an antiretroviral activity (1, 7, 16, 17). This has highlighted that the B30.2 domain is the restriction specificity determinant, essential for viral restriction (16, 17, 19). Crucially, this domain is recruited to incoming viral cores and is necessary for capsid recognition and binding (2, 17). TRIM5 molecules lacking the PRY-SPRY domain do not have antiretroviral activity (17). Furthermore, there is evidence that the ability of TRIM5 $\alpha$  to bind a viral capsid is not adequate for complete viral restriction (5).

TRIM5 $\alpha$  mutants lacking the RING and/or B-box 2 domains have been shown to bind and form complexes with HIV-1 capsid-nucleocapsid but were partially or completely unable to effect viral restriction, suggesting that the amino-terminal elements of the restriction factor function as effector domains (5, 9).

Both human and monkey TRIM5 $\alpha$  derivatives have been shown to block the entry of a group of retroviruses, (16, 17, 20, 21) with HIV-1 strongly inhibited by rhesus TRIM5 $\alpha$  (17, 21). In humans, HIV-1 has evolved and adapted to evade human TRIM5 $\alpha$  activity (8, 22). TRIM5 $\alpha$  is a dominant antiviral factor; illustrated by the fact that the block to infection could be saturated or abrogated by elevated concentrations of retroviral cores (4). Importantly, retroviral capsid structures are conserved with capsid hexamers found in both lentiviruses and gamma retroviruses and therefore TRIMs are presumed to recognise a conserved capsid surface (2, 12). However, a single point mutation can result in a virus that escapes restriction and thus the effectiveness of TRIM5 in viral restriction continues to puzzle researchers in this field; this is in light of the fact that minor changes in the viral capsid can rescue infectivity and also that retroviral capsid sequences are rather plastic (2). Summarily, susceptibility to TRIM5 $\alpha$  restriction is also largely determined by viral capsid sequences and the determinants of susceptibility map to the capsid protein (9).

Upon cell entry retroviruses sequentially undergo a series of steps that serve to establish productive infection; these viral steps include viral core uncoating, reverse transcription, trafficking to and nuclear entry, and viral DNA integration into the host genome (4).

TRIMs are constitutively expressed in many tissues (21, 22) and are induced by interferons, highlighting their innate immune role (16). TRIM5 $\alpha$  forms a trimer that interacts with the hexameric retroviral capsids; this molecule is ubiquitinated within cells and is rapidly turned over by the proteasome in a RING domain dependent manner, this implies that the process might be mediated by autoubiquitination (2, 10). Although the complete mechanism of action of TRIM5 $\alpha$  has not yet been fully characterized, it is thought that upon viral binding and fusion with the target cell, TRIM5 $\alpha$  interferes with the early uncoating steps required to liberate viral nucleic acids into the cytoplasm and that rapid turnover of both TRIM5 $\alpha$  and TRIM5 $\alpha$ -viral complexes results in early infection blockade, prior to viral reverse transcription (2, 5, 23). Forshey *et al.* suggest that the process of capsid uncoating is tightly regulated therefore uncoating that is too rapid or too slow might in fact compromise infectivity of a virus (24). Surprisingly, proteasome inhibition has been found to be unable to rescue infectivity and has no effect on the levels of TRIM5 $\alpha$ ; (15, 25, 26) also, proteasome independent degradation of capsids by TRIM5 $\alpha$  has been reported (15, 25) suggesting that viral degradation via proteasomes is not the key element in TRIM5 $\alpha$  restriction. Additionally, other studies report unaltered levels of total cytoplasmic concentrations of viral capsid following the introduction of TRIM5 $\alpha$  into cells, suggesting that the process does not promote capsid degradation (9). It remains unclear how TRIM5 $\alpha$  induces viral restriction but it is assumed that through coating the viral core with multivalent complexes the molecule induces debilitating disruptions to vital viral processes such as the rearrangement/uncoating and/or trafficking essential for migration to the nucleus for integration (2). Rapid uncoating of viral cores might also be involved and this has been

observed in the case of HIV-1, (24) a virus that is restricted by TRIM5 $\alpha_{rh}$ . In summary, it is supposed that TRIM5 $\alpha$  restriction involves the prevention of capsid uncoating, accelerated uncoating, or the destruction of the viral capsid (9). These activities may not be mutually exclusive.

High-affinity binding of the viral capsid is mediated by the B30.2 domain via a canonical binding interface of six antibody-like Variable Light chains (VLs) (27). An observation that very little viral DNA is synthesised in a majority of TRIM5 $\alpha$ -restricted virions signifies that viral blockade occurs during the early stages of cell infection. This also implies that interaction between restriction factors and the incoming virion occur early after cell entry (28-30). The fate of a restricted virion is possibly dependent on factors such as the type of virus, particular TRIM5, viral dosage and the concentration of TRIM5 $\alpha$  expression together with other cellular constituents. Table 1 lists some of the possible fates of restricted viruses.

**Table 1: The three likely fates for a restricted virion**

A restricted virion may:

1. Be degraded by the proteasome
2. Inappropriately uncoat
3. Remain intact and make DNA but not have access to the nucleus

In summary, The B30.2 domain is essential for retroviral capsid binding and restriction (12) which protects against infection and subsequent disease progression following viral challenge.

#### Brief look into dominant negative effects

The term dominant-negative describes a gene product or protein that exhibits adverse effects on the normal gene product, in this case wild type TRIM5 $\alpha$  within the same cell. Dominant negative processes normally occur if the mutant product retains the ability to interact with the same substances as the wildtype protein. The mutant product exerts a negative effect, preventing and exerting a negative impact on the normal functions of the wild type protein product. The process of dominant negative can be illustrated in proteins such as TRIM5 $\alpha$  that multimerise where one part of the protein complex is mutant in some functional aspects of the trimer, (such as the lack of a B30.2 domain resulting in lack of antiviral properties) but can still form a multimer it can have a dominant effect on the wildtype parts of the complex and a negative effect if the mutation prevents the complex from fulfilling its regular functions, retroviral restriction (31). Consequently, the gene encoding the mutant monomer component of the trimer is called a dominant negative protein.

TRIM5 $\gamma$  and TRIM5 $\delta$  are the shorter isoforms of TRIM5 encoding a C-terminal that differs from wildtype TRIM5 $\alpha$ . When expressed simultaneously with a wildtype TRIM5 $\alpha$  the two isoforms exert a dominant negative effect that represses HIV-1 and MLV-N restriction, respectively increasing permissivity of cells to viral infection and rescuing restricted infectivity (1, 2, 11). Additionally, a functionally defective TRIM5 $\alpha$

mutant with the RING and B-box deleted has been found to hetrotrimerise with the wild type molecule exerting a dominant negative activity on retrovirus restriction (5, 10)

### The AIDS model

Rhesus macaques TRIM5 $\alpha$  (TRIM5 $\alpha_{rh}$ ) restricts HIV in a species-specific manner with the B30.2 domain mainly responsible for the observed anti-HIV-1 potency (21, 32, 33). Consequently, this system cannot be used as a model for AIDS in vaccine studies. The best animal model therefore involves infecting rhesus macaques with a SIVmac derivative, a virus that is closely related to HIV-1 and has similar pathogenesis in macaques to HIV-1 in humans. SIVmac is known to be weakly restricted by TRIM5 $\alpha_{rh}$  (5). SIVmac infection in rhesus macaques also has similar characteristics to HIV-1 infections in humans including progression to AIDS (30). However, it has also been found that individual rhesus macaques are not equally permissive to SIVmac infection and that not all animals develop disease after viral challenge (3, 30). This demonstrates differing susceptibility within a species (3) and raise the question as to whether TRIM5 polymorphism may be responsible for these observations.

Very relevant to the proposed aims of this work are the recent findings by Newman *et al.* that identified six different *Macaca mulatta* alleles, designated Mamu1-6 that highlight polymorphism within the B30.2 domain in two divergent lineages of Old World monkeys (3). In this regard, it is interesting to investigate whether more Mamu alleles are in existence and can be identified. Additionally, polymorphic B30.2 domains

may cause particular TRIM5 molecules to restrict SIVmac more strongly or weakly. Polymorphism in both the length and encoded amino acids within the B30.2 domain have been highlighted and seen in all three variable regions of the B30.2 domain (1, 13, 33). Other studies have highlighted that amino acid positions, specifically the presence of certain amino acids at particular sites (in particular, the ones lining the binding surface) of the B30.2 domain is central to viral restriction (8, 13, 34). These amino acids have also been shown to be highly variable which implies that the particular domains constitute the protein-interacting modules (34).

Taken together, the above findings highlight that inter-species variation within the B30.2 domain affects retroviral restriction specificity within primates. Therefore, at present, it appears that the remaining unanswered question is whether intra-species TRIM5 $\alpha$  polymorphism is indeed partially responsible for the observed differences in permissivity and dissimilar disease progression following retroviral challenges in animals enrolled in vaccine trials, which is the basis of this study.

#### Background knowledge to this work

Unpublished findings by S. Wilson from Greg Towers' Lab have identified 2 further alleles, designated Mamu-7 and 8 (and another allele presently called FDFS) in addition to Mamu1, 3, 4 and 5, previously described by Newman *et al* (3). These were identified following the sequencing of the B30.2 domain from at least 60 Chinese and Indian rhesus macaques, enrolled in vaccination studies. Mamu7 encodes a truncated B30.2

domain that has a different B30.2 domain with 8 non-synonymous single nucleotide polymorphisms in addition to an insertion/deletion; Mamu8 is a full B30.2 domain. It should be noted that Mamu2 and Mamu6 were not identified in the study by S. Wilson. Alleles Mamu1, 3, 4 and 5 were identified in both Indian and Chinese rhesus macaques while Mamu7 was only found in Indian macaques (*Table 2*) the allelic frequency for Mamu8 and FDFS is not shown in this table. It is not clear whether Mamu8 is a true polymorphism or a mutation because it was only identified in one individual (excluded from *Table 2*)

**Table 2: Mamu allelic frequency in rhesus macaques used in this study** (reproduced with permission from S. Wilson)

<i>Macaca mulatta</i> origin	Allelic frequency				
	Mamu1	Mamu3	Mamu4	Mamu5	Mamu7
Indian	12/62 (19.35%)	19/62 (30.65%)	7/62 (11.29%)	8/62 (12.9%)	16/62 (25.81%)
Chinese	4/76 (5.26%)	37/76 (48.68%)	25/76 (32.89%)	10/76 (13.16%)	0/76 (0%)

All of the identified Mamu alleles were also found to have unique B30.2 domain sequences, (*Fig 2*) the discovery of these variations within the sequences also indicated possibilities of differences in retroviral restriction properties among the alleles; the FDFS B30.2 domain sequence is not shown. The identified B30.2 domains were expressed in CRFK and FRHK cells (*see material and methods section*) and their



restriction properties tested against a range of retroviruses including HIV-1. TRIM5 $\alpha$  molecules with Mamu 1, 3, 4, 5 and 8 B30.2 domains were found to restrict infection by HIV-1, FIV and EIAV, while the TRIM5 $\alpha$  with Mamu 4 and 5 B30.2 domains were found to be unable to recognize HIV-2 additionally, none of the identified alleles was reported to have antiviral properties against SIV. Thus an observation that functional TRIM5 $\alpha$  alleles exhibit differences in antiretroviral specificities.

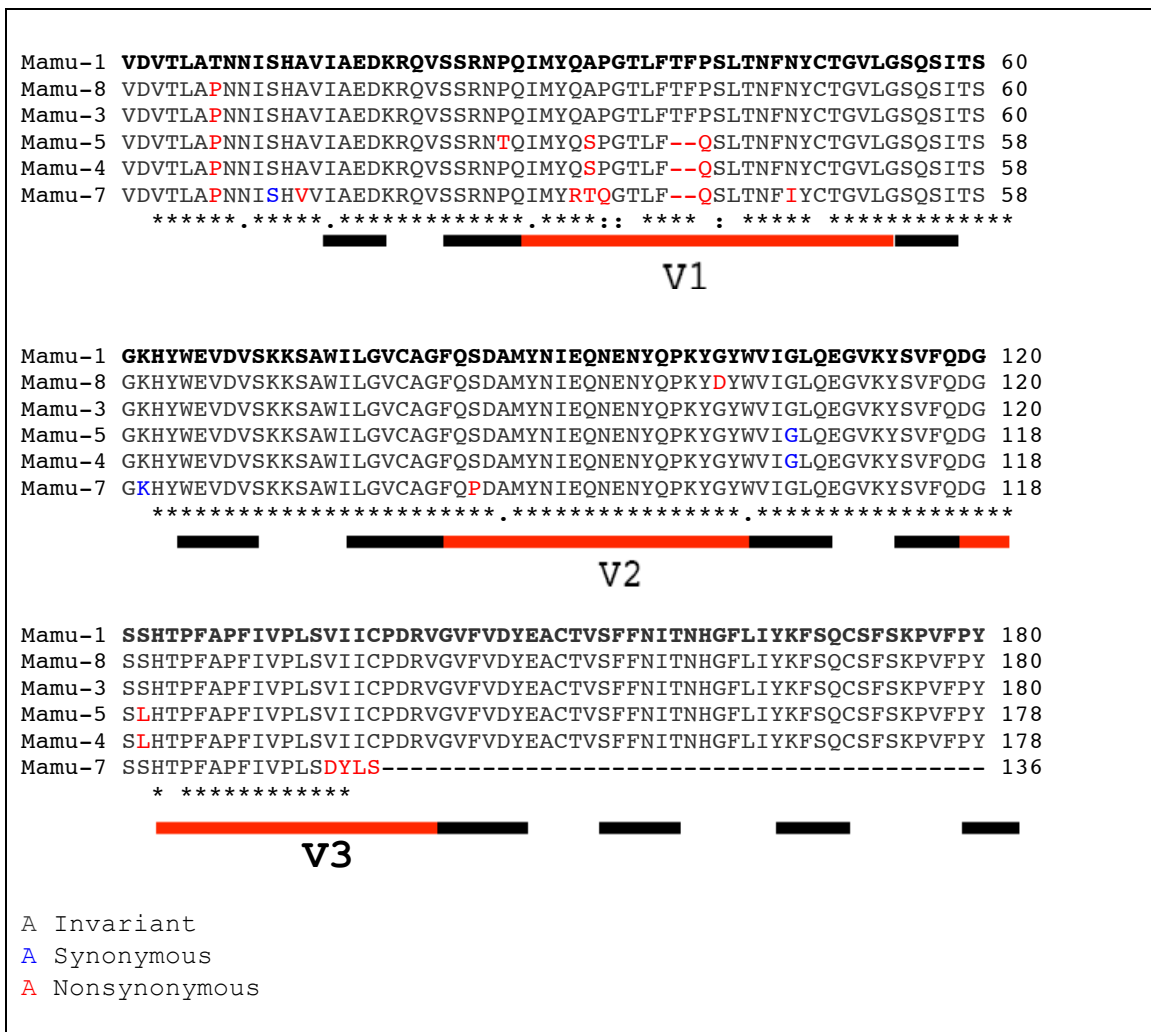

**Fig 2: Sequences of the rhesus macaques B30.2 domains used in this study.** The rhesus macaques amino acid sequences of the Mamu alleles used in this study. Mutations and deletions are shown in red, asterisks indicate conserved regions and gaps indicate deletions. (reproduced with permission from S. Wilson)

This project revisits the experimental work by S. Wilson; therefore this work is set to test the restriction properties of the identified various B30.2 domains, and a synthetic truncated Mamu1 (FDFS), against a range of retroviruses. Furthermore, the work will also test the dominant negative properties of the identified Mamu alleles against HIV-1 and HIV-2. In conclusion, this project sets out to improve the SIV/rhesus macaques animal model for AIDS. This will be undertaken by closely examining whether polymorphism within the B30.2 antiviral determinant of TRIM5 is indeed partially responsible for the differences seen in disease progression following retroviral challenge. Therefore this work seeks to establish if particular alleles are in fact associated with better or worse disease progression in rhesus macaques challenged with SIVmac and a range of its derivatives.

## **Aims and objectives**

The aim of this work is to improve the SIV/rhesus macaques animal model for AIDS by examining the contribution of TRIM5 $\alpha$  polymorphism to disease progression. We retrospectively sequenced the B30.2 domain, which encodes the antiviral specificity determinant of TRIM5 $\alpha$ , from at least 60 Indian and Chinese Rhesus macaques enrolled in vaccine studies. This was done to establish if particular alleles are associated with better or worse disease progression following retroviral infection. An *in vitro* assessment of the ability of the identified alleles to restrict infection by a range of retroviruses was undertaken using established techniques; additionally this project also assessed the dominant negative properties of the identified TRIM5 $\alpha$  alleles against HIV-1 and HIV-2. The overall objective of this work was to associate differences in susceptibility to retroviral infections with particular TRIM5 $\alpha$  sequences, focusing on the B30.2 domain antiviral determinant.

## **Materials and methods**

### Cell lines

A highly permissive feline cell line, CRFK cell line was propagated in Dulbecco's Modified Eagle Medium (DMEM), supplied by GIBCO supplemented with 10% Fetal Calf Serum (FCS) and 1% penicillin and streptomycin at 37°C, 5% CO<sub>2</sub>. Once confluent, the cells were passaged at a dilution factor of 1:4. Human kidney cell line, HEK 293T cells were also grown in DMEM with 15% FCS and 1% penicillin and streptomycin and incubated at 37°C, 10% CO<sub>2</sub>. FRHK4 cells, expressing HA-tagged TRIM5 $\alpha$  rhesus macaques cells (a generous gift from S. Wilson) were treated as above for CRFK cells. FRHK4 cells are rhesus macaques cells that endogenously express TRIM5 $\alpha$ .

### Bacterial Transformation

Plasmids listed in Table 3 (generous gifts from S. Wilson and T. Schaller) were introduced into *Escherichia coli* (*E. coli*) cells strain HB101 using heat shock of chemically competent *E.coli* cells (a generous gift from L. Ylinen) and plated on Ampicillin-containing agar plates that were incubated overnight at 37°C. A single colony of the transformed *E.coli* was picked and used to inoculate a flask containing 500ml Luria-Bertani liquid broth medium and 1% Ampicillin. The recombinant plasmid was purified using the Qiagen® Midiprep method in accordance with the manufacturer's instructions and the yield was determined using nanodrop spectrophotometry.

**Table 3: Plasmids and expression vectors used in this study** all plasmids were generated as previously described (30, 35-43).

1. pSIV GFP
2. pSIV 3+ (SIVmac gag-pol expresser)
3. pCIG3N (MLV-N gag-pol expresser)
4. pCIG3B (MLV-B gag-pol expresser)
5. MLV-N GFP
6. MLV-B GFP
7. pONY3.1 (EIAV gag-pol expresser)
8. pONY4.0Z (pEIAV GFP)
9. pHR'SINcSGW (HIV-1 GFP) (a generous gift from A Thrasher)
10. p8.91 (HIV-1 Gag-pol) (generous gift from D. Trono)
11. pSVRΔNBPuroΔH (HIV-2 vector encoding GFP)
12. pSVRΔNB (HIV-2 RODA gag-pol expression vector)
13. VSV-G expression vector, pMDG (generous gift from D. Trono)
14. MLV viral vector called pEXN (which contains a G418 selectable marker, and is under the control of the cytomegalovirus (CMV) IE promoter) (generous gift from P. Bieniasz)

#### Transient transfection (generating pseudotyped retroviral vectors)

VSV-G pseudotyped GFP expressing retroviral vectors were generated by transfecting a 10-cm plate of HEK 293T cells with three plasmids (*Fig 3A*) namely 1μg gag-pol, 1.5μg vector genome/GFP and 1μg VSV-G expression vectors using Fugene-6 (Roche). The introduction of the three plasmids into HEK 293T cells resulted in the formation of virions (*Fig 3B*) that are released into the supernatant and collected at 48 and 72 hours after transfection, filtered, stored at -80°C and subsequently used to infect the CRFK cell line.  $1 \times 10^5$  cells per well (plated in a six-well plate) were infected with 3-fold serially diluted virus. Infected cells were incubated for 48 hours and infectivity was determined by measuring GFP expressing cells using a fluorescence-activated cell sorter (FACS) and the percentage infected cells was plotted against the input dose of each

virus, measured in microlitres per millilitre. The titre was determined by calculating the number of infected cells per 1ml of virus supernatant. It is assumed that  $2 \times 10^5$  cells are present in a plate on the day of transfection.

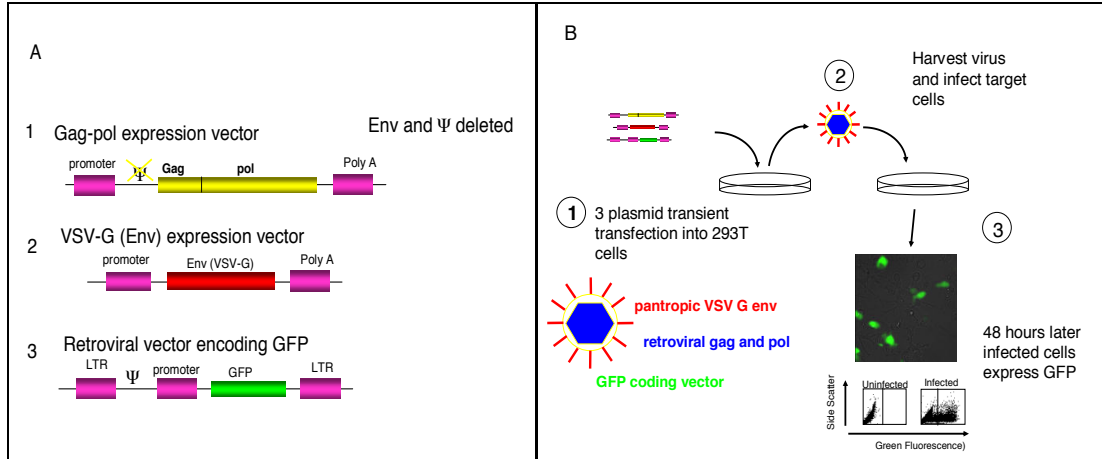

**Fig 3: Expression vectors used to express viral genes, transfection and an infectivity assay.** Expression vectors used in transient transfection of 293T cells (A). Plasmids encoding gag-pol expression vectors and GFP are pseudotyped with a VSV-G envelope from vesicular stomatitis virus, (the VSV-G envelope glycoprotein allows efficient entry into a wide range of vertebrate cells) and transfected into 293T cells. The supernatant containing virions is collected after 48 and 72 hours, filtered and used to infect CRFK cells and infectivity is assayed by FACS (B). N.B all retroviral coding sequence has been removed. (reproduced with permission from Greg Towers)

### TRIM5 expression in CRFK

HA-tagged TRIM5 $\alpha$  molecules were expressed in CRFK cells using the MLV viral vector, pEXN (which contains a G418 selectable marker). An empty vector was also introduced into CRFK cells and this functioned as a negative control. HA-tagged TRIM5 $\alpha$  expressing cells and those containing empty vectors (a generous gift from S. Wilson) were kept frozen in liquid nitrogen and resuscitated by placing in a water bath at 37°C. Once thawed the cells were re-suspended in fresh DMEM medium and incubated for 48 hours to encourage propagation. Confluent cells were plated on six

well plates at  $1 \times 10^5$  cells per well, incubated overnight and challenged with 3-fold serial dilutions of GFP expressing viruses in the presence of polybrene which enhances cell infection.

#### FACS analysis

After 48 hours, cells were washed in phosphate-buffer saline (PBS), trypsinised and transferred into FACS tubes, fixed with 2% formaldehyde and cell infection was measured using FACS. Infectious titres were calculated and used to plot bar charts. These values were generated using 3 different virus doses and error bars are the standard deviation of the mean of these titres. Thus we were able to compare viral titres following the expression of TRIM5 $\alpha$ .

#### Dominant negative assays

Frozen FRHK4 were thawed and propagated as above for CRFK cells. Confluent cells were plated on six well plates at  $1 \times 10^5$  cells per well, incubated overnight, different doses of TRIM34 and all TRIM5 $\alpha$  alleles used in this study with the exception of FDFS (in viral expression vectors) were added to each plate, mixed by shaking for 5 minutes and spinoculated in a centrifuge at 500rpm for 2 hours to sediment the virus, cells were then incubated at overnight 37°C, 5% CO<sub>2</sub> to allow for infection. Cells were then distributed in duplicate and one plate of each of the expressed TRIM5 alleles and TRIM34 was challenged with serial dilutions of GFP expressing HIV-1 or HIV-2 viruses in the presence of polybrene. Cells in parallel plates were lysed to extract

protein which was transferred into 1.5ml tubes and its expression assessed by western blot.

### Western blot

Cells were re-suspended in loading buffer (*see appendix*), sonicated for 10 seconds and centrifuged at 1200rpm for 10 minutes. The supernatant was transferred into clean tubes and protein denatured by boiling for 5 minutes. 15µl of each sample was loaded onto a 12.5% SDS-PAGE gel (*see appendix*) and separated by running the gel at 150 volts for 60 minutes. Protein was then transferred to Hybond-P (GE Healthcare UK limited) (activated by immersing in methanol and transfer buffer for a few seconds) using a semi-dry transfer method. Transfer was performed according to manufacturer's instructions.

To prevent non-specific binding, membranes were incubated in 10ml of blocking solution (TBS-T + 5% dried milk powder) for one hour at room temperature. Membranes were then probed with an anti HA tag Ab, HA.11 Monoclonal Antibody (Covance, UK [Cat nb MMS-101P]) directed at the HA tag at a concentration of 1:4000 in 1% milk TBS-T, for 3 hours at room temperature. The membranes were extensively washed with TBS-T buffer to remove unbound molecules, a secondary antibody, anti-mouse IgG horseradish peroxidase linked whole antibody (from sheep) (GE Healthcare, UK [cat nb NA931V]) was used to bind the primary antibody for 1 hour at room temperature and then washed as before. The ECL Plus Western Blot detection system was used in accordance with the manufacturer's instructions. Gels were exposed to X-



ray films, amersham hyperfilm (ECL, GE Healthcare UK limited) for 5 minutes to detect bands.

## Results

TRIM5 $\alpha$  was first described in 2004 and has been previously shown to possess antiviral activity against retroviruses in a species-specific manner. For example human TRIM5 $\alpha$  cannot restrict HIV-1. Conversely, rhesus macaques TRIM5 $\alpha$  potently restricts HIV-1 (3, 4). We asked if there might also be specificity variation within a species as this might have an important effect on vaccine trials using rhesus macaques enrolled as AIDS animal models. The B30.2 domain of TRIM5 $\alpha$  is known to encode the antiviral specificity and the discovery by Newman *et al.* that polymorphism exists within this domain highlighted the possibility of intra-species specific retroviral restriction. Once different alleles of the B30.2 domain, namely the *Macaca mulatta* (Mamu) alleles were sequenced and identified we aimed to test their restriction properties against a range of retroviruses. Initially the identified Mamu alleles were appended to the remainder of the TRIM5 molecule, HA-tagged and successfully expressed in a highly permissive feline cell line, CRFK.

### Transient Transfections (generating pseudotyped retroviral vectors)

A range of VSV-G pseudotyped retroviral vectors expressing GFP as a reporter protein were generated by the transient transfection of HEK 293T cells. Once these were harvested their infectious titres were assessed by infecting CRFK cells with each virus. Infected cells were incubated for 48 hours at 37°C 5% CO<sub>2</sub>. The percentage of infection was determined by FACS analysis which counts GFP positive cells from which the viral titres were calculated and viral infectious titres were determined by calculating the number of infected cells per  $\mu$ l extrapolated to 1ml (*Fig 4 and Table 4*). Initial stocks of

SIVmac and FIV were found to have titres that were lower than expected therefore another batch was made using a fresh culture of HEK 293T cells and a significant improvement on titres of both viral stocks was achieved but more so for SIVmac which showed at least a 10-fold increase.

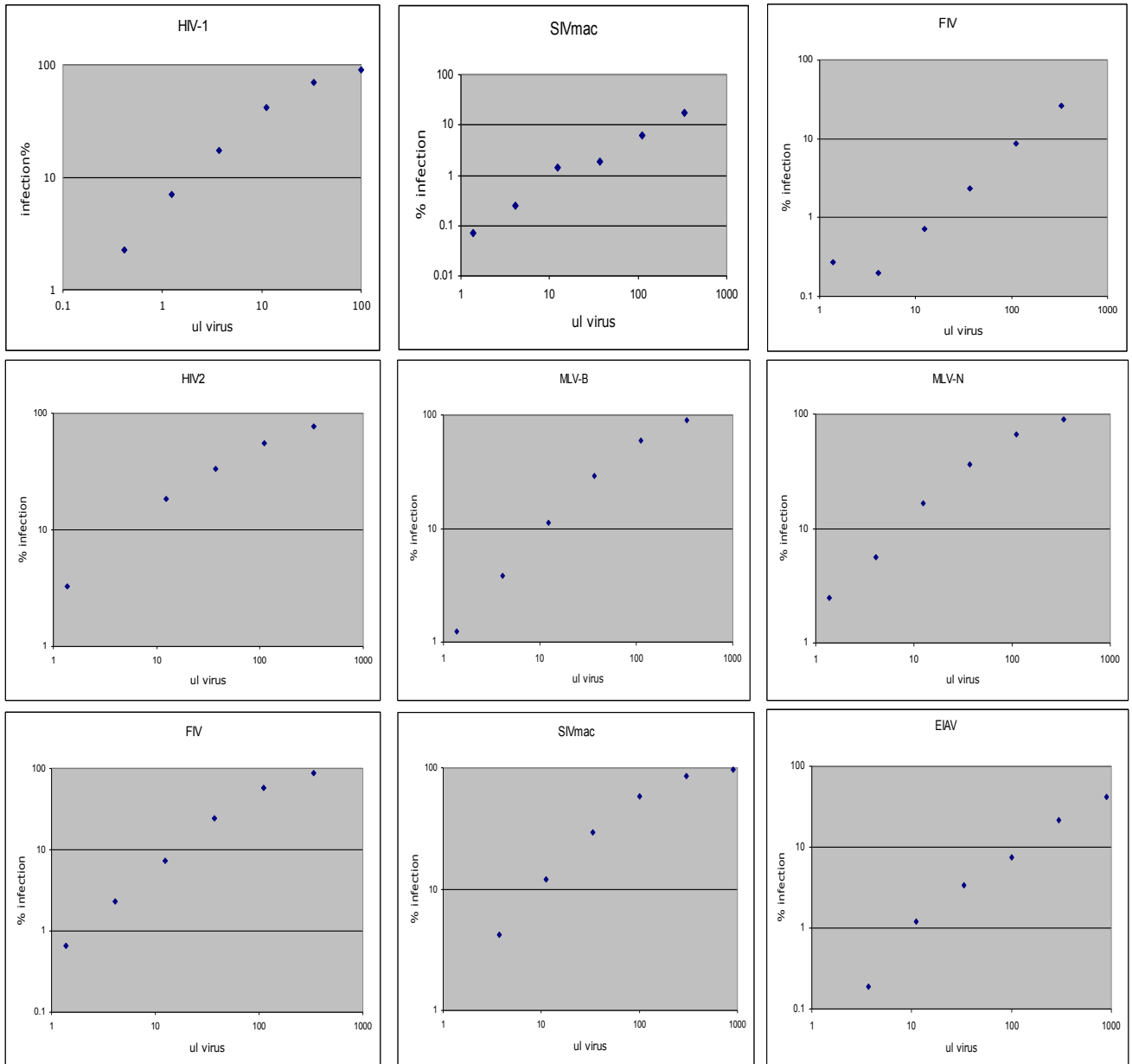

**Fig 4: Log plots showing infectious titres (determined by calculating the number of infected cells per  $\mu$ l extrapolated to 1ml) of retroviruses used in this study.**

**Table 4: Titres of GFP expressing retroviruses used this study**

<b>Virus Name</b>	<b>Titre infectious units per millilitre (iu/ml)</b>
HIV-1	$1.1 \times 10^7$
SIVmac (initial stock)	$1.11 \times 10^5$
FIV (initial stock)	$1.55 \times 10^5$
HIV-2	$2.98 \times 10^6$
MLV-B	$1.81 \times 10^6$
MLV-N	$2.71 \times 10^6$
FIV	$1.19 \times 10^6$
SIVmac	$2.16 \times 10^6$
EIAV	$1.51 \times 10^5$

#### Restriction properties of various B30.2 alleles of TRIM5 $\alpha$

We investigated whether polymorphism within the B30.2 domain of TRIM5 $\alpha_{rh}$  led to differential restriction of a range of retroviruses. G418 selected ‘bulk’ populations of CRFK cells expressing Mamu alleles, Mamu 1, 3, 4, 5, 7, 8 or FDFS appended to the RBCC domains of Mamu1 were infected with serial dilutions of the GFP expressing viruses (*Figs 5*) and incubated for 48 hours at 37°C. CRFKs transduced with an empty vector (EXN) and untransduced CRFKs both served as negative controls. The empty vector illustrated the effects of expressing the vector alone on viral restriction while the untransduced cells served as a baseline for the infectivity of each virus. The percentage of infected cells was assessed by FACS and plotted in infectious units per millilitre as before. Bar charts were generated using 3 different virus doses. The error bars are the standard deviation from the mean of these titres and these allowed the comparison of viral titres following the expression of TRIM5 $\alpha$  encoding Mamu 1, 3, 4, 5, 7, 8 and FDFS B30.2 domains in CRFK cells and the EXN expressing and untransduced CRFKs (*Fig 5*).

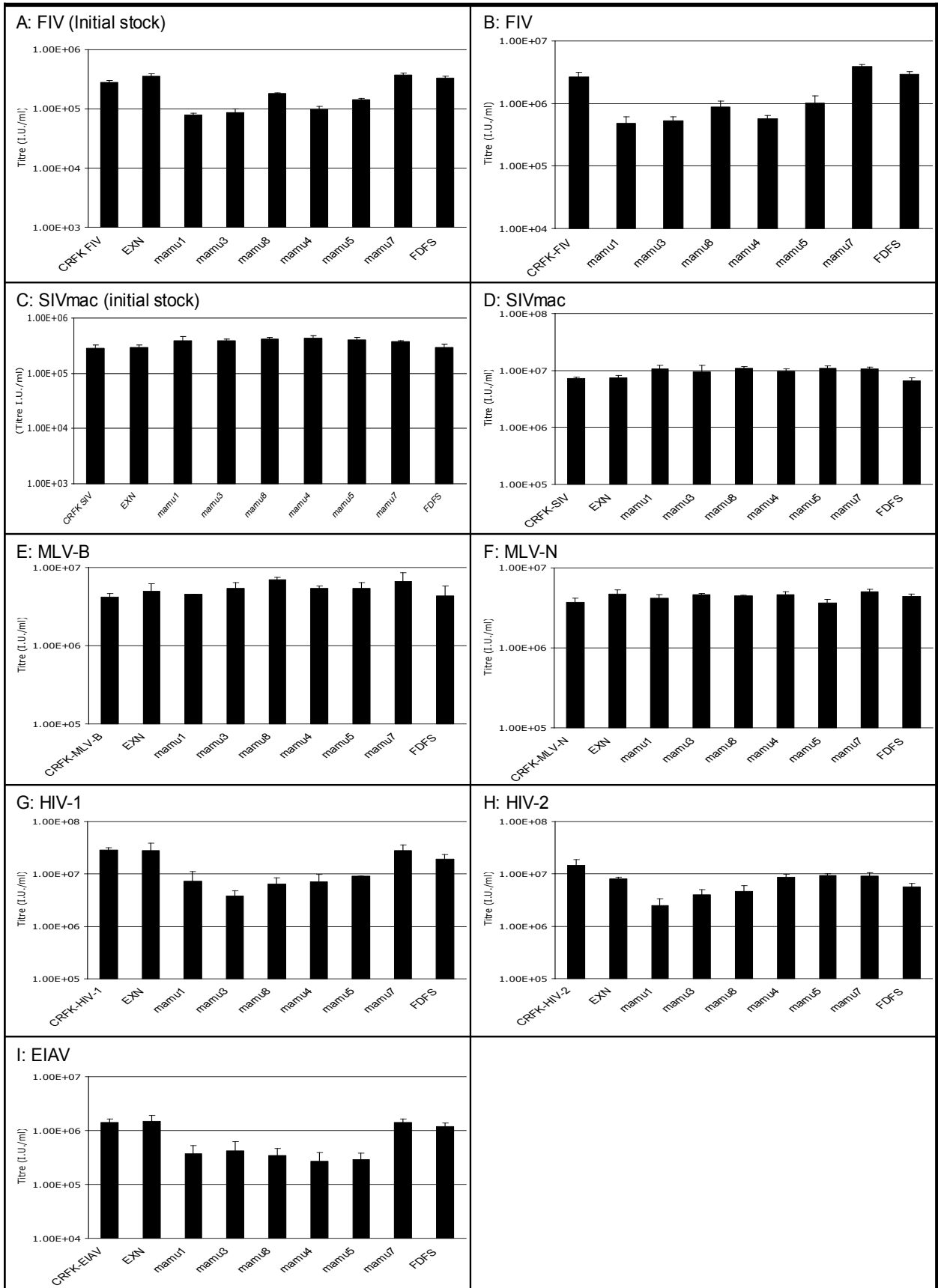

**Fig 5: Effects of polymorphism within TRIM5 $\alpha_{rh}$  B30.2 domains on retroviral infection.** CRFK cells expressing TRIM5 $\alpha$  molecules encoding various Mamu alleles and control CRFK cells transduced with an empty vector, EXN or untransduced were incubated with the indicated recombinant GFP expressing retroviruses. Bar charts show the infectious titres of each virus determined by counting the number of GFP positive cells.

**FIV** infection was moderately restricted by Mamu 1, 3, 8, 4 and 5 alleles. Mamu 1 and 3 alleles were more potent at suppressing this virus by up to 8-fold in comparison to the other alleles (up to 4-fold) while Mamu 7 and FDFS did not protect cells from infection with this virus (*Fig 5A and B*). This same trend was observed using either of the independently prepared viral stocks (*Table 4*).

**SIVmac** infection was not restricted by any of our panel of rhesus TRIMs. None of the identified Mamu alleles were found to inhibit SIV infection (*Figs 5C and D*) and this finding is consistent with previous experiments (S. Wilson, unpublished results). Interestingly, cells expressing our TRIMs appear to be more permissive to SIVmac infection when compared with the untransduced cells, and those transduced with EXN (*Figs 5C and D*). This same trend was observed using either of the independently prepared viral stocks (*Table 4*). This suggests that expression of TRIM proteins might in fact increase cell susceptibility to this virus, perhaps due to dominant negative activity against undefined weak antivirals. It is also possible that TRIM5 $\alpha_{rh}$  expression in CRFK cells has deleterious effects that result in decreased cell proliferation. The reduced number of cells at the time of infection might increase the percentage infection resulting

in an apparent increase in susceptibility. This effect could be further examined using cell proliferation assays.

**MLV-B** infection was not restricted by any of the Mamu alleles in this study (*Fig 5E*).

This is consistent with published observations (16).

**MLV-N** infection was not inhibited by the Mamu alleles in this study (*Fig 5F*). This is inconsistent with previous findings reporting that MLV-N is partially blocked by TRIM5 $\alpha_{rh}$  (44). Additionally, our findings also contradict the observations by Newman *et al.* who reported that Mamu 1, 3, 4 and 5 efficiently restrict MLV-N (3). In this study none of the Mamu alleles exhibited strong restriction against this virus and this is also consistent with unpublished results from our lab (S. Wilson, personal communication). It is possible that the creation of our hybrid TRIM5 $\alpha$  molecules has resulted in the loss of restriction activity against this virus. However, in light of the fact that Mamu1, whose sequence is unaltered, does not restrict MLV-N infection in this assay, it is more likely that the expression levels of our TRIMs were too low to restrict MLV-N. The effects of reduced expression on MLV-N restriction were previously observed by Newman *et al.* (3)

**HIV-1** infection was restricted by Mamu 1, 3, 4, 5 and 8, by up to 10-fold. Additionally, FDFS showed a slight decrease in viral titres in comparison to the control cells (*Fig 5G*). Protection of cells from infection with this virus specifically by Mamu 1, 3, 4, and

5 is consistent with previous findings by Newman *et al.* (3) Mamu7 a truncated allele, did not inhibit HIV-1 (*Fig 5G*).

**HIV-2** infection was potently inhibited by Mamu1 and also inhibited by Mamu3 and 8 by up to 8-fold. A slight decrease in infection was also seen in cells transduced with FDFS (~ 3-fold). Mamu 4, 5 and 7 did not exhibit any antiviral activity against this virus (*Fig 5H*).

**EIAV** infection was restricted by all Mamu alleles tested in this study with the exception of Mamu7 and FDFS (*Fig 5I*).

In summary, infection with FIV, HIV-1, HIV-2 and EIAV could be restricted by some of the Mamu alleles tested while cells were not protected from SIV, MLV-B and MLV-N in this study. This illustrates differential restriction by particular alleles. Mamu7, a truncated allele with a 44 amino acid deletion did not restrict any of our panel of retroviruses. This suggests that the truncation is large enough to disrupt the internal structure of the B30.2 domain; possibly resulting in a molecule that does not fold into a functional B30.2 domain. Additionally, the loss of amino acids on the V3 region (for substrate binding) which are conserved in other alleles suggests a loss of retroviral capsid binding properties. In brief, this highlights that the truncation found in the B30.2 of this particular allele has possibly resulted in the loss of some essential residues that are necessary for viral recognition and binding. It is hard to imagine that this allele can



restrict any viruses however, its conservation within this species implies that it may have some protective properties against viruses that affect this species that have not yet been characterised. Interestingly, Mamu 4 and 5 are functional alleles, yet they do not restrict HIV-2. This suggests that the deletions and substitutions found in these alleles alter some determinants essential for HIV-2 restriction. Finally, these observations demonstrate that intra-species variation in the B30.2 domain results in different antiretroviral specificities. The maintenance of so many alleles within a population suggests balancing selection of the TRIM5 $\alpha$  locus. This in turn suggests repeated exposure to divergent pathogenic retroviruses throughout recent macaques evolution.

#### Dominant negative analysis

The simultaneous expression of TRIM5 $\gamma$  and TRIM5 $\delta$  with the wild type molecule illustrates that these two isoforms exert a dominant negative effect that represses restriction by TRIM5 $\alpha$ . Their expression increases permissivity of cells to viral infection and rescues restricted infectivity (1, 2, 11). TRIM5 $\alpha$  encoding a B-box 2 mutation has also been found to exert a dominant negative effect on the antiretroviral activity of the wildtype TRIM5 $\alpha$  against (5). Additionally, a functionally defective TRIM5 $\alpha$  mutant with the RING and B-box deleted can heterotrimerise with the wild type molecule and exert a dominant negative activity on retrovirus restriction (10). In this regard, we asked if the newly identified Mamu 7 with a truncated B30.2 also exhibits similar properties when co-expressed with an active allele and challenged with HIV-1 and HIV-2. In addition, we asked if Mamu 4 and 5, found to lack antiviral properties

against HIV-2 have dominant negative effects on the active TRIM5 $\alpha$ . We assessed dominant negative properties by co-expression of the wildtype TRIM5 $\alpha$  with TRIM5 $\alpha$  molecules encoding Mamu 1, 3, 8, 4, 5 and 7 and with TRIM34 as a positive control and an empty vector, EXN and untransduced cells as negative controls. TRIM34 contains a RING, B-box, coiled-coil and carboxyl-terminal B30.2 domain and it is 56.9% identical to TRIM5 $\alpha_{rh}$  yet it lacks antiretroviral activity and does not restrict HIV-1 (44, 45). Expression of this protein in cells results in increased susceptibility to HIV-1 infection when compared to cells transduced with an empty vector (44). This TRIM molecule was therefore used as a positive control in this experiment because it potently disrupts TRIM5 mediated restriction (44, 45). FRHK4 cells transduced with EXN and untransduced cells served as a negative control. The EXN control was important here because it shows that any apparent dominant negative effect is not caused by the Moloney MLV core used to deliver the EXN vector saturating the restriction factor.

Western blot results to assess the expression of the TRIM5 $\alpha$  molecules with various Mamu alleles and TRIM34 revealed faint bands at molecular mass marker around 55kDa were visualised on the X-ray film, (*results not shown*) this is consistent with the size of the wild type monomer TRIM5 $\alpha_{rh}$  which has a molecular mass of 54 to 56 kDa. Unfortunately, the bands were too faint to scan and this experiment will be repeated. FRHK4 cells (homozygous for Mamu 1 TRIM5 $\alpha$ ) were transduced with TRIM5 $\alpha$  molecules expressing various TRIM5 $\alpha$  alleles or TRIM34 or an empty vector, and incubated for 48 hours as previously described. The cells were then infected with

serially diluted doses of GFP encoding HIV-1 and HIV-2. The percentage infection for each dose of GFP encoding virus was determined using FACS, and bar chart plots to analyse the data were constructed as previously described (*Fig 6*).

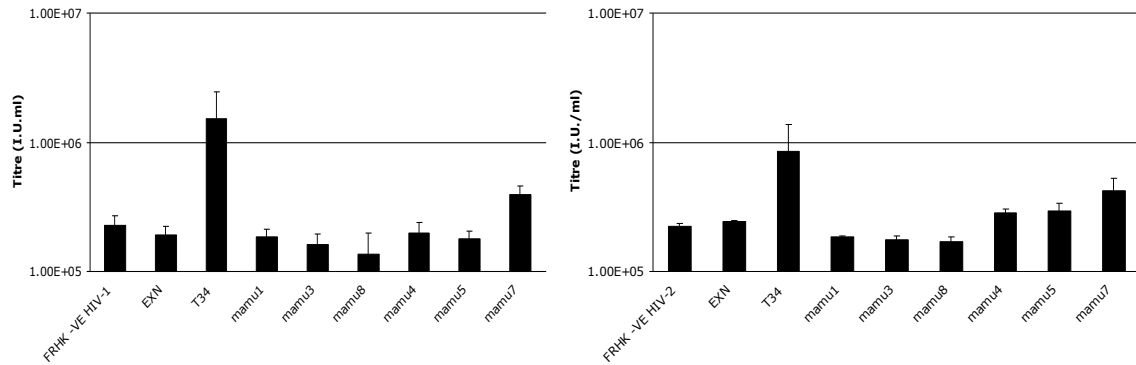

**Fig 6: Dominant negative properties of the identified Mamu alleles.** The dominant negative effects of Mamu alleles against the wildtype TRIM5 $\alpha$  was tested following co-expression of the wildtype TRIM5 $\alpha$  and various Mamu alleles and TRIM34 in FRHK4 cells and incubation with HIV-1 and HIV-2. EXN denotes co-expression of the wildtype with an untransduced empty vector.

As expected, both HIV-1 and HIV-2 were restricted by the unmodified FHRK4 cells and those transduced with an empty vector. Furthermore, both viruses were restricted by FRHK4 exogenously expressing Mamu 1, 3 and 8 illustrating that these alleles have no dominant negative activity towards Mamu 1. Co-expression of Mamu 1 and Mamu 8 showed additive restriction resulting in enhanced antiviral activity towards HIV-1 in comparison with unmodified FRHK cells. Conversely, the truncated Mamu7 was found to exert dominant negative activity against Mamu 1 weakly rescuing infectivity of both viruses particularly for HIV-1. This suggests that this allele can heterotrimerise with the Mamu 1 and interfere with its ability to restrict HIV-1 and HIV-2. Mamu 4 and 5 expression does not appear to rescue infectivity of either virus (infectivity is only

slightly attenuated in HIV-2) the FRHK4 cells expressing these proteins appear to restrict as well as unmodified cells. This is surprising in HIV-2 infection considering that neither allele restricts HIV-2 (*Fig 5H*).

## Discussion

Variations among primate TRIM5 $\alpha$  sequences are responsible for differences in restriction properties towards retroviruses (5). The B30.2 domain encodes the main antiviral restriction determinant for TRIM5 $\alpha$  (3). We analysed the restriction properties of TRIM5 $\alpha$  molecules from individuals from the same species. We have confirmed that intra-species polymorphism of this molecule exists and have shown that it has an impact on retroviral restriction specificity. The retroviral capsid encodes the determinant for restriction susceptibility by a particular TRIM5 $\alpha$  (10). This implies that the TRIM5 $\alpha$  recognition and binding sites on retroviral capsid proteins are not exclusively conserved and thus there may be slight differences in viral susceptibility to the antiviral activity of a particular TRIM. Therefore this is taken to explain lack of inhibition of SIVmac, MLV-B and MLV-N by all of the identified and tested Mamu alleles. Although highly unlikely, it is also possible that the creation of our hybrid TRIM5 $\alpha$  molecules has resulted in the loss of restriction properties against these viruses; alternatively, it is possible that the expression levels of our TRIMs were too low to restrict some of these viruses. Mamu7, the truncated allele moderately restricted HIV-2 although its restriction properties were less potent in comparison to the wildtype allele. Furthermore this allele did not inhibit the rest of the viruses in this study suggesting that the loss of 44 amino acids within the B30.2 of this allele has resulted in improper folding of the molecule and inability to confer viral recognition and binding properties. Interestingly, expression of Mamu7 together with the wildtype TRIM5 $\alpha$  allele was found to slightly attenuate restriction in a dominant negative manner following challenge with HIV-1 and HIV-2. This suggests that this allele can trimerise with the wildtype allele and has not lost this

ability. TRIM34 was found to exert strong dominant negative properties towards the wildtype TRIM5 $\alpha$  molecule following co-expression and challenge with HIV-1 and HIV-2.

Polymorphism of TRIM5 $\alpha$  is observed in this study and it is thought that the reason why these differences occur and are conserved in nature is because there are numerous retroviruses that have infected the rhesus macaques population and caused TRIM5 $\alpha$  selection. Mamu 3 is the most common allele in both Indian and Chinese macaques (*Table 2*) and it is the most functional, with an effect on a par with Mamu 1. The frequency of this allele in this population highlights that balancing selection may have favoured it above other alleles for this reason. The conservation of a non-functional Mamu7 allele at high frequencies within the Indian macaques might be driven by toxicity of active TRIM5 molecules. Alternatively this allele might also protect animals from viruses that remain to be defined and are not tested in this study.

In conclusion, we have shown that intra-species polymorphism within the TRIM5 $\alpha$  molecule has an effect on retroviral restriction. Apart from Mamu 7, the truncated allele, none of the tested alleles were shown to exert a dominant negative effect towards Mamu 1 following co-expression and retroviral challenge. These findings contribute to the understanding of cellular restriction factors which equally contribute to the improvement of animal model for AIDS as it will allow for the screening and selection of animals and also the exclusion of animals carrying alleles such as Mamu3 that might inhibit a virus of choice for an animal model.

## **Future work**

We have shown that intra-species polymorphism of the TRIM5 $\alpha$  molecule has an effect on retroviral restriction. The next possible study would be to investigate the specific mutation that results in differences in restriction properties by examining the contribution of each point mutation or deletion that differs within the Mamu alleles. For example there are only three differences between the sequences of Mamu 3 and Mamu 4 yet Mamu 4 does not restrict HIV-2 while Mamu 3 does. There is a need to elucidate if one of these differences is responsible for differential restriction properties against HIV-2. A generation of B30.2 domains containing each of these differences on their own might highlight the mutation that is responsible for loss of HIV-2 restriction. It will also be interesting to consider why an apparently inactive allele of TRIM5 (Mamu 7) is retained within the macaque population at such high frequency.

## References

1. Song, B., Gold, B., O'Huigin, C., Javanbakht, H., Li, X., Stremlau, M., Winkler, C., Dean, M. and Sodroski, J. (2005b). The B30.2(SPRY) domain of the retroviral restriction factor TRIM5 $\alpha$  exhibits lineage-specific length and sequence variation in primates. *J. Virol.* *79(10)*, 6111-6121.
2. Towers, G.J. (2007). The control of viral infection by tripartite motif proteins and cyclophilin A. *Retrovirology.* *4(40)*.
3. Newman, R.M., Hall, L., Connole, M., Chen, G.L., Sato, S., Yuste, E., Diehl, W., Hunter, E., Kaur, A., Miller, G.M., Johnson, W.E. (2006). Balancing selection and the evolution of functional polymorphism in Old World monkey TRIM5 $\alpha$ . *Proc. Natl. Acad. Sci. USA* *103(50)*, 19134-19139.
4. Song, B., Javanbakht, H., Perron, M., Park, D.H., Stremlau, M. and Sodroski, J. (2005). Retrovirus restriction by TRIM5 $\alpha$  variants from old world and new world primates. *J. Virol.* *79(7)*, 3930-3937.
5. Javanbakht, H., Diaz-Griffero, F., Stremlau, M. and Sodroski, J. (2005) The contribution of RING and B-box domains to retroviral restriction by monkey TRIM5 $\alpha$ . *The J. Biol Chem.* *280(29)*, 26933-26940.
6. Doyle, S., Vaidya, S., O'Connell, R., Dadgostar, H., Dempsey, P., Wu, T., Rao, G., Sun, R., Haberland, M. and Cheng, G. (2002). IRF3 mediates a TLR3/TLR4-specific antiviral gene program. *Immunity.* *17(3)*, 251-263
7. Luban, J. (2007). Cyclophilin A, TRIM5, and Resistance to HIV-1 Infection. *J. Virol.* *81(3)*, 1054-1061.
8. Rhodes, D.A., de Bono, B., Trowsdale, J. (2005). Relationship between SPRY and B30.2 protein domains. Evolution of a component of immune defence? *Immunology.* *116(4)*, 411-417.
9. Stremlau, M., Perron, M., Lee, M., Li, Y., Song, B., Javanbakht, H., Diaz-Griffero, F., Anderson, D.A., Sundquist, W.I. and Sodroski, J. (2006). Specific recognition and accelerated uncoating of retroviral capsids by the TRIM5 $\alpha$  restriction factor. *PNAS.* *103(14)*, 5514-5519.
10. Mische, C.C., Javanbakht, H., Song, B., Diaz-Griffero, F., Stremlau, M., Strack, B., Si, Z. and Sodroski, J. (2005). Retroviral restriction factor TRIM5 $\alpha$  is a trimer. *J. Virol.* *79(22)*, 14446-14450.
11. Passerini, L.D., Keckesova, Z. and Towers, G.J. (2005). Retroviral restriction factors Fv1 and TRIM5 $\alpha$  act independently and can compete for incoming virus before reverse transcription. *J. Virol.* *80(5)*, 2100-2105.
12. Sebastian, S., Luban, J. (2005). TRIM5 $\alpha$  selectively binds a restriction-sensitive retroviral capsid. *Retrovirology* *2(40)*.
13. Ohkura, S., Yap, M.W., Sheldon, T., Stoye, J.P. (2006). All three variable regions of the TRIM5 $\alpha$  B30.2 domain can contribute to the specificity of retrovirus restriction. *J. Virol.* *80(17)*, 8554-8565.
14. Nisole, S., Stoye, J.P., Saib, A. (2005). TRIM family proteins: retroviral restriction and antiviral defence. *Nat. Rev. Microbiol.* *3(10)*, 799-808.
15. Wu, Xiaolu., Anderson, J.L., Campbell, E.M., Joseph, A.M. and Hope, T.J. (2006). Proteasome inhibitors uncouple rhesus TRIM5 $\alpha$  restriction of HIV-1 reverse transcription and infection. *PNAS.* *103(19)*, 7465-7470.



16. Towers, G.J. (2005). Control of viral infectivity by tripartite motif proteins. *Hum. Gene Ther.* *16(10)*, 1125-1132.
17. Towers, G.J. (2006). Restriction of retroviruses by. *Future Virology*, *1 (1)*, 71-78.
18. Meroni, G., Diez-Roux, G. (2005). TRIM/RBCC, a novel class of 'single protein RING finger' E3 ubiquitin ligases. *Bioessays* *27(11)*, 1147-1157.
19. Javanbakht, H., An, P., Gold, B., Petersen, D.C., O'Huigin, C., Nelson, G.W., O'Brien, S.J., Kirk, G.D., Detels, R., Buchbinder, S., Donfield, S., Shulenin, S., Song, B., Perron, M.J., Stremlau, M., Sodroski, J., Dean, M., Winkler, C. (2006a). Effects of human TRIM5 $\alpha$  polymorphisms on antiretroviral function and susceptibility to human immunodeficiency virus infection. *Virology* *354(1)*, 15-27.
20. Freed, E.O., Ross, S.R. (2004). Retroviruses, Review of the 2004 Cold Spring Harbor Retroviruses conference. *Retrovirology*. *1(25)*.
21. Stremlau, M., Owens, C.M., Perron, M.J., Kiessling, M., Autissier, P. and Sodroski, J. (2004). The cytoplasmic body component TRIM5 $\alpha$  restricts HIV-1 infection in Old World monkeys. *Nature* *427(6977)*, 848-853.
22. Campbell, E. M., Dodding, M. P., Yap, M. W., Wu, X., Gallois-Montbrun, S., Malim, M. H., Stoye, J. P., Hope, T. J. (2007) TRIM5 $\alpha$  cytoplasmic bodies are highly dynamic structures. *Molecular biology of the Cell*, MBC Online. 10.1091/mbc.E06-12-1075
23. Cohen et al. 2005 Research at the extremes: Presentations at Keystone 2005 focused on both very early and prolonged infection to try to discern what an effective vaccine might need to do. *International AIDS Vaccine Initiative (IAVI) REPORT* *9(2)*.
24. Forshey, B.M., von Schwedler, U., Sundquist, W. I. and Aiken, C. (2002). Formation of a human immunodeficiency virus type 1 core of optimal stability is crucial for viral replication. *J. Virol.* *76(11)*, 5667-5677.
25. Chatterji, U., Bobardt, M.D., Gaskill, P., Sheeter, D., Fox, H. and Gallyard, P.A. (2006). TRIM5 $\alpha$  accelerates degradation of cytosolic capsid associated with productive HIV-1 entry. *J. Biol Chem.* *281(48)*, 37025-37033.
26. Anderson, J.L., Campbell, E.M., Wu, X., Vandegraaff, N., Engelman, A. and Hope, T.J. (2006). Proteasome inhibition reveals that functional preintegration complex intermediate can be generated during restriction by diverse TRIM5 proteins. *J. Virol.* *80(19)*, 9754-9760.
27. James, L. C., Keeble, A. H., Khan, Z., Rhodes, D. A., Trowsdale, J. (2007). Structural basis for PRYSPRY-mediated tripartite motif (TRIM) protein function. *PNAS*, *104(15)*, 6200-6205
28. Ylinen, L.M., Keckesova, Z., Webb, B.L., Gifford, R.J., Smith, T.P., Towers, G.J. (2006). Isolation of an active Lv1 gene from cattle indicates that tripartite motif protein-mediated innate immunity to retroviral infection is widespread among mammals. *J. Virol.* *80(15)*, 7332-7338.
29. Sakuma, R., Noser, J. A., Ohmine, S., Ikeda, Y. (2007). Rhesus monkey TRIM5 $\alpha$  restricts HIV-1 production through rapid degradation of viral Gag polyproteins. *Nature medicine.* *13(5)*, 631-5.

30. Ylinen, L.M., Keckesova, Z., Wilson, S.J., Ranasinghe, S., Towers, G.J. (2005). Differential restriction of human immunodeficiency virus type 2 and simian immunodeficiency virus SIVmac by TRIM5alpha alleles. *J. Virol.* *79(18)*, 11580-11587.
31. <http://www.madsci.org/posts/archives/aug97/866644181.Cb.r.html> [MadSci Network](#): Cell Biology
32. Sawyer, S.L., Wu, L.I., Akey, J.M., Emerman, M., Malik, H.S. (2006). High-frequency persistence of an impaired allele of the retroviral defense gene TRIM5alpha in humans. *Curr. Biol.* *16(1)*, 95-100.
33. Stremlau, M., Perron, M., Welikala, S., Sodroski, J. (2005). Species-specific variation in the B30.2(SPRY) domain of TRIM5alpha determines the potency of human immunodeficiency virus restriction. *J. Virol.* *79(5)*, 3139-3145.
34. Woo, J-S., Imm, J-H., Min, C-K., Kim, K-J., Cha, S-S., Oh, B-H. (2006). Structural and functional insights into the B30.2/SPRY domain. *The EMBO Journal.* *25(6)*, 1353-1363.
35. Owens, C.M., Yang, P.C., Gottlinger, H. and Sodroski, J. (2003). Human and simian immunodeficiency virus capsid proteins are major viral determinants of early, post entry replication blocks in simian cells. *J. Virol.* *77(1)*, 726-731.
36. Griffin, S.D., Allen, J.F. and Lever, A.M. (2001) The major human immunodeficiency virus type 2 (HIV-2) packaging signal is present on all HIV-2 RNA species: cotranslational RNA encapsidation and limitation of Gag protein confer specificity. *J. Virol.* *75(24)*, 12058-12069
37. Besnier, C., Takeuchi, Y. and Towers, G. (2002). Restriction of lentivirus in monkeys. *PNAS.* *99()*, 11920-11925.
38. Zufferey, R., Nagy, D., Mandel, R.J., Naldini, L. and Trono, D. (1997). Multiply attenuated lentiviral vector achieves efficient gene delivery in vivo. *Nat. Biotechnol.* *15(9)*, 871-875
39. Ikeda, Y., Ylinen, L., Kahar-Bador, M. and Towers, G.J. (2004). The influence of gag on HIV-1 species specific tropism. *J. Virol.* *78(21)*, 11816-11822.
40. Towers, G., Bock, M., Martin, S., Takeuchi, Y., Stoye, J.P. and Danos, O. (2000). A conserved mechanism of retrovirus restriction in mammals. *PNAS.* *97(22)*, 12295-12299.
41. Mitrophanous, K., Yoon, S., Rohll, J., Patil, D., Wilkes, F., Kim, V., Kingsman, S., Kingsman, A. and Mazarakis, N. (1999) Stable gene transfer to the nervous system using a non-primate lentiviral vector. *Gene Ther.* *6(11)*, 1808-18.
42. Bock, M., Bishop, K.N., Towers, G. and Stoye, J.P. (2000) Use of a transient assay for studying the genetic determinants of Fv1 restriction. *74(16)*, 7422-7430
43. Negre D, Mangeot P E, Duisit G, Blanchard S, Vidalain P O, Leissner P, Winter A J, Rabourdin-Combe C, Mehtali M, Moullier P, Darlix JL, Cosset FL. (2000) Characterization of novel safe lentiviral vectors derived from simian immunodeficiency virus (SIVmac251) that efficiently transduce mature human dendritic cells. *Gene Ther.* *7(19)*, 1613-23.
44. Li, X., Li, Y., Stremlau, M., Yuan, W., Song, B., Perron, M. and Sodroski, J. (2006) Functional replacement of the RING, B-box 2 and coiled coil domains of

- tripartite motif 5 $\alpha$  (TRIM5 $\alpha$ ) by heterologous TRIM domains. *J. Virol.* 80(13), 6198-6206
45. Zhihai, S., Vandegraaf, N., O'hUigin, C., Song, B., Yuan, W., Xu, C., Perron, M., Li, X., Marasco, W.A., Engelman, A., Dean, M. and Sodroski, J. (2006). Evolution of cytoplasmic tripartite motif (TRIM) protein in cows that restricts retroviral infection. *PNAS* 103(19), 7454-7459.

### Background reading

- Keckesova, Z., Ylinen, L.M. and Towers, G.J. (2004). The human and African green monkey TRIM5 $\alpha$  genes encode Ref1 and Lv1 retroviral restriction factor activities. *PNAS* 101(29), 10780–10785.
- Towers, G.J., Goff, S.P., (2003). Post-entry restriction of retroviral infections. *AIDS Reviews.* 5, 163-171
- Keckesova, Z., Ylinen, L.M. and Towers, G.J. (2006). Cyclophilin A renders human immunodeficiency virus type 1 sensitive to old world monkey but not human TRIM5 $\alpha$  antiviral activity. *J. Virol.* 80(10), 4683-4690.

## **Appendix**

### Western Blot

#### SDS-PAGE (12.5% Running Gel made to a total volume 30mls)

30% acrylamide  
2% isoacrylamide  
20% SDS  
1M Tris-HCL (pH 8.8)  
1M Tris-HCL (pH 6.8)  
20% APS (ammonium persulfate)  
TEMED  
Deionised water

#### Loading Buffer

20% glycerol  
5.2% SDS  
200mM (pH 6.8) Tris-HCL  
Bromophenol Blue (BPB)  
Water  
300mM SDS (add on day of use)