

Systematic review of isolation policies in the hospital management of methicillin-resistant *Staphylococcus aureus*: a review of the literature with epidemiological and economic modelling

BS Cooper

SP Stone

CC Kibbler

BD Cookson

JA Roberts

GF Medley

GJ Duckworth

R Lai

S Ebrahim



Health Technology Assessment
NHS R&D HTA Programme

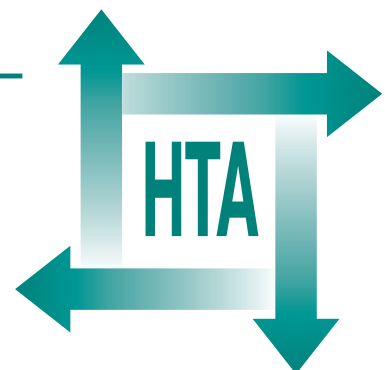



INAHTA

How to obtain copies of this and other HTA Programme reports.

An electronic version of this publication, in Adobe Acrobat format, is available for downloading free of charge for personal use from the HTA website (<http://www.hta.ac.uk>). A fully searchable CD-ROM is also available (see below).

Printed copies of HTA monographs cost £20 each (post and packing free in the UK) to both public **and** private sector purchasers from our Despatch Agents.

Non-UK purchasers will have to pay a small fee for post and packing. For European countries the cost is £2 per monograph and for the rest of the world £3 per monograph.

You can order HTA monographs from our Despatch Agents:

- fax (with **credit card** or **official purchase order**)
- post (with **credit card** or **official purchase order** or **cheque**)
- phone during office hours (**credit card** only).

Additionally the HTA website allows you **either** to pay securely by credit card **or** to print out your order and then post or fax it.

Contact details are as follows:

HTA Despatch
c/o Direct Mail Works Ltd
4 Oakwood Business Centre
Downley, HAVANT PO9 2NP, UK

Email: orders@hta.ac.uk
Tel: 02392 492 000
Fax: 02392 478 555
Fax from outside the UK: +44 2392 478 555

NHS libraries can subscribe free of charge. Public libraries can subscribe at a very reduced cost of £100 for each volume (normally comprising 30–40 titles). The commercial subscription rate is £300 per volume. Please see our website for details. Subscriptions can only be purchased for the current or forthcoming volume.

Payment methods

Paying by cheque

If you pay by cheque, the cheque must be in **pounds sterling**, made payable to *Direct Mail Works Ltd* and drawn on a bank with a UK address.

Paying by credit card

The following cards are accepted by phone, fax, post or via the website ordering pages: Delta, Eurocard, Mastercard, Solo, Switch and Visa. We advise against sending credit card details in a plain email.

Paying by official purchase order

You can post or fax these, but they must be from public bodies (i.e. NHS or universities) within the UK. We cannot at present accept purchase orders from commercial companies or from outside the UK.

How do I get a copy of HTA on CD?

Please use the form on the HTA website (www.hta.ac.uk/htacd.htm). Or contact Direct Mail Works (see contact details above) by email, post, fax or phone. *HTA on CD* is currently free of charge worldwide.

The website also provides information about the HTA Programme and lists the membership of the various committees.

Systematic review of isolation policies in the hospital management of methicillin-resistant *Staphylococcus aureus*: a review of the literature with epidemiological and economic modelling

BS Cooper¹

SP Stone^{1*}

CC Kibbler²

BD Cookson^{3,4}

JA Roberts⁴

GF Medley⁵

GJ Duckworth⁶

R Lai⁷

S Ebrahim⁸

¹ Academic Department of Geriatric Medicine, Royal Free Campus, Royal Free and University College Medical School, University of London, UK

² University Department of Medical Microbiology, Royal Free Campus, Royal Free and University College Medical School, University of London, UK

³ Laboratory of HealthCare Associated Infection, Health Protection Agency, London, UK

⁴ Health Services Research Unit, Department Public Health and Policy, London School of Hygiene Tropical Medicine, University of London, UK

⁵ Ecology and Epidemiology, Department of Biological Sciences, University of Warwick, Coventry, UK

⁶ Division of Healthcare-Associated Infection and Antimicrobial Resistance, Health Protection Agency, Communicable Disease Surveillance Centre, London, UK

⁷ University Library, Royal Free Campus, Royal Free and University College Medical School, University of London, UK

⁸ Department of Social Medicine, Bristol University Medical School, University of Bristol, UK

* Corresponding author

Declared competing interests of authors: none

Published December 2003

This report should be referenced as follows:

Cooper BS, Stone SP, Kibbler CC, Cookson BD, Roberts JA, Medley GF, *et al.* Systematic review of isolation policies in the hospital management of methicillin-resistant *Staphylococcus aureus*: a review of the literature with epidemiological and economic modelling. *Health Technol Assess* 2003;7(39).

Health Technology Assessment is indexed in *Index Medicus/MEDLINE* and *Excerpta Medica/EMBASE*.

NHS R&D HTA Programme

The NHS R&D Health Technology Assessment (HTA) Programme was set up in 1993 to ensure that high-quality research information on the costs, effectiveness and broader impact of health technologies is produced in the most efficient way for those who use, manage and provide care in the NHS.

Initially, six HTA panels (pharmaceuticals, acute sector, primary and community care, diagnostics and imaging, population screening, methodology) helped to set the research priorities for the HTA Programme. However, during the past few years there have been a number of changes in and around NHS R&D, such as the establishment of the National Institute for Clinical Excellence (NICE) and the creation of three new research programmes: Service Delivery and Organisation (SDO); New and Emerging Applications of Technology (NEAT); and the Methodology Programme.

This has meant that the HTA panels can now focus more explicitly on health technologies ('health technologies' are broadly defined to include all interventions used to promote health, prevent and treat disease, and improve rehabilitation and long-term care) rather than settings of care. Therefore the panel structure was replaced in 2000 by three new panels: Pharmaceuticals; Therapeutic Procedures (including devices and operations); and Diagnostic Technologies and Screening.

The HTA Programme will continue to commission both primary and secondary research. The HTA Commissioning Board, supported by the National Coordinating Centre for Health Technology Assessment (NCCHTA), will consider and advise the Programme Director on the best research projects to pursue in order to address the research priorities identified by the three HTA panels.

The research reported in this monograph was funded as project number 97/07/01.

The views expressed in this publication are those of the authors and not necessarily those of the HTA Programme or the Department of Health. The editors wish to emphasise that funding and publication of this research by the NHS should not be taken as implicit support for any recommendations made by the authors.

Criteria for inclusion in the HTA monograph series

Reports are published in the HTA monograph series if (1) they have resulted from work commissioned for the HTA Programme, and (2) they are of a sufficiently high scientific quality as assessed by the referees and editors.

Reviews in *Health Technology Assessment* are termed 'systematic' when the account of the search, appraisal and synthesis methods (to minimise biases and random errors) would, in theory, permit the replication of the review by others.

HTA Programme Director: Professor Kent Woods
Series Editors: Professor Andrew Stevens, Dr Ken Stein, Professor John Gabbay,
Dr Ruairidh Milne, Dr Chris Hyde and Dr Rob Riemsma
Managing Editors: Sally Bailey and Sarah Llewellyn Lloyd

The editors and publisher have tried to ensure the accuracy of this report but do not accept liability for damages or losses arising from material published in this report. They would like to thank the referees for their constructive comments on the draft document.

ISSN 1366-5278

© Queen's Printer and Controller of HMSO 2003

This monograph may be freely reproduced for the purposes of private research and study and may be included in professional journals provided that suitable acknowledgement is made and the reproduction is not associated with any form of advertising.

Applications for commercial reproduction should be addressed to HMSO, The Copyright Unit, St Clements House, 2-16 Colegate, Norwich, NR3 1BQ.

Published by Gray Publishing, Tunbridge Wells, Kent, on behalf of NCCHTA.
Printed on acid-free paper in the UK by St Edmundsbury Press Ltd, Bury St Edmunds, Suffolk.



Abstract

Systematic review of isolation policies in the hospital management of methicillin-resistant *Staphylococcus aureus*: a review of the literature with epidemiological and economic modelling

BS Cooper,¹ SP Stone,^{1*} CC Kibbler,² BD Cookson,^{3,4} JA Roberts,⁴ GF Medley,⁵ GJ Duckworth,⁶ R Lai⁷ and S Ebrahim⁸

¹ Academic Department of Geriatric Medicine, Royal Free Campus, Royal Free and University College Medical School, University of London, UK

² University Department of Medical Microbiology, Royal Free Campus, Royal Free and University College Medical School, University of London, UK

³ Laboratory of HealthCare Associated Infection, Health Protection Agency, London, UK

⁴ Health Services Research Unit, Department Public Health and Policy, London School of Hygiene Tropical Medicine, University of London, UK

⁵ Ecology and Epidemiology, Department of Biological Sciences, University of Warwick, Coventry, UK

⁶ Division of Healthcare-Associated Infection and Antimicrobial Resistance, Health Protection Agency, Communicable Disease Surveillance Centre, London, UK

⁷ University Library, Royal Free Campus, Royal Free and University College Medical School, University of London, UK

⁸ Department of Social Medicine, Bristol University Medical School, University of Bristol, UK

* Corresponding author

Objective: To review the evidence for the effectiveness of different isolation policies and screening practices in reducing the incidence of methicillin-resistant *Staphylococcus aureus* (MRSA) colonisation and infection in hospital in-patients. To develop transmission models to study the effectiveness and cost-effectiveness of isolation policies in controlling MRSA.

Data sources: MEDLINE, EMBASE, CINAHL, The Cochrane Library and SIGLE (1966–2000). Hand-searching key journals. No language restrictions.

Review methods: Key data were extracted from articles reporting MRSA-related outcomes and describing an isolation policy in a hospital with epidemic or endemic MRSA. No quality restrictions were imposed on studies using isolation wards (IW) or nurse cohorting (NC). Other studies were included if they were prospective or employed planned comparisons of retrospective data. Stochastic and deterministic models investigated long-term transmission dynamics, studying the effect of a fixed capacity IW, producing economic evaluations using local cost data.

Results: A total of 46 studies were accepted: 18 IWs, 9 NC, 19 other isolation policies. Most were

interrupted time series, with few planned formal prospective studies. All but one reported multiple interventions. Consideration of potential confounders, measures to prevent bias, and appropriate statistical analysis were mostly lacking. No conclusions could be drawn in a third of studies. Most others provided evidence consistent with reduction of MRSA acquisition. Six long interrupted time series provided the strongest evidence. Four of these provided evidence that intensive control measures which included patient isolation were effective in controlling MRSA. In two others IW use failed to prevent endemic MRSA. There was no robust economic evaluation. Models showed that improving the detection rate or ensuring adequate isolation capacity reduced endemic levels, with substantial savings achievable.

Conclusions: Major methodological weaknesses and inadequate reporting in published research mean that many plausible alternative explanations for reductions in MRSA acquisition associated with interventions cannot be excluded. No well-designed studies allow the role of isolation measures alone to be assessed.

Nonetheless, there is evidence that concerted efforts that include isolation can reduce MRSA even when endemic. Little evidence was found to suggest that current isolation measures recommended in the UK are ineffective, and these should continue to be applied

until further research establishes otherwise. The studies with the strongest evidence, together with the results of the modelling, provide testable hypotheses for future research. Guidelines to facilitate design of future research are produced.



Contents

Glossary and list of abbreviations	vii	5 Modelling of transmission dynamics and economics of control of MRSA by patient isolation	53
Executive summary	xi	Rationale	53
I Introduction	1	Background	53
<i>Staphylococcus aureus</i> and MRSA	1	Model without patient isolation	54
Increasing antimicrobial resistance	2	Model with patient isolation	58
Control of MRSA	2	Isolation model with economics	63
Outcome of control measures	3	Discussion	70
Aims of the systematic review	4	6 Discussion	75
2 Threats to valid inference	5	Methodological aspects of the review	75
Introduction	5	Quality of included studies	76
Terminology	5	Assessment of control measures	77
Internal validity	5	Mathematical modelling and economic evaluation	78
Assessing reporting bias and regression to the mean.....	8	Conclusions and implications for healthcare and research	78
Construct validity	12	Recommendations for future research	79
Statistical conclusion validity	12	Acknowledgements	83
External validity	14	References	85
Conclusions	15	Appendix 1 Search strategy	99
3 Systematic review methods	17	Appendix 2 Table of excluded studies	103
Search strategy	17	Appendix 3 Full summary tables of data extraction for accepted studies	111
Abstract appraisal	18	Appendix 4 Modelling and economic equations	173
Initial article appraisal	19	Appendix 5 Recommendations for publication of MRSA outbreak reports and intervention studies	177
Full article appraisal	19	Health Technology Assessment reports published to date	183
Data extraction	19	Health Technology Assessment Programme	191
Author correspondence	20		
Final inclusion/exclusion decisions	21		
4 Results of systematic literature review	23		
Search results	23		
Data extracted from accepted studies	23		
General characteristics of accepted studies	24		
Threats to internal validity	25		
Threats to construct validity	27		
Threats to statistical conclusion validity	27		
Assessment of evidence for control of MRSA by interventions in accepted studies	28		
Isolation ward studies	28		
Designated nursing staff (NC) studies	35		
Other isolation policies reports	39		
Economic evaluation	49		
Overall conclusions of literature review	49		



Glossary and list of abbreviations

Technical terms and abbreviations are used throughout this report. The meaning is usually clear from the context, but a glossary is provided for the non-specialist reader. In some cases, usage differs in the literature, but the terms have a constant meaning throughout this review.

Glossary

Antibiotic policy The provision of guidelines for use of antimicrobials.

Barrier nursing See Isolation.

Basic reproduction number (R_0) A measure of the transmissibility of infection, due to characteristics of both the infectious agent and the environment, e.g. increased hand-hygiene decreases R_0 . More formally defined for our purposes as the number of secondary cases of MRSA arising from one case in a hospital completely free of MRSA.

Bias Any process associated with data collection, analysis or reporting resulting in systematic deviation of results or inferences from the truth.

Carriage The harbouring of MRSA at recognised carriage sites (e.g. nose, throat, perineum) with no overt expression of clinical disease. See also Colonisation.

Clearance The successful eradication of MRSA from previously colonised (and infected) sites.

Closed bay A room capable of accommodating more than one patient and separated from the rest of the ward by full-length walls and a door.

Cohorting Physical segregation of a group of patients with MRSA from patients not known to harbour MRSA in a geographically distinct area of the same ward, but nursed by the same group of staff. There may or may not be physical separation, such as use of a closed bay (see above). Sometimes referred to as patient cohorting (see also Nurse cohorting).

Colonisation The presence of MRSA at a body site without clinical or subclinical disease. See also Carriage, Infection.

Confounders Factors distorting the ability to attribute the cause of something to the intervention because another factor could be influencing the result. This other confounding factor is associated with the intervention, but is not on the causal pathway between intervention and outcome. For example, if the intervention is the opening of an isolation ward, but this happens to occur at the same time as an increase in staff handwashing unrelated to the intervention, then staff handwashing would be a confounding factor.

Endemic MRSA The continuous presence of MRSA over a prolonged period of time in a ward or hospital (i.e. not necessarily the same individual patients), whether or not transmission is shown to have occurred. For individual studies, we also considered MRSA to be endemic if the authors stated this. See also Outbreak.

Eradication The use of topical or systemic antibiotics to clear colonised sites of MRSA. Agents used for topical eradication include mupirocin, triclosan, chlorhexidine, naseptin (chlorhexidine and neomycin) and bacitracin. Agents used for systemic eradication include rifampicin, fusidic acid, trimethoprim and sulphamethoxazole.

External validity The extent to which findings from studies can be validly generalised to other settings.

Fadeout The termination of a chain of MRSA transmission with removal of the last colonised or infected individual in the specified population. Usually used in the context of a chance elimination of MRSA, rather than intentional following interventions.

continued

Glossary continued

Feedback The reporting back to healthcare workers of outcomes relevant to MRSA control. This may include primary outcomes (MRSA infection or colonisation rates) or secondary outcomes (hand-hygiene compliance or antibiotic policy compliance).

Handwashing education Any explicit measure intended to increase staff handwashing compliance or technique through raising staff awareness.

Incidence Any measure of the number of events (infections, colonisations, bacteraemias, etc.) occurring *per unit time*. If expressed per patient, then denominators may include number of exposed patients, number of exposed patient-days, etc. Often it is not possible to distinguish new cases of colonisation/carriage from new detections of existing cases; we allow incidence to refer to both.

Infection The presence or replication of microorganisms in the tissues of a host. When discussing results in individual papers we followed the infection definitions used by authors. An exception to this rule was made for papers that described all patients harbouring MRSA as infected. In such cases we considered individuals described as infected to be either infected or colonised.

Internal validity The extent to which inferences made about causal relationships between interventions and outcomes are true.

Interrupted time series Outcome data in the form of multiple outcome measures before and after one or more interventions.

Isolation The physical segregation of an MRSA patient (or of patients awaiting screening results) from others for the express purpose of limiting direct or indirect transmission of MRSA. For the purpose of this review isolation was categorised in descending order of intensity:

1. isolation unit or ward
2. cohorting with designated nursing staff (nurse cohorting)
3. single-room isolation
4. cohorting (without designated staff)

5. use of aprons or gowns, gloves and, in some cases masks, by healthcare workers as the only physical barrier to transmission (barrier nursing)
6. none.

Isolation unit/isolation ward Either a purpose-built or improvised ward used for the isolation of MRSA patients. In some cases also used for isolating patients suspected to carry MRSA, or having other infectious diseases. Isolation rooms that were part of other wards were not considered to be isolation units, even if they had controlled ventilation and their own nursing staff. Isolation in such rooms was classified as cohorting in closed bays (see above).

Length of stay The time spent by a patient in a ward or hospital. Usually used in terms of an average (mean) length of stay.

MRSA Any strains of *Staphylococcus aureus* described by the authors as being homogeneously or heterogeneously resistant to methicillin, oxacillin or other isoxazolyl penicillins. We did not require specific minimum inhibitory concentrations to be quoted or reference to agreed breakpoints.

MRSA case/MRSA patient Any patient who has been culture positive for MRSA during their current hospital stay or who has been identified as carrying MRSA from preadmission screening or by the institution they were transferred from (other hospital, nursing home, etc.).

MSSA Methicillin-sensitive *Staphylococcus aureus*. Any strain of *Staphylococcus aureus* that is not MRSA.

Nurse cohorting Physical segregation of a group of patients with MRSA from patients not known to harbour MRSA in a geographically distinct area of the same ward, and nursed by designated staff who do not nurse non-MRSA patients during the same shifts. There may or may not be physical separation, such as the use of closed bays (see above). Sometimes referred to as staff cohorting, although other members of staff (e.g. doctors, physiotherapists) rarely participate.

continued

Glossary continued

Open bay An area capable of accommodating more than one patient and in direct communication with the rest of the ward, without barriers to air flow.

Opportunity costs The benefits forgone by using resources in one way rather than in the next best alternative use. They represent the lost opportunities to use resources elsewhere. If there is a competitive market for the resource, price provides a good estimate of the opportunity costs; if the market is not functioning well, some way of estimating the value of the use of resources has to be adopted.

Outbreak Any episode of transmission of MRSA between patients was considered to constitute an outbreak regardless of the number of patients affected. In contrast to the endemic state, an outbreak was considered to be temporally limited. There is no clear division between an outbreak and endemicity: an outbreak may lead to endemicity, and endemic MRSA may be reduced to discrete outbreaks.

Overflow isolation policy The method of isolation used for MRSA patients who cannot be accommodated by the main isolation policy. For example, where the main policy is an isolation ward, the overflow policy when the ward is full might be single-room isolation. Where the main policy is single-room isolation, the overflow policy when single rooms are full might be cohorting, etc.

Phage type Designated strain type defined by its susceptibility to specific viruses or 'phages' in the laboratory.

Point prevalence The number of cases present in a specified population at one point in time. If expressed as a proportion or percentage, then the denominator must be stated.

Prevalence The number or proportion of cases in a specified population. The population may be defined in a number of ways, for example patients currently in a hospital or ward, or all patients having passed through a hospital in 1 year. A denominator is required.

Prospective study A study where data are systematically collected for the purpose of the study during the period being studied.

Regression to the mean A statistical phenomenon distorting results in comparative studies due to the non-random selection of initial observations. Such effects occur when chance factors have an important impact on the observations. The distortion occurs since, on average, an extreme observation of an event will be followed by a less extreme observation.

Reporting bias Bias resulting from selective reporting or publication of experimental or quasi-experimental results. Usually reporting bias can be expected to result in the over-representation of positive results (successful interventions) in the literature.

Retrospective study A study using historical data recorded for purposes other than for use in the current study.

Screening The sampling and culture of sites, such as skin lesions, nose, perineum and throat, that are associated with the carriage of MRSA.

Screening policy The policy adopted by a hospital to screen targeted individuals thought to be at risk of MRSA carriage, so that measures can be taken to prevent its further spread.

Seasonality A component of the variation in time series data that is dependent on the time of year.

Single-room isolation Isolation of patients in a single-bedded room. This definition includes the use of two or more bedded rooms for the isolation of one patient at a time.

Stochastic effects Chance effects. In the present context, stochastic effects result from the probabilistic nature of the underlying epidemic process.

Trend A long-term tendency (increasing or decreasing) in time series data.

Typing Characterisation of the MRSA strain type by phenotypic (e.g. antibiogram – the pattern of susceptibility to antibiotics), phage typing or genotypic methods (e.g. pulsed field gel electrophoresis, plasmid analysis).

List of abbreviations

ARIMA	autoregressive integrated moving average	IW	isolation ward or unit
CDC	Center for Disease Control and Prevention	LOS	length of stay
CDR	Communicable Disease Report	LRT	lower respiratory tract
CI	confidence interval	MeSH headings	Medical Subject Headings
CSU	catheter specimen of urine	MRSA	methicillin-resistant <i>Staphylococcus aureus</i>
CVC	central venous catheter	MSSA	methicillin-sensitive <i>Staphylococcus aureus</i>
DNA	deoxyribonucleic acid	NC	nurse cohorting
EMRSA	epidemic methicillin-resistant <i>Staphylococcus aureus</i>	NH	nursing home
EPOC	Effective Practice and Organisation of Care (Cochrane group)	NICU	neonatal intensive care unit
GISA	glycopeptide intermediate-resistant <i>Staphylococcus aureus</i>	PFGE	pulsed field gel electrophoresis
GRE	glycopeptide-resistant enterococci	PICU	paediatric intensive care unit
HAI	hospital-acquired infection	RCT	randomised controlled trial
HCW	healthcare worker	REAP	restriction endonuclease analysis of plasmid DNA
IC	infection control	RFLP	restriction fragment length polymorphism
ICN	infection control nurse	SCBU	special care baby unit
ICT	infection control team	SICU	surgical intensive care unit
ICU	intensive care unit	SIMU	surgical intermediate care unit
IMS	intensive microbiological surveillance	SD	standard deviation
ITS	interrupted time series	TMP/SMX	trimethoprim/sulphamethoxazole
ITU	intensive therapy unit	WIP	Werkgroep Infectiepreventie

All abbreviations that have been used in this report are listed here unless the abbreviation is well known (e.g. NHS), or it has been used only once, or it is a non-standard abbreviation used only in figures/tables/appendices in which case the abbreviation is defined in the figure legend or at the end of the table.



Executive summary

Background

The incidence of patient infection and colonisation with methicillin-resistant *Staphylococcus aureus* (MRSA) continues to rise in UK hospitals and poses a considerable socio-economic burden. Management of this problem includes screening to detect asymptomatic carriers and the use of various isolation measures to control its spread. There has been much debate about the rationale and cost-effectiveness of these measures. MRSA guidelines have been published but there was an urgent need for a systematic review to examine the evidence base for these recommendations.

Objectives

1. To review the evidence for the effectiveness of different isolation policies and screening practices in reducing the incidence of MRSA colonisation and infection in hospital inpatients.
2. To develop transmission models to study the effectiveness and cost-effectiveness of isolation policies in controlling MRSA.

Methods

- The search strategy covered the main subject areas addressed in the review: MRSA; screening; patient isolation; and outbreak control.
- Studies with economic data or analysis were included.

Data sources

- Searches of electronic databases MEDLINE (1966–2000), EMBASE (1980–2000), CINAHL (1982–2000), The Cochrane Library (2000) and SIGLE (1980–2000).
- Manual searches of the principal hospital infection journals to validate electronic database searches.
- No language restrictions were imposed.

Study selection

- Abstracts were appraised by two or three reviewers working together and selected if they

mentioned endemic or epidemic MRSA and an attempt at control in a hospital setting.

- Two investigators reviewed the full papers independently and extracted data where studies were prospective, employed planned comparisons using retrospective data or used isolation wards or nurse cohorting (designated nurses for the care of MRSA-affected patients).

Data extraction

The study period was divided into phases, where appropriate, and the following data were extracted:

- details of all populations under investigation
- details of patient isolation, screening and other infection control measures (e.g. eradication of carriage, antibiotic restriction, hand-hygiene, feedback, ward closures)
- information on outcomes (e.g. infection, colonisation, bacteraemia, death)
- details of potential confounders or effect modifiers including length of stay, antibiotic use, strain change, pre-existing trends, numbers colonised on admission, seasonal effects, staffing levels and aspects of study design that might introduce biases.

Authors were written to when isolation or screening policies, or their timing, were unclear.

Studies were excluded if isolation policies or timing of interventions remained unclear, or if the only outcomes reported were colonisations and screening policy was unclear or changed substantially.

Data synthesis

- Data were summarised in table form. Formal meta-analysis was considered inappropriate owing to heterogeneity in study design and patient populations.
- The strength of evidence in each study was evaluated by examining the study design, quality of data, size of effect and presence of plausible alternative explanations due to confounders and biases.

Modelling methods

- Stochastic and deterministic compartmental models were used to investigate the long-term transmission dynamics of MRSA.
- Hospital and community populations were considered, but all transmission was assumed to occur in hospitals.
- Models studied the impact of a fixed-capacity isolation ward.
- Local cost data were coupled to models to produce economic evaluations.
- Models were also used to address issues of statistical validity in publication and analysis bias.

Results: systematic review

- There were 4382 abstracts from which 254 full-article appraisals were made. Forty-six were included in the final review.

Study designs

- one prospective cohort cross-over study
- two prospective cohort studies with historical controls
- nine prospective interrupted time series (ITS) (three had prospective data collection but unplanned interventions)
- six prospective observational one-phase studies
- five hybrid retrospective/prospective ITS
- one retrospective cohort study with systematic data collection and the comparison decided on in advance of examining the data
- two retrospective studies with the comparison decided on before examination of the data
- eighteen retrospective ITS
- two retrospective observational studies.

Study interventions

- Eighteen studies described the use of **isolation wards**. Study durations ranged from 3 months to 15 years, and involved between 11 and 5345 MRSA cases.
- Nine studies described the use of **nurse cohorting (NC)**. Study durations ranged from 3.5 months to 4 years, and involved between 5 and 1074 MRSA cases.
- Nineteen studies described **other isolation policies**. Study durations ranged from 1 month to 9 years, and involved between 9 and 1771 cases.
- In nearly all the studies isolation was combined with at least one other simultaneous intervention.

Study settings

- Twenty-five studies were set in one or more entire hospitals, 20 were set in individual hospital units and one used survey data from multiple hospitals.

Quality of studies

- There were few formally planned prospective studies with predefined pre- and postintervention periods.
- Systematic assessment and adjustment for potential confounders was lacking.
- Regression to the mean effects and confounders were plausible threats to the validity of many studies. The predominance of unplanned retrospective reports suggests that reporting bias may be important.
- Statistical analysis was absent or inappropriate in all but two studies.
- There was no robust economic evaluation.

Results

- No conclusions could be drawn about the effect of isolation in one-third of studies. In studies with multiple simultaneous interventions it was not possible to assess the relative contribution of individual measures.
- Most others provided evidence consistent with reduction of MRSA. In half of these, the evidence was considered weak because of poor design, major confounders and/or risk of systematic biases.
- Two studies presented evidence consistent with immediate isolation reducing transmission.
- Stronger evidence was presented in the larger and longer time series, with large changes in MRSA numbers, detailed information on interventions and relative absence of plausible alternative explanations.
- There were six such studies:
 - (a) Three presented conflicting evidence of the effectiveness of **isolation wards** (with other measures) in reducing MRSA infection hospital wide: one reduced infection, one did not and one resulted in control for many years until a change in strain and/or an increase in the number of patients colonised on admission overwhelmed the institution.
 - (b) One presented evidence that **single-room isolation** with screening, eradication and an extensive hand-hygiene programme reduced MRSA infection and colonisation hospital wide.
 - (c) One provided evidence that **NC** in single rooms with screening and eradication reduced infection hospital wide. One paediatric intensive care unit study provided evidence that **single-room isolation** and patient cohorting in bays (with screening, feedback of infection rates and hand-hygiene education) reduced infection.

- It was not possible to draw any conclusions about the cost-effectiveness of the interventions because of the poor quality of the economic evaluative work presented. The costs included were not comprehensive – many items were omitted – and they were not consistent as the items included in the studies varied widely.

Results: modelling

- Equilibrium endemic prevalences of MRSA in hospitals with fixed-capacity isolation facilities were shown to be dependent on the detection rate of MRSA patients, the number of isolation beds available and the transmissibility of the organism.
- Improving either the detection rate or isolation capacity was shown to decrease endemic levels provided that the other was not the limiting factor.
- The final endemic level often depended on when the isolation ward opened, with ultimate eradication often possible only when the isolation ward was opened early.
- In many scenarios, long-term control failure occurred owing to saturation of isolation facilities as the numbers colonised on admission rose. However, even when such control failure occurred, the isolation ward delayed the rate at which prevalence increased and reduced the ultimate endemic level. Saturation of isolation facilities can be prevented by ensuring sufficient capacity.
- A paucity of reliable information on key parameter values hampered economic evaluations. However, under a wide range of plausible parameter values estimated independently, substantial savings could be achieved over 10 years compared with a policy of no isolation, provided that the burden of unused isolation ward capacity and staff time was not too great. Assumptions were made about the unused capacity on the isolation wards that had implications for the estimates of opportunity costs. Our assumptions possibly overestimated the opportunity costs. The opportunity costs in practice may have been less and would depend crucially upon what the alternative uses would have been and what would have been the cost of maintaining unused capacity. We lacked data to estimate these costs.

Conclusions

Implications for healthcare

- There was evidence that intensive concerted interventions that include isolation can substantially reduce MRSA, even in settings with a high level of endemic MRSA. Little evidence was found to suggest that current isolation measures recommended in the UK are ineffective, and these should continue to be applied until further research establishes otherwise.

Research recommendations

- Future research should concentrate on prospective planned comparisons, with predefined pre- and postintervention periods and systematic assessment and adjustment for potential confounders as necessary. Randomised controlled trials with cluster randomisation by hospital or specialist unit are one possibility. Consideration should also be given to other valid designs, including those based on prospective interrupted time series as, although they represent weaker designs, they may often be more feasible.
- Priority research questions include an examination of the effect of adequately sized isolation wards in hospitals with endemic MRSA; the effects of single-room isolation with an extensive hand-hygiene programme, screening and eradication; and NC, with screening and eradication. Study designs that permit the identification of the effects of both individual interventions and the effects of combined interventions should be considered.
- Attention should be paid in intervention studies to estimating the resources used in the intervention in a comprehensive way. Cost vectors can then be applied that are designed as far as possible to reflect the opportunity costs associated with the use of these resources.
- We recommend that future outbreak reports and intervention studies be written up in a standardised manner with full recording of interventions, outcomes and confounders to ensure that specific threats to validity are addressed. We have produced guidelines to facilitate this.
- An audit system that enables infection control teams to collect and use data on potential effect modifiers, alongside current MRSA surveillance systems, needs to be designed, piloted and evaluated. Evaluation should focus on the role of the system in planning interventions and interpreting their outcomes.

Chapter I

Introduction

Methicillin-resistant *Staphylococcus aureus* (MRSA) is now widespread in UK hospitals. The quarterly *Staphylococcus aureus* bacteraemia reports in the Communicable Disease Report (CDR) have charted an inexorable rise in the proportion of *Staphylococcus aureus* bacteraemias caused by MRSA – from 2% in 1991 to 42% in 2000.^{1,2} More recently, the publication of the MRSA bacteraemia rates from the first 6 months of the Department of Health's mandatory *Staphylococcus aureus* bacteraemia surveillance programme showed that the majority of English acute NHS Trusts are affected by MRSA, the London region having the highest rates.³ Management of MRSA aims to control the spread of infection, protect the most vulnerable patients and discourage the selection of even more resistant strains. However, the most effective approach to achieve these aims remains controversial. There is much debate about the effectiveness of specific interventions (which consist primarily of isolation of carriers, and sometimes contacts, in side rooms or isolation units). These measures impact on the patient and the hospital, so their benefit must be proven. Traditional narrative reviews attempted to assess the evidence available. The most recent is the report of a combined Working Party of the Hospital Infection Society, the British Society for Antimicrobial Chemotherapy and the Infection Control Nurses' Association revising earlier national guidelines on the control of MRSA in hospitals.⁴ The report categorised interventions according to the strength of the evidence, which showed that accepted practice was largely based on medical and scientific rationale and suggestive evidence, rather than on well-designed experimental studies. There was little research or mathematical modelling predicting outcome and resource use. It was against this background that the need for a formal descriptive and quantitative systematic review with epidemiological modelling was recognised and commissioned by the Health Technology Assessment Board.

This introductory chapter provides an outline of the epidemiology, growing antimicrobial resistance and pathogenicity of *Staphylococcus aureus* and

MRSA, the management strategies available, the findings of recent narrative reviews and the need for and aims of a systematic review.

Staphylococcus aureus and MRSA

Staphylococcus aureus is normally carried asymptomatically in the nares or on the skin of ~30% of the population.^{5,6} This percentage rises to ~50% in healthcare workers or hospital inpatients. Carriage is more common on skin that is broken, for instance if there is a cut, a sore or a rash such as eczema.

Staphylococcus aureus can cause problems when it gets the opportunity to enter the body. It may then cause local infection (abscesses, boils or infected wounds) or spread further to cause a more serious systemic infection such as septicaemia.⁷ The main route of transmission is through direct contact, via the transiently colonised hands of healthcare workers,⁸ although airborne and environmental transmission also occurs.⁹

MRSA are a heterogeneous group of *Staphylococcus aureus* strains that are methicillin-resistant and often multiply antibiotic resistant. They behave in the same way as methicillin-susceptible *Staphylococcus aureus* (MSSA), often causing harmless colonisation and sometimes causing infection. As for MSSA, transmission is mainly via direct contact.⁸ Studies have shown that 80% of staff who dress MRSA-infected wounds may carry the organism on their hands for up to 3 hours. However, this can be virtually completely eradicated by immediate washing with liquid soap and water after patient contact.^{10,11}

Whether MRSA are as virulent as MSSA was widely debated in the 1980s, but it is now generally acknowledged that some strains may be as virulent as MSSA.^{10,12-15} Some reports have indicated increased mortality and morbidity with MRSA, but it is not always possible to extricate the effect of other factors in this, such as delays in instituting appropriate therapy. Some case-control studies

have concluded that it is the severity of underlying disease in the patient with MRSA that predicts outcome.^{12,14–17}

Increasing antimicrobial resistance

Penicillin resistance in *Staphylococcus aureus* was reported soon after the introduction of penicillin for therapeutic use in 1941.¹⁸ By 1948, ~60% of hospital strains were penicillin-resistant¹⁹ and β -lactamase resistance had been described.²⁰ The introduction of other new antimicrobial agents in the 1940s and 1950s was usually followed by reports of resistance, so that by the end of the 1950s multiple antibiotic resistance was common in hospitals. For instance, at least 85% of all *Staphylococcus aureus* strains in a hospital in Seattle, WA, USA, in 1959 were resistant to penicillin and streptomycin, 60% resistant to tetracycline, 43% resistant to erythromycin and 28% resistant to chloramphenicol.²¹

The introduction of a penicillinase-stable penicillin, methicillin, in 1960 had a dramatic clinical impact on this deteriorating situation.²² However, naturally occurring methicillin resistance was reported shortly afterwards.²³ By the late 1960s, problems with increasing methicillin resistance in hospitals were being reported from various European countries,^{24–26} but the incidence of multiple antibiotic resistance was declining. The 1970s, described as the ‘decade of complacency’, was a period of decreasing multiple and methicillin resistance.²⁷ However, this calm was shattered in the late 1970s and early 1980s, first by an outbreak of methicillin- and gentamicin-resistant *Staphylococcus aureus* in a London hospital in 1976²⁸ and then by the advent of new epidemic strains of methicillin-resistant *Staphylococcus aureus* in the 1980s.

These strains, subsequently termed ‘epidemic MRSA’ (EMRSA), were different from those which had caused problems in the 1960s. For instance, most of their resistances were now borne on the chromosome, unlike the 1960s strains where most antibiotic resistance was plasmid-borne. The first of these EMRSA, EMRSA-1, was indistinguishable from a strain that had been responsible for earlier outbreaks in hospitals in Victoria, Australia.^{29,30} This strain caused major outbreaks in London hospitals before spreading beyond. Subsequently, other EMRSA came to the fore, pre-eminent ones being EMRSA-3, -15 and -16. EMRSA-16 is the current predominant strain in the UK. An early

report of an EMRSA-16 outbreak of 400 cases at a District General Hospital in Kettering reported that 79% of those affected had asymptomatic colonisation, usually of wounds, throat, nose and perineum.³¹ The remaining 21% were infected, but serious infections appeared relatively rare, although they included endocarditis, bacteraemia, osteomyelitis and orthopaedic prosthetic infection. Directly attributable mortality was reported to be <2%.³¹ Different strains may have different properties, including pathogenicity and potential to spread (epidemicity).³²

Since then, the next steps in growing antimicrobial resistance have been taken: glycopeptide intermediate-resistant *Staphylococcus aureus* (GISA) was reported from Japan in 1997, where over 80% of *Staphylococcus aureus* are MRSA.³³ GISA has since been reported in the UK, although still unusual.³⁴ These developments strike at the main therapeutic options for serious MRSA infections: vancomycin and teicoplanin. Although there are newer antibiotics with a role in the treatment of MRSA infections, such as linezolid,³⁵ resistance to these has also been reported and such antimicrobials may not be effective in serious life-threatening infections.³⁶ Consequently, there is concern that our main therapeutic agents against *Staphylococcus aureus* are in jeopardy and so there is an urgent need to curtail the spread of MRSA in hospitals. This concern extends to fear of the threat posed by MRSA strains with complete glycopeptide resistance caused by transfer of this resistance from glycopeptide-resistant enterococci (GRE) (increasingly common in specialist hospitals).³⁷

MRSA outbreaks are caused by transmission of pre-existing MRSA clones rather than the spontaneous emergence of resistance during antibiotic treatment. Broad-spectrum antibiotics such as cephalosporins or β -lactamase inhibitors may play a role in increasing such transmission and in amplifying MRSA populations when the organism is carried at a low level,^{38,39} but many confounding factors in the complex hospital environment make it difficult to evaluate the relationship between antibiotic use and the burden of MRSA.

Control of MRSA

The thrust of policies to contain the spread of MRSA has been determined by the need to protect vulnerable patients and safeguard our therapeutic options. As direct contact is the main route of transmission, the cornerstone of most MRSA

management has been rigorous infection control, in particular handwashing, and isolation of patients with MRSA in side rooms or units (with ward closures if spread is not curtailed).

MRSA control in England has gone through various phases, reflected in the national guidelines. These were first formulated in 1986⁴⁰ and revised in 1990⁴¹ and 1998.⁴ The initial approach was that described as 'search and destroy' with patients being screened for MRSA and affected patients being isolated in side rooms or, preferably, an isolation ward (IW).⁴⁰ In most settings, screening of all patients and healthcare workers (HCWs) was advised following one or more cases in a ward.

A growing endemic problem and overstretched infection control teams (ICTs) with little senior management support meant that the approach in later revisions of the national guidelines changed to a focus on protecting high-risk units in hospitals.⁴ This more flexible 'targeted' approach depended on the type of ward (i.e. the type of patient), the available isolation facilities and local experience of MRSA. Patients were stratified according to the level of perceived risk to them from MRSA: intensive therapy unit (ITU) patients, burns, vascular, orthopaedic and cardiothoracic surgery patients, for example, were regarded as 'high risk', general surgery, urology, dermatology and obstetric and gynaecology patients as 'moderate', general medical, acute care of the elderly and general paediatric patients as 'low' and long-stay elderly or psychogeriatric as 'minimal risk'. A range of management options were described for each level of risk, with increased requirement for isolation and increased intensity of screening the higher the vulnerability of the patients. It was recommended that in hospitals where MRSA is not endemic, the initial approach for all patients should be as for the high-risk group in endemic settings.

In the earliest phase affected hospitals aspired to establishing IWs, but rarely obtained resourcing for these. Consequently, isolation facilities have varied widely from side-room isolation, to cohorting affected patients in rooms or bays (with or without simultaneous cohorting of staff), to use of an IW. The latter ranged from dedicated MRSA wards to wards catering for infectious diseases generally, where MRSA patients might be cohorted and non-MRSA patients would be nursed in single rooms. The type of patient isolated varied from all those affected, whether colonised or infected, to contacts or new admissions awaiting

screening results, to those deemed 'dispersers' with uncontrollable secretions or widespread exfoliative skin conditions. As the 'search and destroy' approach waned, some hospitals ceased isolating affected patients, relying on universal precautions (gowns and gloves) to prevent spread. In addition, different institutions or units operate a variety of screening policies from targeted (e.g. only those admitted from nursing homes or with a past history of MRSA or transfers from abroad) or non-targeted (all admissions). Attempts may or may not be made to eradicate MRSA carriage from nose or skin using topical agents, such as mupirocin, chlorhexidine, povidone iodine or triclosan. Likewise, systemic eradication with rifampicin/fucidin may be attempted in certain circumstances. Normally, MRSA control policies are part of a wider framework of infection control policies in a hospital, which may encompass handwashing education programmes as well as antibiotic policies and feedback of MRSA rates to clinical staff. Clearly, multiple combinations of policies to control MRSA may ensue: isolation with or without decontamination, with or without a handwashing decontamination programme, with or without an antibiotic policy. Beyond this, the extent to which application of these policies is policed is likely to vary.

Outcome of control measures

There is much debate about the effectiveness of individual control measures and, in view of the disruption caused by screening and isolating patients, whether such measures are worthwhile. In addition, isolation can have deleterious effects in some groups of patients, such as confused elderly patients.⁴² Some have therefore argued that the effects of MRSA do not warrant infection control overriding many other aspects of health care, especially in settings without sufficient isolation facilities. Much of the debate has been summarised in several reviews.^{4,40,41,43-47}

The most recent revision of the guidelines for control of MRSA infection in hospitals⁴ concluded that control measures, especially isolation units, have an impact and that the costs of not controlling MRSA [e.g. extended length of stay (LOS), theatre closure, disruption of routine activities, antibiotic budgets] are higher than those of control (isolation unit, eradication therapy, cleaning, etc.). Costs are frequently unreported, but where they are, they are often the costs of control (ICT, IW, laboratory, eradication therapy, environmental cleaning) plus some of the directly

attributable cost of MRSA infection such as glycopeptide treatment.⁴⁸ Other directly attributable costs (e.g. hotel costs due to extended LOS) are often not given, nor are other costs which may be difficult to assess or quantify, such as those associated with theatre closure or disruption of routine activities. Although the most up-to-date review available, the report was not intended to be a systematic review, quantitative or descriptive. It noted the difficulty of estimating the cost-effectiveness of interventions where the successful outcome is an event not occurring and that epidemiological modelling would help to fill this gap. Recent costings for one UK Trust in the event of uncontrolled MRSA indicate doubling of the entire antibiotic budget alone.⁴⁸

An American review reported that the 'intensity' of isolation measures was unrelated to the degree of control achieved.⁴³ A more recent narrative review⁴⁴ also reported this, and that more relaxed policies may succeed, paradoxically, where stricter policies may fail and vice versa. Apparent success may coincide with other measures being introduced such as mupirocin, antibiotic policies or intensive ward-based education, feedback of MRSA rates and handwashing. This makes it hard to know which element of any strategy is most influential, although the recent UK ICT MRSA questionnaire study⁴⁹ found that the performance of inter-hospital transfer screening from abroad, fewer inter-hospital transfers and delays in identifying patients and absence of mupirocin resistance were significantly related to success of control, that is, reduction in incidence. It has been suggested that the behaviour of the individual MRSA strain may be the key factor⁵⁰ and, if so, this would make it hard to generalise from one strain or setting to another. The review⁴⁴ also noted that there are virtually no randomised control trials (RCTs). Unlike studies of non-infectious disease, where patient outcomes are independent, RCTs for infectious disease control are more difficult to carry out, requiring cluster randomisation between units in a large enough number of hospitals to give a trial adequate power. Indeed, there is a general lack of formal studies, in part because one cannot set out to control an outbreak until there is one. The onset of an

outbreak also demands that the problem be solved rather than conduct research to determine the best method of control. Furthermore, outcome measures, in addition to interventions (details of which may be sparse), vary widely, infection and mortality rates may be unstated, costs may not be reported and what happens once successful control measures are discontinued may not be mentioned.⁴⁴ Indeed, a recent mathematical modelling of the transmissibility of MRSA indicates that what may look like an extremely successful result from a package of control measures may be entirely due to chance. It also shows, however, that even small (10%) increments in handwashing frequency may have major effects on MRSA prevalence.⁵¹

Aims of the systematic review

A formal descriptive and quantitative systematic review with epidemiological modelling would build on the work of the Working Party by providing an estimate of the cost-effectiveness of different management strategies, in different settings, including those recommended by the Working Party report. At the level of the ward, stochastic (chance) events may dominate observed patterns, so that long-term monitoring may be required to demonstrate the effectiveness of any intervention empirically.⁵¹ Stochastic transmission models would greatly aid interpretation of such data. The initial objectives of the review are to:

1. provide a full descriptive review of different isolation policies used in the management and control of MRSA in hospital
2. examine the evidence for the effectiveness of different isolation policies in reducing the incidence of MRSA colonisation and infection
3. provide stochastic transmission models for a range of MRSA control options (including those recommended by the Working Party) for various patient groups, MRSA types, virulence and background levels, estimating clinical effectiveness (cases of MRSA infections and deaths avoided) and costs (costs of control versus costs of cases avoided)
4. identify future research priorities.

Chapter 2

Threats to valid inference

Introduction

In this section we summarise the major threats to the validity of inferences drawn from studies in this review. These threats have been identified from the full study appraisals and theoretical considerations. We present qualitative and, where possible, quantitative assessments of the magnitude of the threats.

The intention is to summarise what we consider to be the most important threats, rather than provide an exhaustive list. We present a detailed list of potential confounders, sources of bias and measures taken to prevent or adjust for these for the individual studies in the review. The section 'Major cofounders and bias' in the long summary tables in Appendix 3 then summarises what we consider to be the most important threats to making valid inferences from these studies.

In this section we also briefly present recommendations for obviating these threats. These recommendations inform Appendix 5, which provides recommendations for conducting and reporting formal studies and reporting outbreaks.

It should be noted that many of the pitfalls associated with making inferences about interventions in MRSA studies are common to many quasi-experimental studies, and more specifically to other areas of epidemiological research.⁵² However, there are important differences with MRSA studies, such as changing patient populations, evolving strains and transmissible pathogens. For this reason, it is valuable to consider the specific threats relevant to the studies in this review. As almost all of the studies of relevance to this project come from interrupted time series (ITS) designs (where outcome measures from usually one or two populations are recorded at a series of time points, but interrupted by an intervention), problems specific to such designs are the main focus of this chapter.

Terminology

We have adopted the terminology of Cook and Campbell,⁵² who categorise threats to valid inference under four broad headings:

1. Internal validity

The degree to which observed changes in outcomes can be inferred correctly to be caused by the intervention.

2. Construct validity

The extent to which changes in outcomes can correctly be inferred to be caused by specific presumed mechanisms related to the intervention (i.e. particular constructs), and not by some unintended by-product of the intervention. For example, in an intervention to control MRSA by isolating patients, the measured effect may be due to an inadvertent increase in staff hand hygiene, for example, if staff wash their hands more when they know they are part of a study. While the intervention could still be said to have caused any resulting reduction in cross-infection, it would not be correct to presume that the mechanism by which this was achieved was related to the patient isolation.

3. Statistical conclusion validity

The extent to which valid conclusions can be made about the likelihood of the observed changes occurring by chance alone, rather than being due to the interventions.

4. External validity

The extent to which inferences about causal relationships can be validly generalised to different populations, settings and times.

In the following sections we consider each of these classes of threats in turn, discussing the major threats and how they can be avoided.

Internal validity

Major threats

Confounding factors/history

Causal inferences from MRSA studies based on ITS designs are at risk of reaching false conclusions if other changes, not related to the interventions of interest, but affecting the transmission and persistence of MRSA, occur at about the same time.

Many factors have been suggested to influence the spread of MRSA. These include staffing levels,⁵³ carer behaviour (e.g. handwashing),⁵⁴ staff–patient contact patterns,⁵⁵ antibiotic consumption,⁵⁶ ward cleaning; handwashing agents used;⁵⁷ LOS,⁵¹ patient crowding/bed occupancy,⁵⁸ MRSA clearance therapy; and properties of the organism itself.⁵⁹ In ITS studies, such threats can best be dealt with by recording data regarding these potential confounding factors and by adjusting for them, if necessary, in the statistical analysis of the data. Concurrent data from a control group not subject to the intervention but likely to be subject to many of same changes can also eliminate many of these threats.

Trends/maturation effects

Where there are pre-existing trends in outcome measures prior to interventions, there is a risk that observed changes in MRSA are falsely attributed to interventions. Conversely, a trend could mask a true effect of an intervention (e.g. if MRSA numbers were increasing prior to the intervention). Such threats are greatest when outcome data are presented as only two data points: one pre- and one postintervention. They can be avoided by presenting multiple pre- and postintervention measurements so that any trends are made apparent. When such trends exist, appropriate analysis of the time series data can be used to determine what effect the intervention had. However, lack of trend is no indication of the failure of an intervention: the intervention might have prevented an increase postintervention.

Seasonal effects

For short ITS studies, seasonal effects may provide alternative explanations for apparent treatment effects. A number of plausible mechanisms could explain seasonal influences on MRSA outcome data. For example, there may be more imported MRSA cases in winter months as more elderly patients are admitted, resulting in more secondary cases. Similarly, seasonal changes could be mediated by changing staffing levels (perhaps due to illness) or changes in bed occupancy.

Such threats can also be reduced by appropriate recording of possible confounders, appropriate analysis of time series data and by obtaining longer time series or more time series with the intervention occurring at different times.

Detection

Changes in measurement of outcomes also present threats to valid inference. Such changes may either be due to changes in procedures for screening,

culturing and identifying MRSA colonisation and infection, or to changes in the way standard procedures are carried out. Examples would include improvements in the skill of staff or unconscious expectations of staff collecting and analysing isolates.

Such threats may be reduced by adopting procedures that are standardised as far as possible, and ideally by blinding outcome assessors to the details of the study. Colonisation data are likely to be particularly vulnerable to changes in screening practices. When screening is not carried out systematically, infection data should provide reliable outcome data if consistent criteria for defining infections are applied and there is a constant intensity of microbiological sampling. Bacteraemias are likely to provide one of the most reliable outcome measures because most clinicians will take blood cultures from patients presenting with features of sepsis. For other types of infections there may be expected to be more variability in sampling practice.

Attrition

Since the patients in different phases of an ITS study in a hospital population are continually changing with time, attrition (loss of patients from the study) may seem to be unimportant, as loss to follow-up is occurring all the time, for all patients. However, changing patient LOSs can be thought of as an attrition effect since patients may drop out of the study at different rates in different phases. For example, if infections are less likely to be detected during hospitalisation for patients with shorter lengths of stays, then a trend for a decreasing LOS could well give a spurious appearance of a reduction in the infection rate.

Measures that could be taken to prevent such bias include follow-up of discharged patients in the community and appropriate analysis of outcome data that takes account of such an effect. Such an analysis may include methods that explicitly account for changes in LOS, such as survival analysis, where the time until a patient acquires MRSA is modelled.

Selection

If patients in different phases of an ITS study have different characteristics, the ability to draw valid conclusions about an intervention will be compromised. Such differences in patient mix may be related, for example, to seasonal effects or to changes in admission and/or discharge policies (when these are not part of the intervention) or, in

the case of longer time series, to long-term changes in provision of healthcare.

Again, such threats can be identified and avoided by recording appropriate patient characteristics. Appropriate analysis of patient-level data may be required to adjust for such effects.

MRSA strains

MRSA comprises a heterogeneous group of organisms, which are constantly evolving. The impact of changing properties of the MRSA strains themselves represents perhaps one of the hardest factors to assess, as very little is known about what causes one strain to spread or persist more than another.

The threat of changing strain properties is usually less plausible as an explanation for reductions in MRSA than it is for increases. This is because, if all other selective forces operating in a hospital are equal, evolutionary forces could be expected to select for more transmissible or more persistent strains rather than the opposite (the opposite process could theoretically occur in sufficiently small populations, but in settings with a large number of cases this is not a very plausible explanation for observed reductions in MRSA). However, if a substantial proportion of MRSA cases are colonised on admission, and there are changes in the strains brought into a hospital, then this could provide a plausible explanation for observed reductions in the transmission rate per source. For example, in some countries, such as the USA, Australia and New Zealand, there are MRSA strains that appear to spread well in the community.⁶⁰ If such strains spread less well in hospitals than existing hospital strains, the rise of these strains in the community could result in an overall decrease in the transmission rate from MRSA colonised individuals in the hospital. This would occur without other interventions and would be due only to the different properties of the community-acquired strain being brought into the hospital.

The threat of changing properties of strains is rendered less plausible when genotypic or phenotypic typing data suggest that MRSA isolates belong to a single or to closely related clones. However, all such typing methods are imperfect and may not necessarily detect important phenotypic changes, so such threats cannot be entirely ruled out. Furthermore, we do not have a reliable transmissibility or virulence marker for MRSA, so current typing systems may do little to help in the interpretation of observed changes in transmission rates and the incidence of disease.

Other ecological interactions

In certain settings, more complex ecological interactions may also be important. For example, in neonatal units interactions with other *Staphylococcus aureus* strains could influence outcomes as infants are routinely colonised with *Staphylococcus aureus* within a few days of birth.

Some studies have suggested that competition between different *Staphylococcus aureus* strains and between different bacterial species may be important.^{61,62} However, generally such effects seem to us to require a high level of coincidental circumstances in order to provide explanations for reductions in transmission over short timescales outside specialist units.

Regression to the mean and reporting bias

When interventions under investigation are made *because* of unusually high MRSA levels, there is a risk that subsequent reductions in MRSA levels will be falsely attributed to the interventions. This effect can be expected to occur when MRSA levels are fluctuating about a mean (as they may be expected to do in a setting with stable endemic MRSA). In such situations, periods with unusually high (or low) MRSA levels would be expected to be followed by periods with lower (or higher) MRSA levels even in the absence of any intervention. In other words, abnormal MRSA levels are expected to regress back to an equilibrium or mean level.

Reporting bias is usually assumed to result from authors' and journals' preferences for publishing positive results. That is, successful interventions are more likely to be reported than those which are unsuccessful. The amount of bias that results depends both on the amount of variation there is to select from, and the strength of the selection (i.e. how large a change must be observed before authors consider a result worth reporting or how much more likely a positive result is to be reported than a negative result). All types of studies may be expected to be vulnerable to reporting bias to some extent. However, unplanned reports of the effects of interventions are particularly vulnerable due to (i) the large amount of variation that can be expected to occur owing to the stochastic nature of epidemic processes and (ii) the very large pool of data from which to draw outcomes to report (i.e. all outbreaks or situations with endemic MRSA).

If regression to the mean effects in ITS studies results from the non-random selection of the first period in two-phase studies, reporting bias can be considered to be the extension of the non-random selection to both phases.

To avoid regression to the mean effects, decisions to intervene should not be based on recent levels of the outcome data. To prevent reporting bias, authors (and editors) should not be influenced by the outcome data in their decision to report (or publish) the results. For both retrospective and prospective studies this means that the comparisons to be made should be decided on without knowledge of outcome data for both pre- and post-intervention periods for ITS studies.

Reports of longer time series with larger numbers of MRSA cases may also be expected to be less at risk from reporting bias as the amount of variation to select from will be much lower, with the systems being better approximated by deterministic processes (although stochastic fluctuations will still be important, as is shown in Chapter 5). For larger studies, journals may also be less influenced by the reported statistical significance of results in their decision to publish.

Assessing reporting bias and regression to the mean

Reporting bias and regression to the mean effects are types of bias that are difficult to assess owing to the unknown strength of the selection processes. However, we can use simulation studies to examine the size of the errors that may be expected to result from different degrees of bias. *Figures 1–4* present results of such simulations, using a stochastic model of transmission in a 20-bed hospital ward over a period of 2 years. This 2-year period is divided into two periods of 1 year each, referred to as phase 1 and phase 2, and we consider an intervention **that has no effect** to occur at the start of phase 2.

The crucial point is that this division into phases is entirely arbitrary. All differences between the phases are due to stochastic variation and bias in the process of reporting the outcome data. Effectively, we are considering the situation where the null hypothesis is true (intervention has no effect) and looking at how biases can result in this hypothesis being erroneously rejected (falsely attributing an effect to the intervention).

Simulation details

We performed 1000 simulation runs in each of three scenarios: high, medium and low transmissibility (corresponding to a basic reproduction number, R_0 , of 0.5, 1 and 2, respectively, which defines the average number of secondary cases caused by a primary case in a susceptible population).

The transmission model used for these simulations was based on a previously described host–vector model where the transiently colonised hands of carers constituted the vectors responsible for spreading the organism.⁵¹ In the present case, however, no explicit assumptions about transmission routes were made, and carers were not included in the model. New cases were assumed to arise according to the mass-action assumption, where the rate of acquisition is proportional to the ward prevalence. This model is still, nonetheless, consistent with the assumption of hand-borne transmission.

The organism was assumed to be introduced at a constant rate, with each patient having a probability of 0.01 of being colonised on admission. For each simulation run, after an initial ‘burn-in’ period lasting for a simulated period of 1 year (which ensured that the results did not depend on arbitrarily chosen starting values), 2 years of simulated data were generated. Over this time nothing in the model changed, but the outcome data were divided into consecutive 1-year intervals (phases 1 and 2). All variation in the course of epidemics within each of the three scenarios at this stage was due to stochastic effects.

Outcome data were then obtained by selecting from these (unbiased) random simulations by imposing two types of bias. We first considered bias arising from the non-random selection of data from both study phases. To do this we ranked all simulation runs in order of the size of reduction in prevalence between phases 1 and 2, and selected the 20, 10, 5 and 1% of runs with largest reduction between phases. Second, we considered bias arising due to the non-random selection of phase 1 data alone.

This was achieved by ranking all 1000 simulation runs in order of the mean prevalence in phase 1, and selecting the 20, 10, 5 and 1% of runs with the highest phase 1 prevalences. This simulates regression to the mean effects, which can be expected when interventions are made in response to high MRSA levels.

Simulation results

Figure 1 shows a single simulation run from the intermediate transmissibility scenario ($R_0 = 1$). This run was selected at random from the 1% of runs with largest reduction in prevalence between phases 1 and 2, and therefore illustrates how reporting bias can result in misleading conclusions. If such a pattern of spread were observed in practice, the reduction in prevalence in phase 2

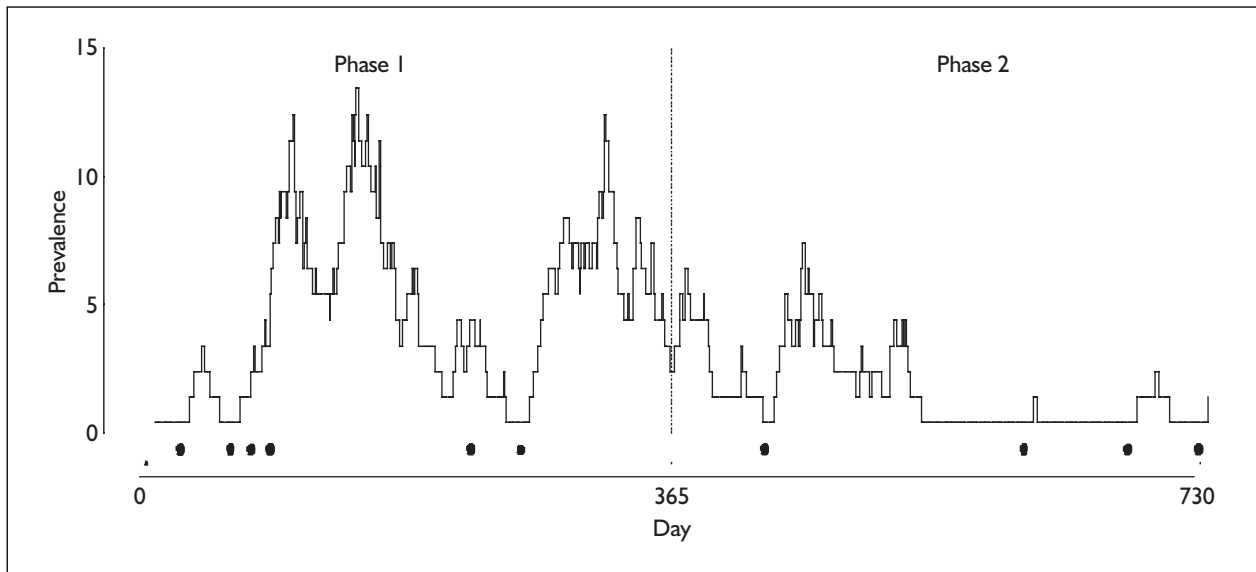

FIGURE 1 A single simulation run from a stochastic hospital epidemic model, indicating the ward-level prevalence over 2 years. An intermediate level of transmissibility was assumed ($R_0 = 1$). There was no change in parameters over the period, and the division into two 1-year phases is arbitrary. Patients colonised on admission are indicated by dots above the x axis.

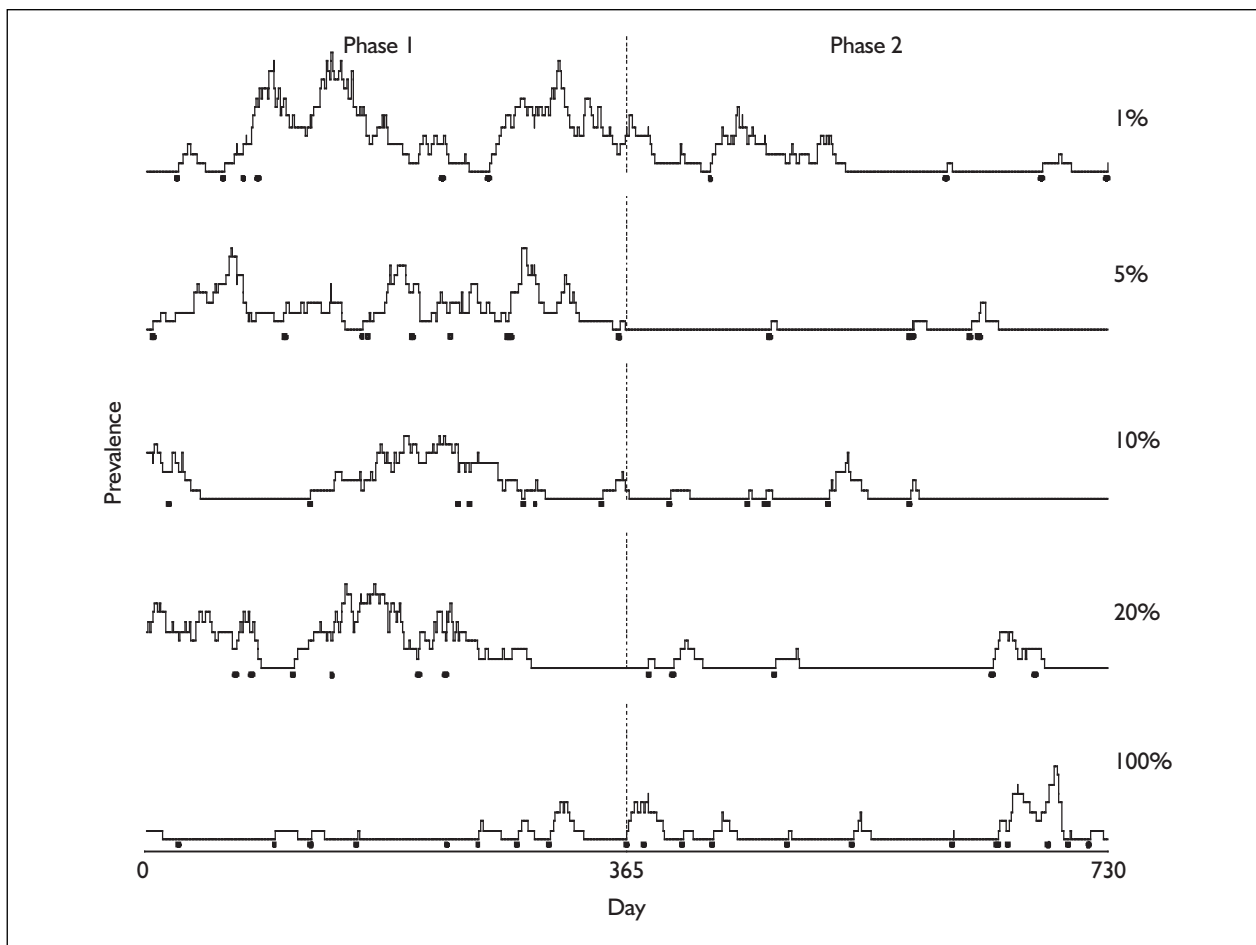

FIGURE 2 Reporting bias: five simulations from the stochastic epidemic model under the assumption of intermediate transmissibility ($R_0 = 1$). All runs used the same model parameters, and these did not change between phases. Selection bias increases with the higher graphs. The top graph, for example, shows randomly selected simulations from the 1% of runs with the largest reduction in prevalence between phases 1 and 2. The bottom graph shows a run randomly selected from the entire set of 1000 simulation runs.

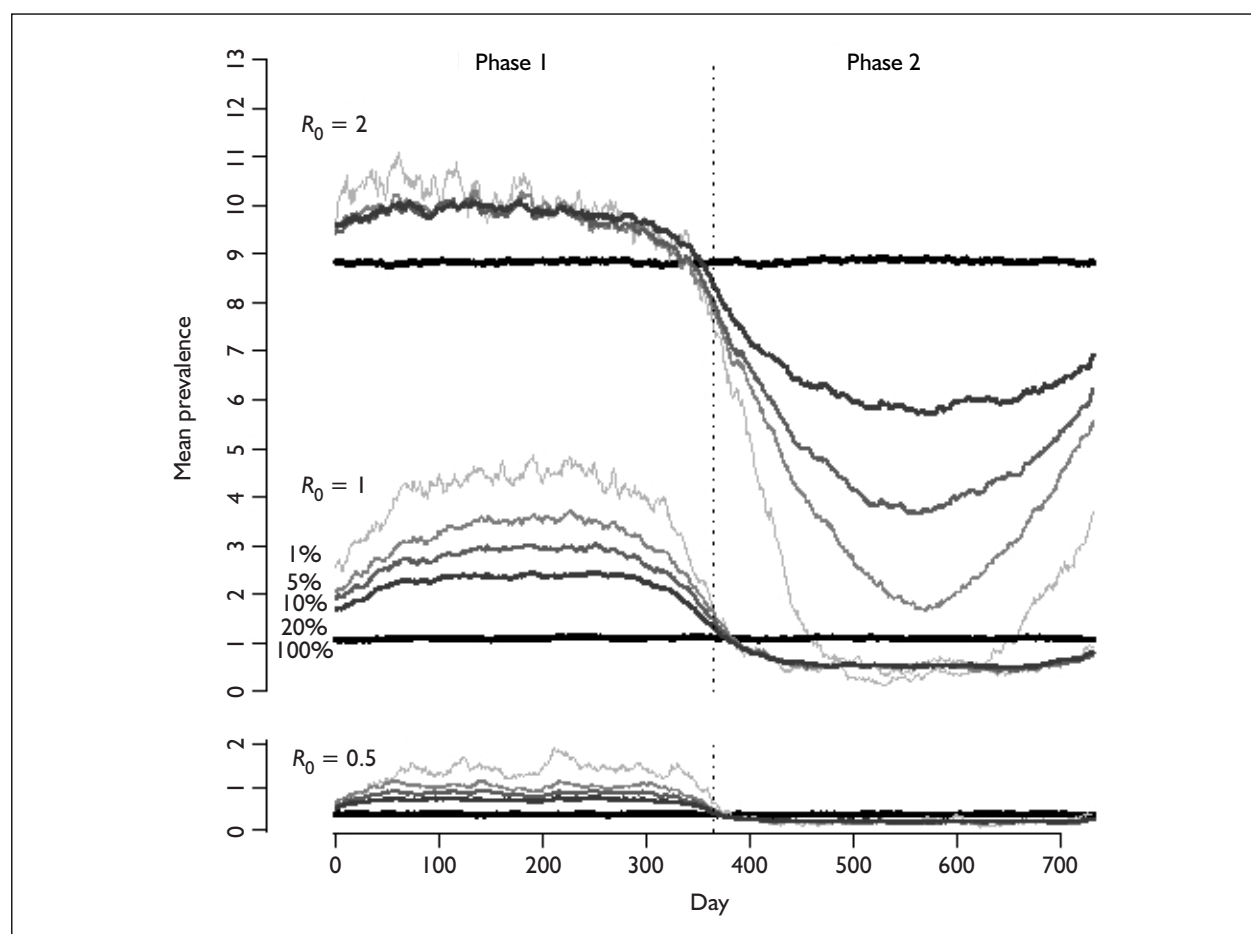

FIGURE 3 Reporting bias: means of simulations for three levels of transmissibility ($R_0 = 0.5, 1$ and 2). Simulation details are described in the text. Means are based on 1000 simulation runs for the heaviest (100% line), and all runs below the 20th, 10th, 5th and 1st percentiles of these 1000 simulations. Percentiles were calculated by ranking simulation runs in decreasing order of the reduction in prevalence between phases 1 and 2.

might be attributed to the intervention. In fact, the intervention here makes no difference and the reduction in transmission is due entirely to stochastic effects.

Figure 2 shows this simulation run together with other simulations selected at random from the 5, 10 and 20% of runs with the largest prevalence reduction. The bottom graph (labelled 100%) shows a simulation run selected at random from the complete set of 1000 simulation runs (i.e. without bias). All five graphs are outputs from exactly the same model (intermediate transmissibility, $R_0 = 1$) with the same parameter values, and the variability can be attributed to chance effects alone. These graphs show that very large biases can result if there is a tendency to report only successful interventions. For all four runs where selection bias is operating (the top four graphs) naïve interpretations of the outbreak reports would be likely to mistakenly attribute an effect to the intervention. In contrast, the

randomly selected run from the whole set of simulations appears to show an effect of the intervention in the opposite direction, although again this is just due to chance.

Figure 3 shows the means of all such simulations in Figure 2, together with those from the low and high transmissibility scenarios ($R_0 = 0.5$ and 2 , respectively). The heaviest (100%) lines represent the means from all 1000 simulation run under each of the three scenarios. The mean of all 1000 simulations does not change with time, showing that there are no systematic differences between phases 1 and 2. Hence, although there are reductions or increases between phases in individual runs, on average there are no differences. Therefore, if sampled at random, such outbreak reports would allow a fair assessment of the intervention.

Once reporting bias is introduced, the picture changes dramatically. If only some fraction of

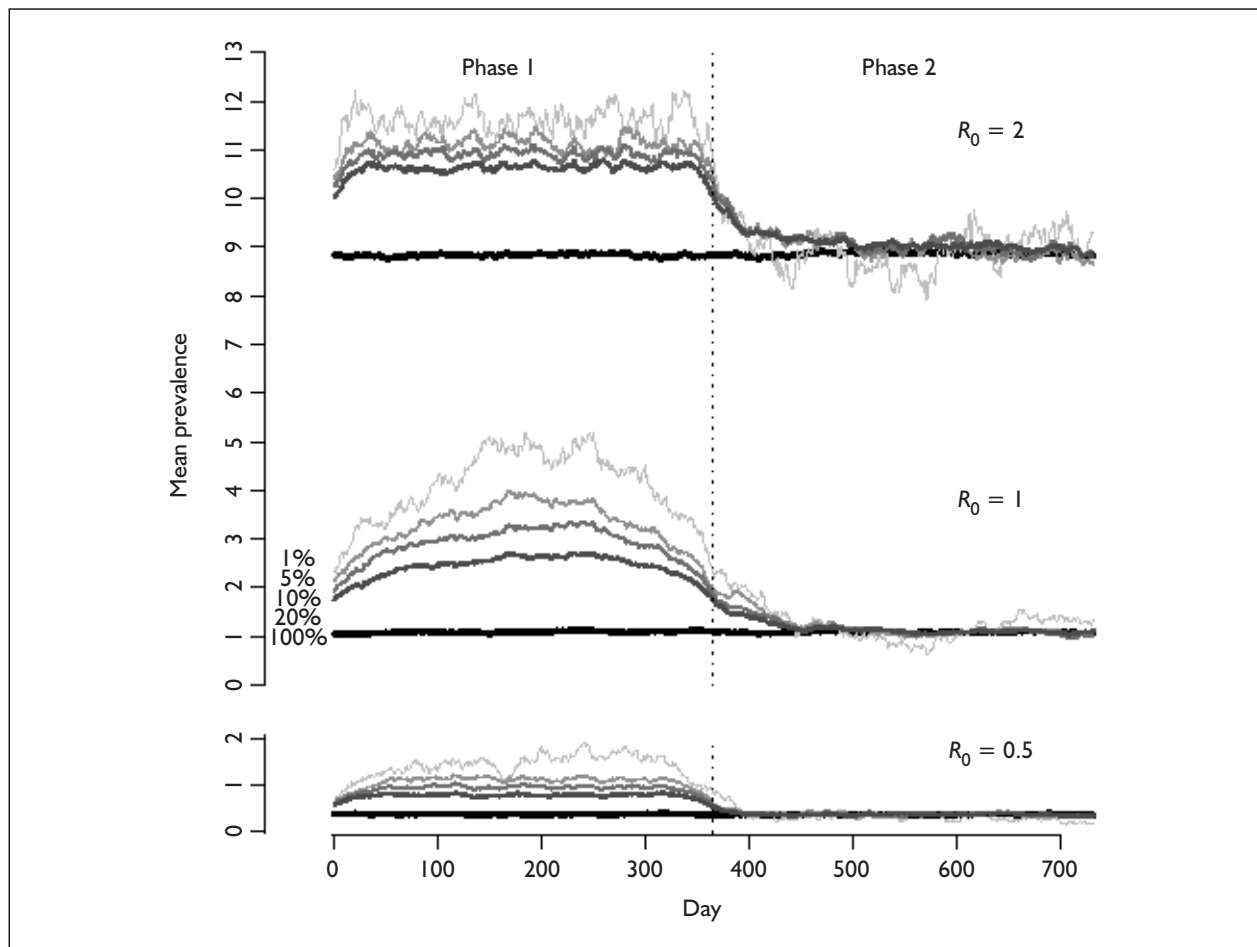

FIGURE 4 Regression to the mean: means of simulations for three levels of transmissibility ($R_0 = 0.5, 1$ and 2). Simulation details are described in the text. Means are based on 1000 simulation runs for the heaviest (100% line), and all runs below the 20th, 10th, 5th and 1st percentiles of these 1000 simulations. Percentiles were calculated by ranking simulation runs in decreasing order of the reduction in prevalence in phase 1 only.

those outbreaks with the highest reductions in MRSA are reported, very large changes in the means are seen under all three scenarios and all four levels of reporting bias considered (1–20%). In other words, if such reporting bias is operating, there is a very large risk that effects will be falsely attributed to the intervention. Furthermore, these results suggest that even very large effect sizes could be due to reporting bias in this type of study. The potential for bias is particularly large because of the serial correlation of the data and the importance of stochastic fadeouts: if the ward prevalence falls to zero, then there are no sources for future transmissions (until a colonised patient is admitted). The importance of the bias also increases with increased transmissibility, so that reports of interventions when such interventions will be most important are vulnerable to the most bias.

Figure 4 shows the mean prevalences taken from the same set of 1000 simulations for each of the

same three transmissibilities. The only change is in the way in which the simulation runs reported are selected. In this case, bias is assumed to operate only on phase 1 data, and is intended to mimic regression to the mean effects (percentiles were calculated by ranking all 1000 simulation runs in decreasing order of the mean prevalence in phase 1 only). Thus the faint 1% line represents the mean in the 1% of runs with the highest phase 1 prevalence. This figure therefore simulates bias that arises when interventions are made only **because** of high MRSA levels. This figure shows that if interventions are made only because of unusually high MRSA levels, then even if these interventions have no effect, substantial reductions in MRSA can be expected, and naïve interpretations of the data might again incorrectly attribute these changes to the intervention. The simulations show that the resulting bias can be large in all scenarios considered and therefore represents a major threat to making valid inferences about the efficacy of interventions aimed

at reducing MRSA spread. Again, the magnitude of the bias is greatest when transmissibility is highest, that is, when outcomes may be expected to be most likely to be reported.

Given that control programmes are frequently changed when MRSA levels increase, and that there is a natural tendency to report successful interventions, we believe that these two biases are likely to have a profound influence on published literature. Clearly, when such large biases are operating, outcome data cannot be considered to provide a basis for making reliable inferences about the effects of interventions.

Construct validity

Attributing changes to specific aspects of an intervention requires that unintended consequences of the intervention (that may affect MRSA outcomes) are ruled out. For the studies in this review, the most plausible of these threats arise due to Hawthorne effects.

Hawthorne effects occur when subjects in a study alter their behaviour as a result of being observed.⁶³ For example, carers may pay additional attention to hand hygiene if they know they are part of a study even when this is not targeted by the intervention. Similarly, carers' changing expectations in different phases of a study may cause (unconscious) changes in behaviour with time.

Measures that can be taken to protect against such effects in ITS studies include blinding of carers to different phases of the study (or even to the fact that there is a study); using retrospective data; and recording and adjusting (when necessary) for observed changes in carer behaviour (such as handwashing frequency and technique and patient contact rates).

Statistical conclusion validity

In ITS and before-and-after studies, testing the statistical significance of results requires making an assessment of how likely the observed changes, or changes more extreme than those observed, would have been under the assumption that the intervention had no effect. The probability of obtaining results at least as extreme as those observed under this null hypothesis is known as the p -value. The smaller the p -value, the less plausible it is that the results would have been

obtained if the intervention had no effect. Formal approaches to hypothesis testing require specifying a significance level (usually denoted by the symbol α). If p -values smaller than the value chosen for α are obtained they are taken as evidence for rejecting the null hypothesis. Conventionally (and arbitrarily) in many areas of research the value of α is taken as 0.05, and authors describe p -values smaller than 0.05 as being 'significant'. (Sterne and Davey Smith provide a recent discussion of the limitations and pitfalls associated with this approach to inference, even when the method is correctly applied.⁶⁴)

Two types of error are possible in such tests: rejecting the hypothesis that the intervention had no effect when this hypothesis is true (a Type I error) and failing to reject this hypothesis when it is false (a Type II error). The chance of making a Type I error when the null hypothesis is true is specified by the chosen α -value if an appropriate test is used. The chance of making a Type II error is known as the power of the study and will depend on the size of any effect resulting from the intervention. In conducting such hypothesis tests, it is accepted that erroneous conclusions will inevitably result with some probability, but that it is at least possible to assess the chance of making them under the different hypotheses.

Choice of statistical model

As with all statistical tests, calculating the chance of results at least as extreme as those observed on the assumption that the intervention had no effect requires choosing an appropriate statistical model for the data. Inappropriate choice of model has the potential to result in systematic errors when making inferences about the effects of the interventions, and therefore represents an important threat to the validity of any statistical conclusions.

The fact that MRSA is infectious immediately rules out a large number of statistical methods widely used in conventional, non-infectious disease epidemiology. The reason is that such methods, which include the commonly used Pearson's chi-squared and Fisher's exact test, assume that individual outcomes are **independent**. If this independence assumption were true, the chance of one patient acquiring MRSA would have to be unaffected by whether or not other patients in the study population harboured the organism. When the study patients inhabit the same hospitals or wards, this assumption is clearly untenable. Results obtained using such methods are therefore expected to be unreliable on purely theoretical grounds.

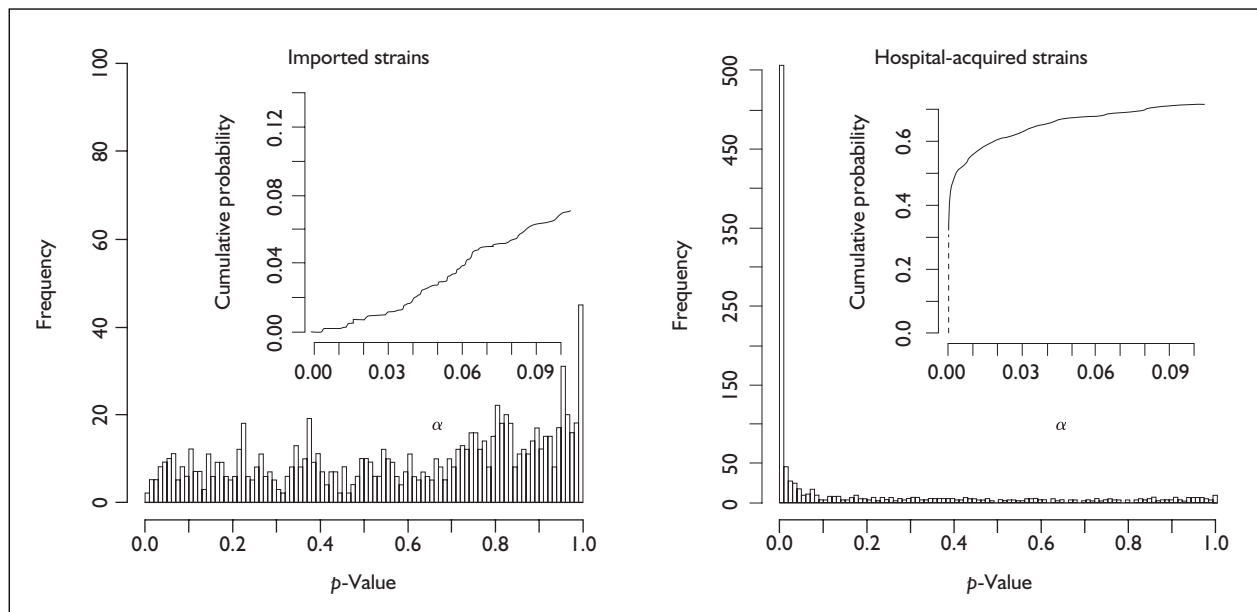

FIGURE 5 Distribution of p -values obtained by applying chi-squared tests to simulated data for imported and hospital-acquired cases of colonisation with a nosocomial pathogen. Tests were applied to 1000 simulated data sets generated by a stochastic hospital epidemic model that assumed patient-to-patient transmission with an intermediate level of transmissibility ($R_0 = 1$). Simulated data were arbitrarily divided into two 1-year periods, and the tests used to determine if differences in incidence were 'significant'. See text for full details. The inset shows the probability of obtaining p -values less than or equal to the α -value specified on the x axis. This corresponds to the chance of falsely rejecting the hypothesis (at the specified α -value) that the intervention had no effect (a Type I error).

Assessment of inappropriate statistics

To estimate the size of the error resulting from such use of inappropriate methods, we again used a simulation model of a ward-based epidemic to synthesise data. Since the process from which the data are created can be known with certainty, this approach allows us to assess how well the statistical methods perform.

Simulation details

Data were created using the same 20-bed single-ward model described above, with the same three scenarios: high, medium and low transmissibility (corresponding to a basic reproduction number, R_0 , of 0.5, 1 and 2, respectively). We again simulated a setting with endemic MRSA, where each patient had a probability of 0.01 of carrying MRSA on admission. MRSA transmission was simulated for 2 years (after an initial 'burn-in' period of 1 year), and the outcome data again arbitrarily divided into two 1-year phases. The outcome data included the incidence of cross-infections in each of the two phases, the numbers colonised on admission in each phase and the total number of patients discharged in each phase. We created 1000 such synthetic data sets under each of the three scenarios. For each data set we calculated Pearson's chi-squared test statistic (with Yates's continuity correction) for the 2×2 table where cell counts corresponded to the number of

patients acquiring, and the number not acquiring, MRSA in each phase of the study. When any of the cell counts were <5 , the chi-squared test performs badly, and instead we estimated the p -value using a Monte Carlo approach as described elsewhere.⁶⁵ We then repeated this analysis with cell counts corresponding to the number of admitted patients importing and not importing MRSA to the ward in each phase. Since, by assumption, each patient had an independent chance of importing MRSA to the ward, we expected the test to perform adequately in this case. All statistical analyses were carried out using R version 1.4.1.⁶⁶

Results are presented in *Figure 5*. For the test to perform well, the inset graphs showing the cumulative probability of incorrectly rejecting the null hypothesis (i.e. making a Type I error) as a function of the α -value should be close to a straight line through the origin with a gradient of one. The figure shows that, as expected, the test performs well for the colonised on admission data (imported cases). In fact, the test is slightly conservative, erroneously rejecting the null hypothesis of no difference between phases slightly less often than the α -value specified on the x axis (for example, for a conventional α -value of 0.05, the null hypothesis is rejected about 4% of the time instead of 5%). For the transmission data (hospital-acquired cases), however, the test

performs extremely badly. For example, the null hypothesis would be rejected at the 5% significance level (p -values <0.05) over 60% of the time. Even if α is taken as 0.01, Type I errors are made over half the time. Similar results were obtained in the other two scenarios, with p -values <0.05 being obtained in about 30 and 50% of simulations under the low and high transmissibility assumptions, respectively.

Because the test performs so badly it cannot be considered to provide any meaningful assessment of the statistical significance of the results and we do not report results of such tests in the studies in this review. Similar approaches, such as Fisher's exact test, can be shown to have the same problems.

More appropriate models

More appropriate choices of models fall into two broad classes: (i) mechanistic models, which seek to capture the structure of the data based on an understanding of the transmission process and (ii) models which try to describe the statistical correlations in the data, without attempting to provide mechanistic explanations for such correlations.

Most analyses of infectious disease data have adopted the former approach.⁶⁷ However, analysis of nosocomial MRSA data presents special problems owing to constantly changing patient population and the fact that acquisition of MRSA is not usually marked by any clinical symptoms, and can only be imperfectly observed by microbiological screening. These two considerations mean that most standard methods cannot easily be applied. However, if certain assumptions (for example, about the timing of acquisitions) are made, then standard statistical procedures, such as survival analysis, may be applicable.

Recently, simulation-based Markov chain Monte Carlo methods have provided another approach to analysing such data that avoids the need for such arbitrary assumptions.^{68,69} However, such methods are not at present possible without a large amount of computer programming. The crucial point, however, is that whatever method is used, it should account for dependencies in the data. The most natural way to do this is to relate incidence to prevalence. Recent studies that consider 'colonisation pressure' as an explanatory variable in effect do just this.^{70,71} Most mechanistic models of infection assume that incidence is directly proportional to prevalence

(the mass action assumption), although other relationships are possible and should usually be considered.⁶⁷

The alternative approach is to model the correlations in the data without attaching any mechanistic meanings to the resulting models. Models of this class include time series methods such as autoregressive integrated moving average (ARIMA) models, which have recently been applied to nosocomial infections.⁷² These are recommended for the analysis of routine ITS data owing to the great flexibility they provide.⁵² Generally such methods require at least 20 phase I data points to enable the structure of the data to be assessed with any reliability.

External validity

External validity refers to the extent to which inferences about causal relationships can be validly generalised to different populations, settings and times.

Factors which may limit the degree to which results can be validly generalised include differences in patient mixes, hospital procedures, LOS and staffing levels. The greater the differences, the less confidence we can have that the interventions will have the same effect in different settings. In particular, generalising results between different types of wards may be particularly hazardous as very different processes may operate. For example, in neonatal units most infants acquire *Staphylococcus aureus* within a few days of birth and readmission is rare, whereas in geriatric wards a consideration of patients colonised on admission and frequent readmissions may be essential for an understanding of the transmission process.

Another major obstacle to generalisability is the fact that different strains may have different properties. What works for the control of one strain may not work (or work as well) for the control of another more transmissible strain.

Further problems arise owing to non-linearity and the existence of threshold effects. Thus, although patient isolation may be an effective way of reducing spread, the effect may vary in a non-linear way with the provision of isolation facilities (see Chapter 5). Generalising the results of a limited number of studies to different levels of provision of isolation facilities may therefore be problematic.

To a large extent, the degree to which results can be generalised depends on how well the outcomes are recorded. The more detailed the level of outcome recording, and the more the impact of an intervention can be understood mechanistically, the more confident we may be in generalising results to different settings. For example, if we can say that single-room isolation reduces transmission from a source by 20%, this result could be generalised to a more transmissible strain or used to consider increased provision of single rooms; the expected effects on MRSA outcomes could be investigated using a modelling approach. Conversely, the higher level conclusion that single room isolation leads to the control of MRSA could not be readily generalised to a more transmissible strain or different levels of room provision. If we knew even more about how the isolation worked (for example, what transmission routes were affected and by how much) our ability to generalise would increase still further. Therefore, outcomes that are open to interpretation at a lower, more mechanistic level should usually be preferred.

A special consideration when reviewing MRSA transmission studies is that generalisations need to be made at the population rather than the individual level. Studies that consider only selected subsets of patient populations may therefore be of limited value, unless such subsets are selected randomly from the entire population and are carefully defined.

Conclusions

This chapter has discussed what we consider to be the main threats to making valid inferences about the effect of interventions aimed at reducing the spread of MRSA.

Our treatment is by no means exhaustive, and important threats may have been neglected. For observational studies, assessments of the

plausibility of the many threats to validity are dependent on background knowledge of the area. At present there are large gaps in our understanding of the epidemiology of MRSA. Advances in this understanding may alter assessments of the relative magnitudes of the different threats, and as underlying mechanisms are understood better new threats to validity may emerge.

Many of the most plausible threats to valid causal inference, however, are unlikely to change. In particular, because of anticipated reporting biases, short outbreak reports must be considered to represent very weak forms of evidence, unless systematically reported. At best they may suggest interventions, document experience and difficulties encountered and show that what happened is at least possible. More formal studies were also shown to be highly vulnerable to large biases when interventions are made in response to unusually high MRSA levels. Such studies are at high risk of falsely attributing an effect to an ineffective intervention (or exaggerating the impact of an effective intervention). These problems were shown to be compounded by the fact that the most frequently used method for assessing the statistical significance of results of ITS data in MRSA studies was shown to be very likely to result in erroneous conclusions.

Without further research, the magnitude of other threats (such as those associated with confounding factors and seasonal effects) cannot be readily assessed. However, in the light of existing research we believe many of the threats may be very important. Taken together, the threats to valid causal inference described above were used as a checklist with which to assess the vulnerability of the studies included in this review, and also to establish how well authors managed to eliminate such threats by appropriate study design, reporting and analysis.

Chapter 3

Systematic review methods

There were six stages of article appraisal:

1. search of databases and handsearching
2. abstract appraisal
3. initial article appraisal
4. full article appraisal of high-priority papers: accept or reject for data extraction
5. data extraction: accept, reject or write to authors
6. write to authors: accept or reject.

Search strategy

We searched five major databases for studies relevant to the questions addressed by the review:

- MEDLINE (OVID Version 3.0 Release 7.8 Millennium), 1966–December 2000
- EMBASE (WinSpirs 4.01), 1980–December 2000
- CINAHL (WinSpirs 4.01), 1982–May 2000 (covers nursing and allied health publications)
- System for Information on Grey Literature in Europe (SIGLE) (WinSpirs 4.01), 1980–May 2000
- Cochrane, December 2000.

A search strategy was developed to find studies that covered the main subject areas addressed in the systematic review: MRSA screening, patient isolation and control. The search strategy was also designed to select studies which provided economic data or analysis related to MRSA. The broad aim of the strategy was therefore to select studies that included:

MRSA

AND

EITHER patient isolation *OR* epidemiological outcomes *OR* economic outcomes.

The search strategy was developed by the librarian (RL) working together with members of the review team (CCK, SPS). An initial strategy was developed for the MEDLINE database by translating terms representing broad subject areas into thesaurus terms or Medical Subject Headings (MeSH headings). Many of the thesaurus terms have associated narrower terms and initially these were

all included. Broader conceptual terms were also examined (by reading the scope notes provided by MEDLINE) for further possible relevant terms. For each thesaurus term, a list of equivalent text words was generated and these were linked to their respective thesaurus terms using the 'OR' logical operator. An initial search of the Cochrane Library Database did not reveal any relevant RCTs in this area, and for this reason a methodological filter for capturing RCTs has not been added to the original search strategy. Language limits were not imposed.

The initial search strategy was found to be overly inclusive, and captured >62,000 references. A large proportion of these represented *in vitro* studies and were not considered relevant to the review.

Subsequently modifications to the search strategy aimed at improving specificity included:

- Replacing the truncated text word 'isolat\$' with more precise phrases aimed at capturing the concept of patient isolation ('isolat\$' was found to result in too many references containing terms such as 'isolate' referring to laboratory studies of no relevance to the review).
- Dropping some of the less relevant narrower headings associated with the thesaurus term 'Communicable Disease Control'.
- Removing 'bacteraemia' as a text word, as this was considered to contribute to the large number of *in vitro* studies and to act as a redundant concept.

The final version of the MEDLINE search strategy was then translated for use in the EMBASE and the CINAHL databases. These strategies are presented in Appendix 1.

SIGLE was the fourth major database to be searched. This multidisciplinary scientific database does not support thesaurus searching, so a basic strategy using text words from the MEDLINE search strategy was compiled (see Appendix 1).

Finally, the Cochrane database was also searched using the text word 'MRSA' and the MeSH headings 'Methicillin-resistance' and 'Staphylococcus aureus'.

We also wrote to a number of authors requesting information on unpublished or recently published studies. However, owing to the very large volume of studies already included we later decided that we did not have the resources to include unpublished studies, or any studies appearing after 31 December 2000.

Handsearching

The trials list registers from the Cochrane Collaboration's Infectious Diseases Collaborative Reviews Group and the Wounds Collaborative Reviews Group were examined and none of the journal titles currently being handsearched by these two groups were considered to be relevant.

References in retrieved papers were searched for additional papers that appeared to be relevant to the review. Abstracts of such papers were appraised when available, and full texts of these papers retrieved and appraised otherwise. References in major reviews of the subject area were processed similarly.

Additional handsearching of two key journals was conducted to check the sensitivity of the automated search strategy. For this purpose, all abstracts from 1989 and 1999 from *The Journal of Hospital Infection* and *Infection Control and Hospital Epidemiology* were handsearched independently by two members of the review team (CCK and BDC). Where there was thought to be any ambiguity over whether papers would meet the inclusion criteria, the full texts of articles were retrieved and examined.

Abstract appraisal

Abstracts of all papers selected by the above search strategy were appraised together by two or three members of the review team (BSC, SPS, CCK). At no stage of the appraisal process were members of the review team permitted to appraise or review any paper on which they had been an author.

Papers were rejected on the basis of the abstract appraisal if they failed to meet one or more of the following three criteria:

- they described an MRSA outbreak or endemic MRSA
- the setting was a hospital
- an attempt to control MRSA was mentioned.

The last criterion was interpreted positively if isolation, screening, eradication therapy, feedback, hand-hygiene measures, antibiotic restriction or

ward closures were mentioned or if the terms 'containment' or 'control' (of outbreaks) were mentioned. This assessment was made using the title, abstract and keywords/MeSH headings.

Full copies of articles were obtained for all English language papers meeting these three criteria. When it was unclear whether one or more of these criteria were satisfied, full articles were also obtained provided that the other criteria were met.

Non-English language papers

The large volume of articles in languages other than English exceeded available translation resources and a slightly more stringent selection protocol had to be adopted. Non-English language papers were therefore accepted and full copies of the articles obtained if, in addition to the above criteria,

1. They were prospective studies or comparative studies where the comparison had not been suggested by any part of the data.

OR

2. They mentioned a specific screening policy.

OR

3. They mentioned a specific isolation policy.

This assessment was made by two reviewers (BSC, SPS or CCK) working with a translator when required.

We did not obtain articles in languages other than English when it was clear that the same study had also been reported in an accepted English language paper.

Editorials, letters and reviews

All editorials were excluded at the abstract appraisal stage.

Relevant reviews were identified during the initial abstract appraisal process. However, there was insufficient time to assess the full texts. Therefore, unless we had specific reasons to believe that they contained original data, these reviews were also excluded.

Letters to scientific journals were not automatically excluded, as it was known that some of these would contain original data.

Modelling and economic papers

Articles that did not necessarily meet the appraisal criteria but that contained economic data or data thought potentially valuable for estimating key epidemiological parameters for mathematical

models were also identified and obtained at the abstract appraisal stage.

After abstract appraisal, full papers were obtained for assessment by two members of the review team (BSC, SPS) in consultation with translators where necessary. When single articles contained more than one study, the component studies were processed individually as for full articles. In a number of cases a single study was described, or partly described, by more than one paper. In many of these cases no single paper provided all the relevant information. When this occurred, all relevant papers were dealt with together, and the article appraisal, data extraction and final accept/reject decision were based on information contained in all the relevant papers.

Initial article appraisal

The very large volume of papers accepted at this stage meant that we had to restrict our attention to a subgroup of the papers, as full data extraction for all papers would not have been feasible within the time constraints of the review. We chose to concentrate on studies employing higher quality designs and articles describing the highest levels of patient isolation as these interventions were considered to have the strongest face validity and would have the greatest implications for resource allocation and organisation of services. To select these 'higher priority' studies we had to introduce an initial article appraisal stage that had not initially been planned. To this end, the full articles were appraised by two reviewers and accepted into the next stage of the study only if they met at least one of the following three criteria:

- They described either a prospective study or a comparative study where the comparison being made had not been suggested by any part of the outcome data.
- An isolation or ward unit was used.
- Nurse cohorting (NC) was used.

Our definitions of prospective, isolation unit and nurse cohorting are those given in the Glossary. Those articles rejected at this stage are referred to in the Results section as 'low-priority' studies (see also Appendix 2).

Since formally implemented studies are the exception in this literature and almost non-existent for the higher levels of isolation, and we wanted to appraise as much of the evidence base as possible,

we did not restrict our attention to particular study designs. Even non-comparative studies with sufficient reporting detail and appropriate analysis could, in principle, enable some evaluation of the efficacy of interventions to be made.

Full article appraisal

Articles accepted by the initial article appraisal were then sent to two independent reviewers (BSC and one other from the team) with full written translations of non-English language papers when required. Reviewers were chosen in accordance with their areas of expertise provided that they had not contributed to the papers.

For each article, the reviewers were first required to answer the following questions:

1. Is this a report of an MRSA outbreak or endemic MRSA?
2. Is it a hospital setting?
3. Is an isolation strategy or policy mentioned?
4. Is there a relevant outcome in the form of MRSA transmission data for patients (including colonisation or infection with MRSA)?

If the answer to any of these questions was 'no', the paper was rejected. Otherwise, a full data extraction was performed.

Data extraction

Data extractions were performed independently by two data extractors (BSC and one of SPS, CCK, BSC, GFM, GJD and JAR), recording data on data collection forms designed for the purpose. An exception was made for the technical details of culturing and typing of the MRSA strains. These data were entered by one of the extractors (BSC) and then checked for accuracy by the second data extractor.

If no IW was mentioned, we assumed that no IW was used for MRSA patients. Otherwise, failure to mention a particular measure was not assumed to imply its absence. Definitions adopted for the purposes of data extraction are listed in the Glossary. Differences between extractors were resolved by discussion. Where consensus could not be achieved, a third member of the review team decided the matter.

Important aspects of the data extraction are outlined below.

Study designs

Studies did not always conform to standard experimental designs. As far as possible we followed the Cochrane Effective Practice and Organisation of Care (EPOC) group's guidelines for classifying study designs,⁷³ but in some cases we were forced to take a more descriptive approach.

Study populations

Details of all populations under investigation were recorded. Populations were considered to correspond to the level at which interventions were made and the outcomes presented. In most cases populations were wards or whole hospitals, although sometimes a unit consisting of several wards was investigated.

Study phases and interventions

Many studies were divided into two or more distinct phases characterised by changes in the MRSA control policy. For retrospective studies and informal outbreak reports we also divided the study period into distinct phases when possible, although such divisions were necessarily more subjective. We considered a change of phase to occur when there was a major change in the isolation policy or in another aspect of infection control practice or policy. Disagreements over the division of such studies into phases were resolved by discussion between extractors or recourse to a third party where necessary. Details of relatively minor within-phase interventions were recorded, but not used to define a phase. The start and stop dates of each phase were recorded.

Details of patient isolation, screening and other infection control measures including eradication of MRSA carriage, staff education, feedback of outcome measures and antibiotic policies and ward closures were recorded for each phase.

Outcome data

Primary outcome data representing total MRSA colonisation and infection, bacteraemias and pneumonias and deaths attributable to MRSA were recorded by extractors as described in the original papers, with precise details of the outcome, denominators and reported measures of uncertainty being recorded. Recorded outcomes included incidence, prevalence and numbers colonised on admission. Where such outcomes could be derived from data supplied in the papers, extractors were asked to make a note of this fact but not to carry out the calculations themselves, recording only the unprocessed data. Outcome data reported only graphically were

extracted either in parallel, using a ruler as necessary, or by a single reviewer using the data-extraction program DataThief II.⁷⁴

Secondary outcomes recorded included MRSA to MSSA ratios, staff carriage of MRSA and outcomes related to changes in infection control measures such as handwashing frequencies.

Economics

All quantitative economic data about the resources used in the interventions and their associated costs or the cost savings that resulted from the intervention were recorded. In addition, any comments on the wider economic implications of the interventions including any awareness of the opportunity costs involved were noted.

Bias and confounders

Reviewers attempted to identify potential confounders and sources of bias and any attempts to record, adjust for and prevent these. Bias was considered under four main headings: **selection bias** at entry (bias in the selection of the study populations and allocation to treatment group); **performance bias** (interventions apart from those under investigation); **detection bias** (unequal outcome assessment); and **attrition bias** (selection bias after admission of patients into the study).

Overall assessment

For each article we also recorded the authors' main conclusions regarding the role of isolation, screening, or other approaches for controlling the spread of MRSA. We also recorded our own preliminary assessment of these conclusions.

Author correspondence

Authors were contacted for additional information if:

1. Either the initial patient isolation policy or changes to this policy were not clearly defined as categorised in the full data extraction sheet.

OR

2. The screening policy or changes to this policy were not clearly defined in that it did not specify who, when and what body sites were screened.

These assessments were made by the two data extractors and any disagreements were resolved by discussion or recourse to a third party. Authors were given at least 1 month to respond.

Final inclusion/exclusion decisions

When requested additional information from authors had been obtained, or no response was received, final accept/reject decisions were made for all high-priority papers which had not already been rejected. These decisions were made by two reviewers (BSC and SPS or CCK) working in parallel.

Studies were rejected, on a consensus decision by two reviewers (or by a third party in the case of disagreement), when one or more of the following applied:

1. The timing of interventions was not clear. The precise meaning of 'not clear' depended on both the length of time series data and the intervals covered by data points. In particular, studies were rejected when it was not possible to tell whether outcomes occurred before or after interventions when this timing would have made an important difference to the interpretation of results.
2. The nature of the main isolation policy was unclear in that it could not be unambiguously

classified as none, barrier nursing, single rooms, cohorting, or isolation unit or was not otherwise specified.

3. When results were given only in terms of patient colonisation and not infection, and there was either insufficient information on the screening policy, or screening had changed sufficiently to make interpretation of colonisation data difficult. The definition of 'sufficiency' of information was again decided by consensus on a case-by-case basis.

All other studies were accepted when meaningful data could be obtained (i.e. the relevant MRSA-related outcomes were required to be available in a form that gave sufficient detail of outcomes and when they occurred).

Lack of information on the number of side rooms, number of beds in the isolation units, policy for isolating overflow patients who could not be accommodated by the main isolation policy and screening sites were not taken as reasons for rejecting studies.

Chapter 4

Results of systematic literature review

Search results (Figure 6)

Electronic database search

Abstracts selected by search strategy:

- | | |
|------------|------|
| • MEDLINE | 2585 |
| • EMBASE | 3165 |
| • Cochrane | 0 |
| • SIGLE | 11 |
| • CINAHL | 586. |

After removing duplicates, 4382 abstracts were selected by the electronic search.

Handsearching of selected years of *The Journal of Hospital Infection* and *Infection Control and Hospital Epidemiology* produced no additional papers. A small number of papers were also selected for full-article appraisal by searching reference lists in papers.

The abstract appraisal selected 254 papers, all of which were obtained.

Languages of selected papers

Of the accepted papers, 20 were in languages other than English. Twenty-nine other studies had been rejected at the abstract appraisal stage as not meeting the more stringent foreign language requirements. These 29 papers would have met the requirements for English language papers.

Of the 254 selected papers:

- 11 had been selected only for economic data or data relevant to modelling work
- 9 papers were considered not to describe individual studies, but rather to describe aspects of other included studies. These papers were subsequently grouped together and treated as single studies
- 132 papers were considered to be of low priority and 12 were rejected as they were found not to meet the initial abstract appraisal criteria
- 90 papers were considered to describe individual high-priority studies.

Full-article appraisals were made for the 90 high-priority studies together with an additional 14 papers that were initially classified as high-priority studies, but later reclassified either after the data extraction stage or following correspondence with the authors.

Twenty-seven of these 90 studies were rejected at this stage as they did not meet at least one of the four full-article appraisal criteria.

We wrote to the authors of 63 papers requesting further information. In five cases this was done following full-article appraisals because the studies were considered to be potentially valuable but from the reported data outcomes could not be related to interventions. Otherwise we wrote to authors following data extractions requesting additional information relating to the interventions.

We received replies from 37 of these requests and we made use of additional information supplied by authors for 23 of the studies finally accepted into the review. Another 23 papers were accepted without receiving any additional information from the authors.

The reasons for excluding studies are given in Appendix 2.

Data extracted from accepted studies (see Appendix 3)

The results of the data extractions for accepted papers are presented in tabular form (Appendix 3) as a detailed summary of extracted information, the authors' conclusions and their relevance to this review. The extracted information included details of the design, population characteristics, isolation, screening and eradication policies and other infection control interventions, in addition to the primary reported outcomes relevant to the review. The latter included the incidence of MRSA colonisation, MRSA infection, bacteraemias, pneumonias, colonisation upon admission and MRSA-attributable deaths. These are presented in

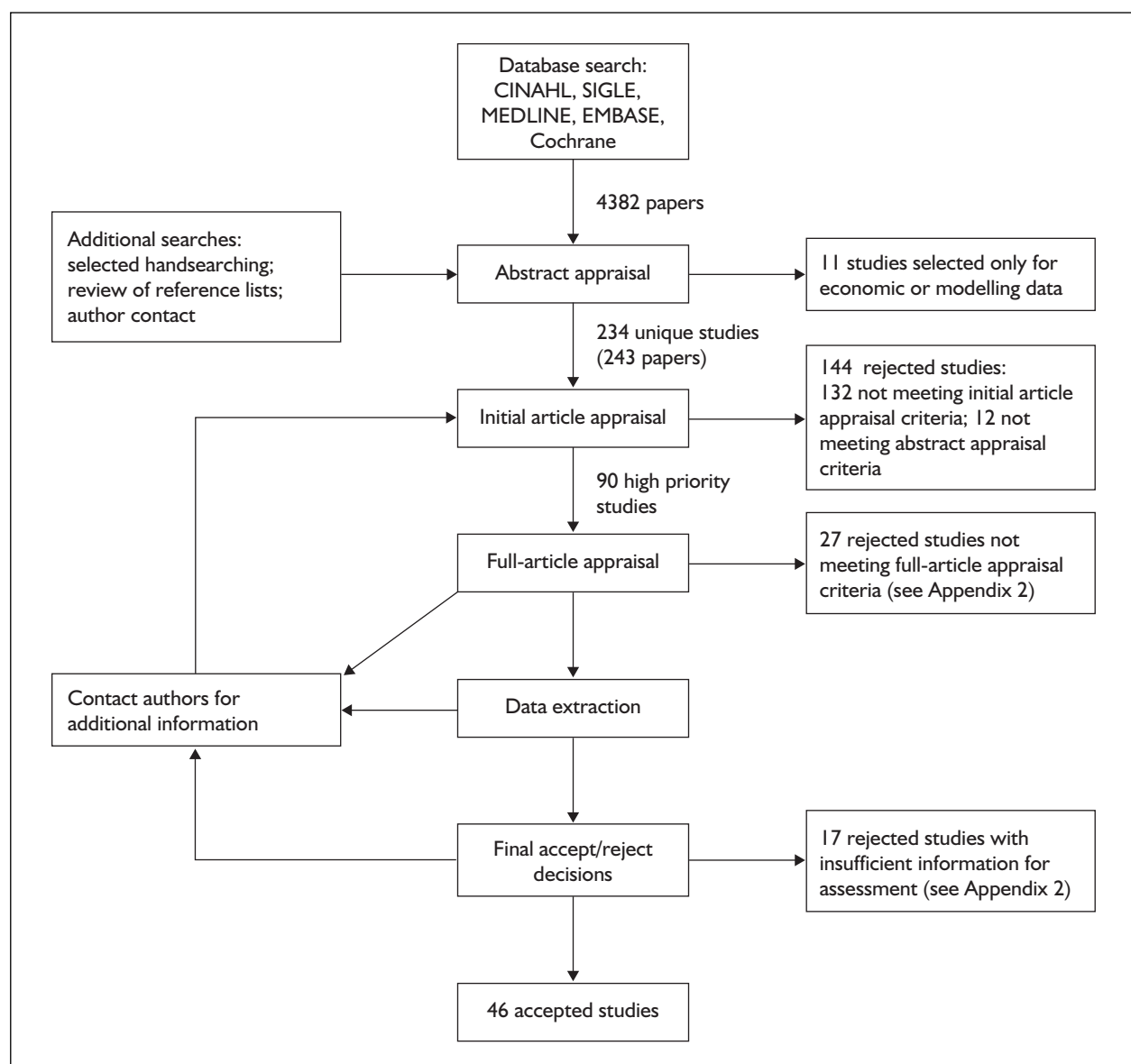

FIGURE 6 Flowchart showing inclusion/exclusion process of literature search

summaries as recorded for each of the phases in the papers. We also present, where these were provided, descriptive summaries of time series data, denominators, authors' definitions of primary data terms and measures of MRSA prevalence in the hospital, ward or unit. Secondary outcomes of possible relevance to the assessment of the control programmes are reported, including MRSA:MSSA ratios, healthcare worker (HCW) MRSA carriage and, when these were aspects targeted by the control programme, hand hygiene compliance and antibiotic usage. The tables also summarise MRSA strain details, economic evaluations, authors' statistical analysis and assessment of major threats to validity of inferences that could be made on the basis of that study.

General characteristics of accepted studies

Main isolation policies studied

The main isolation policy in 18 of the 46 accepted studies was an IW. Nine featured NC and featured other isolation policies (single-room isolation in seven, cohorting on bays in one, single rooms and cohorting in six, gowns and gloves only in three and no isolation at all in two).

Other interventions

In most studies, there was at least one other infection control measure operating along with the isolation policy. In all but five studies there was a screening programme. Handwashing education

featured in 14 and eradication in 18. Antibiotic restriction featured in four studies and feedback of infection rates or hand-hygiene in five. A combination of isolation, screening and handwashing education featured in 13 reports and these were combined with eradication therapy in eight studies.

Setting and population

In 23 studies the setting was an entire hospital, in one study it was three related hospitals and in another it was two related hospitals. One study used survey data from all Dutch hospitals. The remaining studies featured individual hospital units, including one burns unit, six medical, surgical or paediatric ITUs, four neonatal units or ITUs and a variety of other specialist medical or surgical units.

Study design

Study designs are summarised in *Tables 1–3*. There were no RCTs. There was one prospective cohort cross-over study, two prospective cohort studies with historical controls, nine prospective ITS studies (of which two had prospective data collection but unplanned interventions), six prospective observational one-phase studies, five hybrid retrospective/prospective ITS studies, one retrospective cohort study with systematic data collection and the comparison decided on in advance of examining the data, two other retrospective studies with the comparison decided on before examination of the data, 18 retrospective ITS and two retrospective observational studies.

Threats to internal validity

Below are presented the recording of potential confounders and sources of bias in the accepted studies.

Confounders

Antibiotic usage

There was no documentation of antibiotic use in 35 studies. Changes in antibiotic use were part of the intervention in five studies and so cannot be considered a confounder,^{56,75–78} although a detailed record of consumption was presented only in two.^{56,75} Details of antibiotic use were reported in four other studies^{55,79–81} and unquantified changes were alluded to in two studies.^{82,83} In one study⁸² we considered changes in antibiotic use to provide a plausible alternative explanation for the outcome of the study.

Staffing levels

Only five studies reported staffing levels or workloads.^{57,79,84,85,86,91} In those studies where ward closures formed part of the infection control measures, the resultant changes in staff–patient ratios could be considered part of the intervention.

Lengths of stay

In two studies,^{78,87} early discharge of MRSA patients was considered to be part of the intervention rather than a confounder, and this was considered to be true for those studies quoting implementation of the UK Guidelines.^{75,88–90} Four studies reported changes in LOS.^{56,91–93} More commonly reported was the number of admissions or discharges,^{57,76,77,81,92,93} changes in which can be assumed to be combinations of changes in bed occupancy, LOS and, in one study, bed numbers.⁹² It is not possible to differentiate between these, and changes in both occupancy and LOS could be operating even without a change in numbers of admissions or discharges. Only one study⁷⁹ reported variation in patient bed days. In five studies the data presented indicated that changes in LOS could provide plausible alternative explanations of outcomes of interventions.^{57,78,79,81,94}

Although only one study presented any analysis that fully adjusted for changes to LOS,⁹⁵ a number of studies presented outcome data in terms of events (infections/colonisations detected) per patient day or per 100 admissions,^{75,92,96} and this can be expected to provide a partial adjustment for changes in patient turnover. However, increasing patient turnover may be expected to reduce the opportunities for transmission from each infected patient admitted, but increase the number of patients admitted carrying MRSA. Analyses should adjust for both processes. Only one study followed up patients after discharge to look for infections.⁸⁸

Other potential confounders such as ward cleaning and patient–carer contact patterns were not recorded. Although these may provide less plausible explanations for changes in outcome data than other confounders, thorough studies of confounders might include them.

MRSA strains

Fourteen studies provided no typing details. Twelve provided DNA-based typing (of which four used only plasmid typing). The rest used only phenotypic methods (antibiograms or phage typing). In 20 studies there appeared to be one predominant strain. There was either no

predominant strain or this could not be assessed in the remainder.

In one study,⁹¹ a change in strain was considered to provide a plausible alternative explanation for the outcome. Gradual changes in resistance patterns were observed in another study,⁷⁶ but the major change in outcome took place before this, so it was not considered a plausible alternative explanation of the outcome.

Trends/maturation

Of 30 studies with two or more phases that presented preintervention time series, clear trends were apparent in 13. In all cases except two,^{57,89} the trend was for increasing MRSA levels in the preintervention phase. In the remaining 17 studies either the time series was too short to assess trends, or stable incidence was observed. Eight studies with two or more phases presented collapsed data, with time series from each phase summarised in a single point.

This loss of information renders these studies highly vulnerable to trends, although the apparent predominance of increasing trends suggests that this is more likely to mask true effects of the interventions than to result in the spurious attribution of non-existent effects. However, in one study,⁵⁷ the trend towards reduction of MRSA in the pre-intervention phase provided a plausible alternative explanation of the outcome.

An important cause of trends may be changing numbers of patients colonised on admission. Of the 35 studies with time series data (two or more data points per phase) only 18 made an assessment as to whether or not cases were colonised on admission. In most of these either the time series was too short to assess trends, or no time series for numbers colonised on admission was given, or reports were of short outbreaks where all cases except the index case could reasonably be assumed to be hospital-acquired.

Five studies presented sufficient data to assess trends in numbers colonised on admission.^{83,91,94,97,98} Farrington and colleagues⁹¹ showed that numbers colonised on admission, although stable over several years, subsequently increased rapidly, accounting for a large proportion of MRSA cases and appeared to be an important cause for the increase in hospital-acquired cases (the ratio of new nosocomial cases to those colonised on admission changed little during the study). Girou and colleagues⁹⁴ and Kac and colleagues⁹⁷ found that numbers colonised on

admission remained stable and low during 4 and 3 years, respectively. Murray-Leisure and colleagues⁸³ showed that numbers colonised on admission, which were recorded only in the intervention phase, fell over the period measured. Pearman and colleagues⁹⁸ reported that numbers colonised on admission increased with time. In two studies,^{89,91} changes in numbers colonised on admission were considered to provide plausible alternative explanations of outcomes.

Seasonal effects

Of 14 studies with time series data (weekly, monthly, quarterly) of ≥ 18 months, inspection suggests that seasonal effects may have been operating in two^{75,77} confirming that these constitute a potential confounder. In studies with shorter time series it was not possible to disentangle seasonal from treatment effects. In four studies,^{28,75,99-101} seasonal effects were considered to provide plausible alternative explanations of outcome. In two^{97,102} they were considered to be potential, but less plausible, alternative explanations for the outcomes.

Detection bias

Change in screening practice

This constitutes a potential source of detection bias in studies where the outcome is colonisation, not infection, or where the two are summated as the only outcome measure. This might result in an initial 'rise' in MRSA as screening intensifies, and a 'reduction' when it relaxes. Fifteen studies presented outcomes in this way, or reported insufficient infection data to allow assessment of the interventions, but in three of these there was no change in screening policy.¹⁰³⁻¹⁰⁵ Two^{98,106} had systematic screening programmes so changes in detection effort do not provide plausible threats to the conclusions. In one nurse cohorting (NC) study,⁹⁴ the intervention was an increase in admission screening, which does not plausibly explain the slight reduction in MRSA acquisitions. Barakate and colleagues¹⁰⁷ and Hartstein and colleagues¹⁰⁸ both had no screening, so screening effort changes are again not threats. Arnou and colleagues,⁷⁹ Murray-Leisure and colleagues⁸³ and Pearman and colleagues⁹⁸ reported increased screening effort, which cannot explain the reduction in MRSA numbers observed. The remaining four studies^{28,75,100,109} reported constant although unsystematic screening policies (without information on number of patient screens), so again screening seems not to represent a major plausible threat.

Overall, changes to screening practice do not appear to provide plausible alternative explanations

of outcomes for studies which did not separately record infection data. They might, however, result in the effect of interventions being underestimated, rather than the opposite, owing to the tendency for screening effort to increase during studies.

Change in laboratory methods

Two studies reported changes in the laboratory methods, such as antibiotics used in agar for culture.^{82,94} The effect of this is not clear. Sixteen studies gave no details of the culturing media used.

Outcome assessment

Unconscious selection that may result if staff involved in collecting outcome data are aware that a study is under way represents a potential bias that is difficult to quantify. Only three studies^{57,78,93} reported any blinding of those involved in outcome assessments. In all cases it was partial, providing limited protection against such bias. For retrospective studies such unconscious bias should not be important, although there may still be temporal changes in, for example, laboratory technique, which could systematically distort the results.

Where the outcome is infection, the absence of formal criteria represents a potential source of bias that is hard to quantify. Twelve of the 35 studies reporting infection outcomes used no such criteria.

Attrition bias

Reducing LOS was considered a form of attrition bias (see above).

Regression to the mean and reporting bias

Only 12 of 38 comparative studies indicated that comparisons being made were decided on independently of the data. In 11, regression to the mean effects was considered to be a possible^{84,94,95,110} or likely alternative explanation of outcomes^{75,77,79,81,85,89,100} because interventions were made in response to higher than usual MRSA levels in settings with endemic MRSA. Reporting bias was hard to assess, as one does not know which studies were not reported. Certain types of report can be expected to be highly vulnerable to reporting bias. In particular, short retrospective studies where the comparisons are suggested by observed outcomes are highly vulnerable to bias (see Chapter 2). Selective reporting of outcomes can be expected when the data themselves influenced the decision to report them. We considered 11 studies to have designs that are particularly vulnerable to reporting bias.^{28,85,87,98–100,103,105,111–113}

Selection bias

Only five studies attempted to record possible differences in patient populations between phases. Cosseron-Zerbib and colleagues⁸⁴ reported a large increase in the percentage of liver transplant patients, although this might be expected to lead to more MRSA cases, rather than to the observed reduction. Girou and colleagues⁹³ reported comparable numbers of patients considered to be at risk of acquiring MRSA in each phase, Kac and colleagues⁹⁷ reported similar risk factor profiles in wound care centre patients, and Souweine and colleagues⁷⁸ reported similar severity of illness scores and ventilation rates for ITU patients. Yano and colleagues¹¹⁴ reported different preoperative complication rates in surgical patients between phases, but this was not considered to explain outcome. In two studies, changes in patient mix were considered to provide plausible explanations for changes in outcomes. In one, burns patients were removed from general wards to a self-contained unit, but not as part of the intervention,⁹⁶ and in the other a decline in admission of chronic care patients, who might be more likely to carry MRSA, was reported.⁸³ Selection bias was considered to provide a plausible alternative explanation for outcome in one study not based on time series data, where those hospitals that isolated patients immediately might be better at other aspects of infection control.¹⁰⁹ This might distort the degree to which prevention of spread can be attributed to isolation *per se*. No study attempted to adjust for such differences in patient populations in the statistical analysis of cross-infection data.

Threats to construct validity

In only one study with prospective data collection was any blinding of carers to the study explicitly described.⁵⁷

Threats to statistical conclusion validity

Of 24 time series studies in which statistical analysis was carried out, it was clearly inappropriate in all but one case.⁹⁵ Analysis was appropriate in one non-time series study by Esveld and colleagues.¹⁰⁹

In conclusion, recording of potential confounding factors in the studies in the review was very poor and many studies were vulnerable to bias. In almost all cases it was not possible to rule out a

number of potential alternative explanations for changes in outcome attributed to particular interventions. There were no reports that made any attempt to adjust for potential confounders in the analysis of time series data, although one study¹⁰⁹ carried out some adjustment for strain differences as a confounder. In many studies confounding factors or likely biases provided plausible alternative explanations of outcome.

Assessment of evidence for control of MRSA by interventions in accepted studies (Tables 1–3)

A condensed tabulated summary of the extracted data, including the most important confounders and biases, is presented in *Tables 1–3*. These describe the setting, population, design, main interventions, changes and outcomes with the reviewers' qualitative assessment of the evidence. These provide assessments of the efficacy of those interventions relevant to this review, taking into account the most important potential confounders and biases, including the most plausible alternative explanations. Studies were categorised into three classes in these tables according to the intensity of isolation used for various MRSA-positive patients as follows: (1) IW (or isolation unit) (*Table 1*); (2) designated nursing staff on wards other than IWs (i.e. NC) (*Table 2*); (3) other (e.g. single-room isolation, patient cohorting, gowns and gloves, none) (*Table 3*). Formal meta-analysis was inappropriate owing to the very large diversity of settings, interventions and outcome measures. The strength of evidence in each study was therefore evaluated independently by two reviewers by examining the study design, quality of data and presence of plausible alternative explanations of outcomes and characterised on a case by case basis as 'none', 'weak', 'evidence' or 'stronger' evidence.

Isolation ward studies (Table 1)

Design

All but one of the 18 IW reports were retrospective studies, 16 were ITS and two^{99,111} observational one-phase reports. Most ITS were two phases (seven studies) with one comprising six phases,⁸⁹ another comprising four phases⁹⁶ and six comprising three phases.^{75,77,88,98,103,115} There was one three-phase ITS with formal systematic prospective data collection but with unplanned interventions which did not represent a formal study.⁸⁵

Setting and population

For all but three studies,^{77,85,88} the population under investigation was in a single hospital. Brady and colleagues' report⁷⁷ examined the effect of a change in screening on MRSA levels in a cardiothoracic surgical unit with an IW elsewhere in the hospital. Campbell and colleagues' report⁸⁵ was set in a neonatal intensive care unit (ICU) and that of Cox and colleagues⁸⁸ concerned three related hospitals.

Endemicity and epidemicity

Fifteen studies described situations where MRSA was not considered to be endemic initially. In seven^{76,82,88,89,91,96,115} MRSA became endemic, whereas it was considered to remain epidemic in eight.^{28,83,87,95,98–100,103,111} In three others^{75,77,85} MRSA was considered to be endemic throughout.

Size of studies

Eight studies were small, with <50 MRSA cases of infection or colonisation;^{28,85,87,98–100,103,111} two had between 50 and 96 such cases^{77,115} and seven^{75,82,83,88,89,91,96} had between 150 and 1000 such cases (actual ranges: 152–965). In addition, there was a study with 5343 cases.⁷⁶

Length of studies

Six studies were short in duration (3–8 months;^{28,85,87,99,100,111} five were intermediate (18–30 months);^{75,88,98,103,115} and seven long-term, four of 3.5–5.5 years^{77,83,89,96} and three of 11–15 years.^{76,82,91}

Comparators

Twelve reports compared phases with and without IW (with or without other interventions); four had an IW throughout but the comparator was a change in other policies such as screening^{76,77,85,91} and two had no comparator, being one phase reports with the IW operating throughout.^{99,111} For the studies where comparisons between phases were made, all comparisons were unplanned.

Results of comparator studies where the comparator was an IW

These studies fell into two groups: small, successfully controlled outbreak reports, and large reports of IWs in the management of MRSA that had become endemic.

Small outbreak reports^{28,87,98–100,103,111}

These studies were reports of small, short (3–8 months) and successfully controlled outbreaks where the evidence was consistent with control of MRSA by the isolation ward and other measures. However, all were subject to major difficulties in

TABLE 1 IW studies

Study	Setting and study population	Design	Main interventions	Patient outcomes	Assessment of evidence
Alvarez <i>et al.</i> , 1985 ⁹⁹	Teaching hospital (570 beds)	Retrospective (uninterrupted) time series. 1 phase: 8 months	IW, screening, handwashing education. No major changes during study	11 patients with MRSA; all but one in same 3-month cluster. 2-month follow-up with no further cases	Weak evidence consistent with control by interventions. Large reporting bias likely with this type of study
Brady <i>et al.</i> , 1990 ⁷⁷	Cardiothoracic surgical unit (37 beds)	Retrospective ITS. 3 phases: 37, 5 and 24 months	IW in all phases. Screening and triclosan body washes introduced (phase 2) then antibiotic restriction (phase 3)	Total of 64 MRSA infections. Infections increased gradually (phase 1) then fell (phases 2 and 3)	No evidence available for assessing effect of isolation ward. Weak evidence consistent with reduction of infections on unit by other measures, but regression to mean likely
Campbell <i>et al.</i> , 1998 ⁸⁵	Neonatal ICU (48 beds)	Prospective ITS. 3 phases: ~2, ~1 and ~4 months. Phases and end-point not predefined	IW in all phases. Screening changed from weekly (phase 1) to twice weekly. Phase 2: handwashing education, feedback, and extra sinks. Phase 3: additional HCW education on i.v. insertion and maintenance	5 infections (all bacteraemias). 10 colonisations. 1–2 bacteraemias in each 4-week period in phases 1 and 2. None (and no other MRSA infections) in phase 3. Fadeout occurred 2.5 months into phase 3	Weak evidence consistent with eventual control by combined measures in phase 3. Stochastic effects are likely to be dominant and large reporting bias likely with this type of study
Cox <i>et al.</i> , 1995 ⁸⁸	One general hospital (hospital A) and two long-stay/rehabilitation hospitals (B, C). (750 beds in total)	Retrospective ITS. 3 phases (at hospital A): 5, 4 and 11 months	Phase 1: single rooms and cohorting. Phases 2 and 3: IW. Eradication and extensive screening throughout, including preadmission from phase 2	83 MRSA-infected patients, 334 colonisations. Hospital A: 1–4 infections/month in all phases. Last month of data collection showed very low colonisation incidence. Hospital B: continuous detection of MRSA cases with no clear trend. Hospital C: apparent elimination of MRSA 14 months after isolation ward opened	Evidence that combined measures in all phases failed to prevent sustained spread at general hospital A. No evidence of control at long-stay rehabilitation hospital B. Weak evidence of control at long-stay rehabilitation hospital C. Interpretation of hospital B and C data difficult without colonisation on admission data due to inter-hospital transfers
Duckworth <i>et al.</i> , 1988 ⁸⁹	Teaching hospital (645 beds)	Retrospective ITS. 6 phases: 4, 3, 13.5, 4, 1.5 and 26 months	Initial isolation mainly single rooms + some cohorting (phases 1–3), changing to mainly IW (phases 4–6). Simultaneous changes to screening, eradication and other measures	~408 MRSA infections. Incidence of MRSA infection increased in phase 3, was sustained at a higher level, then fell in phase 4 from 3–4 per week and remained at a reduced level (1–2 per week)	Stronger evidence supporting efficacy of combined measures in reducing incidence, but many potential confounders not recorded

continued

TABLE 1 IW studies (cont'd)

Study	Setting and study population	Design	Main interventions	Patient outcomes	Assessment of evidence
El Hagrasy <i>et al.</i> , 1997 ⁸⁷	General hospital (550 beds)	Retrospective ITS. 2 phases: 1.5 and 4.5 months	Phase 1: cohorting on closed bays Phase 2: IW and additional IW measures including early discharge of MRSA patients. Eradication, hand-hygiene education and screening throughout	45 MRSA cases, 19 infections. Monthly incidence of new MRSA cases increased each month in phase 1 and decreased each month in phase 2 (max. 13, min. 2)	Weak evidence consistent with control by combined measures in phase 2. Stochastic effects may be dominant. Large reporting bias likely with this type of study
Farrington <i>et al.</i> , 1998 ⁹¹	Teaching hospital (1000 beds)	Retrospective ITS. 2 phases: 9.5 and 2.5 years	Continuous operation of IW. Screening, ward closure and eradication policies relaxed slightly in phase 2	221 MRSA acquisitions, 206 colonised on admission, 61 uncertain. Number colonised on admission and acquisitions stable and low for 9.5 years. Major increase in both 1 year prior to control policy changes. Increases continued after the changes	Stronger evidence supporting control of MRSA for 9.5 years by combined measures followed by eventual control failure related to rise in numbers colonised on admission or to change in strain rather than changed control measures
Faoagali <i>et al.</i> , 1992 ⁷⁶	Teaching hospital (1200 beds) initially free of MRSA	Retrospective ITS. 2 phases: 7 and 8 years	IW throughout. Additional measures in phase 2 include: segregated areas for highly susceptible MRSA-free patients with prescreening of admissions and transfers in; handwashing education; antibiotic restriction	Total MRSA increased rapidly in phase 1 and during the first 2 years of phase 2. Numbers were slightly lower during the next 3 years, but subsequently increased and appeared to stabilise at a high endemic level	Stronger evidence that combined control measures in both phases failed to prevent MRSA spreading and becoming endemic
Jones and Martin, 1987 ¹⁰³	Tertiary hospital (~750 beds)	Retrospective ITS. 3 phases: ~10, 5 and 6 months	Phases 1 and 3: single-room isolation and cohorting. Phase 2: IW, handwashing education. Eradication and contact screening all phases	29 MRSA cases. Incidence increased near end of phase 1 and fell in phase 2. Fadeout occurred near start phase 3	Weak evidence consistent with control by combined measures. Large reporting bias likely with this type of study
Law <i>et al.</i> , 1988 ¹¹⁵	General hospital (~400 beds)	Retrospective ITS. 3 phases: 12, 3 and 15 months	Phase 1: no intervention. Phase 2: IW, ward closures, 3 cohorts (clean, exposed and MRSA), eradication therapy. Move to new hospital with better IC facilities. Phase 3: isolation measures only in minor outbreaks	77 MRSA cases (40 infections). Infections increased in phase 1, fell sharply in phase 2 and stayed low	Weak evidence consistent with control by IW, ward closures and cohorts. Move to new hospital is a major confounder

continued

TABLE 1 *IW studies (cont'd)*

Study	Setting and study population	Design	Main interventions	Patient outcomes	Assessment of evidence
Linnemann <i>et al.</i> , 1982 ⁹⁶	University hospital (600 beds)	Retrospective ITS. 4 phases: 15, 6, 6 and 23 months	Phase 1: single rooms and cohorting. Phase 2: IW. Phase 3: single rooms and cohorting Phase 4: as phase 1. Trauma service disbanded and burn service relocated to new unit. Screening and eradication for only HCWs throughout	317 MRSA-infected patients. Infection incidence rose before IW opened then fell slightly. MRSA persisted for the rest of the study, with no evidence of an increasing trend. Incidence eventually fell to very low levels in phase 4. MRSA bacteraemias rose first 3 years and halved in the 4th year	Weak evidence that isolation ward reduced MRSA transmission. Relocation of major MRSA reservoir (burns unit) and reduction in number of beds/room provide plausible alternative explanations
Murray-Leisure <i>et al.</i> , 1990 ⁸³	General hospital (855 beds)	Retrospective ITS. 2 phases: 32 and 12 months	Phase 1: single-room isolation Phase 2: IW with changes to screening	177 new MRSA cases. MRSA cases increased throughout phase 1 then fell to low levels in phase 2	Evidence consistent with control by isolation ward and screening, but change in numbers colonised on admission provides a plausible alternative explanation
Pearman <i>et al.</i> , 1985 ⁹⁸	Teaching hospital (955 beds)	Retrospective ITS. 3 phases: 5, 1 and 24 months	Phase 1: single-room isolation and screening Phase 2: single-room isolation and screening extended to patients from outside Western Australia Phase 3: IW and increased screening	35 MRSA colonisations, 24 infections. One large cluster of cases from last month of phase 1 to first month of phase 3 (19 cases); then sporadic cases (≤ 2 /month). Outbreak ended within 4 weeks of IW opening, and long-term control was achieved	Weak evidence consistent with control by IW and extended screening. Reporting biases likely with this type of study
Selkon <i>et al.</i> , 1980 ⁸²	Teaching hospital (1000 beds)	Retrospective ITS. 2 phases of 5.5 years each	Isolation changed from single rooms (phase 1) to IW (phase 2)	965 MRSA infections. MRSA infections increased prior to the opening of IW, and subsequently decreased	Evidence consistent with control by IW, but changing antibiotic use provides a plausible alternative explanation
Shanson <i>et al.</i> , 1976 ²⁸	Teaching hospital (~350 beds)	Outbreak report. Retrospective ITS. 2 phases: ~3 and ~1.5 months	Phase 1: single-room isolation and patient transfer to another hospital. Phase 2: IW then NC for remaining patients when IW closed	Total cases: 16; 14 in phase 1, 2 in phase 2	Weak evidence consistent with control by IW, but large reporting bias likely with this type of study
Shanson <i>et al.</i> , 1985 ¹¹¹	University hospital (450 beds)	Retrospective (uninterrupted) time series. 1 phase of 4 months	Control measures included IW, screening, handwashing education and ward closures. Many minor changes during study	15 MRSA cases. Outbreak terminated after 15 MRSA colonised or infected patients, and ~2.5 months after detection of first case	Weak evidence consistent with control by combined measures. Large reporting bias likely with this type of study

continued

TABLE 1 IW studies (cont'd)

Study	Setting and study population	Design	Main interventions	Patient outcomes	Assessment of evidence
Stone <i>et al.</i> , 1998 ⁷⁵	Acute elderly care unit (66 beds) and general medical unit (101 beds) in a teaching hospital	Retrospective ITS with non-equivalent control group. 3 phases: 5, 4 and 9 months	Patient isolation with single rooms and cohorting in phases 1 and 3, both units. IW used in phase 2 for all patients over 65 years old (both units). Additional control measures in acute elderly, phase 3: antibiotic policy; handwashing education and feedback	Total cases: 52 (acute elderly); 102 (general medical). MRSA incidence increased in second half of phase 1 in both units, and fell back to initial levels in phase 3. In acute elderly, incidence in last 3 months of phase 3 was ~6 times lower than equivalent phase 1 period	Not possible to assess effect of IW from data presented. Weak evidence for efficacy of antibiotic policy, feedback and hand-hygiene on elderly unit in phase 3, but numbers are small. Regression to mean likely and seasonal effects possible
Ward <i>et al.</i> , 1981 ¹⁰⁰	General hospital (463 beds)	Retrospective ITS, outbreak report. 2 phases: ~1.5 months each	Phase 1: single-room isolation, contact screening. Phase 2: IW, followed by eradication policy	19 MRSA cases. 1–4 cases in each week of outbreak. Ended only after eradication therapy	Weak evidence consistent with control by combined measures. Stochastic effects likely to be dominant, and large reporting bias likely with this type of study

interpretation. First, when numbers are small, even where there is the potential for a major outbreak owing to inadequacy of control measures, stochastic effects could dominate and termination (fade-out) of the outbreak can be expected to occur with non-negligible probability. Second, as all comparisons were unplanned, major reporting biases can be expected as reports of successful control may be more likely to be written up and published than unsuccessful interventions. There was little chance of knowing how many similar unpublished attempts had failed. Both processes would give an exaggerated estimate of the effect of interventions.

Seasonal factors also constitute a potential confounder and provide plausible alternative explanations in the shorter studies, especially as MRSA is likely to be more frequent in the winter months.^{28,99}

Consequently, although the results from these studies were all consistent with control of (non-endemic) MRSA, they could also be consistent with other interpretations. In particular, it was impossible to rule out the possibility that interventions would not be able to control MRSA if introduced repeatedly.

Other difficulties also existed. In Pearman and colleagues' report,⁹⁸ the rise in total MRSA might have been explained by increases in screening. No separate infection outcome was reported, which was unlikely to be affected by changes in screening intensity. There was also a difficulty generalising these results to other settings. It was undoubtedly apparent that control coincided with the use of an IW in these studies, and one might conclude that the best hope of controlling or eradicating MRSA would be the opening of an IW as soon as MRSA first appeared in a hospital. Models presented in Chapter 5 provide theoretical reasons for why this might be problematic in settings with endemic MRSA.

Large reports of IWs in the management of MRSA that had become endemic

Duckworth and colleagues' 4.5-year report⁸⁹ presented evidence supporting control of MRSA by an IW, combined with screening and eradication therapy. The main outcome was weekly infections, which avoided the problem that would have been posed by a colonisation outcome in view of the substantial changes to screening. The reduction in infection incidence was large, there was no strain change and factors such as seasonality and prior trends appeared to be

unimportant. However, information on other potential confounders such as antibiotic use and LOS are not recorded, so other interpretations of the observed decline in MRSA infection cannot be ruled out. As in many studies, full interpretation of the data requires prevalence and colonisation on admission data, which, as in most studies, were missing from this report. It was not possible to assess the relative contribution of the different elements of the control policy to the fall in MRSA, and this was true of nearly all studies.

The 21-month report by Cox and colleagues⁸⁸ of an outbreak at three inter-related hospitals (one district general and two rehabilitation and long-stay hospitals) claimed to demonstrate containment by an IW with eradication and screening. Outcomes were given as numbers of monthly cases of MRSA colonisation and infection, although interpretation of the former was difficult because of a very large increase in screening. The evidence, particularly that based on incidence of infection, was consistent with control at the two rehabilitation and long-stay hospitals. However, in the main hospital site, where most cases were detected, there was no downward trend in infection following the intervention, and the reduction in colonisations was restricted to a sudden drop in one month several months after the isolation ward opened. This occurred at the end of the study, after which the isolation ward was shut and no further data were presented. The evidence, at least at the main general hospital site with most of the 400 cases, did not support control of MRSA by these interventions. There was no strain change, and seasonality and prior trend appeared to be unimportant. There was no information, however, on other potentially important confounders such as antibiotic use and LOS and no data on prevalence or colonisation on admission. Interpretation of the data at the other two hospitals was compromised by lack of prevalence and, in particular, colonised-on-admission data, as many of the patients were transferred from the main general hospital. It may indeed be that the interventions at these sites were successful at preventing the spread of MRSA if cases were all positive on admission after transfer from the general hospital.

Selkon and colleagues' 11-year study⁸² reported the eventual control of MRSA following the opening of an IW half-way through the period and provided evidence supporting control by this measure. An alternative plausible explanation acknowledged by the authors was the unquantified reduction in tetracycline usage. However, this

began some time before the IW opened. Other hospitals at the time reported similar declines in MRSA without the use of an IW, suggesting that factors other than an IW, such as antibiotic use, may have been responsible.¹¹⁶

Murray-Leisure and colleagues' report⁸³ of nearly 4 years presented monthly evidence supporting control of MRSA by an IW combined with more intensive screening. This was reflected most strongly in the disappearance from the hospital of MRSA bacteraemia. In fact, there were no cases after the IW opened, the previous incidence having been approximately one case per month. A plausible alternative explanation, coincident with the opening of the IW and again acknowledged by the authors, was the fall in numbers of patients colonised upon admission. Transfers into the institution from other healthcare facilities fell at the same time.

The authors hypothesise that the decline in those colonised on admission may have been due either to greater vigilance on the part of those referring institutions or to a generalised decline in MRSA reported at other institutions.¹¹⁷ This implied that their own hospital's MRSA levels might simply have reflected local trends. Another confounder might have been the reduction in cephalosporin usage, which, although unquantified, was described by the authors as 'heavy' until 3 months after the IW opened. MRSA was already declining by then, but it was possible that, if use had fallen significantly, it might have contributed to the lower MRSA levels.

In the two studies by Law and colleagues¹¹⁵ and Linnemann and colleagues⁹⁶ factors peculiar to the particular setting may have had the greatest influence on control or containment of MRSA, and therefore made it hard to generalise results from these studies to other settings. In Law and colleagues' study,¹¹⁵ the major confounder was a move from an old 'workhouse' hospital with an MRSA epidemic to a new, cleaner hospital with better infection control (IC) facilities. In Linnemann and colleagues' report,⁹⁶ the removal of the main MRSA reservoir, the burns unit, from the general wards to its own self-contained unit, was a plausible explanation of the fall in MRSA. Renovation of the hospital, replacing five-bedded with two-bedded rooms took place throughout the study and, like the closure of the burns unit, was not planned as an IC measure. This may also have contributed to the fall, and to the maintenance, of lower levels once the burns unit had relocated.

Comparator studies where the change was not introduction of an IW

In Faoagali and colleagues' 15-year study⁷⁶ of an epidemic MRSA outbreak that became endemic despite early use of a large IW, the comparator was other infection control changes such as hand-hygiene (unrecorded), antibiotic restriction (unquantified) and increased preadmission or transfer screening of patients admitted to selected units.

There was very strong evidence, especially from the bacteraemia data, that control was not achieved and that the control measures failed to prevent large increases in MRSA. The resistance pattern of the MRSA changed slightly, although only 2 years of data are presented 8 years apart, but this does not seem adequate explanation of the failure of control, which preceded changes in MRSA resistance patterns. No other typing data are available. There was a big increase in admissions in the last year of the report, suggesting either reduced LOS or increased bed occupancy, both of which might have affected MRSA levels. However, this did not provide a plausible alternative explanation, in that high levels had long since been established. It was possible that the increase in screening contributed to the rise in total MRSA, but it would not have contributed to the parallel rise in MRSA bacteraemia. However, it was not possible to interpret the data fully without information on prevalence and the numbers colonised on admission, or to determine if control measures were effective at reducing the rate of rise, or how high endemic levels might have reached without them.

An IW was in operation throughout Farrington and colleagues' 12-year study.⁹¹ The changes in policy were less stringent screening, eradication and ward closure. Repeated introductions of MRSA were controlled for almost 10 years, during which time MRSA levels were stable and low. The subsequent rapid rise in MRSA levels, which the authors attribute to the change in control policy, seem to be more plausibly explained by a rise in the number of colonised patients upon admission, which predated the change in policy by 1 year. At the same time as the MRSA incidence started to rise, there was a change in strain type, providing another plausible explanation for control failure. This paper not only has a long time series and gives clear details of IC policies, and their changes, it formally records more potential confounders than any other paper and was therefore of particular value. LOS fell as MRSA case numbers rose, but this might be expected to improve MRSA

outcomes, rather than the reverse (owing to the reduced chance of detecting infections during patient stays). Nurse workloads rose slightly, but this did not seem to provide a plausible explanation for the very large rise in MRSA cases. Reduction in the proportion of trained nurses on the wards also rose, but seem unlikely to have contributed to MRSA levels as much as the change in strain or rise in numbers colonised on admission. Although this paper did not provide definitive proof of the effect of an IW, it allowed us to consider a number of alternative explanations by recording many potential confounders and presenting a long enough time series with sufficient data points, to allow trends to be spotted early.

Brady and colleagues' study⁷⁷ was set in a cardiothoracic surgery unit in a hospital with a separate IW. The main change on the unit was in the screening and antibiotic policies, and the introduction of triclosan body washes. The evidence was consistent with the effectiveness of the changes in reducing MRSA in the unit but regression to the mean was a plausible alternative explanation. One cannot, however, extract any data regarding the effect of the IW on MRSA levels in the hospital or unit.

In Campbell and colleagues' short outbreak report,⁸⁵ an IW operated throughout and the changes were in screening and HCW education. The evidence was consistent with control of the outbreak but, as in most small successful outbreak reports, regression to mean and the inherent reporting bias were threats to the validity of this conclusion.

Although Stone and colleagues' report⁷⁵ covers the period when an IW became operational, little evidence regarding its effectiveness was presented. The emphasis was on the post-IW period in which the effect of an enhanced IC policy (antibiotic restriction, feedback of MRSA rates and hand-hygiene education) was assessed by comparing MRSA levels in acute care of the elderly wards where the policy was introduced with those in general medical wards where the policy was not in operation. The evidence was consistent with control, but regression to the mean was a plausible alternative explanation.

Two non-comparator IW studies^{99,111} were both short outbreak reports and are discussed above.

Conclusions: IW studies

Although it was possible that early implementation of IWs, as in the successful small outbreak reports,^{28,87,98–100,103,111} may control MRSA,

inherent reporting bias, regression to the mean and stochastic or seasonal factors made it impossible to rule out other explanations. These studies were therefore considered to present only weak evidence of control of MRSA by an IW. It was hard to generalise from studies^{96,115} where other factors specific to those settings were in operation or to conclude from those IW studies where the comparator was not an IW, what the effect of an IW might be.^{75,77}

Two studies, by Selkon and colleagues⁸² and Murray-Leisure and colleagues,⁸³ were considered to present evidence supporting a large reduction in MRSA by introduction of an intervention including an isolation ward, but had plausible alternative explanations, including generalised decline in MRSA observed in other hospitals at the same time. This led the reviewers to characterise these studies as presenting 'evidence' supporting control but not 'strong' evidence. The papers by Farrington and colleagues,⁹¹ Faoagali and colleagues,⁷⁶ Cox and colleagues⁸⁸ and Duckworth and colleagues⁸⁹ consisted of long time series, with detailed information on the interventions, and with the outcome measured at a large number of time points. In all but Cox and colleagues' study,⁸⁸ the changes observed were large. One, by Farrington and colleagues,⁹¹ systematically records potential confounders, which enables one to conclude that there was strong evidence that MRSA was controlled for many years, until the strain changed and or the numbers colonised on admission presented the institution with too great a challenge. Faoagali and colleagues' paper⁷⁶ presents 15 years evidence of over 5000 cases of MRSA and the bacteraemia data, in particular, were considered to provide stronger evidence of the failure of an IW to control MRSA. The data on infection in Duckworth and colleagues' paper⁸⁹ were considered to present stronger evidence of control of MRSA and that in Cox and colleagues' paper,⁸⁸ where the observed change was smaller was considered to present evidence of no control, although in both papers there was less treatment of potential confounders than Farrington and colleagues⁹¹ and Faoagali and colleagues' papers.⁷⁶

Designated nursing staff (NC) studies (Table 2)

Design

Of the nine studies, three were retrospective ITS^{101,105,113} of two, two and four phases, respectively. Two were prospective one-phase observational studies.^{94,104} One⁷⁹ was a

TABLE 2 NC studies

Study	Setting and study population	Design	Main interventions	Outcomes	Assessment of evidence
Arnou <i>et al.</i> , 1982 ⁷⁹	Burns unit (8 beds)	Hybrid retrospective (phase 1, 8.5 months), prospective (phase 2, 8.5 months) ITS	Phase 1: used barrier precautions only (assumed to be gloves and gowns) (phase 1). In phase 2: NC was introduced, together with handwashing education and increased screening	MRSA cases: 39 (phase 1); 6 (phase 2). No new cases occurred during periods when NC was complete	Study provides evidence supporting control by NC, and other interventions. Variation in patient bed days is a plausible alternative explanation and regression to the mean effects is possible
Back <i>et al.</i> , 1996 ¹¹³	Neonatal ICU (50 beds)	Retrospective ITS 4 phases: 2 months, 24 months, 22 months and 6 weeks	NC throughout. Changes to screening, topical eradication and ward closures	46 MRSA cases, 10 with clinical disease. Two outbreaks. The first ended following implementation of intensive screening and mupirocin therapy; the second ended shortly after screening intensified	NC failed to control the initial outbreak. Data are consistent with screening and mupirocin contributing to control. However, design is vulnerable to large reporting bias
Blumberg and Klugman, 1994 ⁸¹	ICU (20 beds), paediatric oncology (15 beds) and non-targeted areas of a tertiary care hospital (~3000 beds)	1-year cohort study with non-equivalent concurrent controls, 1-year historical controls and 1-year follow-up	No control measures before study (historical controls). During intervention year eradication, screening and patient isolation (single rooms and staff cohorting) used in ICU and paediatric oncology. Measures largely abandoned in follow-up year	299 MRSA bacteraemias (43 in areas with interventions). Bacteraemias fell in the intervention year in targeted areas, then rose to intermediate levels in the post-intervention year. They increased each year in non-targeted areas	Evidence supporting control by interventions. Regression to the mean effects likely, and study vulnerable to changes in LOS
Coello <i>et al.</i> , 1994 ¹¹⁸	Teaching hospital (1500 beds)	Prospective ITS. 3 phases: 8, 8 and 26 months. Phases and end-point not predefined	Phases 1 and 2: minimal isolation and screening. Phase 3: single-room isolation and NC; contact screening; prompt discharge of MRSA cases. Topical eradication with neomycin nasal cream in phase 1 and with mupirocin in phases 2 and 3	476 infected patients. Number of infections increased throughout phases 1 and 2, peaked at start of phase 3, then declined slowly to a very low level	Stronger evidence supporting control of a major outbreak by interventions. No information on many confounders
Girou <i>et al.</i> , 1998 ⁹⁴	Medical ICU in a university hospital (26 beds)	Prospective time series. One phase (4 years)	Single-room isolation and NC on closed bays; screening of patients at high risk of carriage; only minor changes during study	Newly identified MRSA cases: 293. Percentage of patients acquiring MRSA fell each year, while number colonised on admission changed little	Weak evidence consistent with control by interventions. Increasing patient turnover is an important confounder. Impossible to assess effect of isolation policy owing to lack of preintervention data

continued

TABLE 2 NC studies (cont'd)

Study	Setting and study population	Design	Main interventions	Outcomes	Assessment of evidence
Lugeon <i>et al.</i> , 1995 ¹⁰⁴	University hospital (1000 beds)	Prospective observational study (uninterrupted 4-year time series)	Policy was for increasing intensity of isolation (single rooms, cohorting, NC) until outbreaks were controlled. Screening and isolation of previous MRSA patients on readmission. No major changes to policy during study	100 MRSA colonisations; 25 infections. Pattern of spread characterised by occasional limited clusters and frequent sporadic cases not resulting in secondary spread	Evidence of regular introduction of MRSA and prevention of sustained transmission. Impossible to assess effect of isolation policy owing to lack of preintervention data
Mayall <i>et al.</i> , 1996 ¹¹⁹	Thoracic ward (35 beds)	Prospective ITS. 4 phases: 49, 45, 92 and 365 days. Phases and end-point not predefined	NC in phase 1, no isolation in phases 2–4. Progressively less screening in phases 2–4. Screening, handwashing education and topical mupirocin for all patients (regardless of MRSA status) throughout. No control measures prior to intervention	6 MRSA acquisitions; 47 colonised on admission. No major changes in any outcome measures throughout study	No evidence of different infection rates between phases, but change in prevalence and screening effort are important confounders
Oto <i>et al.</i> , 1992 ¹⁰¹	Neonatal unit (42 beds)	Retrospective ITS. 2 phases: 4 months each	Phase 1: no control measures. Phase 2: NC in closed bays, screening, eradication therapy, education	MRSA infections: phase 1: 30 phase 2: 17	Weak evidence consistent with reduction in transmission by combined measures. Large reporting bias likely with this type of study
Schlünzen <i>et al.</i> , 1997 ¹⁰⁵	General hospital (330 beds)	Retrospective ITS. 2 phases: 1.5 and 2 months	Phase 1: single room or cohort isolation. Phase 2: NC on closed bay	5 nosocomial cases in phase 1. None in phase 2 despite continued presence of MRSA cases	Weak evidence consistent with control by NC. Stochastic effects likely to be dominant, and large reporting bias likely to be associated with this type of study

retrospective/prospective two-phase ITS, one a prospective three-phase ITS,¹¹⁸ one a prospective four-phase ITS (formal systematic prospective data collection but unplanned interventions)¹¹⁹ and one a prospective cohort study with historical controls.⁸¹

Setting and population

Three studies were whole hospital studies,^{104,105,118} two were set in neonatal units,^{101,113} one in a medical ITU,⁹⁴ one in a thoracic unit¹¹⁹ and one in a burns unit.⁷⁹ One was set in an ITU and a paediatric oncology unit.⁸¹

Endemicity and epidemicity

In all but two studies,^{105,113} MRSA was endemic, although in one¹¹⁸ it was initially epidemic.

Size

One study consisted of five cases,¹⁰⁵ four of 45–53 cases,^{79,101,113,119} two of 100–300 cases,^{94,104} one of 299 bacteraemias⁸¹ and one of 1074 cases.¹¹⁸

Length of study

Three studies^{101,105,113} lasted <1 year, three between 1 and 3 years^{79,81,119} and three from 3.5 to 4 years long.^{94,104,118}

Comparators

Six studies^{79,81,101,105,118,119} compared a phase without NC with a phase with NC. Three studies had NC in all phases.^{94,104,113}

Results of NC comparator studies

Coello and colleagues' hospital study¹¹⁸ described 1075 cases of MRSA over 3.5 years, with a monthly time series that included infections, thus avoiding confounding attributable to any increased screening. This was the only single-room isolation and cohorting study in this review that designated nursing staff for all MRSA patients, and a major reduction in infections was seen after introducing this. The evidence that the combined interventions of NC for all MRSA patients in single rooms or cohorts, screening and eradication were responsible for the fall in MRSA levels was highly plausible. There were no obvious plausible alternative explanations, but some important confounders were not assessed. However, the strain type appeared to be constant and both seasonality and regression to mean appear unlikely from the time series data. As with other studies of this nature, it was not possible to assess the relative contribution of the elements of the control policy to the fall in MRSA.

Arnow and colleagues' report⁷⁹ provides evidence consistent with reduction of endemic MRSA by NC

in a burns unit, presenting weekly time series data over the 17 months of the study. Regression to the mean and variation in patient bed days (which correlated with the percentage of susceptible patients becoming colonised) provided plausible alternative explanations.

Blumberg and Klugman's study⁸¹ provided evidence consistent with reduction of bacteraemia, especially when units with the intervention were compared with the rest of the hospital, where bacteraemia rates progressively rose. Regression to the mean provided a plausible alternative explanation for the reduction between preintervention (phase 1) and intervention phases, as the units where interventions were made were chosen **because** they had unusually high MRSA levels. The lack of time series data makes the conclusions vulnerable to trends. The large increase in number of blood cultures performed in one intervention unit suggested an increased number of admissions, which might make the study vulnerable to changes in LOS.

Mayall and colleagues' study¹¹⁹ showed no increase in MRSA after stopping NC, but reduced screening and prevalence provided plausible alternative explanations. The lack of pre-NC data made it hard to draw any conclusion about the effectiveness of NC.

Schlünzen and colleagues' study¹⁰⁵ was a short, successful outbreak report of only five cases. Although it presents evidence consistent with control by NC, it was subject to the same limitations as those affecting similar studies involving IWs as discussed above. Oto and colleagues¹⁰¹ present weak evidence consistent with reduction in MRSA infection by NC in a neonatal unit, but the outcome data were recorded for each phase as a whole, so it does not allow any detection of trends. Seasonal effects provide a plausible alternative explanation and large reporting bias may also be anticipated with this type of study.

Results of non-comparator NC studies

In the 4-year study by Lugeon and colleagues,¹⁰⁴ isolation intensity increased according to the number of cases on a unit. NC was introduced when there were at least four related cases, as suggested by typing. There was no apparent trend in MRSA levels and the evidence was consistent with regular introduction of MRSA from outside sources and prevention of sustained transmission of single clones. It was not possible to assess the role of NC in particular in preventing spread from

the given data and there was no information on preintervention levels of MRSA. There was no apparent change in strain, nor was there clear evidence of seasonal effects, but information on other confounders was not recorded.

Girou and colleagues' study⁹⁴ on a medical ICU presented evidence consistent with control by NC and screening. A plausible alternative explanation was provided by the reduction in LOS, which raised the possibility that patients with MRSA acquired on the unit may not have detected it until after they had left the unit. The lack of preintervention data meant that it was impossible to assess whether there was a decreasing trend before the intervention or whether a decrease was seen only after introduction of NC.

Back and colleagues' report¹¹³ of successful control of two outbreaks on a neonatal unit, where NC was practised throughout, and control achieved following changes to the screening and eradication policies, is subject to the usual limitations of outbreak reports as discussed above. Interpretation of the time series of colonisation data is affected by the large increase in screening activity.

Conclusion: NC reports

Coello and colleagues' study¹¹⁸ of NC of patients isolated in single rooms or in cohorts was characterised as providing stronger evidence of control by NC. The time series was long, with sufficient time points, and there were a large number of MRSA cases. A large fall in MRSA incidence and infections was seen, for which there appeared to be no obvious plausible alternative explanation. However, some potential confounders were not assessed. As with all studies where multiple interventions were presented simultaneously, data were not reported or analysed in sufficient detail to allow an assessment of the relative contribution of different interventions.

Arnou and colleagues⁷⁹ and Blumberg and colleagues⁸¹ studies were characterised as providing evidence of control by NC, but plausible alternative explanations existed, such as regression to mean (both studies) and variation in patient bed days⁷⁹ and possible change in LOS.⁸¹ Arnou and colleagues' study⁷⁹ had good time series data, which strengthened the evidence. Blumberg and colleagues' study⁸¹ only presented data by phase, leaving it vulnerable to alternative explanations.

It was possible that early implementation of NC, as in successful small outbreak reports, might control MRSA. However, for the reasons stated above in the IW studies, it was difficult to be certain, and these studies were considered to present only weak evidence of control of MRSA by NC.

It was hard to derive information on the effect of NC from studies with no data comparing pre- and postintervention levels of MRSA.^{94,104} Of the two single-phase studies only Lugeon and colleagues¹⁰⁴ reported in sufficient detail to provide moderate evidence that a control programme that included NC as cases increased prevented the sustained spread of MRSA, despite regular introduction of MRSA from outside the hospital. It was not possible to draw any conclusion about the specific role of NC in this study. Girou and colleagues' study,⁹⁴ in contrast, was vulnerable to plausible alternative explanations for the apparent decrease in MRSA.

Other isolation policies reports (Table 3)

Design

Two studies were retrospective ITS with two phases, where the comparison was decided before examination of the data.^{56,78} Four were hybrid retrospective/prospective ITS with the first phase retrospective and the subsequent phases prospective.^{57,84,92,95} Five were prospective two-phase ITS.^{55,97,102,107,120} One was a prospective cohort study with historical controls,¹¹⁴ one a prospective cohort crossover study¹¹⁰ and one a prospective ITS.⁹³ There were four prospective single-phase observational studies.^{90,106,108,112} There was one retrospective cohort study based on systematically collected survey data with the comparison decided in advance of examination of the data.¹⁰⁹

Setting and population

Five studies were whole hospital studies^{56,92,106,112,120} and one dealt with two hospitals.¹⁰⁸ Twelve were studies in hospital units: ICU and general medical ward;^{57,78} medical and surgical ITUs;¹¹⁰ dermatology ward;⁹³ gastrointestinal surgery unit;¹¹⁴ colorectal surgical ward;¹⁰⁷ wound care unit;⁹⁷ surgical ICU;¹⁰² neonatal ICU;⁹⁵ paediatric ICU;⁸⁴ and one was of seven wards in a general hospital.⁹⁰ One studied patients with gastrointestinal diseases on two surgical wards.⁵⁵ One study was based on a systematically collected questionnaire survey of all reported index cases of MRSA in Dutch hospitals.¹⁰⁹

TABLE 3 Other isolation policies

Study	Setting and study population	Design	Main interventions	Outcomes	Assessment of evidence
Barakate <i>et al.</i> , 2000 ¹²⁰	Teaching hospital (1000 beds)	Prospective ITS. 2 phases: 12 and 18 months	Single-room and cohort isolation throughout. High-risk groups screened and MRSA patients excluded from some wards. Isolation of readmitted previous MRSA patients introduced in phase 2	995 new colonisations. No change in MRSA incidence or bacteraemia rates and MRSA remained endemic. Some wards could be kept MRSA-free	Evidence that isolation measures failed to prevent MRSA is consistent with data but insufficient colonisation on admission data for full assessment. Evidence of success in maintaining designated MRSA-free zones is weak owing to lack of screening in these areas
Barakate <i>et al.</i> , 1999 ¹⁰⁷	Colorectal surgical ward (28 beds)	Prospective ITS. 2 phases: 6 and 22 months	Side rooms and cohorting of MRSA patients throughout. Phase 2 interventions included ward closure, cleaning and automatic alerts for prompt isolation of readmitted MRSA patients	MRSA cases: 20 (phase 1); 64 (phase 2). No noticeable change in MRSA incidence. MRSA remained endemic	Effect of isolation policy unclear as no preisolation phase. Evidence is consistent with the failure of ward closure, cleaning and automatic alerts to reduce MRSA, but interpretation difficult without prevalence data and information on other confounders
Cosseron-Zerbib <i>et al.</i> , 1998 ⁸⁴	Paediatric ICU (20 beds)	Hybrid retrospective (phase 1, 21 months) and prospective (phase 2, 24 months) ITS	Phase 1: screening for last 11 months. Phase 2: single-room isolation, cohorting, screening, feedback, handwashing education, barrier nursing, chlorhexidine soap and other measures	MRSA infections: 50 (phase 1); 6 (phase 2). MRSA infection incidence showed a sharp reduction after intervention and remained at a low level	Stronger evidence supporting conclusion that interventions reduced MRSA infections. Regression to mean and Hawthorne effects supply less plausible alternative explanations
Esveld <i>et al.</i> , 1999 ¹⁰⁹	Dutch hospitals with index MRSA cases responding to a questionnaire (231 returned questionnaires)	2-year retrospective cohort study based on systematically collected survey data	Two cohorts defined by isolation policy. Isolation cohort: index cases isolated on admission according to Dutch guidelines. Non-isolation cohort: other isolation policy or delayed isolation	Isolation cohort: 4 out of 73 cases led to secondary spread. Non-isolation cohort: 19 out of 95 cases led to secondary spread. Odds ratio (95% CI): 4.3 (1.3 to 18.2)	Study provides evidence that immediate patient isolation contributed to control. Several other plausible explanations exist. These include differences in strains (isolation was strongly associated with strains originating abroad), differences in characteristics of cohorts and settings and potential bias introduced by differential response rates to questionnaires

continued

TABLE 3 Other isolation policies (cont'd)

Study	Setting and study population	Design	Main interventions	Outcomes	Assessment of evidence
Girou <i>et al.</i> , 2000 ⁹³	Dermatology ward (16 beds)	Prospective before and after study. 2 phases: 8.5 and 7.5 months	Single-room isolation and cohorting throughout. Phase 1: admission screening targeted at patients at high risk of carrying MRSA. Phase 2: admission screening for all patients	10 MRSA acquisitions in phase 1; 8 in phase 2. Similar numbers of MRSA carriers detected by both screening policies	Insufficient data to assess impact of isolation policy. Evidence that yield of admission screening is greatly increased by screening only high-risk patients
Harbarth <i>et al.</i> , 2000, ⁹² Pittet <i>et al.</i> , 2000 ⁸⁰	Teaching hospital (1300–1600 beds)	Hybrid retrospective and prospective ITS. 3 phases: 4, 2 and 3 years	Phase 1: no control measures. Phase 2: single-room isolation, screening, mupirocin. Phase 3: as phase 2 + hand-hygiene education and feedback programme	1771 MRSA colonisations and infections. 158 bacteraemias. Incidence of total MRSA and bacteraemias increased each year in phase 1. Stabilised in phase 2, then fell sharply, especially in phase 3	Stronger evidence supporting control by interventions. Some potential confounders, but these provide less plausible explanations for the changes
Hartstein <i>et al.</i> , 1997 ¹⁰⁸	Two teaching hospitals (A and B) with mean daily patient censuses of ~250–280 and ~230–250, respectively	Non-comparative prospective 18-month observational study	Single-room isolation, handwashing education and glove use for MRSA patients at both hospitals. No changes during study	MRSA acquisitions: 48 (hospital A); 22 (hospital B). MRSA was continuously introduced to both hospitals throughout study. Only sporadic transmission resulted	Effect of isolation policy unclear as no preisolation phase. Weak evidence that interventions maintained low levels of MRSA, but no recording of potential confounders
Jernigan <i>et al.</i> , 1996 ⁹⁵	Neonatal ICU (33 beds)	Hybrid prospective and retrospective ITS (2 phases). Phase 1 (12 days) retrospective, phase 2 (~9 months) prospective	Phase 1: contact isolation (gloves, gowns, masks and use of 2-bedded side room if possible). Additional measures in phase 2: eradication from selected patients; weekly screening; handwashing education	Total cases: 16 (5 in phase 1, 11 in phase 2). Large fall in incidence after additional control measures. Relative risk of transmission from an unisolated compared with an isolated source (95% CI): 15.6 (5.3 to 45.6), $p < 0.0001$	Evidence supporting reduction in MRSA transmission by isolation measures. Potential bias as no blinding to the isolation status of patients when assessing transmission sources. Regression to the mean effects possible

continued

TABLE 3 Other isolation policies (cont'd)

Study	Setting and study population	Design	Main interventions	Outcomes	Assessment of evidence
Kac <i>et al.</i> , 2000 ⁹⁷	Wound care centre (51 beds)	Prospective ITS. 2 phases: 3 months and 2 years	Phase 1: no measures Phase 2: gowns and gloves for wound contact, handwashing education, feedback of infection rates, MRSA wounds dressed last.	15 wound infections. Reduction in proportion of patients acquiring MRSA wound infections from 6/70 (9%) to 9/583 (1.5%)	Evidence that control measure reduced infection rates, but limited by short baseline with possibility of seasonal effects and vulnerable to pre-existing trends (due to lack of time series data). Impossible to distinguish cross-infection and autoinfection
Landman <i>et al.</i> , 1999 ⁵⁶	Teaching hospital (~500–600 discharges per month)	Retrospective ITS. 2 phases: 29 and 23 months. Comparison not suggested by data	Change to antibiotic formulary in phase 2. No isolation or screening throughout	Mean monthly incidence of MRSA infections per 1000 discharges (SD): 21.9 (8.9) phase 1; 17.2 (7.2) phase 2	No assessment of effect of isolation possible. Evidence of slight reduction in infection incidence after antibiotic policy change. Approximately 20% reduction in patient bed days and shorter LOS provide plausible alternative explanations
Onesko and Wienke, 1987 ⁵⁷	ICU (10 beds) and general medical ward (40 beds)	Retrospective (phase 1) and prospective (phase 2) ITS (1 year each phase)	Phase 1: non-medicated soap . Phase 2: low-iodine soap. Strict or contact isolation throughout (gloves, gowns, masks and single-room isolation if possible)	Total number of hospital-acquired MRSA infections fell from 25 (phase 1) to 5 (phase 2)	No assessment of effect of isolation possible. No evidence that change in soap controlled MRSA as decline in incidence predated change by 3 months. Regression to mean effects likely
Papia <i>et al.</i> , 1999 ¹⁰⁶	470 Acute care beds in a teaching hospital (1100 beds)	Prospective non-comparative study	Single-room isolation, screening of patients at high risk of carriage on admission. No changes to these during study	1.3% of high-risk patients positive on admission. Transmission rate per colonised patient: 0.048/day	No assessment of effect of isolation possible. High risk of sampling bias affecting estimate of those positive on admission. Likely misclassification of those colonised on admission as new acquisitions, so transmission rate may be an overestimate
Pfaller <i>et al.</i> , 1991 ¹¹²	General hospital (327 beds)	Phase 1 (1 month): prospective non-comparative study. Phase 2 (6 weeks): unplanned outbreak report	Phase 1: single-room isolation. Systematic admission and discharge screening to assess MRSA transmission. Phase 2: single rooms and cohorting. Contact screening to control outbreak	13 cases in phase 1; 11 in phase 2. Comparable numbers of transmission events in each phase (4 in 1 month in phase 1; 7 in 1.5 months in phase 2), although unlike phase 1, those in phase 2 were mostly from the same plasmid type	No evidence that transmission rates differed between phases, or that changes in screening and isolation contributed to control. Reporting bias for phase 2 data

continued

TABLE 3 Other isolation policies (cont'd)

Study	Setting and study population	Design	Main interventions	Outcomes	Assessment of evidence
Ribner <i>et al.</i> , 1986 ¹¹⁰	32-bed SICU and 20-bed SIMU	Prospective cross-over cohort study with predefined protocol. Two 2-month phases, two settings	Isolation either strict (single-room isolation when possible, with masks, gloves, gowns), or modified precautions (masks and gloves only unless high-risk MRSA patients when single rooms and gowns used as well)	Total acquired cases: 20. Similar numbers of MRSA acquisitions during strict isolation and modified precautions (11 and 9, respectively)	Weak evidence that interventions are of comparable efficacy. Power of study likely to be low, and study vulnerable to trends and 'contamination' between phases
Souweine <i>et al.</i> , 2000 ⁷⁸	ICU (10 beds)	Retrospective ITS. Comparison not suggested by data. 2 phases: 1 year each	Phase 1: no control measures. Phase 2: gloves and gowns, admission and weekly screening, eradication, handwashing education, prompt patient discharge, antibiotic restriction	MRSA infections fell from 12 (phase 1) to 6 (phase 2)	Weak evidence supporting reduction in infection by interventions. Vulnerable to trends. Stochastic effects likely to be dominant. Reduced LOS is a possible confounder
Talon <i>et al.</i> , 1995 ¹⁰²	Surgical ICU (15 beds)	Prospective ITS. Phase 1: 4 months. Phase 2: 2 months	No isolation but screening on admission and weekly throughout. Introduction of topical mupirocin for all patients in phase 2	Phase 1: 35 nasal isolates. Phase 2: 6 nasal isolates. For predominant strain: SICU acquisitions 12 (phase 1) and 1 (phase 2)	No assessment of effect of isolation possible. Weak evidence that intervention reduced nasal acquisition of MRSA. Limited time series and risk of selective reporting as time series for only 1 of the 7 strains is given
Tambic <i>et al.</i> , 1999 ⁹⁰	7 wards in a teaching hospital. 633 patients admitted during study	Prospective 1-month non-interventional study	No intervention. MRSA patients cohorted on closed bays throughout. Systematic screening to measure MRSA prevalence	42 MRSA cases. 22 MRSA-positive patients (52%) had no infections	No assessment of effect of isolation possible. Evidence that substantial proportion of MRSA carriers would not be detected without active screening
Yano <i>et al.</i> , 2000 ¹¹⁴	Surgical department (~80 beds). Gastrointestinal surgery patients (<i>n</i> = 128, phase 1; <i>n</i> = 141, phase 2)	Prospective cohort study with historical controls. Phase 1 (control). Phase 2 (intervention), each 12 months	Mupirocin used postoperatively for all study patients in phase 2, regardless of MRSA status. Single-room isolation and cohorting for MRSA cases. Preadmission screening throughout	Phase 1: 9 and 6 postoperative MRSA and MSSA infections. Phase 2: 0 and 1 postoperative MRSA and MSSA infections	No assessment of effect of patient isolation is possible. Evidence supporting control of MRSA infections by intervention. Vulnerable to trends, Hawthorne effects and stochastic fluctuations

continued

TABLE 3 Other isolation policies (cont'd)

Study	Setting and study population	Design	Main interventions	Outcomes	Assessment of evidence
Yoshida <i>et al.</i> , 1995 ⁵⁵	Patients with gastrointestinal diseases (<i>n</i> = 994) on two general surgical wards	Prospective ITS. Two 1-year phases	Single-room isolation. Ward round order changed in phase 2 so that MRSA patients were visited last	150 MRSA infections in phase 1; 50 in phase 2. Continuous stable MRSA incidence for first 10 months of phase 1; no new cases for last 2 months of phase 1. Slightly lower incidence for most of phase 2	No assessment of effect of single-room isolation possible. Evidence consistent with reduced incidence of infection due to intervention. Apparent reduced prevalence in last two preintervention months could provide a plausible alternative explanation
LOS, length of stay; SD, standard deviation; SICU, surgical intensive care unit; SIMU, surgical intermediate care unit.					

Endemicity and epidemicity

In one study,⁹² MRSA was epidemic and became endemic. One study considered multiple temporally limited outbreaks (epidemic MRSA).¹⁰⁹ One study considered epidemic MRSA.⁹⁵ In the remainder, MRSA was endemic.

Size of studies

Ten studies had <50 MRSA cases or infections,^{57,78,90,93,95,97,102,110,112,114} four had between 50 and 100,^{84,106,108,120} one involved 200 infections,⁵⁵ one included 483 isolates¹⁰⁹ and three comprised 500–1800 cases.^{56,92,120}

Length of studies

Five studies^{90,95,102,110,112} lasted <1 year (range: 1–9 months); 12 lasted between 1 and 4 years^{55,57,78,84,93,97,106–109,114,120} one lasted 4 years 4 months⁵⁶ and one study described 9 years' experience of MRSA.⁹²

Comparators

In five studies the comparisons were made between periods with and without isolation policies (usually accompanied by other control measures). The isolation policies were single-room isolation,⁹² single-room isolation and cohorting without designated staff⁸⁴ and gowns and gloves (with other general IC measures) for MRSA patients.⁷⁸ One other study also introduced gowns and gloves (with other general IC measures) but this applied to all patients, not just those with MRSA,⁹⁷ and in one report the policy changed from single-room isolation to single-room isolation and cohorting.¹¹²

In eight studies there was a constant isolation policy of single-room isolation and, in three of these, cohorting.^{93,107,120} The interventions here were changes to other aspects of MRSA control such as the criteria for isolation,^{110,120} change in screening policy,⁹³ ward closure, cleaning and alert systems,¹⁰⁷ eradication, screening and hand-hygiene education,⁹⁵ a change of soap,⁵⁷ use of mupirocin for all patients irrespective of MRSA status¹¹⁴ or leaving MRSA patients until last on ward rounds.⁵⁵ In the study by Jernigan and colleagues,⁹⁵ although the intervention was not a change to patient isolation, the data were reported and analysed in sufficient detail to allow an assessment of the contribution of the isolation to control.

In two studies with no isolation policy throughout, the intervention was a change in antibiotic usage⁵⁶ and mupirocin use for all patients irrespective of MRSA status.¹⁰²

Three studies were one-phase observational non-comparative studies with cohorting⁹⁰ or single-room isolation throughout.^{106,108} One study compared secondary spread from isolated and non-isolated index cases.¹⁰⁹

Results where comparator was isolation policy

The most relevant of these studies to a review of isolation policies were those where the isolation policy changed from none to single room,⁹² from none to side room and cohorting⁸⁴ and from none to use of gowns and gloves,^{78,97} and the two studies where there was no change in isolation policy but data were recorded in sufficient detail to allow an assessment of the impact of patient isolation.^{95,106}

In Harbarth and colleagues' study,⁹² 1771 new cases of MRSA were reported in 9 years, including 158 MRSA bacteraemias. A long time series was presented, with sufficient time points to identify trends. For the first 4 years, no control measures were in place and the total incidence of new MRSA cases and MRSA bacteraemias numbers rose rapidly. The first 2 years of single-room isolation, together with screening and eradication, saw total MRSA rates stabilise and MRSA bacteraemia rates start to fall. The addition over the next 3 years of a hand-hygiene programme with documented improved compliance coincided with a yearly fall in MRSA bacteraemias rates, to less than one-third of the preintervention peak, and in total MRSA rates to less than half of a preintervention peak. The relatively high levels of total MRSA in the first 3 years of the intervention were partly explained by the large increase in screening. There was no such difficulty in interpreting MRSA bacteraemia rates. The paper assessed many potential confounders. There was a reduction in LOS, increased admissions and higher occupancy, all of which are adjusted for in the analysis to some extent by using rates per 100 admissions and per 1000 patient days, and by giving the relative risk of MRSA acquisition.

There was a change in antibiotic use (increase in extended spectrum β -lactams, reduction in aminoglycoside and augmentin). Such a change does not appear to provide a very plausible alternative explanation for the reduction in MRSA as increased use of extended spectrum β -lactams might be expected to increase MRSA levels.³⁸ The evidence that the combined interventions were responsible for this reduction was therefore highly plausible, as was the evidence that the hand-hygiene programme produced a sustained increase in compliance.⁸⁰ It was plausible that this

improved compliance played an important role in controlling MRSA. However, it was not possible to assess the relative contributions of the different elements of the control policy.

Cosseron-Zerbib and colleagues⁸⁴ 3.75-year study of 56 MRSA infections in a paediatric ICU presented data as a 6-monthly time series and assessed potential confounders such as the number of admissions, staffing levels, bed occupancy and liver transplants (which doubled from 10 to 20%, and might be expected to increase MRSA infections). Changes in bed occupancy and number of admissions were partially adjusted for by use of appropriate denominators. Infection rates fell sharply after the change from no isolation to single-room isolation and cohorting, with weekly screening, feedback and other measures. It was not possible to know which element contributed most to the fall. Regression to the mean and Hawthorne effects might provide alternative explanations. However, the consistency of the higher incidence over a sustained period before, and lower incidence after, the intervention make the possibility of this fall being a coincidence a less plausible explanation.

In the study by Jernigan and colleagues,⁹⁵ although there was no major change in the patient isolation policy, the authors recorded data in sufficient detail to permit an assessment of the amount of transmission from isolated and unisolated infants. These assessments were made independently by two observers based on temporal and spatial data, and 100% concordance between observers was achieved. Here isolation was in accordance with 1983 Center for Disease Control and Prevention (CDC) guidelines for contact isolation, which included gloves, gowns, masks and side rooms when available. The authors concluded that the rate of transmission from unisolated sources was more than 15 times greater than that from isolated sources [relative risk 15.6 and 95% confidence interval (CI), 5.3 to 45.6]. This provided evidence to support the efficacy of such isolation measures. However, the evidence was weakened by the lack of any reported blinding of those assessing sources of transmission events to the isolation status of infants. Also, the fact that the interventions in phase 2 (changes to handwashing, eradication and screening) were made in response to a large number of cases in phase 1 also suggested that regression to the mean effects could be inflating the apparent effect of patient isolation.

Esveld and colleagues' study¹⁰⁹ was based on routine systematically collected questionnaire

surveillance data, retrospectively examined to determine whether secondary spread from index cases was less likely when the index case was isolated immediately and managed according to the Dutch National Guidelines. Guidelines include single-room negative-pressure isolation of cases and of patients awaiting screening results, eradication, hand-hygiene, gloves and gowns. The authors found that the odds ratio for secondary spread from patients isolated late or not managed according to national guidelines was 4.3 (with exact 95% CI recalculated by reviewer (BC) as 1.3 to 18.2; $p = 0.007$, from a two-sided Fisher's exact test). This provides evidence to support the efficacy of such measures. However, strain differences might offer a plausible alternative explanation: patients with local Dutch strains were less likely to be isolated on admission than those with foreign strains, and there was more spread from local Dutch strains than from foreign strains. This may be *because* of the isolation policy, as suggested, but it could also be due to differences in properties of the strains themselves. Thus, if local strains are more transmissible than foreign strains, this could provide an alternative explanation for observed differences in transmission from isolated and unisolated patients. Another alternative explanation is that those hospitals that isolate immediately according to national guidelines may differ in other respects, such as better hand-washing and staff-patient ratios. The study design allowed a 5-month window in which to identify clusters so may be more likely to detect falsely transmission of local strains. As patients with these tended to be those who were not isolated immediately, this could also bias the results. A further limitation is that only 78% of hospitals with secondary cases returned the questionnaire and that in only 76% of index cases could isolation status be determined. Nonetheless, the study design avoids many potentially large biases associated with reporting and regression to the mean effects, and bases its conclusions on a comprehensive sample.

In the two studies that changed from a policy of no isolation to using gowns and gloves,^{78,97} the evidence was consistent with combined infection control measures reducing MRSA infections. However, in the study by Souweine and colleagues⁷⁸ the large reduction in LOS between phases provided an alternative plausible explanation. Although this was part of the intervention, this could also bias the results owing to a reduced chance of detecting infections during the patient admission.

Stochastic effects were also likely to be important, and lack of time series data left the study vulnerable to trends. For the study by Kac and colleagues,⁹⁷ the major limitation was the very limited preintervention data. The single data point prevented assessment of trends and left the study vulnerable to seasonal effects.

Results with non-isolation policy comparators

Studies with a background isolation policy

In Barakate and colleagues' paper,¹⁰⁷ the main intervention was ward closure, cleaning and electronic flagging of readmitted patients previously known to have had MRSA. This was conducted against a background of single-room isolation and cohorting. There was no evidence of changes in MRSA incidence over the 28-month study, but interpretation was difficult without prevalence data. There were insufficient data to allow an assessment of the effect of the isolation policy on MRSA levels.

Barakate and colleagues' later study¹²⁰ used single-room isolation and cohorting with screening of high-risk groups throughout, with certain wards not permitted to admit MRSA patients. The intervention was the isolation of patients with a past history of MRSA on readmission. There was no evidence of a change in MRSA incidence or bacteraemia rates throughout the 30-month study. The evidence was consistent with failure of single-room isolation, cohorting and screening to control MRSA. However, the absence of prevalence or numbers colonised on admission prevented a fuller assessment of this. Also, no assessment of the role these measures may have played in reducing MRSA transmission was possible. The authors concluded that it was possible to keep some wards clear of MRSA, but the absence of screening on these wards prevented our assessment.

Onesko and Wienke's study⁵⁷ of change to a medicated soap (chosen because its lower potential to induce skin irritability was thought likely to improve hand-hygiene compliance) did not provide evidence consistent with control of MRSA. The monthly time series showed that there were steady reductions in MRSA in the 3 months before the intervention. Regression to the mean provided a plausible alternative explanation. No assessment of the effect of isolation could be made from this study.

Pfaller and colleagues reported¹¹² a short (1-month) prospective non-comparative study of single-room isolation. This showed only four

acquisitions from 473 patients screened on admission and discharge. This was followed by a 1.5-month outbreak report of a small cluster of related cases, managed by single-room isolation, cohorting and contact screening. This occurred after the study period and was reported not because it was part of the study, but because it was a cluster that was apparently controlled by these measures. The usual caveats regarding reporting bias and, on the basis of data from the planned part of the study, stochastic effects apply.

Ribner and colleagues' prospective cohort cross-over study¹¹⁰ compared two isolation policies: one included masks, gowns, gloves, and single-room isolation (when possible) for all MRSA patients (strict isolation); the other used masks and gloves only, with the addition of gowns and single-room isolation only for selected high-risk patients (modified isolation). This study provided no evidence of a difference in outcomes between the two isolation regimes. However, the study lasted only 4 months, had only 20 new MRSA cases and was likely to have very low power to detect a difference.

The design also left it vulnerable to trends and washout effects. Furthermore, even though this was a planned study, the study populations were chosen in part because of their above-average MRSA levels. If such higher levels were due, in part, to stochastic fluctuations, a decrease would be expected during the study (regression to the mean), confusing the interpretation of the results. As this was such a short study (4 months), this effect was potentially important.

Yano and colleagues' study¹¹⁴ of the effect of giving mupirocin to all patients, against a background of single-room isolation and cohorting for MRSA patients, and pre-admission screening, provided evidence consistent with reduction of infection by this means. However, the numbers are small, with nine postoperative infections in the historical controls and none in the treatment cohort. Lack of time series data left the study vulnerable to other plausible explanations such as trends and stochastic fluctuations (fadeout) and Hawthorne effects. There are case mix differences, with more preoperative complications in the treatment cohort, but this was not likely to provide a plausible alternative explanation. No assessment of the effect of patient isolation was possible.

Yoshida and colleagues' 2-year two-phase study⁵⁵ of the effect of changing the order of ward rounds

so that the MRSA patients were seen last, against a background of single-room isolation, provided evidence consistent with reduction of MRSA infections from 150 cases in the first year to 50 in the second. However 2 months before the intervention there was a prolonged period with no new cases. This might have been associated with reduced prevalence and therefore a smaller MRSA reservoir, providing a plausible alternative explanation for the reduction. A fuller assessment of this intervention would therefore require the prevalence data. No assessment of the effect of side-room isolation could be made from this study.

Studies with no background isolation policy

Although Landman and colleagues' study⁵⁶ provided evidence consistent with a slight reduction in MRSA infections after implementing an antibiotic policy, the reduction in both the LOS and the numbers of admissions resulted in an estimated 20% reduction in patient bed days, which was an important confounder. The relevance of this study to the review was limited as there was no isolation or screening policy.

Talon and colleagues' study¹⁰² of the effect of mupirocin given to all patients in a surgical ICU with no isolation, but a screening policy, was also of limited relevance to a review of the isolation policy. Although evidence was consistent with control of nasal acquisition of MRSA, seasonal effects provided a plausible alternative explanation. The study was limited because the acquisition data presented only one of the seven MRSA strains that appeared to be transmitted on the ward.

Non-comparator studies

Hartstein and colleagues' 18-month study¹⁰⁸ of single-room isolation, with eradication and hand-hygiene education in two hospitals, provided evidence consistent with maintenance of endemic MRSA at low levels. However, there was no screening, and no recording of any potential confounders, so the data were difficult to interpret and no assessment of the effect of isolation was possible. It was similarly impossible to assess the effects of single-room isolation in Tambic and colleagues' 1-month observational study.⁹⁰ The only conclusion that can be drawn was that a substantial proportion of MRSA carriers would not be detected without active screening.

The aim of Papia and colleagues' 12-month observational study of single-room isolation and

screening¹⁰⁶ was to determine the cost-effectiveness of screening all patients at high risk of MRSA carriage on admission. It was assumed that all other cases of MRSA were hospital acquired. The transmission rate per colonised patient per day was calculated and the costs of the screening programme compared with the costs of managing MRSA. Important costs were overlooked (for example, nursing costs, and those incurred by differential LOS) and estimates of the cost of IC measures appeared to be based on arbitrary assumptions. As low-risk patients were not screened on admission, some of those later found to have MRSA might have been colonised on admission, resulting in an overestimate of the transmission rate. A significant number of high-risk patients were not screened on admission, thus introducing potential sampling bias, affecting the estimate of those colonised on admission. Although the paper reported numbers of cases in the year prior and the year after the study, it gave no details of isolation and screening policies for these periods. No time series data were given for the year of the study, and few potential confounders were recorded. Interpretation of the effect of the interventions on control of MRSA is therefore not possible.

Conclusions: other isolation policies

Harbarth and colleagues' work⁹² was characterised as providing 'stronger' evidence that an effective hand-hygiene programme, allied to single-room isolation, screening and eradication, could reduce MRSA levels and serious invasive infection even when initially at a high level. Although alternative explanations cannot be ruled out, they do not appear to be particularly plausible.

Cosseron-Zerbib and colleagues' study⁸⁴ was characterised as providing stronger evidence that the interventions (single-room isolation, cohorting, weekly screening, feedback and other measures) explained the fall in MRSA. There was a long time series, detailed information on interventions and recording of many potential confounders. Although alternative explanations were possible, they did not seem very plausible.

Jernigan and colleagues' study⁹⁵ was characterised as providing evidence supporting control by contact isolation with gowns, gloves and masks, and use of two-bedded side rooms when possible, comparing the likelihood of transmission from isolated and non-isolated infants. Although the detail provided and the size of the effect made other explanations less likely, the study design had some weaknesses.

Other studies either provided no evidence that could be used to assess the effect of an isolation policy, or were weakened by study limitations, potential biases or confounding factors.

Economic evaluation

There was a paucity of data on the economic impact of MRSA infections or the interventions. The identification of the resources used was imprecise and of limited range and the estimation of the costs of these resources was poor. In general there was little comprehensive and consistent economic information. Only 15 studies presented quantitative cost data. In most cases only selected resources used for the infection control measures were costed, although four studies provided more detailed costings of control programmes.^{31,92,119,105} One study attempted to quantify cost savings associated with an intervention⁵⁷ and one study¹⁰⁶ attempted to assess the cost-effectiveness of a screening programme. Both concluded their interventions were likely to be cost-effective. However, we found the evidence supporting these conclusions to be weak or lacking.

No comprehensive comparable costing data were available on key variables. Some studies, for example, would provide the costs of screening in great detail, whereas others identified cost of antibiotics⁵⁶ or costings for labour and materials used in molecular typing.¹⁰⁸ Some researchers were more ambitious, attempting to cost the whole outbreak or intervention. Harbarth and colleagues,^{80,92} for example, estimated costs for microbiology, surveillance and contact isolation, concluding that the cost of the total infection control programme was almost Swiss Francs (SF) 3–4 million to the institution. Many others made comments about the lost resources that had resulted from the outbreak, such as bed days lost.⁷⁵ Other studies referred to the impact on waiting lists and emergency admissions. Given that the estimates provided ranged widely over time, location and the range of costs included, direct comparisons of the costs of control measures could not be made. Thus, despite the awareness of the economic implications of MRSA and the control measures, there was no robust economic evaluation.

Overall conclusions of literature review

In about one-third of the studies in this review, it was impossible to draw any conclusions about the

effect of isolation. Most of the remaining studies reported evidence consistent with control (i.e. reduction) of MRSA. The evidence in about half of these was characterised as weak, because of poor experimental design, clear alternative explanations (LOS, seasonal or stochastic effects, regression to the mean, regional changes or antibiotic use) or likely reporting bias.

In most studies with weak or even no evidence of reduction of MRSA, it was not possible to say whether the levels of MRSA might have been even higher without the intervention, because of lack of control populations.

The majority of studies used combinations of interventions such as screening, eradication and an isolation policy, and it was not possible to assess the relative contribution of different elements of the control policy. Full interpretation of studies requires occurrence (incidence or prevalence) data and information on numbers of colonised patients on admission, together with reporting of potential confounders. This was illustrated well by the studies reported by Farrington and colleagues⁹¹ and Murray-Leisure and colleagues.⁸³ The lack of comprehensive, consistent and robust economic evaluation in the literature meant it was not possible to comment on the cost-effectiveness of any study or type of intervention.

The strongest evidence was considered to come from the larger and longer time series, with large changes in MRSA, an adequate number of time points to assess trends, detailed information on interventions and absence of plausible alternative explanations (*Figure 7*). Thus Harbarth and colleagues' papers^{80,92} were considered to present relatively strong evidence that side-room isolation, screening and eradication therapy, with a hand-hygiene programme including audit, feedback and education, reduced MRSA colonisation and infection. Stronger evidence was also presented by Farrington and colleagues⁹¹ that an IW, together with screening, eradication and ward closures, could control MRSA for many years until a change in epidemic strain or a rise in those colonised on admission provided an overwhelming challenge to the hospital. Faoagali and colleagues⁷⁶ presented stronger evidence of failure of an IW, screening, antibiotic restriction and hand-hygiene education to prevent a huge rise in MRSA colonisation and infection. Duckworth and colleagues' paper⁸⁹ provided stronger evidence that MRSA infection could be reduced by an IW with screening and eradication, although some potential confounders were not documented. The same applies to Coello

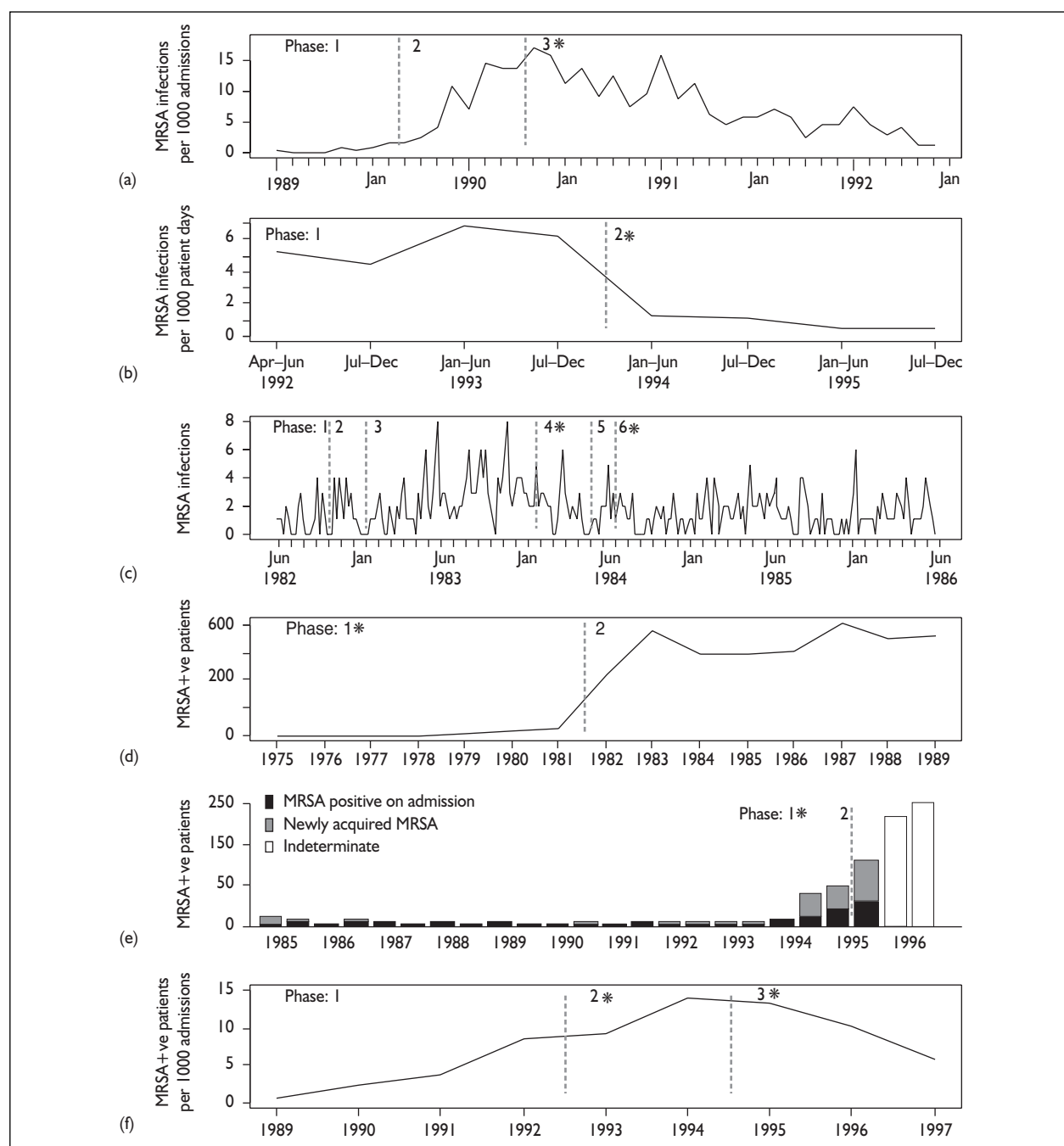

FIGURE 7 Outcome of studies considered to present the strongest evidence. ITS for (a) Coello and colleagues¹¹⁸; (b) Cosseron Zerbib and colleagues⁸⁴; (c) Duckworth and colleagues⁸⁹; (d) Faoagli and colleagues⁷⁶; (e) Farrington and colleagues⁹¹; (f) Harbath and colleagues.⁹² Tables 1–3 give explanatory text for each study. Asterisks indicate phases with most intensive isolation policies. In (d) and (e) isolation policies in both phases were similar (IW), but in the second phase the capacities of the IWs were exceeded in both cases, and the overflow was cohorted or isolated in single rooms.

and colleagues' report¹¹⁸ of the efficacy of NC in side rooms. Cosseron-Zerbib and colleagues⁸⁴ presented stronger evidence of a reduction in infection attributable to single-room isolation and cohorting, with other measures.

Five studies with characteristics similar to those listed above were considered to present evidence

of reduction of MRSA by an IW (Selkon and colleagues,⁸² Murray-Leisure and colleagues⁸³), reduction by NC (Arnow and colleagues,⁷⁹ Blumberg and Klugman⁸¹) or of failure of an IW (Cox and colleagues⁸⁸) but with plausible alternative explanations (Selkon and colleagues,⁸² Murray-Leisure and colleagues,⁸³ Arnow and colleagues,⁷⁹ Blumberg and Klugman⁸¹) or with

smaller changes in MRSA and failure to record some important potential confounders (Cox and colleagues⁸⁸). Jernigan and colleagues' study⁹⁵ of transmission from isolated and unisolated infants provided evidence that immediate side-room isolation reduced transmission but was potentially biased. Esveld and colleagues' study¹⁰⁹ provided similar evidence for the general population but plausible alternative explanations and potential biases existed.

Although the short outbreak reports which use IW or NC to reduce MRSA have many plausible alternative explanations of outcomes and may be

subject to reporting bias in that negative outcomes are less likely to be written up or published, it is still possible that immediate deployment of NC or an IW may have been successful in eradicating MRSA and preventing epidemics from becoming endemic.

Those studies with the strongest evidence provide testable hypotheses for future prospective studies. Taken as a whole, the studies covered by this review emphasise the need to collect adequate data, including data on the resources used and their cost, sufficiently frequently to enable the effectiveness and cost-effectiveness of interventions to be fully interpreted.

Chapter 5

Modelling of transmission dynamics and economics of control of MRSA by patient isolation

This chapter presents:

- a mathematical model of the long-term dynamics of MRSA in a hospital population that takes into account patient readmission patterns
- a modified version of this model that considers the effects of using patient isolation as a control strategy
- an economic evaluation of the cost-effectiveness of control strategies using different patient isolation and screening strategies, based on the above model and available economic data.

Rationale

The object of the work presented in this chapter was to develop simple mechanistic models able to account for the observed MRSA dynamics from the longer time series studies found in the review. Such models are intended to provide insight into the dynamics and the conditions under which isolation policies can be effective at controlling MRSA in both the short term and the long term. They are not intended to be used as predictive tools. We first present a model that ignores control measures, and then modify this by adding an isolation ward which is assumed to be effective at reducing transmission from isolated patients.

No single study provided sufficient data to estimate all the parameters; instead, parameter values were estimated from diverse sources as detailed below. We explored the sensitivity of results to variations in parameters relating to control measures and transmission rates.

We then combined these models with economic data to provide an economic assessment of the use of isolation wards compared with a policy of no intervention. In the absence of reliable data regarding the attributable costs of MRSA, any such assessment is necessarily very crude. Although accurate cost assessments cannot be made with the available data, such an analysis does permit order of magnitude estimates, allows us to identify the

key unknowns affecting costs, and provides a framework for further economic analysis when better data become available.

Background

Published mathematical models of nosocomial pathogens, such as MRSA, have to date largely addressed dynamics within single wards.^{51,72,121–125} This work has addressed conditions for persistence, interactions between antibiotic-sensitive and resistant organisms and antibiotics and stochastic effects. However, these models fail to explain observed patterns of hospital spread of MRSA in two important respects. First, although existing models explain rapid short-term increases in prevalence and incidence of MRSA, as it approaches a stable endemic level, they cannot account for the more frequently observed pattern of a relatively slow increase over several years as seen in many of the longer time series studies in the literature review. Second, they fail to explain why MRSA is able to persist in hospital populations in many situations. All deterministic dynamic models predict that persistence is possible provided that a critical threshold is reached: each infected or colonised patient must transmit the organism to, on average, at least one other patient in the absence of other infected/colonised patients. However, in many real settings these threshold conditions appear not to be met, and there is insufficient transmission for persistence to occur as predicted by these single ward models. Even when threshold conditions are met, stochastic effects should dominate in the small populations represented by hospital wards and chance fadeouts should bring such local epidemics to an end. Nevertheless, MRSA certainly does persist in hospitals; even though the organism may not be endemic on any single ward, a common pattern identified in the review is for transmission to be characterised by frequent but limited clusters on different wards.¹⁰⁴

Other observations not explained by such models include changing numbers of patients colonised on admission and changes in the ratio of

incidence of hospital-acquired cases to cases colonised on admission.^{91,126}

The models presented in this chapter are therefore motivated by key qualitative aspects of the longer time series studies that existing models cannot account for. In particular, they aim to be able to capture the observed trends of MRSA numbers and reported changes in the number of imported MRSA cases.⁹¹ A further motivation is the observation that control failure was associated with isolation resources becoming overwhelmed in two of the isolation ward studies, characterised in the literature review as providing stronger evidence.^{76, 91}

Model without patient isolation

Modelling assumptions and model formulation

Models presented in this chapter are based on modified versions of those described previously.⁵¹ The major change is that patterns of patient readmissions are considered explicitly and no specific assumptions about transmission routes are made.

The basic model presented here assumes a constant homogeneous hospital population of n patients, y of whom are considered to be colonised or infected with MRSA at any time, and who are able to transmit infection. The remaining x (equal to $n - y$) are free of MRSA. We also assume a constant community population size, where all deaths are replaced by births.

In this model, all MRSA transmission takes place in the hospital. No explicit assumptions about the transmission route are made, but new cases are assumed to occur at a rate proportional to the product of the number of colonised/infected and uncolonised patients in the hospital (the mass-action assumption). The duration of carriage of MRSA is assumed to be exponentially distributed, with a mean length of carriage of $1/d$ days. Rather than explicitly considering loss of MRSA positive individuals through mortality or emigration, we consider these sources of loss to be absorbed into the rate of carriage loss, d . No distinction is made between colonised and infected patients in this basic model (and, in the interests of brevity, we will refer to colonised or infected individuals as colonised).

Throughout the results we refer to a single parameter, the basic reproduction number, R_0 .

This is a composite measure of the transmissibility, and can be defined as the average number of secondary cases produced by one case introduced into a hospital completely free of infection. This measure takes into account the possibility of multiple hospital episodes while the patient is still colonised. If the infection is to cause a major epidemic or to persist in the absence of control measures, then R_0 must be >1 .

When discharged from the hospital, patients are assumed to go into a class of recently hospitalised patients of whom x_c are free of MRSA and y_c are colonised. These individuals then have some chance of readmission in any given time interval, specified by another parameter, μ_H . While in this class, the time to readmission is assumed to be exponentially distributed with a mean of $1/\mu_H$ days. However, after a time, if not readmitted, patients move to another compartment, with a longer mean time to readmission of $1/\mu_L$ days. There are assumed to be y'_c colonised and x'_c MRSA-free individuals with these lower admission rates. The time patients spend with an elevated admission rate after discharge is itself assumed to be exponentially distributed, with a mean duration of $1/\gamma$ days before the admission rate is reduced. These assumptions produce a pattern of readmission such that individuals either return relatively rapidly to hospital or else have a longer period in the community without entering hospital.

This model is illustrated schematically in *Figure 8*.

Implementation details

Two formulations of the model were used: a deterministic formulation, which can be considered to approximate the mean behaviour of the model, and a stochastic formulation, where transitions between model compartments (for example, from uncolonised to colonised and from hospitalised to community-based) are random events, with the chance of an event occurring specified by model parameters. Implementation details of these formulations are given in Appendix 4.

Parameter values

Parameter values were estimated from the best available sources, as identified during the search strategy of the systematic review and additional literature searches. Where there was large uncertainty in parameters, we used a wide range of plausible values. No published estimates of readmission rates could be found, and these were

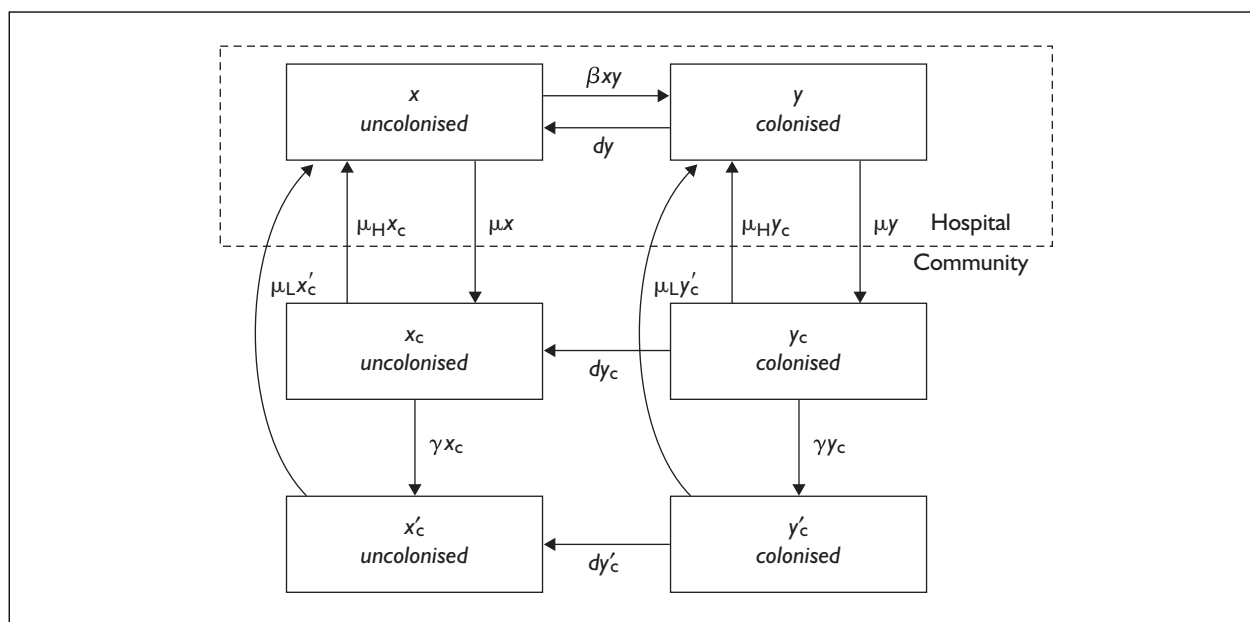

FIGURE 8 Flow diagram for the basic model (no control measures). Parameter values are listed in Table 4. Implementation details are given in Appendix 4. The total hospital and community population sizes are assumed to be constant. Birth and death are not explicitly considered in the model, but the contribution of mortality to loss of carriage can be considered to be absorbed into the parameter d , the rate of loss of carriage.

estimated from one year's data from the Royal Free Hampstead NHS Trust. Admission and discharge dates were obtained from all patients who were either admitted or discharged between 1 January and 31 December 2000 (excluding day cases, dialysis, obstetrics and psychiatry patients). These data consisted of 29,315 unique patient episodes. Of these episodes, 6502 were of patients who had previously been admitted in the same period. Maximum likelihood estimates for parameters were obtained using the annual data. These data were also used to compare (using the likelihood ratio test for nested models) the model with two rates of readmission (as described above) with a simpler model based on a single readmission rate. Details are given in Appendix 4.

Results

Parameter values

Estimated parameter values for the readmission rates in the model with high and low readmission rates are shown in Table 4, while in the simpler model the readmission rate μ' (95% CI) was estimated to be 0.00152 (0.00148 to 0.00156). The likelihood ratio test showed that the model with two rates of readmission provided a much better description of the data ($p < 10^{-5}$), and this model was therefore used in all subsequent work. Estimated parameters give a period with an elevated rate of readmission lasting on average

just over 1 month. The low rate of readmission, μ_L , corresponds to an average of one admission every 4.5 years. The estimate for the initial readmission rate, μ_H , is just over 10 times greater, with an average of one readmission every 25 weeks.

We were able to find comparatively little information about the persistence of the carriage of MRSA in discharged patients in the community. Most of those studies that did describe rescreening of previously positive MRSA patients reported data in insufficient detail to allow estimates to be made.^{104,127,128}

Two studies were found that did allow estimates.^{129,130} The data reported by Sanford and colleagues¹³⁰ consisted of 36 readmitted patients who were known to have carried MRSA when discharged at the end of their previous episodes. The data showed good agreement with the assumption that durations of carriage were exponentially distributed, and the maximum likelihood estimate (95% CI) for the rate of loss of carriage, d , with these data was $d = 0.00085 \text{ days}^{-1}$ (0.00047 to 0.00138). This corresponds to a mean duration of carriage of 1190 days and a half-life for carriage of 825 days. The major limitation of these data, however, is that in only a minority of cases was there evidence that paired isolates from patients during different hospital episodes

TABLE 4 Parameters used in the models

Parameter	Symbol	Value	Reference
Transmission rate ^a	β	Range: 0.00007–0.00013	–
Isolation rate	φ	Range: 0.02–0.04	–
Clearance rate (day ⁻¹)	d	0.0027	129
Discharge rate (day ⁻¹)	μ	0.125	Royal Free 2000 data
Readmission rate – high	μ_H	0.0057; 95% CI: 0.0054 to 0.0060	Royal Free 2000 data
Readmission rate – low	μ_L	0.00063; 95% CI: 0.00058 to 0.00068	Royal Free 2000 data
Rate of change from high to low readmission rate	γ	0.030; 95% CI: 0.027 to 0.033	Royal Free 2000 data
Mean length of stay in isolation ward (days)	l/μ_i	20	131
Number of beds in hospital	N	1000	–
Number of beds in isolation ward	n_i	Range: 5–40	–
Number of individuals in community	n_c	~180,000	Defined by other parameters
Proportion of isolated patients cleared	π	25%	131

^a Transmissions per source per susceptible patient day.

represented the same strain. Typing, however, was based on restriction analysis of plasmid DNA. This method is vulnerable to loss of plasmids, and it is not possible to tell how often changes in strain type represented loss (or acquisition) of plasmids, and how often patients had lost one strain and acquired another.

Scanvic and colleagues¹²⁹ presented a larger data set, with 78 readmitted patients who had been MRSA positive on discharge. The median duration of carriage (or half-life) was estimated to be 8.5 months. Assuming an exponential distribution for carriage durations, the mean length of carriage can be estimated as the half-life divided by $\ln 2$, or 12.3 months. This corresponds to a rate of loss of carriage $d = 0.00268 \text{ days}^{-1}$.

Although both estimates for carriage duration are potentially biased in that they estimate carriage duration in individuals who are readmitted, they are the best data available. Also, since our primary concern is with hospital rather than community MRSA levels, this potential bias is not a major concern.

Direct estimates of MRSA transmission rates were not attempted. Such rates may be expected to vary widely according to local conditions and strains, and estimates from a single setting may not generalise to the average rate for a whole hospital required in the model. Instead, we considered a wide range of values for this parameter able to account for the diverse patterns of behaviour observed.

Model output

Figure 9 presents results from the deterministic model without isolation for three levels of transmissibility. It shows the changes with time in the hospital prevalence, community prevalence and the ratio of the incidence of new hospital-acquired cases to number of cases colonised on admission.

Although not apparent from the figure, of the three transmissibilities only the highest ($R_0 = 1.43$) allows persistence without reintroductions, with each patient causing an average of 1.02 secondary cases per episode in a completely susceptible population (taking into account multiple episodes, each patient causes 1.43 secondary cases on average, from the definition of R_0). For the lower R_0 values, there would be insufficient transmission to allow persistence without reintroduction, with an average of only 0.90 and 0.78 secondary cases per episode.

The figures show that when persistence is possible, MRSA numbers in both the hospital and the community may be expected to grow sigmoidally to a stable endemic level. Both the level of endemicity reached and the time taken to reach it are dependent on the transmission rate, but slow rates of growth are seen for smaller R_0 values, with numbers steadily increasing over many years. Similar patterns are seen in both the hospital and community populations, although there is a lag between the hospital and community growth curves (so, for example, the time taken to reach a prevalence equal to 50% of the final level is greater in the community than in the hospital population).

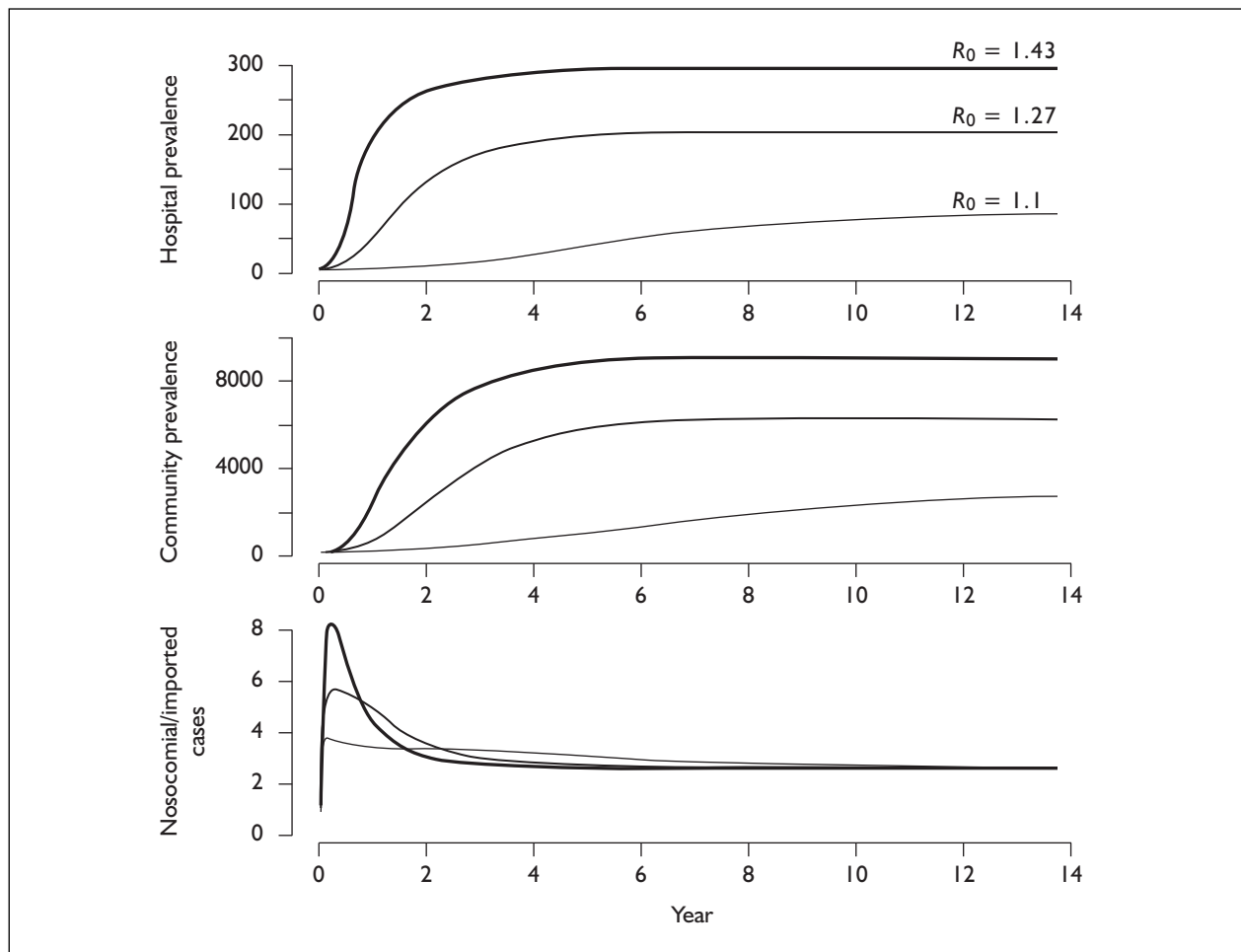

FIGURE 9 Deterministic solutions to the basic model without patient isolation. Solutions under three levels of transmissibility are presented (corresponding to the three R_0 values shown): $\beta = 0.0001$, 0.000115 and 0.00013 . Other parameters were set to default values.

The bottom graph in *Figure 9* shows the ratio of incidence of new nosocomial cases to imported cases. This is clearly initially dependent on R_0 , and could be used to estimate the R_0 value from data. However, as both hospital and community prevalence increase, the ratio declines to a constant level independent of the transmission rate.

Figure 10 shows output from a stochastic version of the same model for the two lower R_0 values. The behaviour is comparable to that seen in the deterministic version, with similar trends and endemic levels, but is a more accurate reflection of what is likely to be seen in real populations. Although the long-term trend is increasing, the prevalence does not increase smoothly, but undergoes a series of increases and decreases. Decreases can be substantial and sustained over periods from several months to a year. The other fundamental difference is that fadeout can now occur, i.e. the prevalence can fall to zero. Thus, for

the lower level of transmissibility, in at least 10% of the simulations the prevalence is zero at almost every time point. Even for the higher level of transmissibility, the hospital prevalence is close to zero during the first 4 years in at least 10% of simulation runs. Although the hospital prevalence is approximately zero, there may still be cases in the community, and when these are reintroduced subsequent outbreaks can occur. This accounts for the long-term persistence of the organism at a low level and explains why the 10th percentile line for $R_0 = 1.27$ increases only after an extended period at a very low level. These results show that a percentage of small outbreaks can be expected to end of their own accord (by chance), but even when this occurs there may be an eventual large outbreak triggered by readmitted colonised patients. The long times to readmission and long persistence of MRSA colonisation mean that the time between a hospital being 'seeded' with MRSA, and the time at which numbers begin to increase may be large (several years). It is not

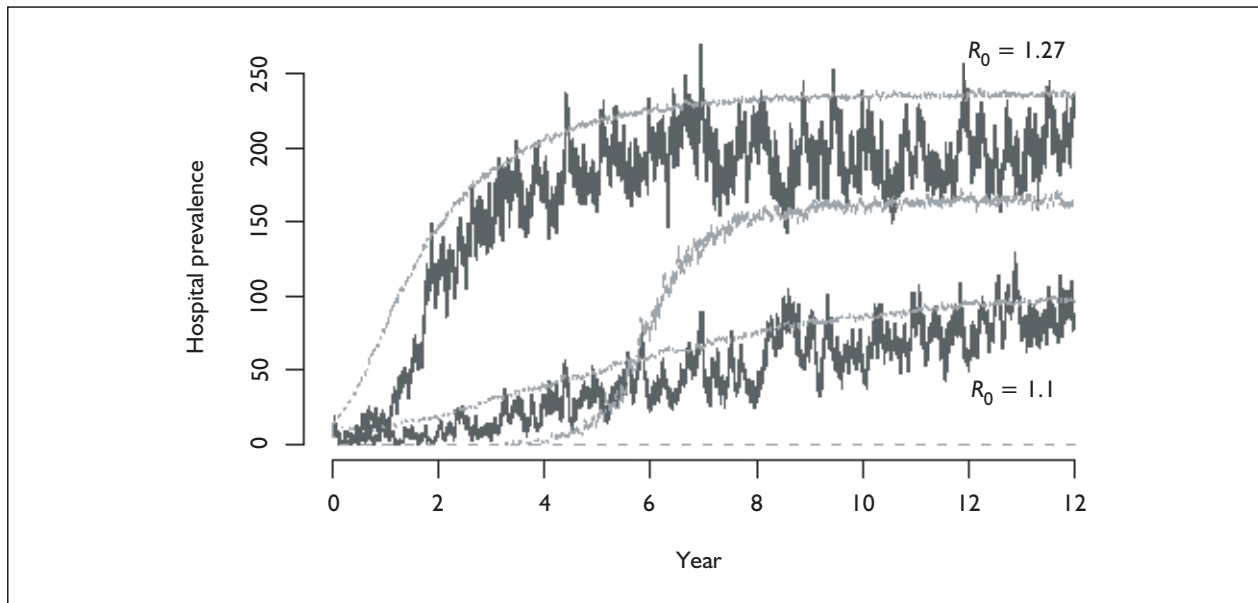

FIGURE 10 Stochastic solutions to the basic model without patient isolation for two levels of transmissibility. Heavy lines represent single simulation runs and fainter lines indicate the prevalences on the lowest 10% and highest 90% of simulation runs (10th and 90th percentiles) under both scenarios (calculated from 1000 simulation runs). For the lower level of transmissibility ($R_0 = 1.1$) the 10th percentile is 0 over almost the entire period, indicating that over 10% of simulation runs faded out early. Other parameters were identical in both sets of simulations, and simulations were started with 10 colonised patients in the hospital (and none in the community).

necessary to postulate differences in hospital practices to account for such variation in times of onset, or indeed to explain why some outbreaks fade out shortly after they have begun whereas others lead to the establishment of a stable endemic state.

Model with patient isolation

To consider the effect of isolation policies on control, we modified the basic model to include the effect of a policy based on the use of an IW. This measure has clear *a priori* validity, that is, based on what is known about MRSA transmission routes we can be reasonably confident that a well-designed IW with designated staff will prevent almost all transmission from isolated patients to those elsewhere in the hospital. For other isolation measures, such as single-room isolation, the evidence is, at best, ambiguous, and there is no clear face validity. However, the modelling framework presented here could be readily adapted to consider such measures.

Modelling assumptions and model formulation

In the new model there are a variable number, z , of isolated patients at any one time, and these

patients are not the cause of any secondary spread. All isolated patients are discharged to the community, with some fraction of them cleared of MRSA carriage on discharge. Unisolated, colonised patients in the hospital are detected at a rate, φ , and the mean time before a colonised patient is detected is $1/\varphi$. The mean duration in the IW is $1/\mu_i$, and times are exponentially distributed. Colonised patients are isolated as soon as they are detected. However, since the IW has a fixed capacity, n_i , when it is full the maximum rate at which patients can be isolated is equal to the rate at which other patients leave the isolation ward.

This revised model is illustrated schematically in *Figure 11*.

The equilibrium endemic prevalence of MRSA infection in the hospital is dependent on three parameters: the detection rate (φ), the size of the isolation ward (n_i) and the transmissibility of infection within the hospital (R_0). *Figure 12* shows the effect of these three parameters and demonstrates that an IW always has a positive effect in that it reduces transmission and consequently prevalence. This holds whether the IW is in operation throughout (a), or whether it is introduced only when there is already a stable endemic level (b). There are two types of

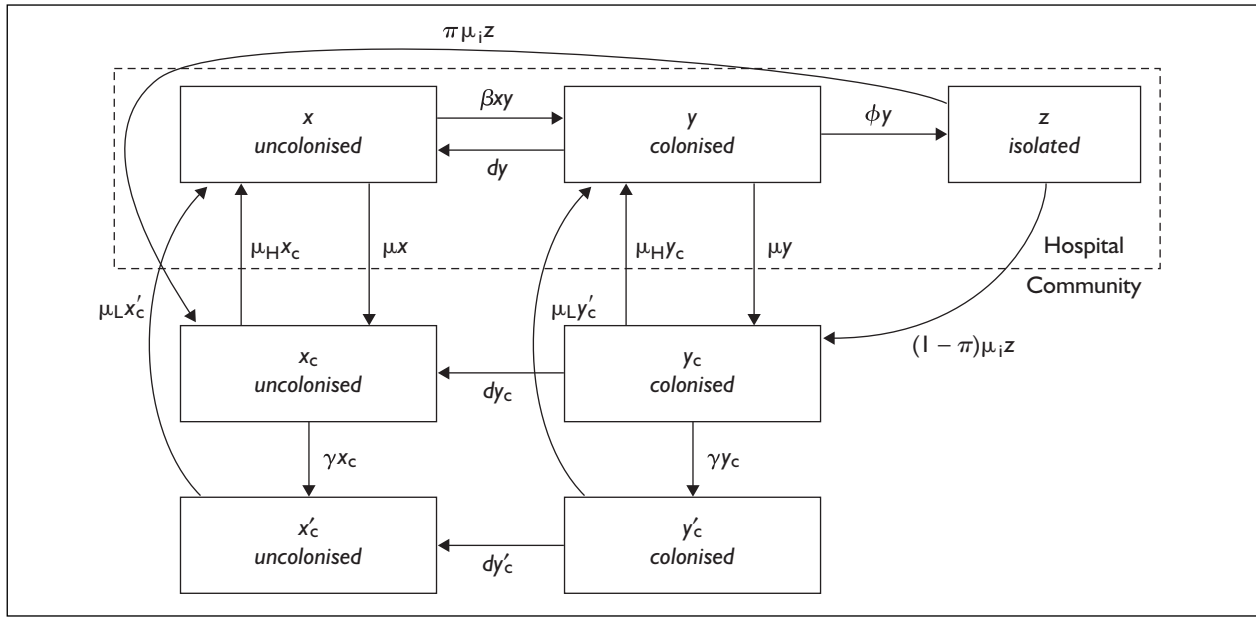

FIGURE 11 Flow diagram of model with patient isolation. Parameter values are listed in Table 4. Implementation details are given in Appendix 4.

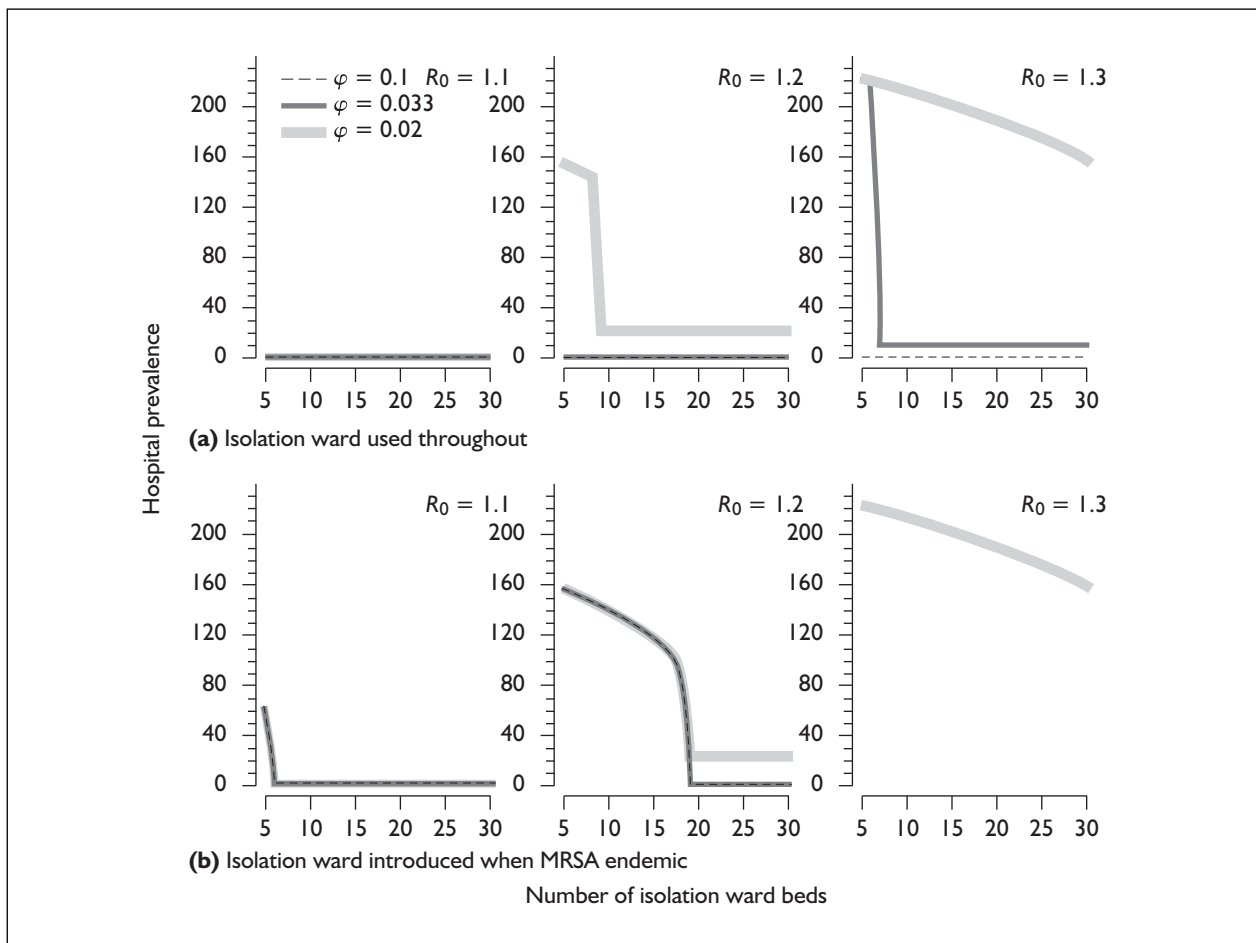

FIGURE 12 Effect of number of IW beds on equilibrium prevalences, when MRSA patients are isolated. In (a), the IW is introduced at the same time as the first MRSA case. In (b), the ward is introduced when MRSA levels are close to the equilibrium prevalence without isolation. Results are shown for three values of the mean times to detection of colonised patients: 10, 30 and 50 days (corresponding to $\phi = 0.1, 0.033, \text{ and } 0.02$). The three R_0 values were selected by varying the transmissibility, β (0.0001, 0.000109, 0.000118). Without isolation, stable prevalences would be 93, 212 and 303, respectively.

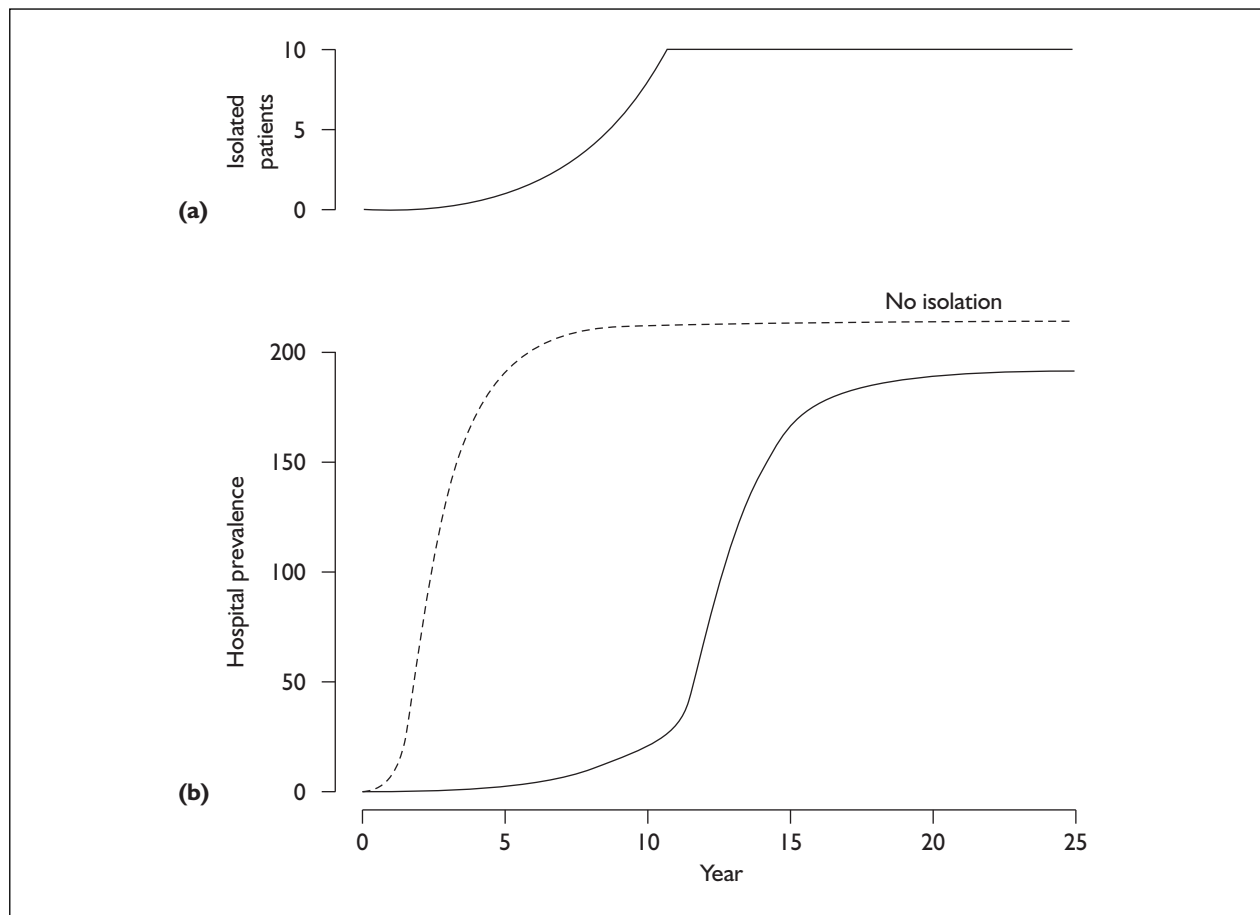

FIGURE 13 Isolation in a 10-bed IW. $R_0 = 1.27$; isolation rate $\varphi = 0.02$.

behaviour indicated by the slopes of the lines in *Figure 12*. First, when detection is not fast enough or the IW is not large enough, the organism is able to persist endemically. Improving either the detection rate or isolation capacity results in a decrease in endemicity (i.e. the lines are sloping downwards). Second, if either the detection rate or the isolation capacity is sufficient, then transmission is effectively determined by the other factor. Thus, when the detection rate is the limiting factor, the lines are horizontal, showing that increasing the number of isolation beds makes no difference, whereas increasing the detection rate lowers the prevalence. When only the number of isolation beds is the limiting factor, increasing the detection rate has no effect (and the lines are no longer horizontal, as increases in the number of isolation beds reduce the prevalence). In some cases both the size of the isolation ward and the isolation rate are limiting factors and prevalence is reduced by increasing either. This is seen for $R_0 = 1.3$ and $\varphi = 0.02$, when the IW is used throughout. Both the rate at which the IW is filled and its capacity determine the final endemic level.

Another important result demonstrated in *Figure 12* is that the final endemic level attained can depend on whether the isolation ward is operated from the start (a) or whether it is introduced to control endemic MRSA (b). In many cases, operating the isolation ward from the start is effective at preventing an endemic level from becoming established, whereas introducing it into an endemic situation is able to reduce but not eliminate the endemic level. For some parameter values different endemic levels may be reached depending on when the ward is introduced. Thus, although the early introduction of the IW still fails to prevent endemicity, it does reduce the final endemic level attained.

Figure 13 illustrates the colonisation dynamics when the detection and isolation rate are not high enough to prevent an endemic level from being established. *Figure 13(a)* shows that the number of patients in the isolation ward remains below capacity for a long period (~ 10 years). During this time the prevalence is much reduced (*Figure 13(b)*). However, when the IW reaches capacity, its utility is greatly diminished and the prevalence increases,

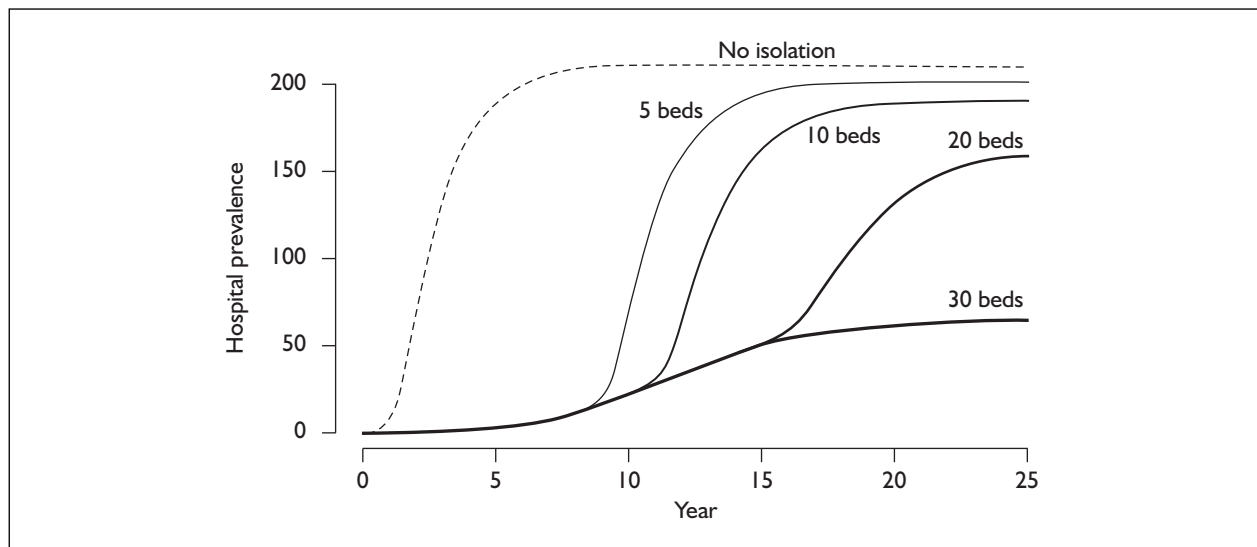

FIGURE 14 Effect of changing the size of the IW on the dynamics. IW in operation from year zero, with initially one hospital and one community case. $R_0 = 1.27$; isolation rate $\varphi = 0.02$.

although at a slower rate and to a lower level than would have occurred without any isolation. Consequently, even though isolation ultimately fails to prevent endemic MRSA, it still prevents a large number of colonisations and infections.

The effect of IW capacity is illustrated in *Figure 14*, which is drawn with the same detection and isolation rate as *Figure 13*. Clearly, the larger the capacity, the longer is the delay until it is overwhelmed, the slower is the increase when it is overwhelmed and the lower is the endemic prevalence achieved. If the capacity is sufficient (in this case 30 beds), then it can prevent the establishment of a high endemicity, principally because it is not full, that is, the ability to control is limited by the detection rate.

Figure 15 shows the effects of introducing a 30-bed IW at different stages of an MRSA epidemic. In *Figure 15(a)*, the detection rate is insufficient to reduce transmission and endemicity to minimal levels. However, early introduction of isolation (at years 0–3) results in a far lower prevalence over a sustained period than a later introduction. The lower level is achieved when the IW is no longer full, and endemicity is determined by the detection rate. If the IW is opened at year 4, there is sufficient detected prevalence that it reaches capacity almost immediately. Once the IW is full, its ability to control infection is compromised. For these parameters, however, even if opened after 4 years, a 30-bed IW is sufficiently large that prevalence is slowly reduced, and eventually (after about 30 years) the same endemic level is reached.

In *Figure 15(b)*, the same effect is occurring, but the higher detection rate is able to control infection to a minimal level. Again, the IW has spare capacity at the lower level. However, the upper level is unchanged by increasing the detection rate, since the limitation of the effectiveness of control is provided by the size of the IW, and this is always full over the period shown (although again, eventually prevalence is low enough so that the IW is no longer full, the rate at which colonised patients can be isolated increases, and prevalence then decreases more rapidly to a minimal level).

With the parameters in *Figure 15*, the same endemic equilibria are eventually reached, irrespective of the timing of the opening of the IW, although this has a large effect on the rate at which the final levels are reached. For certain parameter values, however, different equilibria are possible. The existence of the two endemic equilibria is shown in *Figure 16*. Note that the upper equilibria are the same regardless of the detection rate: they are determined by the IW capacity. Increasing the ability to detect infection increases the range over which it is possible to control MRSA at the lower, minimal endemic level. Which level is reached depends on the timing of the opening of the ward.

Figure 17 shows that stochastic effects can also be important in determining the ultimate endemic level. Three simulation runs from a model where a five-bed isolation ward is used from the start are shown. All models used identical parameters; only

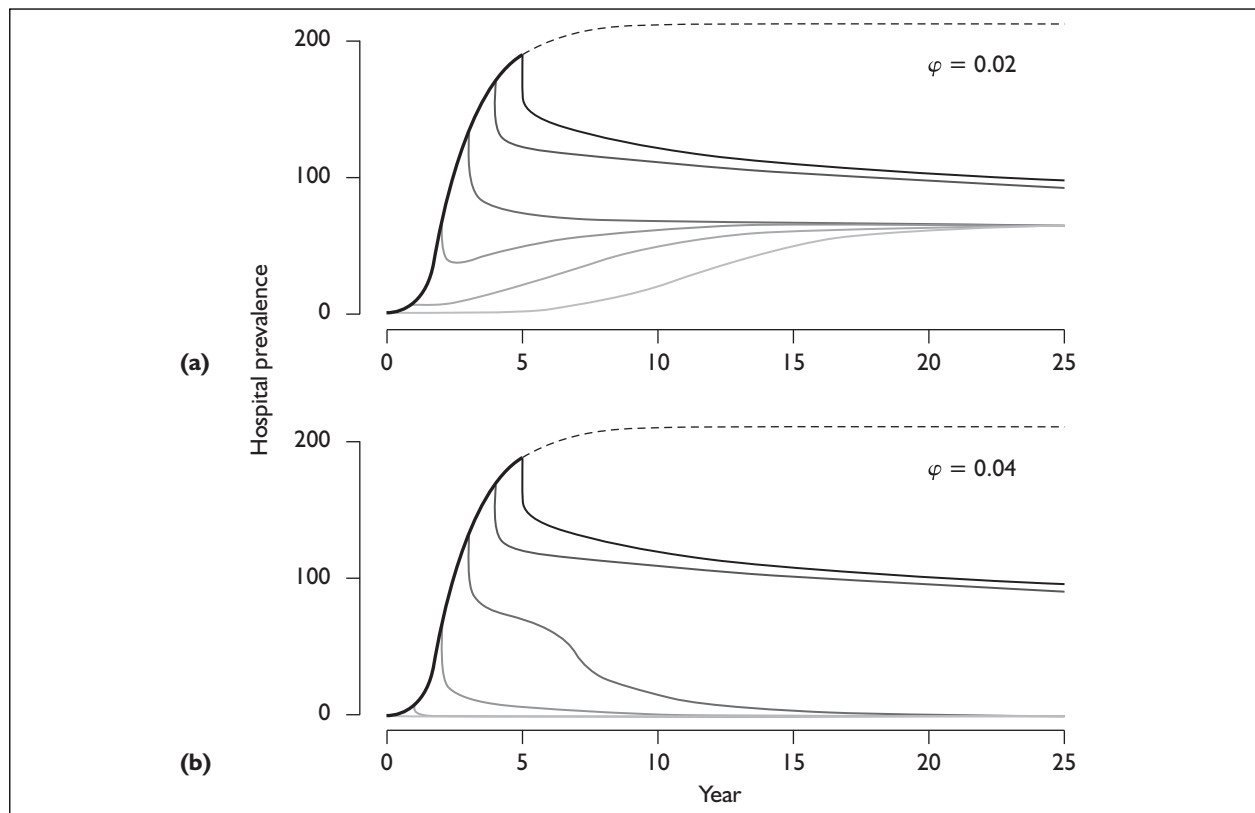

FIGURE 15 Thirty-bed IW opening 0, 1, 2, 3, 4 and 5 years after start of outbreak. $R_0 = 1.27$ without isolation and $\varphi =$ (a) 0.02 and (b) 0.04 (and initially one hospital and one community case).

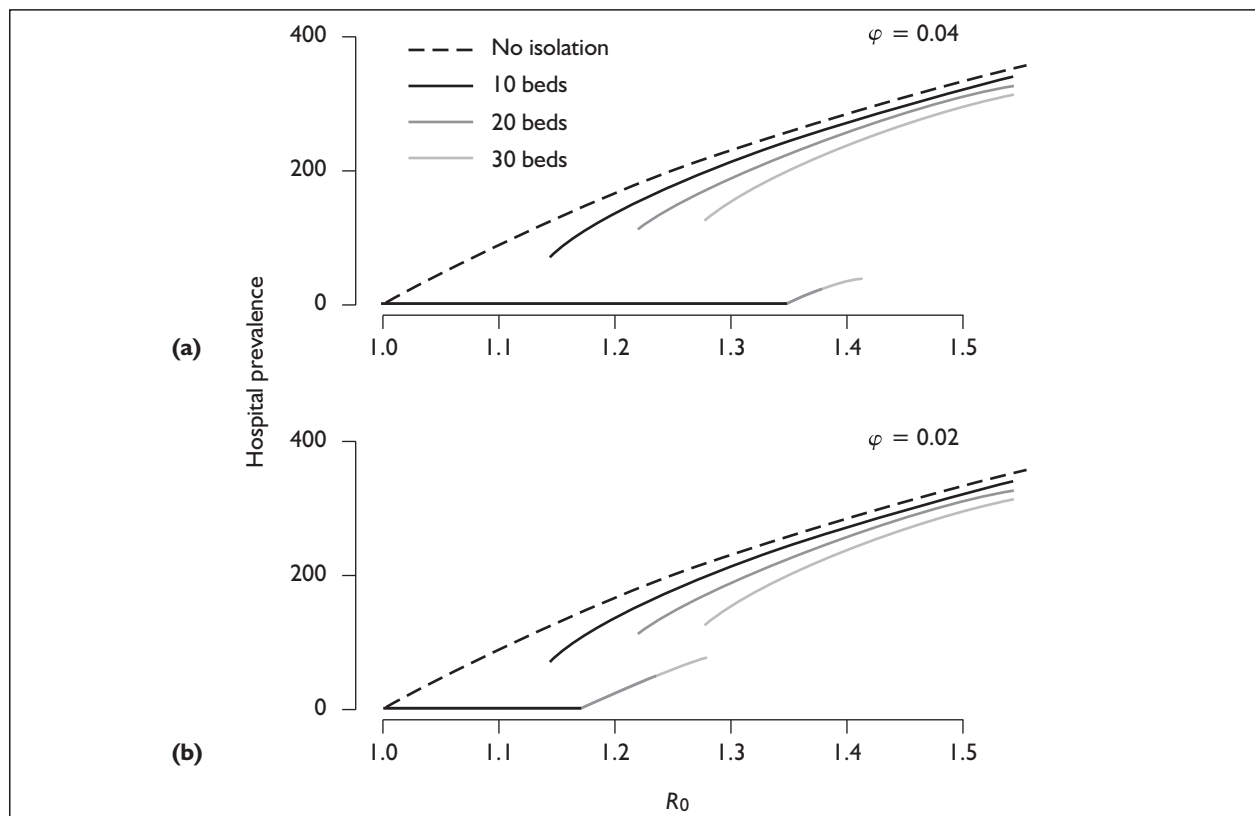

FIGURE 16 Stable equilibrium prevalences for different values of the basic reproduction number, R_0 , and $\varphi =$ (a) 0.04 and (b) 0.02

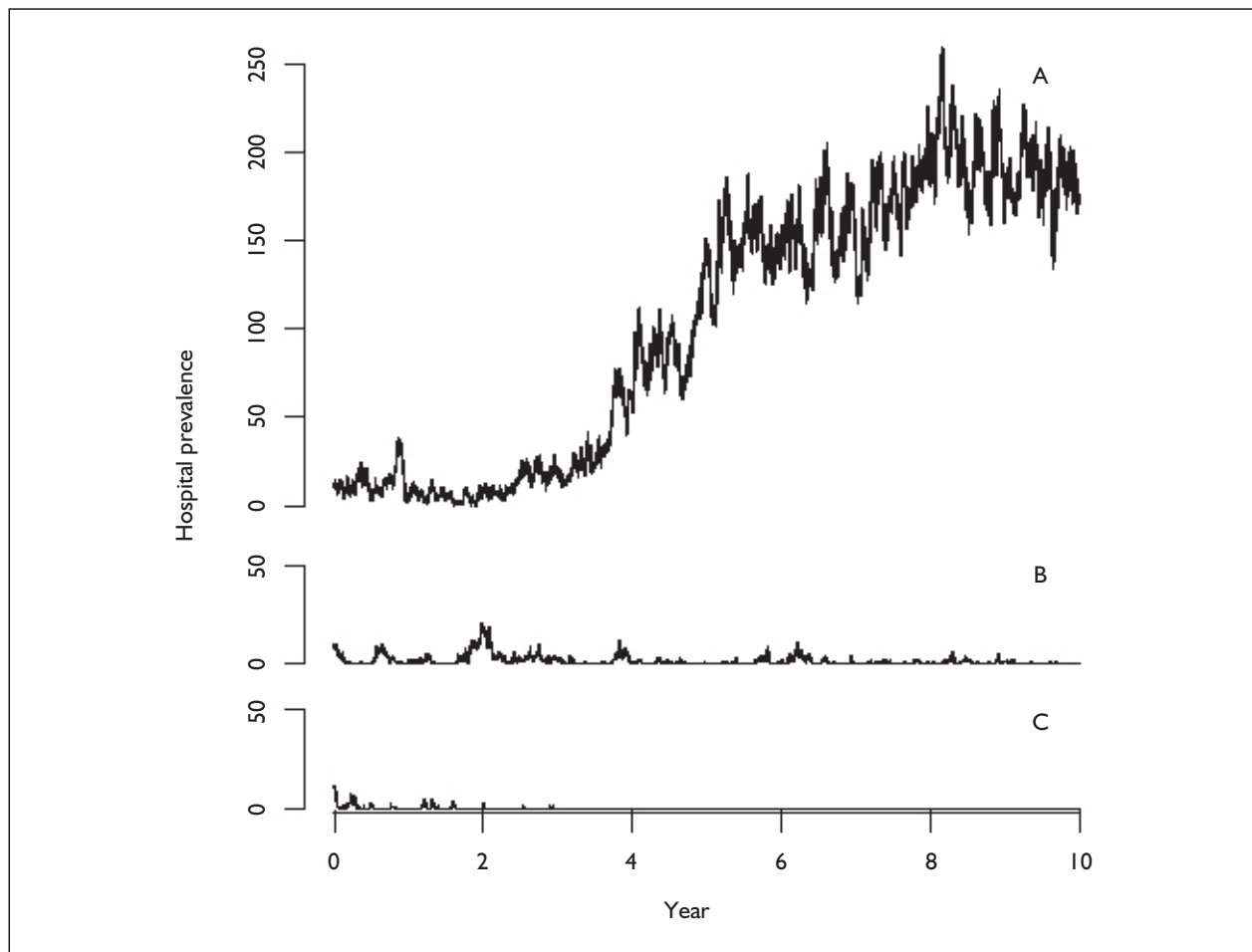

FIGURE 17 Stochastic model with five-bed IW. $R_0 = 1.27$, with isolation rate of $\varphi = 0.04$. All three runs use the same parameters and starting conditions (10 colonised patients).

the random seed used in the computer's random number generator changed.

In run A, the IW clearly fails to control the outbreak, and the capacity of the IW is exceeded. This results in a rapid increase in the number of cases and the establishment of a stable high endemic level. This behaviour is not possible for these parameters in the deterministic model, where the high endemic level would be attained if the IW were introduced later, but not if it was present from the start. In the stochastic system, random fluctuations mean that the system has some probability of jumping to the higher stable level. However, this behaviour only occurs when the barrier between the low and high endemic states is small. Runs B and C illustrate outcomes where successful control is achieved over a 10-year period. In B, however, the organism is able to persist at a low level over the entire period owing to reintroductions and sporadic self-limiting clusters which generate enough new cases to maintain the cycle of reintroduction. In such a

situation, there still remains a chance that a large epidemic as seen in run A will occur. Run C shows a third type of behaviour: rapid fadeout of the organism. In this case no new cases are seen in the hospital after 3 years, although before that time the hospital experiences a series of small self-limiting clusters.

Finally, *Figure 18* shows the effect of introducing an IW in a hospital with endemic MRSA. As was seen in *Figure 12*, the effect is always to reduce the endemic level, though the final level may either be lowered, or eliminated completely if the ward is large enough. Elimination can occur even after a sustained period where the IW's capacity is exceeded but may take several years.

Isolation model with economics

Economic assessments of the isolation policies described above were made. The costs of the resources used for MRSA cases are related to

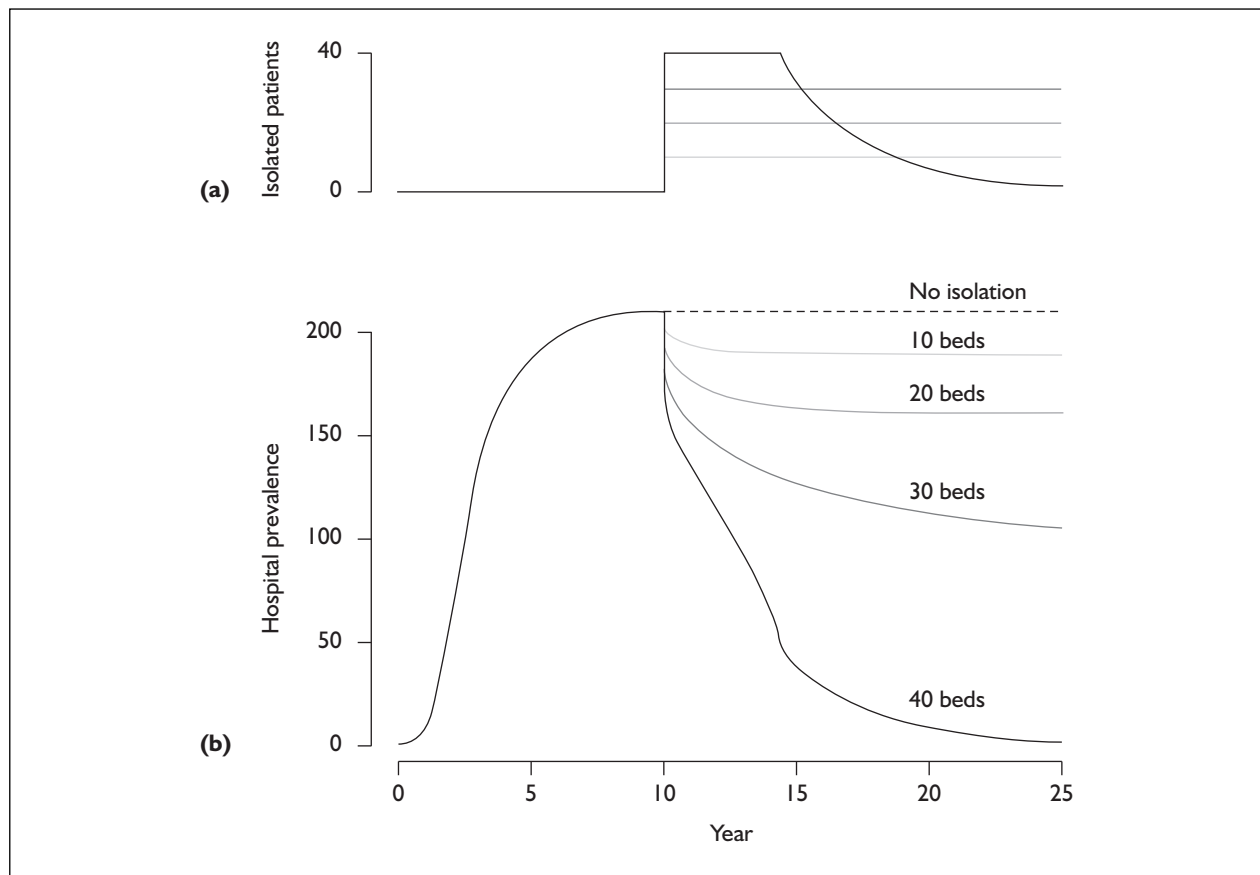

FIGURE 18 Effect of introducing the IW in a setting with a high endemic level of MRSA. All realisations start with one hospital and one community case, and the IW is introduced after 10 years. $\varphi = 0.04$, $R_0 = 1.27$ in all cases.

infection rather than colonisation. It was therefore necessary to modify the above model to distinguish between MRSA-colonised and MRSA-infected patients. Costs of MRSA to organisations other than the hospital and costs to patients are not included; neither are values that individuals would place on avoidance of MRSA. These might have been estimated using 'willingness to pay' approaches. No health status measures are included in this simple model. These could be usefully included in subsequent studies.

Model assumptions

The revised model is identical with the one previously described except in the following respects:

- When acquiring MRSA, patients are assumed to become infected with probability p_I , and to become colonised with probability $(1 - p_I)$.
- Patients who are infected are assumed to have an additional LOS.
- Patients with infections are assumed to undergo treatment and to be discharged only when cleared of the organism.

In this model, all costs attributable to MRSA cases arise due to (i) increased LOS attributable to MRSA infection and (ii) treatment costs for MRSA infections. Additional costs resulting from control programmes are due to (i) cost of provision of isolation facilities with associated overheads and staffing costs (assumed to be unaffected by whether or not isolation beds were occupied) and (ii) costs of screening patients and processing of isolates.

In constructing the model we did not explicitly consider progression from infection to colonisation, or from colonisation to infection, nor did we account for patients who were both colonised and infected. We assumed no difference in infectivity between patients who were infected and colonised.

Data sources

Data on resources used and costs quoted in the papers containing economic data found by the systematic review were from disparate places at different time periods. In addition, papers ranged widely in the comprehensiveness of costs quoted and in the methods used to calculate them. It was

TABLE 5 Costs and additional parameters used in the economic model

Parameter or cost component	Default values (and range)	Source
Cost per unisolated bed day	£332	Royal Free Hampstead NHS Trust
Additional costs per isolated bed day	£9 (range: £4.50–18)	Royal Free Hampstead NHS Trust
Cost per patient screened for MRSA NHS Trust	£6	Royal Free Hampstead NHS Trust
Antibiotic therapy for treating MRSA infection + pathology testing costs	£483	Royal Free Hampstead NHS Trust
Additional LOS attributable to MRSA infection	11 days (range: 6–20 days)	See text
Proportion of patients acquiring MRSA who become infected (p_i)	30% (range: 10–50%)	Larger studies in systematic review had values of ~20–40%
Mean time to detection of MRSA infection	3 days	See text

therefore considered that it would be more useful to estimate the cost components used in the model from a common source using up-to-date costs. Data from the Royal Free Hampstead NHS Trust for the year 2000–1 were used. To aid other researchers who might want to adopt the model, we have reported the cost vectors used in this study in detail. *Table 5* presents the derived costs used in the model. These could be adapted by using data from other settings.

The average cost of a bed day in 2000–1 is quoted for all cases (general surgery, general medicine, elderly care and intensive care). The costs are full costs that include capital, overheads, staff and other non-staff costs. Full-cost pricing was justified because the resources were fully used and the cost of an additional bed day used for an MRSA case absorbs resources that would otherwise have been fully employed caring for another patient. Hence we assumed that beds outside the IW occupied by MRSA-infected patients would have been used by other patients for each day of stay over the mean LOS for other patients. In contrast, we assumed costs associated with the isolation ward to be incurred whether or not those beds were occupied.

The costing of an IW is difficult as many different forms of providing these facilities exist, varying from building new ‘green field’ extensions to adaptations within existing hospitals. The Royal Free Hampstead NHS Trust had recently had a substantial programme to adapt a ward to full isolation standards to accommodate infectious disease services from the infectious disease hospital at Coppett’s Wood. The unit consists of 18 isolation bed rooms, one high-security room and an adjacent laboratory and four beds in two lower grade isolation rooms. This cost £850,000.

These costs were weighted to take into account the increased cost for the high-dependency unit, the lower costs of the recovery room and the cost of the laboratory. For the purposes of this study, estimates were derived for the costs of a single bed in an IW. Costs of screening, testing swabs and treatment of infections were derived from the testing and screening regimes adopted in the Royal Free Hampstead NHS Trust. These costs included materials and staff time (~75% of the total costs).

Table 5 summarises the costs and additional parameters used in the model. Costs arising due to patients acquiring MRSA infections were divided into two components: the cost of clearance therapy and the cost associated with the additional LOS attributable to the infection. The extra LOS in the absence of isolation was taken as the difference between the mean LOS of infected and uninfected patients. When there was an isolation policy in operation, stays were not costed when patients were isolated, as these costs had already been accounted for (in the assumption that the costs were incurred whether or not the isolation beds were occupied). For infected unisolated patients the additional LOS was taken as the difference between (i) the mean duration of infected patients in the hospital outside the isolation areas and (ii) the mean duration that would have occurred if infected patients had the same discharge rate as non-infected patients. There are no reliable data on the additional LOS attributable to MRSA infection. We therefore considered a wide range for this parameter, with default value (11 days) based on expert opinion. There are no data on the delay from an infection first occurring to the subsequent detection of MRSA. However culturing and identification of

the organism using standard methods takes 2–3 days, and under normal circumstances there is likely to be only a short delay between the time at which bacteria first multiply at an infection site and the time at which the first swab is taken. Consequently, we assumed the total delay to be 3 days on average.

The proportion of patients acquiring MRSA who become infected may be expected to vary with the virulence of the MRSA strain and with the vulnerability of the patient population. Amongst the studies in the preceding review that were based in whole hospitals (rather than specific units) and that distinguished between colonisation and infection, the proportion of MRSA patients infected ranged from about 7%¹⁰³ to 67%.⁹⁹ More typically (and in the larger studies) values between about 20%⁸⁸ and 40%^{87,98} were observed.

All such estimates may underestimate the true incidence of colonisation as uninfected carriers will be detected only if screened. Consequently, we consider a wide range of values for this parameter, but take as a default a figure of 30%.

Scenarios

We considered the costs associated with four different isolation policies:

1. No isolation

Ten-year costs were evaluated over a range of additional lengths of stay due to infection (~6–20 days), three levels of virulence (10–50% of MRSA acquisitions resulting in infection) and three levels of transmissibility (0.0007–0.00011 transmission per susceptible patient day arising from one source). There was assumed to be one initial MRSA case in each of the four compartments (hospitalised colonised, hospitalised infected, community with high rate of admission, community with low rate of admission).

2. Isolation of infected patients only

Parameters identical with those in scenario 1 were used, except that infected patients were assumed to be isolated in a five-bed isolation ward (capacity permitting). This was introduced at the same time as the first MRSA case. Cost savings compared with scenario 1 were calculated.

3. Isolation of infected and colonised patients, screening contacts of MRSA patients

To model contact screening, we assumed that for each infected patient detected 20 additional patients were screened, at a cost of £6 per screen. Detected colonised and infected patients were

isolated in the IW (provided that there were beds free). Costs savings were evaluated for a range of values for the rate of detection of colonised patients, ϕ_{col} (0–0.05), reflecting the large uncertainty in this parameter. Other parameters were the same as in scenario 1, under the high transmissibility, low virulence situation.

4. Isolation measures introduced into a setting with endemic MRSA

The IW was introduced 15 years after the first MRSA case, when MRSA levels were close to the stable endemic level. Otherwise, this was the same as in scenario 2 under the intermediate transmissibility and intermediate virulence assumptions. Cost savings over 10 years resulting from IWs of between five and 40 beds compared with the no-isolation scenario were calculated.

Results

Scenario 1: no isolation

Figure 19(a) shows the equilibrium prevalences attained in the revised model without any control measures as a function of the additional LOS attributable to an MRSA infection. Figure 19(b) shows the associated total costs over a 10-year period. Clearly, total costs closely follow the endemic level, although in this case the slopes increase slightly with the additional LOS. The results indicate that costs can be expected to be very sensitive to the attributable LOS (increasingly so for higher transmissibilities), and also to the proportion of patients who become infected (the virulence/patient vulnerability).

Scenario 2: isolation of infected cases

Figure 20 indicates the cost savings achieved by introducing a five-bed isolation ward at the beginning of the outbreak, which is assumed to be used for isolating infected patients. In all other respects, the scenarios are identical with those shown in Figure 19.

As a result of this intervention, MRSA is eradicated (i.e. the prevalence after 10 years is zero) in all cases except for the high transmissibility scenario. When such eradication is achieved, costs associated with MRSA infections are negligible, and are due only to those few cases that occur before the MRSA is controlled; almost all the costs can be attributed to the running of the IW. For the high transmissibility case, complete eradication is achieved only for the strain with the highest virulence. For the medium virulence strain, the prevalence after 10 years is very low (<1), and the IW's capacity is never exceeded. Only for the lowest virulence strain do higher endemic levels

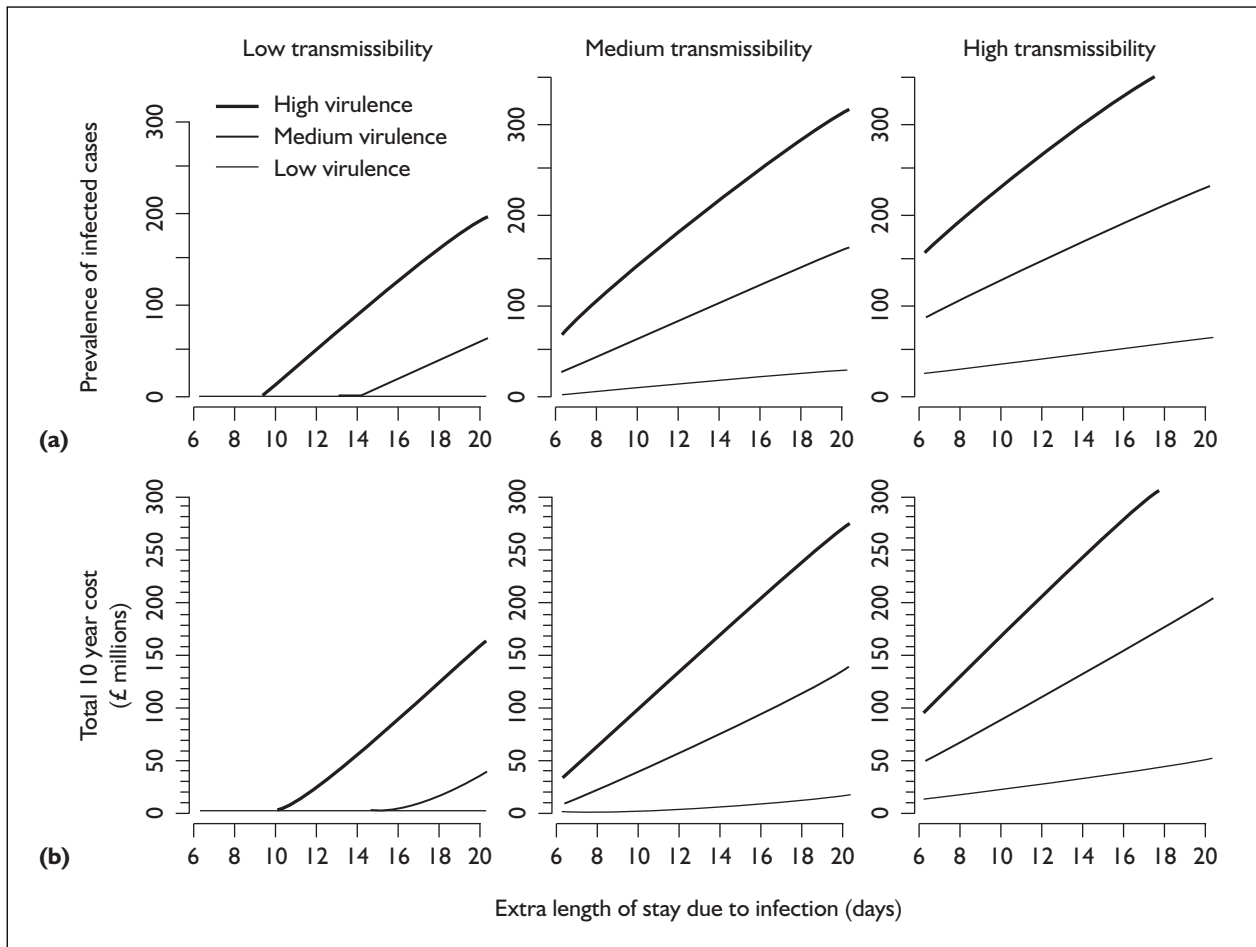

FIGURE 19 Equilibrium prevalence and total cost over 10 years from model with infected and colonised patients without patient isolation, starting from one initial case. Graphs indicate the sensitivity of costs to the additional LOS attributable to an infection, virulence of pathogen (or equivalently the vulnerability of the patient population to infection) and the transmissibility of the organisms. The high, medium and low virulence scenarios assume that 50, 30 and 10% of patients who acquire MRSA have infections, respectively. High, medium and low transmissibility scenarios assumed values for β of 0.00011, 0.00009 and 0.00007, respectively.

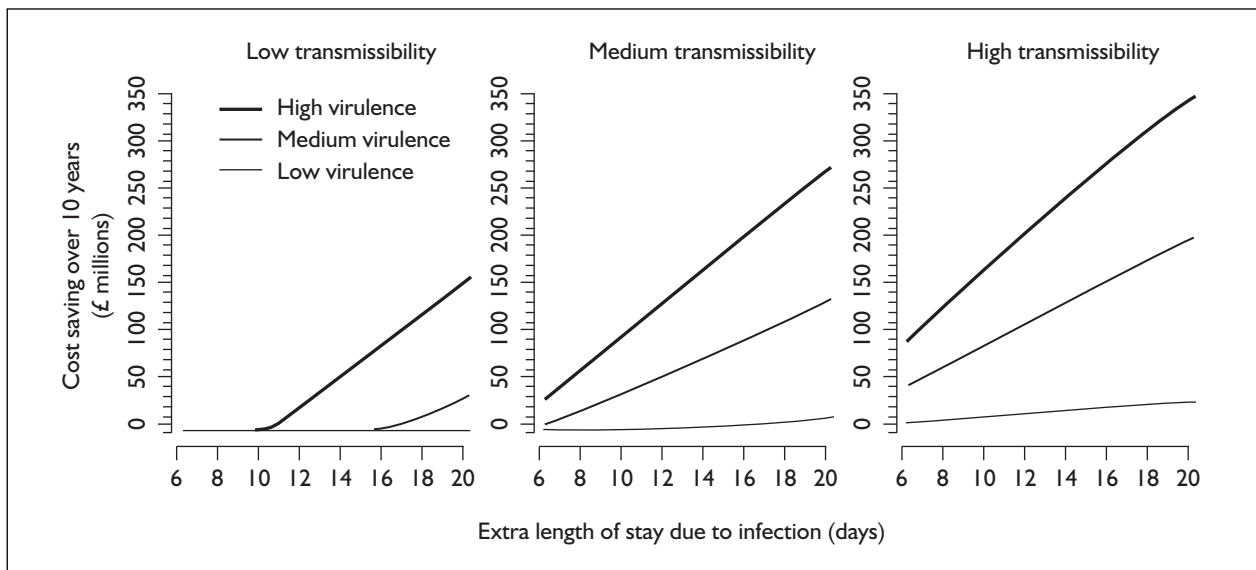

FIGURE 20 Cost savings for the same scenarios as in Figure 19, but now isolating infected patients in a five-bed IW. Cost details are given in the text.

TABLE 6 Costs and cost savings associated with use of an IW for infected MRSA patients over a 10-year period, under the assumption of high transmissibility and low virulence, additional LOS attributable to MRSA infection set to 11 days^a

IW beds	10-year costs excluding IW	10-year IW costs	Total 10-year costs	Cost saving (compared with no isolation)
0	24.4	0	24.4	–
5	8.6	6.2 (6.1, 6.4)	14.8 (14.7, 15.0)	9.6 (9.7, 9.4)
10	3.4	12.4 (12.3, 12.8)	15.8 (15.6, 16.1)	8.6 (8.8, 8.3)
15	0.96	18.7 (18.4, 19.2)	19.6 (19.4, 20.1)	4.8 (5.0, 4.3)
20	0.92	24.9 (24.6, 25.6)	25.8 (25.5, 26.5)	–1.4 (–1.1, –2.1)

^a All costs in £ millions. Figures in parentheses are calculated on the assumption of 50 and 200% capital costs for the IW.

become established, with final prevalences of infected cases ranging from 20 to 53 (and increasing with increasing attributable LOS).

As *Figure 20* shows, although ultimate eradication is not always achieved, the intervention results in substantial cost savings in all situations considered for the high transmissibility strain, ranging from £2.4 million (low virulence, attributable LOS 6.2 days) to £350 million. These savings are due to the large number of cases prevented. For the low and medium transmissibility strains, positive cost savings over 10 years are achieved whenever the IW prevents an endemic level of about 20 infected patients. When these calculations are repeated with the additional cost per IW bed day set to 50% and 200% of the original value (£4.50–18), minimal differences are obtained in the outcomes; lines plotted for these values cannot be distinguished from those in *Figure 19*, indicating that results are insensitive to capital costs.

We also explored the sensitivity of the results to the size of the IW for the high transmissibility/low virulence scenario (the one case where a high endemic level was established despite the five-bed isolation ward). *Table 6* shows cost savings over 10 years as the number of isolation beds was varied between five and 20, under the assumption that an MRSA infection causes an increased LOS of 11 days. *Figure 21* shows the dynamics for these scenarios.

For these scenarios all the policies ultimately fail to prevent endemicity: the steady increase in the number of colonised patients results in an increasing number of infected patients, until the IW's capacity is exceeded. Nonetheless, the use of 5–15-bed isolation wards results in cost savings over this period. The total cost when the 20-bed isolation ward is used, however, just exceeds that when no isolation is attempted, despite the fact

that this policy prevents MRSA from becoming established at a high endemic level. This large cost results from the fact the full costs of the ward are assumed to be incurred even when it is operating below capacity. As is apparent from *Figure 21*, over a longer time period this policy would result in a cost saving compared with the policy of no isolation measures.

Scenario 3: isolation of infected and colonised cases

Table 7 reports cost savings associated with a screening policy, again for the high transmissibility, low virulence parameters. Even the slowest rate of detection of colonised patients leads to control (prevention of an endemic level of MRSA becoming established), and results in substantial cost savings over the 10-year period. In other scenarios (results not shown), it was found that screening policies could increase the prevalence (and hence the costs), if isolated colonised patients occupied beds that could have otherwise been used by infected patients. Since infected patients are assumed to stay longer, the gains from isolating these patients are greater as more secondary cases are prevented. As *Table 7* shows, however, when there is unused IW capacity, a screening policy can be expected to reduce the overall prevalence, and is likely to be cost-effective, as costs associated with screening are very small compared with those due to increased LOS resulting from an infection. Also, in contrast to costs associated with the IW, screening costs do scale with the prevalence, so if there are few cases additional screening costs are very low.

Scenario 4: isolation of infected cases when MRSA is initially endemic

Figure 22 shows the cost savings achieved over 10 years resulting from the introduction of an IW for infected patients in a setting with endemic MRSA. The introduction of the IW can either

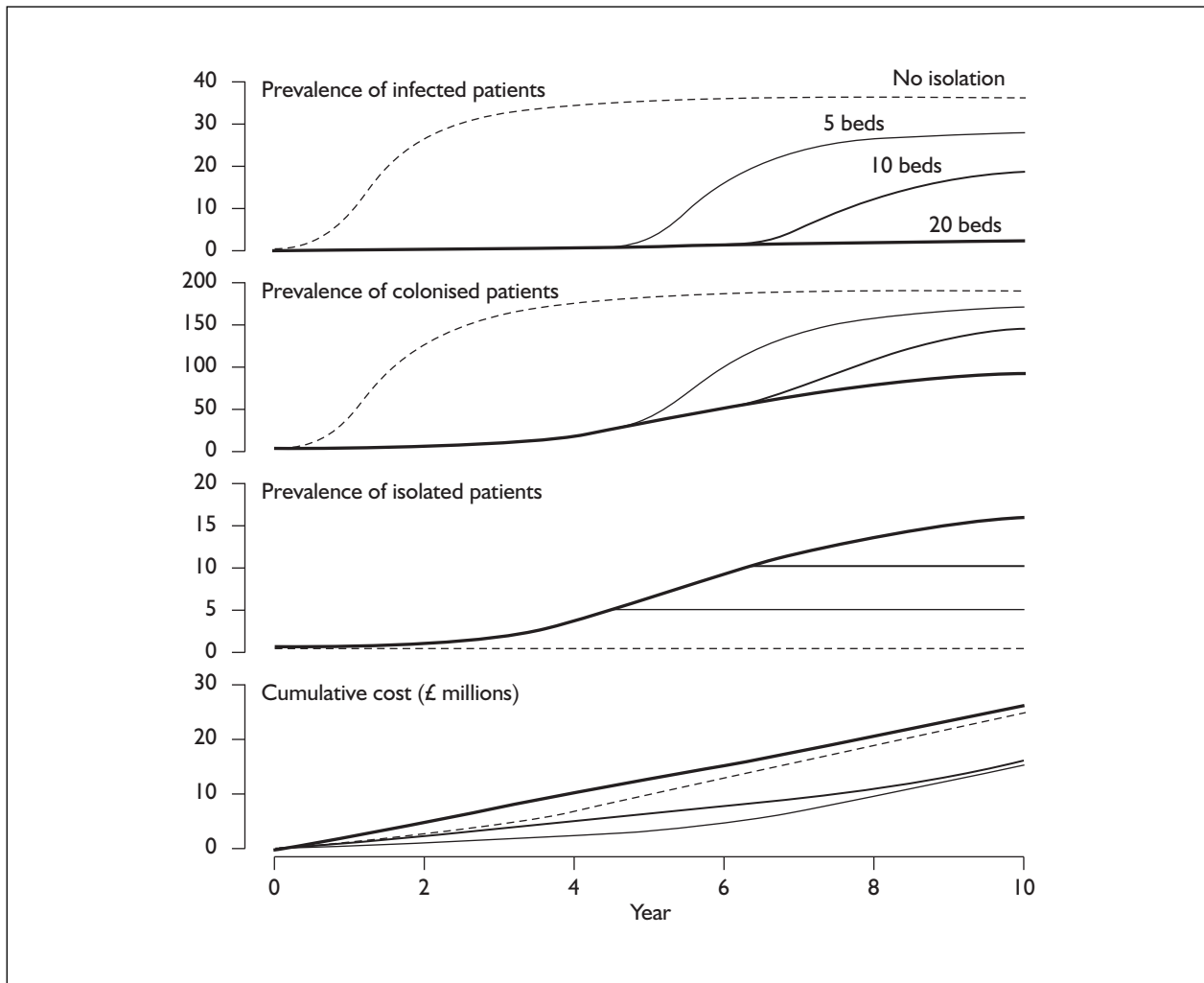

FIGURE 21 Time series for the high transmissibility, low virulence scenario with an additional LOS attributable to MRSA infection of 11 days. Outcomes for no isolation and for IWs of 5, 10 and 20 beds are presented. Cumulative costs are calculated assuming that capital costs associated with the IW are distributed evenly over the 10-year period. Default values for other parameters were used. (μ_{inf} was taken as 0.045, 30% of patients acquiring MRSA were assumed to become infected. The transmission rate was set here to be 8×10^{-5} .)

TABLE 7 Cost savings associated with use of an IW for infected and colonised MRSA patients over a 10-year period, under the assumption of high transmissibility and low virulence^a

IW beds	Mean time to detection of colonised patients (days)	Endemic level of MRSA-infected patients (%)	10-year costs excluding IW	Total 10-year costs including isolation costs	Cost saving (compared with no isolation)
0	(No screening)	37	24.4	24.4	–
5	(No screening)	30	8.6	14.8	9.6
5	20	0	0.001	6.2	18.2
5	50	0	0.005	6.2	18.2
5	100	0	0.06	6.3	18.1

^a All costs in £ millions. Colonised patients were assumed to be detected by screening contacts of MRSA-infected patients (20 contacts per infected case), and the IW was assumed to be introduced at the same time as the first MRSA case. Additional LOS attributable to MRSA infection is set to 11 days.

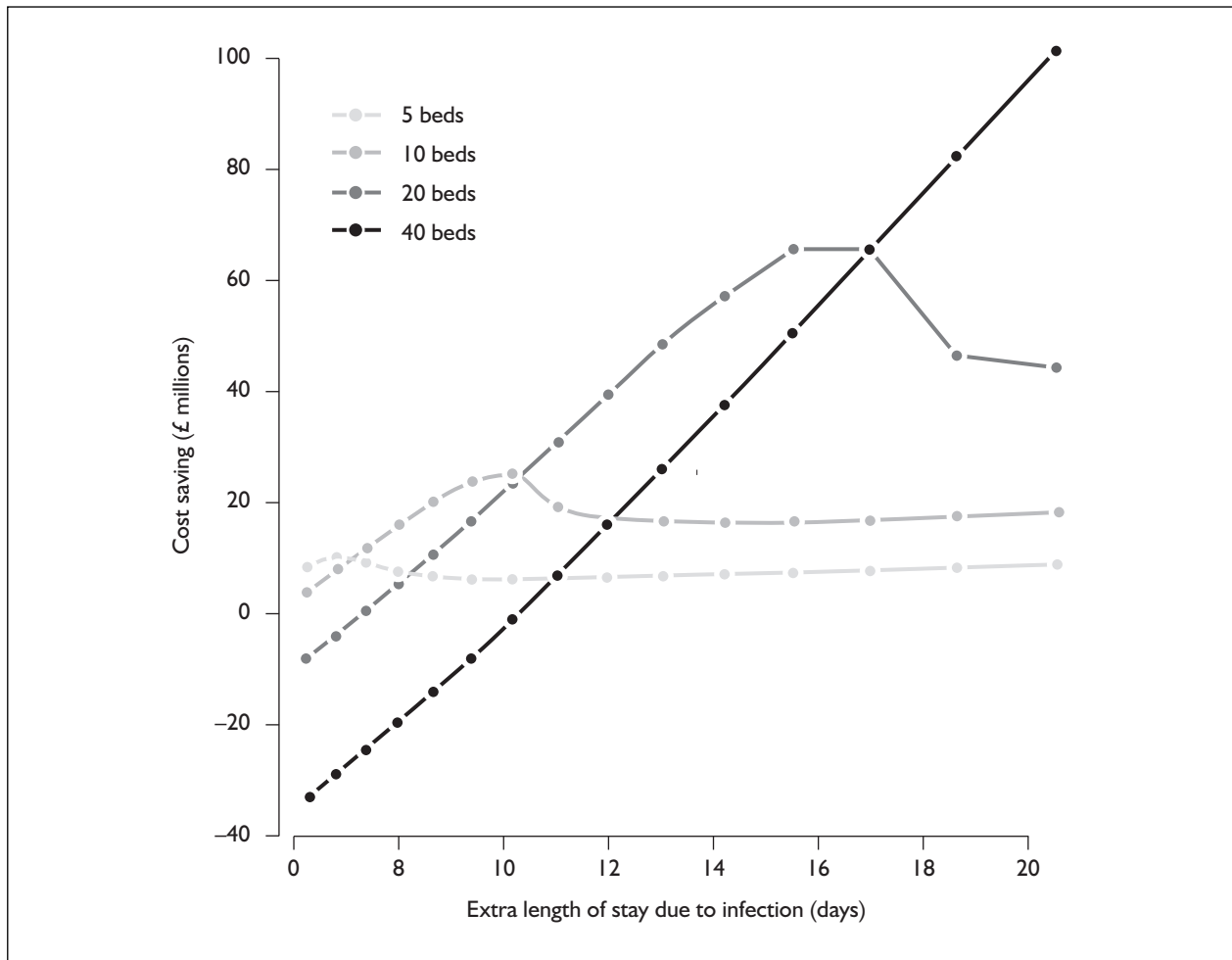

FIGURE 22 Total cost savings over 10 years of policies using IWs introduced to control endemic MRSA compared with no isolation. The intermediate transmissibility, intermediate virulence scenario was assumed, with isolation measures introduced 15 years after the introduction of MRSA.

reduce MRSA levels to a lower stable prevalence, or completely eliminate the organism from the hospital. When the additional LOSs caused by infections are shorter, the smaller IWs are sufficient to eradicate the organism, and these result in the largest cost savings. When these attributable LOSs are longer, and consequently the endemic prevalence without isolation higher (see *Figure 19*), smaller wards still reduce the endemic prevalence, resulting in cost savings, but only larger IWs are able to reduce prevalence to minimal levels, resulting in the largest cost savings. For example, in a setting where attributable LOS is about 8 days and the prevalence of infected patients about 40, the largest cost saving is achieved with a 10-bed IW, and large costs would be incurred by the use of a 40-bed ward owing to the unused capacity. Cost savings still result, however, from smaller IWs in this setting. *Figure 23* illustrates the underlying dynamics, showing how the attributable LOS and

the number of IW beds both determine whether ultimate eradication of the organism is achieved.

Discussion

Previous work

A number of models of the transmission of nosocomial pathogens have been presented elsewhere.^{51,69,121,123,124} Much of this work has been concerned with the interactions between antibiotic-sensitive and antibiotic-resistant strains and the effects of antibiotic use on these interactions. Many have also looked at how staff handwashing patterns may be expected to affect transmission patterns.

In common with other epidemic models, these studies have emphasised the importance of threshold effects in determining the ability of a pathogen to persist in a population (showing that

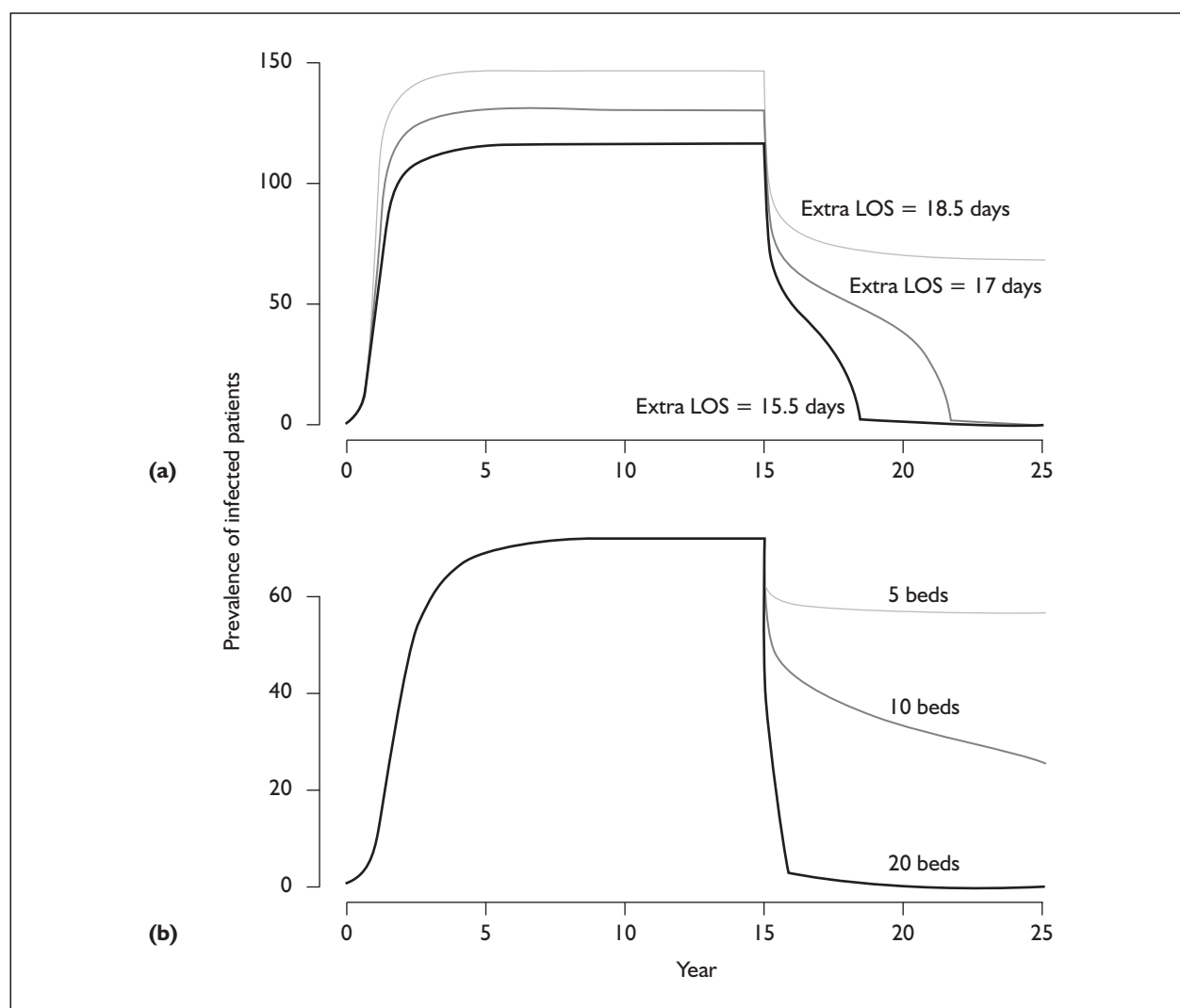

FIGURE 23 Prevalences from sample simulation from scenarios in Figure 22. (a) 20-bed IW introduced after 15 years for three different values of additional LOS due to infection. (b) IW introduced after 15 years for three different IW sizes, when additional LOS due to infection is 11 days.

persistence should not occur below a certain level of antibiotic use, or above a certain handwashing frequency). Ward-based models including stochastic components have also demonstrated that chance fluctuations can be a dominant factor in the observed incidence. Patterns of inter-hospital spread have also been modelled (ignoring the intra-hospital dynamics), with models used to forecast the course of an outbreak of resistant organisms in terms of numbers of affected hospitals at a national level.¹²²

The modelling framework presented here has ignored factors such as antibiotic use and carer behaviour. Although likely to be important, these measures are not directly relevant to the questions being addressed in this report. Instead, we have only considered control measures based on patient

isolation. In contrast to other models, we have investigated the dynamics of the system at the hospital and community level, explicitly considering patterns of readmission of discharged patients. This decision was based on a recognition that previous models were unable to account for observed changes in numbers of patients colonised on admission and the gradually increasing prevalences reported in studies in the systematic review. Such increasing prevalences are important as they may ultimately lead to control failure. Indeed, recent revisions of national MRSA control guidelines were prompted by an increasing prevalence of MRSA within hospitals that had made the older recommendations impractical.⁴

In Chapter 2, we used a single-ward model that did not explicitly consider readmission patterns to

study bias and statistical validity in the analysis of observational data. In this chapter, we have used models that simultaneously track hospital and community cases to study the impact of detection and isolation on transmission, and the cost-effectiveness of such interventions.

Outcomes

The initial model without isolation measures showed that observed patterns of patient readmission and durations of MRSA carriage in the community were able to account for long-term trends and changes in numbers colonised on admission.

For the lower transmissibility scenario ($R_0 = 1.1$), this produced a pattern of spread and hospital and community prevalences similar to those currently seen in hospitals in the UK. For this scenario, an equilibrium community prevalence of about 3000 was established, representing almost 1.7% of the community population (in this model, the community population size is defined by the readmission parameters and hospital size; estimates of these from Royal Free Hospital data gave a value of $\sim 180,000$, which is close to the known population served by the hospital). This level was attained assuming no community transmission. Community prevalence studies in the UK have found similar values (the most recent reporting 1.5% of people in the community to be nasal carriers¹³²). These observations add weight to the hypothesis that community transmission of the most prevalent UK strains is not a major cause of spread.⁶⁰

The scenarios with the higher R_0 values in *Figures 9* and *10* show what could plausibly be expected to happen were more transmissible strains to emerge, or changing conditions in UK hospitals to result in increases in the transmissibility of current strains.

Stochastic effects were also shown to be important even in the relatively large hospital populations considered here (1000 patients). Large fluctuations occur purely owing to chance, and illustrate the difficulties of trying to make inferences from data over shorter time periods, even using whole-hospital data. For example, the increasing trend in *Figure 10* would often not be apparent over periods as long as 1–2 years. Consequently, studies reporting surveillance of MRSA over time (even at the level of a whole hospital) are vulnerable to reporting bias and regression to the mean effects, even if they cover periods as long as 2 years, depending on the transmissibility of MRSA in the setting. The best way to remove this potential bias

is for continuous, routine surveillance and publication rather than ‘one-off’ studies, especially if such studies are triggered by unusual increases or decreases. Such long time series would also help us to assess where individual hospitals are on the epidemic curve and therefore how much further MRSA levels might be expected to increase in the absence of additional control measures.

One further result of some interest is that the ratio of secondary (newly acquired) to primary (imported) cases decreases over time as prevalence increases, eventually reaching a value independent of the transmission rate. It can be shown algebraically that this result holds in general, and is not dependent on the specific details of patient readmission patterns. Initially, however, the ratio is highly dependent on the transmission rate and in the early stages of an epidemic could provide valuable information about the transmissibility and therefore the expected course of the epidemic.

Model with isolation

The use of an IW for detected MRSA patients was shown to reduce the prevalence and in some cases to be capable of eradicating the organism completely.

Increasing the IW size was shown to decrease the prevalence provided that the detection rate was not the limiting factor (i.e. the smaller IW would have been full). Similarly, provided that the IW is not full, increasing the detection rate should reduce prevalence. The ultimate stable level reached (and whether or not eradication can be achieved) was shown in many cases to depend critically on the timing of opening, with IWs opened early in an outbreak far more likely to reduce prevalence to a minimal level. Thus IWs are most effective when used from the beginning of an outbreak when prevalences are low. However, if sufficiently sized and with sufficient detection rates, they should also be capable of leading to the eradication of an endemic organism by reducing the number of secondary cases from each primary case to a sufficiently low level. It was shown, however, that in many cases such an elimination would be expected to occur only over periods of many years. As a result of stochastic fluctuations, detecting such reductions would require long time series data (see Chapter 2). Finally, we also found that for small IWs stochastic fluctuations in MRSA numbers could sometimes lead to control failure when local capacity was overwhelmed. Together, these various considerations provide plausible

explanations for the conflicting evidence from the systematic review of the effectiveness of IWs in controlling MRSA. A more detailed assessment of the key factors involved in particular studies in the review would require additional data, not available in those studies.

Although the model explicitly considered an IW, the qualitative results could also apply to other forms of isolation if these are effective at reducing transmission. Such qualitative aspects will apply whenever the effectiveness of the isolation measure is limited as the prevalence increases (i.e. the control measure does not scale with the size of the problem). This clearly applies to single-room isolation, as only a fixed number of single-room beds will be available. It will also apply to NC if the ability to carry out this policy is limited by staff availability, since this policy requires higher staff to patient ratios. Indeed, a number of reports of NC have cited staff shortages as the reason why the policy had to be abandoned.⁷⁹ Staff shortages may also be one reason why IWs can be difficult to operate in practice under current conditions in the UK.

Economic analysis

Economic analysis showed that isolation policies can result in cost savings over 10 years both when they prevent endemic levels from becoming established, and when they act to reduce the endemic prevalence to lower levels. Only when there are extended periods with a large number of unused isolation beds, or when only low prevalences of infection would have been reached without control measures, were the policies found not to be cost-effective. These results were found to hold over a wide range of transmissibilities and virulence levels (or equivalently, patient vulnerabilities), and to be insensitive to capital costs.

The analysis showed that by far the largest contribution to costs associated with MRSA are likely to be due to the extra LOS caused by infections. However, very little is known about this parameter. Although there are numerous studies which compare LOSs of MRSA-infected individuals with those of other patients, there are two important reasons why these data do not allow assessments of the increase attributable to MRSA infection. First, those patients who become infected with MRSA are often the most ill and likely to have many factors that predispose them both to longer LOSs and to acquiring MRSA. Second, the longer patients stay, the more likely they are to acquire MRSA. Consequently, we can

do little more than consider a range of plausible values until research using more reliable methods of attribution has been conducted. Naïve assessments of increases in LOS caused by MRSA often simply take the difference between the lengths of stay of those acquiring and not acquiring the organism. However, patients with shorter stays clearly have less chance of acquiring the organism, simply by virtue of their reduced exposure. This fact alone is able to account for surprisingly large differences in reported stays between the two groups.

Given these large uncertainties in the most important parameters for economic assessments, it was felt that a more detailed approach to the economic modelling could not be justified, and a number of simplifying assumptions were made. The costs were not discounted, implying that the savings that follow from the use of the IW may be overestimated slightly (although results show remarkable insensitivity to capital costs). However, the assumption that full costs are incurred regardless of how many of the isolation beds are unoccupied would lead to overestimates of the costs of running an isolation facility, as lower staffing levels would be appropriate during periods with lower bed occupancy in these units. As a result, an isolation policy that reduces the staffing level on an IW when there is less than 100% bed occupancy can be expected to be a more cost-effective solution than the scenarios considered here. On the other hand, we have not included opportunity costs of empty beds on IWs, which might be used for other purposes. There were no local data or information in the literature that could help assess these.

Limitations

The principal limitations of these models, just as any others, is that they are only models, and reduce complexity to a minimum. The major reduction has been to ignore heterogeneities occurring within the hospital. We discuss some of these assumptions below.

The models presented here assumed homogeneous patient and carer populations. In practice, patient heterogeneity may be important: individuals who are most vulnerable to infection may also be likely to have LOSs and higher readmission rates and require more staff contact, resulting in more transmission to other patients. Such a group of high-risk patients can act as a 'core group' of infection within a hospital. Similarly, groups of staff that have high rates of contact with different patients throughout the

hospital can have a disproportionate effect on transmission. Large differences between individual wards are also likely, with ICUs often implicated as sites of particularly high transmission, and the ward-based population structure of hospitals can also be important if there is little inter-ward transmission. These heterogeneities generally increase the propensity of MRSA to cause an epidemic, and make the infection more persistent, although they may also reduce the overall prevalence. Targeting of core groups for special attention should, theoretically, increase the cost-effectiveness of any control programme.

We have not addressed any of these issues, partly because of a lack of specific, reliable data. However, the results that we present are broadly compatible with observations, and the importance of these heterogeneities is debatable and largely based on theoretical arguments. Although it is possible to construct ever-more complex models, there is little reason to expect this approach to result in ever-more reliable conclusions if such complexity means that additional uncertainties have to be incorporated.

Instead, the priority here has been to gain a theoretical understanding of the dynamics using simple models that can be readily understood. Models such as these allow predictions about patterns of behaviour and relationships between

outcome measures, but should not be considered as reliable tools for forecasting. However, wherever possible, we have used realistic parameters estimated either from the literature or, when this was not possible, from our own data.

Future work

As with many infections, there is surprisingly little good information and few data to allow estimation of basic parameters. For example, we found only two studies that provided good data on the duration of carriage of MRSA, and only one study in the review allowed an estimate of the transmission rate from a colonised patient (and this came from a neonatal unit, which is unlikely to be representative of other hospital wards).⁹⁵ Crucially, there are no good data on how long MRSA infection prolongs stay and influences hospital costs.

We suggest that future work should concentrate on the collection of more reliable data and on the estimation of key parameters, including economic parameters. Such data should also allow existing models to be assessed and also compared with models making different assumptions. The resulting calibrated models should then serve as more reliable tools for forecasting, exploring the likely effects of interventions, performing economic assessments and designing cost-effective interventions.

Chapter 6

Discussion

Methodological aspects of the review

In contrast to previous narrative reviews of MRSA control policies, this study was based on a systematic and extensive search of the literature and a systematic appraisal of the quality of the evidence. At least two reviewers were used for each step of the review, working either independently (data extractions, full-article appraisals and final accept/reject decisions) or together (abstract appraisal). Although the duplication of effort added a substantial amount of time to the review process, we felt that it was highly valuable. Often it was not clear what interventions were made or what outcomes were being reported. In many cases, such as the complexity or lack of clarity of study description or design that initial assessments diverged between reviewers and important details were missed. In all cases, the differences could be resolved by discussion and agreements reached. It was felt that without this process many important aspects of the research would have been overlooked or misclassified.

Search strategy

The search strategy was developed by library staff with training in systematic review methodology (RL) together with team members with detailed knowledge of MRSA control (SPS, CK).¹³³ It was highly inclusive and without language restrictions. Handsearching confirmed the sensitivity of the search.

Although our search strategy initially included the grey literature, we decided early in the review not to include any unpublished studies or research described in conference abstracts. While such a search may reduce the vulnerability of systematic reviews of experimental research to publication bias, the potential benefit of such an extensive search is thought to be limited in observational studies.⁷³ Considerable additional resources would also have been required.

There were five studies based on survey data reporting isolation measures at different hospitals and MRSA outcome data.^{109,134–137} Unfortunately, none of these papers, except that by Esveld and colleagues,¹⁰⁹ related the two. Because this type of

design should be free of many of the biases associated with the more common retrospective ITS, we wrote to authors requesting data that enabled control measures and outcomes to be related. It was felt, however, that the information we received was insufficient for a full assessment, and that the required reanalysis would have been beyond the scope of the review.

Inclusion criteria

Our initial abstract selection criteria were very broad, and included all studies describing attempts to control MRSA in hospital settings. The initial full-article acceptance criteria were designed to accept all articles that described control of MRSA using any isolation policy, without restriction on study design, provided that studies were reported in sufficient detail with relevant outcomes. However, the very large number of studies accepted after the initial full-article appraisal necessitated modifications to these criteria.

The revised criteria were designed to select all studies that included an IW or NC, as these interventions were considered to have the strongest theoretical rationale (face validity), were relevant to current NHS practice and, if shown to be effective, would have the greatest implications for resource allocation and organisation of services. Prospective studies and other studies where planned comparisons were made were also given priority, whatever the intervention (provided that an isolation policy was clearly described), as these studies may be expected to be less vulnerable to biases than retrospective outbreak reports. We kept to a wide definition of prospective (see Glossary) in order to maximise the scope of the review. The very large volume of non-English language papers meant that we were forced to impose slightly more stringent selection criteria for these papers.

Even with these modifications, our inclusion criteria were very broad. Notably, we did not restrict our attention to comparative studies. Furthermore, a number of the included studies, although comparative, lacked a comparator in terms of populations or periods with different isolation or screening policies. This enabled us to

study the interactions of existing isolation policies with additional measures, such as hand-hygiene education or antibiotic restriction.

Article assessments and data extractions

We chose not to use any formal scoring system for quality assessments, as results obtained using such systems have been shown to be highly inconsistent.¹³⁸ It was felt that any such formal scoring systems or classification would lend a misplaced concreteness to our outcomes. Instead, we systematically documented component threats to validity during and after the data-extraction process, considering each threat to validity separately.

Summarising the evidence

Summaries of the evidence provided by each study were descriptive rather than quantitative, as in all but two studies the authors presented clearly inappropriate analyses of outcome data. Formal meta-analysis of results was inappropriate owing to the very large diversity of settings, interventions and outcome measures.

We chose not to reanalyse data using more appropriate statistical methods. In most cases insufficient data were reported to allow further analysis. In a few cases data were detailed enough to permit reanalysis (using, for example, time-to-event models), but these studies tended to be short, retrospective, outbreak reports, and it was felt that other threats to validity in such studies were so large that little would be gained.

In the report by Duckworth and colleagues,⁸⁹ data reanalysis would seem particularly appropriate. Although this study described an extensive time series, with adequate time points for the application of time series methods, the data were in the form of counts (as in much of the rest of the literature). Standard time series methods, such as ARIMA models (recommended by the Cochrane EPOC group⁷³ for the analysis of long time series data) are only appropriate for continuous outcomes, and count data only when the numbers are large enough that a continuous approximation is justified. For the data in the study by Duckworth and colleagues,⁸⁹ this condition is clearly not met as the weekly counts are too small and the assumptions of ARIMA models violated. Although autoregressive models for count data have been developed,¹³⁹ this remains an active research area, and the most promising methods have not been implemented in major statistical computer packages. There is currently a need for a formal

assessment of different approaches to analysing such time series count data as typically arise from hospital epidemics.

Instead of reporting *p*-values or CIs, we therefore summarised the most important MRSA-related outcomes. The strength of evidence from each study was characterised on a case-by-case basis. This characterisation of the evidence should not be considered as a formal scale, but represents a qualitative assessment of the strength of the evidence after consideration of study size, treatment effects and assessments of the plausibility of major threats to the validity of the conclusions. Since the plausibility of many of the threats to validity is itself dependent on other observational research subject to similar limitations, such assessments necessarily have a subjective element.

Quality of included studies

The quality of the studies did not generally meet the standards expected of planned research. All study designs used were vulnerable to a number of potentially important confounders, yet many of these were not recorded or, if recorded, were not adjusted for in any analysis. Furthermore, very few studies described any measures taken to prevent bias. In particular, in the majority of studies there was no evidence to suggest that decisions to report data were made independently of the outcomes themselves. Such reports must therefore be considered to represent unplanned comparisons, and large reporting bias may be expected. Many apparently 'prospective' studies considered interventions made in response to high MRSA levels, and compared subsequent MRSA levels only with those that prompted the intervention. Such studies will be vulnerable to regression to the mean artefacts. Reporting of data was variable, but few studies presented adequate time series for assessing interventions, and few authors distinguished between patients who had been colonised on admission and newly acquired cases, thus making interpretation of outcomes difficult. Point prevalence data were rarely reported, and it was usually impossible to make any adjustment for the varying size of a setting's MRSA reservoir in different phases of a study. Most statistical analyses reported by authors used inappropriate methods that are likely to produce highly misleading results. There was little comprehensive and consistent information on economic costs. Economic data that were presented related to different interventions at different sites in

different countries over an extended time period. This was not suitable for conducting a meta-analysis of the cost-effectiveness of the interventions. There was also very little attempt to consider the opportunity costs attributable to preventing MRSA.

Assessment of control measures

Nearly all studies used combinations of measures in an attempt to reduce MRSA transmission, the commonest interventions being screening, topical eradication and an isolation policy (others included handwashing education, antibiotic policies and feedback of surveillance data). It was not possible to assess the relative contribution of the different elements of such control policies.

It was impossible to draw any conclusions about the effect of patient isolation in combination with other control measures from about one-third of the accepted studies. Most of the remainder reported evidence consistent with either control or reduction of MRSA transmission. In about half of these we considered the evidence to be very weak, owing to limitations of study designs employed and/or limitations of reported data.

Of the 13 studies presenting better evidence we considered that in six there were clear plausible alternative explanations (unrelated to interventions) for changes in MRSA levels attributed to isolation policies.^{79,81,82,83,95,109} We found six studies where we considered that the quality of data reporting and study designs, the treatment of potential confounders, and the magnitude of apparent treatment effects were together sufficient to rule out the most plausible alternative explanations for reported changes in MRSA levels.^{76,84,89,91,92,118} We therefore considered these studies to represent the strongest evidence for assessing the effect of control measures that include an isolation policy. Although even the studies providing the stronger evidence often failed to record data on potentially important confounders, such studies provide testable hypotheses that could be assessed in future planned studies.

Taking each category of isolation in turn, the evidence from these 13 studies can be summarised as follows.

Isolation wards

The strongest evidence was considered to come from three studies. One, by Farrington and colleagues,⁹¹

showed that MRSA could be controlled for many years with a control policy based on an IW, screening, eradication and ward closures. Control failed when a change in strain and/or an increase in the number of patients colonised on admission presented an overwhelming challenge to the institution. A second study, by Faoagali and colleagues,⁷⁶ described the failure of an IW (in combination with screening, antibiotic restriction and hand-hygiene education) to prevent a huge rise in colonisation and infection. The third, by Duckworth and colleagues,⁸⁹ reported reduction of MRSA infection associated with an IW, together with screening and eradication, although some important potential confounders were not documented. Two other studies, by Selkon and colleagues⁸² and Murray-Leisure and colleagues,⁸³ were considered to present evidence supporting reduction of MRSA by an IW, although plausible alternative explanations existed (changes in antibiotic use, reduction in numbers colonised on admission and a generalised regional decline in MRSA). One other study, by Cox and colleagues,⁸⁸ was considered to present evidence of failure of an IW to control MRSA transmission, although changes in MRSA were smaller and some important potential confounders were not recorded. None of the studies of IWs employed control populations (apart from different study phases for the same setting). In the cases where IWs failed to reduce incidence or prevent endemicity, it is therefore not possible to tell whether they had any effect in delaying the onset of high endemic levels, slowing the rate at which prevalence increased or reducing the ultimate endemic level.

Nurse cohorting

The strongest evidence for the efficacy of NC came from Coello and colleagues' study¹¹⁸ that combined screening and eradication with the use of designated nurses for MRSA patients isolated in single rooms or in cohorts. Two studies^{79,81} were considered to provide evidence of reduction of MRSA but with plausible alternative explanations such as a variation in patient bed days, regression to mean and changing LOS.

Other isolation policies

The strongest evidence for the efficacy of these was considered to come from two studies that used single-room isolation. In one the control policy (as described in several reports^{80,92,140} also included screening, topical eradication therapy, automated alerts for readmitted MRSA patients, together with a hand-hygiene programme (including audit, feedback and education). In the other study, the

control policy also included patient cohorting, screening, feedback of surveillance data and hand-hygiene education.⁸⁴

Two studies analysed outcomes in terms of the reduction in transmission per source associated with isolation. That by Jernigan and colleagues⁹⁵ was considered to provide evidence that immediate contact isolation (gowns, gloves and masks) reduced transmission from infants with MRSA, although there was potential for large bias in outcome assessment. The study by Esveld and colleagues¹⁰⁹ was considered to provide evidence that prompt isolation (which included the use of single negative-pressure rooms) of index MRSA cases reduced subsequent transmission in the general hospital population. However, plausible alternative explanations and potential biases existed.

Mathematical modelling and economic evaluation

The mathematical model of MRSA transmission in Chapter 5 assumed that all transmission occurred within the hospital, but also explicitly modelled the community prevalence. This work demonstrated the importance of considering long-term trends in the evaluation of interventions, and of explicitly considering changes in prevalence and the proportion of patients colonised on admission. A stochastic version of the model showed that random fluctuations can be expected to be large even in whole-hospital populations. This suggests that threats to validity that depend on such variation (i.e. reporting bias and regression to the mean) can be expected to be important even for data from whole-hospital populations over periods as long as 2 years unless adequate measures are taken to guard against them.

The model was used to examine the effect of an isolation measure, such as an IW, that was assumed to prevent transmission from isolated patients, but to be capable of only isolating a fixed number of patients at one time. It was shown that, depending on the values of key parameter values (such as transmissibility of the organism and rate of detection of colonised patients), such a control policy was capable of preventing MRSA becoming endemic, provided that (i) the IW had sufficient capacity, (ii) the IW was opened sufficiently early in an outbreak (when isolation capacity was a limiting factor) and (iii) patients could be detected and isolated fast enough. The model showed that

such a policy could ultimately fail to control MRSA, even though control was achieved over a period of several years. This failure resulted from a gradual increase in patients admitted with MRSA, leading to an eventual saturation of isolation facilities. Nonetheless, even when such control failure occurred, the policy reduced the rate at which the prevalence increased, delayed the period until higher endemic levels were reached and substantially reduced the ultimate endemic level. When introduced in a setting with endemic MRSA, it was shown that the isolation ward could always be expected to reduce MRSA levels, and if sufficiently large, and with a sufficient rate of detection of MRSA patients, could ultimately lead to eradication, albeit over a period of several years.

Cost savings associated with the use of an IW were estimated by combining locally gathered contemporary costing data with transmission models. Estimates were hampered by the paucity of reliable information on key parameter values. In particular, reliable attribution of additional LOS caused by MRSA infection was not possible from either clinical or statistical evidence. Moreover, assuming the additional stay attributable to infection to be at least 6 days, such additional stays made by far the largest contribution to the total costs, and results were highly sensitive to this parameter. Nonetheless, substantial costs savings could be achieved over 10 years compared with a policy of no isolation, provided that (i) without the intervention a sufficiently high endemic level would have been established (~20 infected patients) and (ii) the burden of unused IW capacity and concomitant staff time was not too great. This effect held true over a wide range of values (number of additional days' stay attributable to infection and cost per bed day).

Conclusions and implications for healthcare and research

Conclusions

This systematic review has several advantages over previous narrative reviews. Being systematic, it should not be vulnerable to authors' prejudices or to bias in study selection. The search strategy was highly comprehensive and data extraction provided systematic assessment of threats to the validity of evidence. Most importantly, it has identified the limitations of existing research and, together with the modelling, has provided testable hypotheses for future research.

Implications for healthcare

The literature review found evidence that intensive concerted interventions that include isolation can substantially reduce MRSA, even in settings with a high level of endemic MRSA. Little evidence was found to suggest that current isolation measures recommended in the UK are ineffective and these should continue to be applied until further research establishes otherwise. The commonest isolation policy in the UK is single-room isolation, with cohorting in bays if needed, because resources for IWs or NC are often unavailable. In this context, the studies by Harbarth and colleagues⁹² and Cosseron-Zerbib and colleagues⁸⁴ are of particular interest as these used such a policy, in combination with intensive use of other measures.

The current UK MRSA control guidelines describe management options dependent on the patient group, MRSA endemicity and virulence, and the availability of isolation facilities. The major constraint in modelling all these options proved to be lack of reliable data for individual patient groups in the literature. We therefore gave priority to modelling a whole hospital population.

The modelling results suggested that control of MRSA by detection and isolation is feasible over a large range of settings. However, the results of the modelling demonstrate that isolation policies are vulnerable to failure by becoming overwhelmed. Isolation policies will fail if not appropriately managed and resourced, and we recommend that MRSA management strategies be reviewed by individual hospitals in the light of these results.

Few authors reported detailed information on potentially important effect modifiers such as LOS, occupancy, staffing levels, antibiotic use, hand-hygiene and numbers colonised on admission. Consideration should be given to providing audit resources to ICTs to enable them systematically to collect and analyse such data. This could help in the planning of interventions and interpretation of their effects. Such an audit system requires careful design, piloting and validation (see research recommendation below).

Recommendations for future research

1. Study design

- (a) Future research should concentrate on designs that take measures to protect against the many threats to internal validity. In particular, there is a need for planned

comparisons, with predefined pre- and postintervention periods, with systematic assessment and adjustment for confounders. Most important, the decision to intervene and report should not be based on outcome data included in the study, in order to overcome systematic biases such as regression to the mean and reporting bias. Many designs are acceptable. *Table 8* summarises strengths and weaknesses associated with a number of possible designs. A fuller discussion of ITS designs is available elsewhere,⁵² as is comprehensive treatment of strengths and weaknesses of other designs.¹⁴¹⁻¹⁴⁵

- (b) RCTs are valuable as, if conducted well, they can eliminate most sources of bias, although selectivity of populations may create difficulty in generalising results.¹⁴¹ The communicable nature of MRSA means that individual patients will not be independent and cluster randomisation will usually be required, where the unit of randomisation is the hospital or unit.
 - (c) Consideration should be given to well-designed prospective ITS studies that conform to the parameters above [see (a)]. These may be more feasible than RCTs and better than poorly conducted or designed RCTs.¹⁴¹ Consideration should be given to multi-centre designs for such studies.
 - (d) Authors conducting such research should seek expert statistical advice at the planning stage.
2. A priority research question that evolves from both the modelling and the review is an examination of the effect of adequately sized IWs in hospitals with endemic MRSA. IWs were considered to have the strongest theoretical rationale and, if shown to be effective, would have the greatest implications for resource allocation and organisation of services.
 3. Other priority research questions include: the effects of single-room isolation with an extensive hand-hygiene programme, screening and eradication, and NC, with screening and eradication. Study designs that permit the identification of the effects of both individual interventions, such as antibiotic or hand-hygiene policies, and combinations of interventions should be considered.
 4. Consideration should be given to planned studies based on survey data, which would avoid biases associated with reporting and regression to the mean effects, and base their conclusions on a comprehensive sample.

TABLE 8 The strengths and weaknesses of selected study designs for studying MRSA transmission

Study design	Strengths	Weaknesses
Prospective designs		
(a) General considerations	<ol style="list-style-type: none"> 1. Threats to validity due to reporting bias and regression to the mean can be reduced or eliminated 2. Greater potential to eliminate threats to internal validity 3. Standardised protocol and data collection possible 	<ol style="list-style-type: none"> 1. Blinding may be impractical, leading to threats to construct validity (e.g. Hawthorne effects) and internal validity due to detection (information) bias 2. Potential limits to external validity (generalisability). Participating centres may be unrepresentative 3. May be impractical for studying effects over longer timescales
(b) Cluster randomised controlled trial	<ol style="list-style-type: none"> 1. Selection bias can be eliminated 2. Unmeasured confounding factors should be balanced between comparison groups 3. Experimental units independent so results can be analysed using standard statistical methods 	<ol style="list-style-type: none"> 1. Large number of study units may be required to achieve balance between comparison groups 2. Expensive
(c) ITS (all phases prospective, i.e. phase 1 data do not prompt the intervention)	<ol style="list-style-type: none"> 1. Study populations act as their own controls, reducing threat of selection bias 2. Case-mix differences unlikely to exist 3. Threats due to regression to the mean can be eliminated 4. Relatively cheap 	<ol style="list-style-type: none"> 1. Many threats to internal validity must be addressed (including confounders, seasonality, trends) 2. Effects of intervention phase may contaminate control phase if insufficient time for 'washout' 3. More complex statistical analysis required
(d) Single-phase time series studies	<ol style="list-style-type: none"> 1. May be valuable for studying trends, correlations, ecological interactions, costs etc. Valuable for generating hypotheses 2. Cheap 	<ol style="list-style-type: none"> 1. Of no value for assessing interventions owing to lack of reference group unless data are collected in enough detail to create within-phase comparison groups
Retrospective designs		
(a) General considerations	<ol style="list-style-type: none"> 1. May be easier to select more representative populations 2. Long time series may be available and valuable for studying outcomes over longer timescales 	<ol style="list-style-type: none"> 1. Opportunities to control for confounders may be limited 2. Threats to validity due to reporting bias and regression to mean
(b) ITS series (retrospective, or hybrid with phase 1 retrospective, phase 2 prospective)	<ol style="list-style-type: none"> 1. Study populations can act as their own controls, reducing selection bias 2. Cheap 	<ol style="list-style-type: none"> 1. Unless decision to report is made independently of data, large reporting bias likely 2. May be vulnerable to regression to mean effects 3. All the weaknesses associated with prospective interrupted time series studies
(c) Multicentre retrospective cohort studies (cohorts defined by different hospitals or units)	<ol style="list-style-type: none"> 1. Study populations may be more representative and results more generalisable 2. Reporting bias associated with unplanned retrospective reports less likely 3. Relatively cheap 	<ol style="list-style-type: none"> 1. Vulnerable to selection bias 2. Confounding factors may not have been measured in similar ways
(d) Outbreak reports	<ol style="list-style-type: none"> 1. May be valuable for communicating experiences, indicating new threats and generating hypotheses 2. Cheap 	<ol style="list-style-type: none"> 1. Large reporting bias likely to be associated with design. Regression to mean effects likely. Many threats to internal validity 2. Do not provide a valid basis for making inferences about interventions

5. An audit system that enables ICTs to collect and use data on potential effect modifiers (such as antibiotic use, hand-hygiene and staffing levels) alongside current MRSA surveillance systems needs to be designed, piloted and evaluated. Evaluation should focus on the role of the system in planning interventions and interpreting their outcomes.
6. Future outbreak reports and intervention studies should be written up in a standardised manner (see proposed guidelines, Appendix 5) with full recording of interventions, outcomes and confounders to ensure that specific threats to validity are addressed. We have produced guidelines to facilitate this. We emphasise the need for reports to distinguish between outcome data which are reported because they are considered inherently interesting, and outcomes reported because a decision had been made to report before examination of the data.
7. There is a pressing need for more accurate assessments of the resources used and the costs associated with MRSA infections and interventions. The resource use should be compiled in a comprehensive and consistent way and the opportunity costs of the use of these resources should be estimated.
8. Methodological research for the analysis of data generated by outbreak investigations is required. Specifically, a formal assessment of different approaches to analysing time series of count data as typically arise from hospital epidemics would be valuable and would aid interpretation of routine data collection.



Acknowledgements

We wish to thank the following.

For discussions: Matthias Egger, Jonathan Sterne and Peter Jüni of the Department of Social Medicine, University of Bristol; Graham Mowatt of EPOC; Barney Reeves at London School of Hygiene and Tropical Medicine; and Thames Valley University EPIC systematic review team.

For translations: Tanishka Norris; Eva Khossousi; Frank M Mattes; Esmee Rotmans; Satoshi Hori; Hiro Nori; and Marjan Brazier.

For responses: The many authors who responded to our queries: they are too many to list, but contradicted informed opinion that said contacting authors would be unproductive.

For other assistance: Stephanie Hudson, Esmee Rotmans, Dana Koheji, Jessica Jones (Secretaries at Royal Free); Greta Howell (Secretary to Barry Cookson); Rachel Lewis (Contracts Office); Sheena Thorne (Costing Accountant); Aileen Clarke; Simon How (Pathology Business Manager); Dr Robert Urquhart (Principal Pharmacist); and Karen Hamilton (Pharmacy Manager)

Finally, and especially, Mrs Charlotte Stone (aka Dr Pratt) and Sara Ita (aged 4), Rebecca Molly (aged 2) and David Dov Baer (aged 4 months) who did without their husband and Daddy on many evenings, early mornings and Sundays during the writing up stage of the review.



References

1. Reacher MH, Shah A, Livermore DM, Wale MC, Graham C, Johnson AP, *et al.* Bacteraemia and antibiotic resistance of its pathogens reported in England and Wales between 1990 and 1998: trend analysis. *BMJ* 2000;**320**:213–16.
2. *Staphylococcus aureus* bacteraemia: England and Wales January to December 2000. Communicable Disease Report. *CDR Wkly* 15 February 2001; 11:7. Available at <http://www.hpa.org.uk/cdr/PDFfiles/2001/cdr0701.pdf>
3. First report of the Department of Health's mandatory MRSA bacteraemia surveillance scheme in acute NHS Trusts in England: April to September 2001. Communicable Disease Report. *CDR Wkly* 7 February 2002; 12:6. <http://www.hpa.org.uk/cdr/PDFfiles/2002/cdr0602.pdf>
4. British Society for Antimicrobial Chemotherapy, Hospital Infection Society and the Infection Control Nurses Association. Revised guidelines for the control of methicillin-resistant *Staphylococcus aureus* infection in hospitals. *J Hosp Infect* 1998;**39**:253–90.
5. Williams REO. Healthy carriage of *Staphylococcus aureus*: its prevalence and importance. *Bacteriol Rev* 1963;**27**:56.
6. Lee YL, Cesario T, Pax A, Tran C, Ghouri A, Thrupp LD. Nasal colonization by *Staphylococcus aureus* in active, independent, community seniors. *Age Ageing* 1999;**28**:229–32.
7. Mulligan ME, Murray-Leisure KA, Ribner BS, Standiford HC, John JF, Korvick JA, *et al.* Methicillin-resistant *Staphylococcus aureus*: a consensus review of the microbiology, pathogenesis, and epidemiology with implications for prevention and management. *Am J Med* 1993;**94**:313–28.
8. Cookson B, Peters B, Webster M, Phillips I, Rahman M, Noble W. Staff carriage of epidemic methicillin-resistant *Staphylococcus aureus*. *J Clin Microbiol* 1989;**27**:1471–6.
9. Rammelkamp CH, Mortimer EA, Wolinsky E. Transmission of streptococcal and staphylococcal infections. *Ann Intern Med* 1964;**60**:753–8.
10. Peacock JE, Marsik FJ, Wenzel RP. Methicillin-resistant *Staphylococcus aureus*: introduction and spread within a hospital. *Ann Intern Med* 1980;**93**:526–32.
11. Thompson RL, Cabezudo I, Wenzel RP. Epidemiology of nosocomial infections caused by methicillin-resistant *Staphylococcus aureus*. *Ann Intern Med* 1982;**97**:309–17.
12. French GL, Cheng AF, Ling JM, Mo P, Donnan S. Hong Kong strains of methicillin-resistant and methicillin-sensitive *Staphylococcus aureus* have similar virulence. *J Hosp Infect* 1990;**15**:117–25.
13. Meers PD, Leong KY. The impact of methicillin- and aminoglycoside-resistant *Staphylococcus aureus* on the pattern of hospital-acquired infection in an acute hospital. *J Hosp Infect* 1990;**16**:231–9.
14. Peacock JE, Moorman DR, Wenzel RP, Mandell GL. Methicillin-resistant *Staphylococcus aureus*: microbiologic characteristics, antimicrobial susceptibilities, and assessment of virulence of an epidemic strain. *J Infect Dis* 1981;**144**:575–82.
15. Marty L, Flahault A, Suarez B, Caillon J, Hill C, Andremont A. Resistance to methicillin and virulence of *Staphylococcus aureus* strains in bacteriemic cancer patients. *Intensive Care Med* 1993;**19**:285–9.
16. Cheng AF, French GL. Methicillin-resistant *Staphylococcus aureus* bacteraemia in Hong Kong. *J Hosp Infect* 1988;**12**:91–101.
17. Crossley K, Loesch D, Landsman B. An outbreak of infections caused by strains of *Staphylococcus aureus* resistant to methicillin and aminoglycosides 2. Epidemiological studies. *J Infect Dis* 1979; **139**:280–7.
18. North EA. Acquired resistance of staphylococci to the action of penicillin. *Med J Aust* 1946;**1**:176–9.
19. Barber M, Rozwadowska-Dowzenko M. Infection by penicillin-resistant staphylococci. *Lancet* 1948; **ii**:641.
20. Barber M. Staphylococcal infection due to penicillin resistant strains. *BMJ* 1947;863–72.
21. Bulger R, Sherris JC. Decreased incidence of antibiotic resistance among *Staphylococcus aureus*: a study in a university hospital over a nine year period. *Ann Intern Med* 1968;**69**:1099–108.
22. Knudsen ET, Rolinson GN. Absorption and excretion of a new antibiotic (BRL 1241). *BMJ* 1960;**ii**:700.
23. Jevon MP. 'Celbenin' – resistant staphylococci. *BMJ* 1961;**i**:124–5.
24. Rosendal, K. Current national patterns. In Proceedings of International Conference on Nosocomial Infections. CDC 1970. Baltimore, MD: Waverly Press; 1971.
25. Benner EJ, Kayser FH. Growing clinical significance of methicillin-resistant *Staphylococcus aureus*. *Lancet* 1968;**ii**:741–4.

26. Parker MT, Hewitt JH. Methicillin resistance in *Staphylococcus aureus*. *Lancet* 1970;**i**:800–4.
27. Shanson DC. Antibiotic-resistant *Staphylococcus aureus*. *J Hosp Infect* 1981;**2**:11–36.
28. Shanson DC, Kensit JC, Duke R. Outbreak of hospital infection with a strain of *Staphylococcus aureus* resistant to gentamicin and methicillin. *Lancet* 1976;**ii**:1347–8.
29. Townsend DE, Ashdown N, Bradley JM, Pearman JW, Grubb WB. 'Australian' methicillin-resistant *Staphylococcus aureus* in a London hospital? *Med J Aust* 1985;**141**:339–40.
30. Townsend DE, Ashdown N, Bolton S, Bradley J, Duckworth G, Moorhouse EC, *et al*. The international spread of methicillin-resistant *Staphylococcus aureus*. *J Hosp Infect* 1987;**9**:60–71.
31. Cox RA, Conquest C, Mallaghan C, Marples RR. A major outbreak of methicillin-resistant *Staphylococcus aureus* caused by a new phage-type (EMRSA-16). *J Hosp Infect* 1995;**29**:87–106.
32. Kerr S, Kerr GE, Mackintosh CA, Marples RR. A survey of methicillin-resistant *Staphylococcus aureus* affecting patients in England and Wales. *J Hosp Infect* 1990;**16**:35–48.
33. Hiramatsu K, Hanaki H, Ino T. Methicillin resistant *Staphylococcus aureus* clinical strain with reduced vancomycin susceptibility. *J Antimicrob Chemother* 1997;**40**:135–6.
34. Howe RA, Bowker KE, Walsh TR, Feest TG, MacGowan AP. Vancomycin-resistant *Staphylococcus aureus*. *Lancet* 1998;**351**:602.
35. Chien JW, Kucia ML, Salata RA. Use of linezolid, an oxazolidinone, in the treatment of multidrug-resistant Gram-positive bacterial infections. *Clin Infect Dis* 2000;**30**:146–51.
36. Tsiodras S, Gold HS, Sakoulas G, Eliopoulos GM, Wennersten C, Venkataraman L, *et al*. Linezolid resistance in a clinical isolate of *Staphylococcus aureus*. *Lancet* 2001;**358**:207–8.
37. CDC. *Staphylococcus aureus* resistant to vancomycin – United States, 2002. *MMWR Morb Mortal Wkly Rep* 2002;**51**:565–7.
38. Schentag JJ, Hyatt JM, Carr JR, Paladino JA, Birmingham MC, Zimmer GS, *et al*. Genesis of methicillin-resistant *Staphylococcus aureus* (MRSA), how treatment of MRSA infections has selected for vancomycin-resistant *Enterococcus faecium*, and the importance of antibiotic management and infection control. *Clin Infect Dis* 1998;**26**:1204–14.
39. Cafferkey MT, Hone R, Coleman D, Pomeroy H, McGrath B, Ruddy R, *et al*. Methicillin-resistant *Staphylococcus aureus* in Dublin 1971–84. *Lancet* 1985;**ii**:705–8.
40. Hospital Infection Society, British Society for Antimicrobial Chemotherapy. Guidelines for the control of epidemic methicillin-resistant *Staphylococcus aureus*. Report of a combined working party of the Hospital Infection Society and British Society for Antimicrobial Chemotherapy. *J Hosp Infect* 1986;**7**:193–201.
41. Hospital Infection Society, British Society for Antimicrobial Chemotherapy. Revised guidelines for the control of epidemic methicillin-resistant *Staphylococcus aureus*. Report of a combined working party of the Hospital Infection Society and British Society for Antimicrobial Chemotherapy. *J Hosp Infect* 1990;**16**:351–77.
42. Tarzi S, Kennedy P, Stone S, Evans M. Methicillin resistant *Staphylococcus aureus* (MRSA): psychological impact of hospitalisation and isolation in an older adult population. *J Hosp Infect* 2001;**49**:250–54.
43. Boyce JM. Nosocomial staphylococcal infections. *Ann Intern Med* 1981;**95**:241–2.
44. Stone SP. Managing methicillin-resistant *Staphylococcus aureus* in hospital: the balance of risk. *Age Ageing* 1997;**26**:165–8.
45. Duckworth GJ. Diagnosis and management of methicillin resistant *Staphylococcus aureus* infection. *BMJ* 1993;**307**:1049–52.
46. Cookson BD. Is it time to stop searching for MRSA? *BMJ* 1997;**314**:664–5.
47. Teare EL, Barrett SP. Is it time to stop searching for MRSA? Stop the ritual of tracing colonised people. *BMJ* 1997;**314**:665–6.
48. Bowler IC, Storr JA. Costs of endemic MRSA. *J Hosp Infect* 1998;**40**:159.
49. Cookson BD, Valtz N, Marples R. UK infection control team (ICT) methicillin resistant *Staphylococcus aureus* (MRSA) questionnaire: control data. *J Hosp Infect* 1998; Suppl A:3.1.6.8.
50. Barrett SP, Teare EL, Sage R. Methicillin resistant *Staphylococcus aureus* in three adjacent health districts of south-east England 1986–91. *J Hosp Infect* 1993;**24**:313–25.
51. Cooper BS, Medley GF, Scott GM. Preliminary analysis of the transmission dynamics of nosocomial infections: stochastic and management effects. *J Hosp Infect* 1999;**43**:131–47.
52. Cook TD, Campbell DT. Quasi-experimentation: design and analysis issues for field settings. Chicago: Rand McNally College Publications; 1979.
53. Grundmann H, Hori S, Winter B, Tami A, Austin DJ. Risk factors for the transmission of methicillin-resistant *Staphylococcus aureus* in an adult intensive care unit: fitting a model to the data. *J Infect Dis* 2002;**185**:481–8.
54. Larson E. A causal link between handwashing and risk of infection? Examination of the evidence. *Infect Control* 1988;**9**:28–36.

55. Yoshida J, Kuroki S, Akazawa K, Chijiwa K, Takemori K, Torisu M, *et al.* The order of ward rounds influences nosocomial infection. A 2-year study in gastroenterologic surgery patients. *J Gastroenterol* 1995;**30**:718–24.
56. Landman D, Chockalingam M, Quale JM. Reduction in the incidence of methicillin-resistant *Staphylococcus aureus* and ceftazidime-resistant *Klebsiella pneumoniae* following changes in a hospital antibiotic formulary. *Clin Infect Dis* 1999;**28**:1062–66.
57. Onesko KM, Wienke EC. The analysis of the impact of a mild, low-iodine, lotion soap on the reduction of nosocomial methicillin-resistant *Staphylococcus aureus*: a new opportunity for surveillance by objectives. *Infect Control* 1987;**8**:255–88.
58. Kibbler CC, Quick A, O'Neill AM. The effect of increased bed numbers on MRSA transmission in acute medical wards. *J Hosp Infect* 1998;**39**:213–19.
59. Casewell MW. New threats to the control of methicillin-resistant *Staphylococcus aureus*. *J Hosp Infect* 1995;**30** (Suppl.):465–71.
60. Cookson BD. Methicillin-resistant *Staphylococcus aureus* in the community: new battlefronts, or are the battles lost? *Infect Control Hosp Epidemiol* 2000;**21**:398–403.
61. Aly R, Maibach HI, Shinefield HR, Mandel A, Strauss WG. Bacterial interference among strains of *Staphylococcus aureus* in man. *J Infect Dis* 1974;**129**:720–4.
62. Uehara Y, Nakama H, Agematsu K, Uchida M, Kawakami Y, Abdul F, *et al.* Bacterial interference among nasal inhabitants: eradication of *Staphylococcus aureus* from nasal cavities by artificial implantation of *Corynebacterium* sp. *J Hosp Infect* 2000;**44**:127–33.
63. Parsons HM. What happened at Hawthorne? *Science* 1974;**183**:922–32.
64. Sterne JA, Davey Smith G. Sifting the evidence – what's wrong with significance tests? *BMJ* 2001;**322**:226–31.
65. Selvin S. Statistical analysis of epidemiological data. Oxford: Oxford University Press; 1996. Ch. 6.
66. Ihaka R, Gentleman R. R: a language for data analysis and graphics. *J Comput Graph Stat* 1996;**5**:299–314.
67. Becker NG. Analysis of infectious disease data. London: Chapman and Hall; 1989.
68. Starr JM, Campbell A. Mathematical modeling of *Clostridium difficile* infection. *Clin Microbiol Infect* 2001;**7**:432–7.
69. Cooper BS. The transmission dynamics of methicillin-resistant *Staphylococcus aureus* and vancomycin-resistant enterococci in hospital wards. Coventry: University of Warwick; 2000.
70. Merrer J, Santoli F, Appere de Vecchi C, Tran B, De Jonghe B, Outin H. 'Colonization pressure' and risk of acquisition of methicillin-resistant *Staphylococcus aureus* in a medical intensive care unit. *Infect Control Hosp Epidemiol* 2000;**21**:718–23.
71. Bonten MJ, Slaughter S, Ambergen AW, Hayden MK, van Voorhis J, Nathan C, *et al.* The role of 'colonization pressure' in the spread of vancomycin-resistant enterococci: an important infection control variable. *Arch Intern Med* 1998;**158**:1127–32.
72. Lopez-Lozano JM, Monnet DL, Yague A, Burgos A, Gonzalo N, Campillos P, *et al.* Modelling and forecasting antimicrobial resistance and its dynamic relationship to antimicrobial use: a time series analysis. *Int J Antimicrob Agents* 2000;**14**:21–31.
73. The Cochrane Effective Practice and Organisation of Care (EPOC) Review Group. *Cochrane Library Database* 2000.
74. University Minnesota. Supercomputing Institute. Data Thief II 2002. www.nikhef.nl/~keeshu/datathief/index.html
75. Stone SP, Beric V, Quick A, Balestrini AA, Kibbler CC. The effect of an enhanced infection-control policy on the incidence of *Clostridium difficile* infection and methicillin-resistant *Staphylococcus aureus* colonization in acute elderly medical patients. *Age Ageing* 1998;**27**:561–8.
76. Faoagali JL, Thong ML, Grant D. Ten years' experience with methicillin-resistant *Staphylococcus aureus* in a large Australian hospital. *J Hosp Infect* 1992;**20**:113–19.
77. Brady LM, Thomson M, Palmer MA, Harkness JL. Successful control of endemic MRSA in a cardiothoracic surgical unit. *Med J Aust* 1990;**152**:240–5.
78. Souweine B, Traore O, Aublet-Cuvelier B, Bret L, Sirot J, Laveran H, *et al.* Role of infection control measures in limiting morbidity associated with multi-resistant organisms in critically ill patients. *J Hosp Infect* 2000;**45**:107–16.
79. Arnow P, Allyn PA, Nichols EM, Hill DL, Pezzlo M, Bartlett RH. Control of methicillin-resistant *Staphylococcus aureus* in a burn unit: role of nurse staffing. *J Trauma* 1982;**22**:954–9.
80. Pittet D, Hugonnet S, Harbarth S, Mourouga P, Sauvan V, Touveneau S, *et al.* Effectiveness of a hospital-wide programme to improve compliance with hand hygiene. *Lancet* 2000;**356**:1307–12.
81. Blumberg LH, Klugman KP. Control of methicillin-resistant *Staphylococcus aureus* bacteraemia in high-risk areas. *Eur J Clin Microbiol Infect Dis* 1994;**13**:82–5.

82. Selkon JB, Stokes ER, Ingham HR. The role of an isolation unit in the control of hospital infection with methicillin-resistant staphylococci. *J Hosp Infect* 1980;**1**:41–6.
83. Murray-Leisure KA, Geib S, Graceley D, Rubin-Slutsky AB, Saxena N, Muller HA, *et al.* Control of epidemic methicillin-resistant *Staphylococcus aureus*. *Infect Control Hosp Epidemiol* 1990;**11**:343–50.
84. Cosseron-Zerbib M, Roque Afonso AM, Naas T, Durand P, Meyer L, Costa Y, *et al.* A control programme for MRSA (methicillin-resistant *Staphylococcus aureus*) containment in a paediatric intensive care unit: evaluation and impact on infections caused by other micro-organisms. *J Hosp Infect* 1998;**40**:225–35.
85. Campbell JR, Zaccaria E, Mason EO Jr, Baker CJ. Epidemiological analysis defining concurrent outbreaks of *Serratia marcescens* and methicillin-resistant *Staphylococcus aureus* in a neonatal intensive-care unit. *Infect Control Hosp Epidemiol* 1998;**19**:924–8.
86. Farrington M, Trundle C, Redpath C, Anderson L. Effects on nursing workload of different methicillin-resistant *Staphylococcus aureus* (MRSA) control strategies. *J Hosp Infect* 2000;**46**:118–22.
87. El Hagrasy M. An outbreak of methicillin-resistant *Staphylococcus aureus* (MRSA) in a hospital in the UAE: problems and solutions. *Emirates Med J* 1997;**15**:17–21.
88. Cox RA, Conquest C, Mallaghan C, Marples RR. A major outbreak of methicillin-resistant *Staphylococcus aureus* caused by a new phage-type (EMRSA-16). *J Hosp Infect* 1995;**29**:87–106.
89. Duckworth GJ, Lothian JL, Williams JD. Methicillin-resistant *Staphylococcus aureus*: report of an outbreak in a London teaching hospital. *J Hosp Infect* 1988;**11**:1–15.
90. Tambic A, Power EG, Tambic T, Snur I, French GL. Epidemiological analysis of methicillin-resistant *Staphylococcus aureus* in a Zagreb Trauma Hospital using a randomly amplified polymorphic DNA-typing method. *Eur J Clin Microbiol & Infect Dis* 1999;**18**:335–40.
91. Farrington M, Redpath C, Trundle C, Coomber S, Brown NM. Winning the battle but losing the war: methicillin-resistant *Staphylococcus aureus* (MRSA) infection at a teaching hospital. *QJM* 1998;**91**:539–48.
92. Harbarth S, Martin Y, Rohner P, Henry N, Auckenthaler R, Pittet D. Effect of delayed infection control measures on a hospital outbreak of methicillin-resistant *Staphylococcus aureus*. *J Hosp Infect* 2000;**46**:43–9.
93. Girou E, Azar J, Wolkenstein P, Cizeau F, Brun-Buisson C, Roujeau JC. Comparison of systematic versus selective screening for methicillin-resistant *Staphylococcus aureus* carriage in a high-risk dermatology ward. *Infect Control Hosp Epidemiol* 2000;**21**:583–7.
94. Girou E, Pujade G, Legrand P, Cizeau F, Brun-Buisson C. Selective screening of carriers for control of methicillin-resistant *Staphylococcus aureus* (MRSA) in high-risk hospital areas with a high level of endemic MRSA. *Clin Infect Dis* 1998;**27**:543–50.
95. Jernigan JA, Titus MG, Groschel DH, Getchell-White S, Farr BM. Effectiveness of contact isolation during a hospital outbreak of methicillin-resistant *Staphylococcus aureus*. *Am J Epidemiol* 1996;**143**:496–504.
96. Linnemann CC, Jr., Mason M, Moore P, Korfhagen TR, Stanek JL. Methicillin-resistant *Staphylococcus aureus*: experience in a general hospital over four years. *Am J Epidemiol* 1982;**115**:941–50.
97. Kac G, Buu-Hoi A, Herisson E, Biancardini P, Debure C. Methicillin-resistant *Staphylococcus aureus*. Nosocomial acquisition and carrier state in a wound care center. *Arch Dermatol* 2000;**136**:735–9.
98. Pearman JW, Christiansen KJ, Annear DI, Goodwin CS, Metcalf C, Donovan FP, *et al.* Control of methicillin-resistant *Staphylococcus aureus* (MRSA) in an Australian metropolitan teaching hospital complex. *Med J Aust* 1985;**142**:103–8.
99. Alvarez S, Shell C, Gage K, Guarderas J, Kasprzyk D, Besing J, *et al.* An outbreak of methicillin-resistant *Staphylococcus aureus* eradicated from a large teaching hospital. *Am J Infect Control* 1985;**13**:115–21.
100. Ward TT, Winn RE, Hartstein AI, Sewell DL. Observations relating to an inter-hospital outbreak of methicillin-resistant *Staphylococcus aureus*: role of antimicrobial therapy in infection control. *Infect Control* 1981;**2**:453–9.
101. Oto MA, Pinto CME, Martinez CV, Fabio BC, Soza MA, Jerez RA, *et al.* Control of methicillin resistant *Staphylococcus aureus* at a neonatal ward. *Rev Chil Pediatr* 1992;**63**:134–8.
102. Talon D, Rouget C, Cailleaux V, Bailly P, Thouverez M, Barale F, *et al.* Nasal carriage of *Staphylococcus aureus* and cross-contamination in a surgical intensive care unit: efficacy of mupirocin ointment. *J Hosp Infect* 1995;**30**:39–49.
103. Jones MR, Martin DR. Outbreak of methicillin-resistant *Staphylococcus aureus* infection in a New Zealand hospital. *N Z Med J* 1987;**100**:369–73.
104. Lugeon C, Blanc DS, Wenger A, Francioli P. Molecular epidemiology of methicillin-resistant *Staphylococcus aureus* at a low-incidence hospital over a 4-year period. *Infect Control Hosp Epidemiol* 1995;**16**:260–7.

105. Schlünzen L, Lund B, Schouenborg P, Skov RL. Outbreak of methicillin resistant *Staphylococcus aureus* in a central hospital. *Ugeskr Laeger* 1997; **159**:431–5.
106. Papia G, Louie M, Tralla A, Johnson C, Collins V, Simor AE. Screening high-risk patients for methicillin-resistant *Staphylococcus aureus* on admission to the hospital: is it cost effective? *Infect Control Hosp Epidemiol* 1999; **20**:473–7.
107. Barakate MS, Harris JP, West RH, Vickery AM, Sharp CA, Macleod C, *et al.* A prospective survey of current methicillin-resistant *Staphylococcus aureus* control measures. *Aust N Z J Surg* 1999; **69**:712–16.
108. Hartstein AI, LeMonte AM, Iwamoto PK. DNA typing and control of methicillin-resistant *Staphylococcus aureus* at two affiliated hospitals. *Infect Control Hosp Epidemiol* 1997; **18**:42–8.
109. Esveld MI, de Boer AS, Notenboom AJ, van Pelt W, van Leeuwen WJ. Secondary infection with methicillin resistant *Staphylococcus aureus* in Dutch hospitals July 1994–June 1996. *Ned Tijdschr Geneesk* 1999; **143**:205–8.
110. Ribner BS, Landry MN, Gholson GL. Strict versus modified isolation for prevention of nosocomial transmission of methicillin-resistant *Staphylococcus aureus*. *Infect Control* 1986; **7**:317–20.
111. Shanson DC, Johnstone D, Midgley J. Control of a hospital outbreak of methicillin-resistant *Staphylococcus aureus* infections: value of an isolation unit. *J Hosp Infect* 1985; **6**:285–92.
112. Pfaller MA, Wakefield DS, Hollis R, Frederickson M, Evans E, Massanari RM. The clinical microbiology laboratory as an aid in infection control. The application of molecular techniques in epidemiologic studies of methicillin-resistant *Staphylococcus aureus*. *Diagn Microbiol Infect Dis* 1991; **14**:209–17.
113. Back NA, Linnemann CC Jr, Staneck JL, Kotagal UR. Control of methicillin-resistant *Staphylococcus aureus* in a neonatal intensive-care unit: use of intensive microbiologic surveillance and mupirocin. *Infect Control Hosp Epidemiol* 1996; **17**:227–31.
114. Yano M, Doki Y, Inoue M, Tsujinaka T, Shiozaki H, Monden M. Preoperative intranasal mupirocin ointment significantly reduces postoperative infection with *Staphylococcus aureus* in patients undergoing upper gastrointestinal surgery. *Surg Today* 2000; **30**:16–21.
115. Law MR, Gill ON, Turner A. Methicillin-resistant *Staphylococcus aureus*: associated morbidity and effectiveness of control measures. *Epidemiol Infect* 1988; **101**:301–9.
116. Ayliffe GA, Lilly HA, Lowbury EJ. Decline of the hospital *Staphylococcus*? Incidence of multiresistant *Staph. aureus* in three Birmingham hospitals. *Lancet* 1979; **i**:538–41.
117. Hall LE, Klein EG, Slater LN. A descriptive analysis of methicillin resistant *Staphylococcus aureus* in veterans. *Am J Infect Control* 1998; **16**:89 (abstract).
118. Coello R, Jimenez J, Garcia M, Arroyo P, Minguez D, Fernandez C, *et al.* Prospective study of infection, colonization and carriage of methicillin-resistant *Staphylococcus aureus* in an outbreak affecting 990 patients. *Eur J Clin Microbiol Infect Dis* 1994; **13**:74–81.
119. Mayall B, Martin R, Keenan AM, Irving L, Leeson P, Lamb K. Blanket use of intranasal mupirocin for outbreak control and long-term prophylaxis of endemic methicillin-resistant *Staphylococcus aureus* in an open ward. *J Hosp Infect* 1996; **32**:257–66.
120. Barakate MS, Yang YX, Foo SH, Vickery AM, Sharp CA, Fowler LD, *et al.* An epidemiological survey of methicillin-resistant *Staphylococcus aureus* in a tertiary referral hospital. *J Hosp Infect* 2000; **44**:19–26.
121. Austin DJ, Bonten MJ, Weinstein RA, Slaughter S, Anderson RM. Vancomycin-resistant enterococci in intensive-care hospital settings: transmission dynamics, persistence, and the impact of infection control programs. *Proc Natl Acad Sci USA* 1999; **96**:6908–13.
122. Austin DJ, Anderson RM. Transmission dynamics of epidemic methicillin-resistant *Staphylococcus aureus* and vancomycin-resistant enterococci in England and Wales. *J Infect Dis* 1999; **179**:883–91.
123. Lipsitch M, Bergstrom CT, Levin BR. The epidemiology of antibiotic resistance in hospitals: paradoxes and prescriptions. *Proc Natl Acad Sci USA* 2000; **97**:1938–43.
124. Sebille V, Chevret S, Valleron AJ. Modeling the spread of resistant nosocomial pathogens in an intensive-care unit. *Infect Control Hosp Epidemiol* 1997; **18**:55–92.
125. Grundmann H, Hori S, Winter B, Tami A, Austin DJ. Risk factors for the transmission of methicillin-resistant *Staphylococcus aureus* in an adult intensive care unit: fitting a model to the data. *J Infect Dis* 2002; **185**:481–8.
126. Jernigan JA, Clemence MA, Stott GA, Titus MG, Alexander CH, Palumbo, *et al.* Control of methicillin-resistant *Staphylococcus aureus* at a university hospital: one decade later. *Infect Control Hosp Epidemiol* 1995; **16**:686–96.
127. MacKinnon MM, Allen KD. Long-term MRSA carriage in hospital patients. *J Hosp Infect* 2000; **46**:216–21.
128. Beaujean DJ, Weersink AJ, Blok HE, Frenay HM, Verhoef J. Determining risk factors for methicillin-

- resistant *Staphylococcus aureus* carriage after discharge from hospital. *J Hosp Infect* 1999; **42**:213–18.
129. Scanvic A, Denic L, Gaillon S, Giry P, Andremont A, Lucet JC. Duration of colonization by methicillin-resistant *Staphylococcus aureus* after hospital discharge and risk factors for prolonged carriage. *Clin Infect Dis* 2001; **32**:1393–8.
130. Sanford MD, Widmer AF, Bale MJ, Jones RN, Wenzel RP. Efficient detection and long-term persistence of the carriage of methicillin-resistant *Staphylococcus aureus*. *Clin Infect Dis* 1994; **19**:1123–8.
131. Fitzpatrick F, Murphy OM, Brady A, Prout S, Fenelon LE. A purpose built MRSA cohort unit. *J Hosp Infect* 2000; **46**:271–9.
132. Abudu L, Blair I, Fraise A, Cheng KK. Methicillin-resistant *Staphylococcus aureus* (MRSA): a community-based prevalence survey. *Epidemiol Infect* 2001; **126**:351–6.
133. Stroup DF, Berlin JA, Morton SC, Olkin I, Williamson GD, Rennie D, *et al.* Meta-analysis of observational studies in epidemiology: a proposal for reporting. Meta-analysis Of Observational Studies in Epidemiology (MOOSE) group. *JAMA* 2000; **283**:2008–12.
134. Richet H, Wiesel M, Le Gallou F, André-Richet B, Espaze E. Methicillin-resistant *Staphylococcus aureus* control in hospitals: the French experience. Association des Pays de la Loire pour l'Eviction des Infections Nosocomiales. *Infect Control Hosp Epidemiol* 1996; **17**:509–11.
135. Trilla A, Marco F, Moreno AV, Prat A, Vila J, Bayas JM, *et al.* Prevention and control of methicillin-resistant *Staphylococcus aureus* nosocomial infection in Barcelona (Spain). *Chemotherapy* 1996; **42** (Suppl 2):53–9.
136. Struelens MJ, Ronveaux O, Jans B, Mertens R. Methicillin-resistant *Staphylococcus aureus* epidemiology and control in Belgian hospitals, 1991 to 1995. Groupement pour le Dépistage, l'Etude et la Prévention des Infections Hospitalières. *Infect Control Hosp Epidemiol* 1996; **17**:503–8.
137. Schmitz FJ, MacKenzie CR, Geisel R, Wagner S, Idel H, Verhoef J, *et al.* Methicillin resistant *Staphylococcus aureus* strains in the greater Dusseldorf area. *Eur J Epidemiol* 1997; **13**:709–17.
138. Juni P, Witschi A, Bloch R, Egger M. The hazards of scoring the quality of clinical trials for meta-analysis. *JAMA* 1999; **282**:1054–60.
139. Cameron CA, Trivedi PK. Regression analysis of count data. 1st ed. Cambridge: Cambridge University Press; 1998.
140. Pittet D, Safran E, Harbarth S, Borst F, Copin P, Rohner P, *et al.* Automatic alerts for methicillin-resistant *Staphylococcus aureus* surveillance and control: role of a hospital information system. *Infect Control Hosp Epidemiol* 1996; **17**:496–502.
141. Britton A, McKee M, Black N, McPherson K, Sanderson C, Bain C. Choosing between randomised and non-randomised studies: a systematic review. *Health Technol Assess* 1998; **2**:1–124.
142. Egger M, Davey Smith G, Altman D. Systematic reviews in health care: meta-analysis in context. London: BMJ Books; 2002.
143. Grimes DA, Schulz KF. Cohort studies: marching towards outcomes. *Lancet* 2002; **359**:341–5.
144. Grimes DA, Schulz KF. Descriptive studies: what they can and cannot do. *Lancet* 2002; **359**:145–9.
145. Hayes RJ, Alexander ND, Bennett S, Cousens SN. Design and analysis issues in cluster-randomized trials of interventions against infectious diseases. *Stat Methods Med Res* 2000; **9**:95–116.
146. Abramson MA, Sexton DJ. Nosocomial methicillin-resistant and methicillin-susceptible *Staphylococcus aureus* primary bacteremia: at what costs? *Infect Control Hosp Epidemiol* 1999; **20**:408–11.
147. Adeyemi-Doro FA, Scheel O, Lyon DJ, Cheng AF. Living with methicillin-resistant *Staphylococcus aureus*: a 7-year experience with endemic MRSA in a university hospital. *Infect Control Hosp Epidemiol* 1997; **18**:765–7.
148. Aihara M, Sakai M, Iwasaki M, Shimakawa K, Kozaki S, Kubo M, *et al.* Prevention and control of nosocomial infection caused by methicillin-resistant *Staphylococcus aureus* in a premature infant ward – preventive effect of a povidone-iodine wipe of neonatal skin. *Postgrad Med J* 1993; **69** (Suppl 3): S117–21.
149. Allen KD, Ridgway EJ, Parsons LA. Hexachlorophane powder and neonatal staphylococcal infection. *J Hosp Infect* 1994; **27**:29–33.
150. Ang SW, Lee ST. The pattern of burn infection in the Singapore National Burns Centre. *Ann Acad Med Singapore* 1997; **26**:599–603.
151. Asensio A, Guerrero A, Quereda C, Lizan M, Martinez-Ferrer M. Colonization and infection with methicillin-resistant *Staphylococcus aureus*: associated factors and eradication. *Infect Control Hosp Epidemiol* 1996; **17**:20–8.
152. Aubry-Damon H, Legrand P, Brun-Buisson C, Astier A, Soussy CJ, Leclercq R. Reemergence of gentamicin-susceptible strains of methicillin-resistant *Staphylococcus aureus*: roles of an infection control program and changes in aminoglycoside use. *Clin Infect Dis* 1997; **25**:647–53.
153. Bacon AE, Jorgensen KA, Wilson KH, Kauffman CA. Emergence of nosocomial methicillin-resistant

- Staphylococcus aureus* and therapy of colonized personnel during a hospital-wide outbreak. *Infect Control* 1987;**8**:145–50.
154. Bailly P, Mulin B, Minary P, Talon D. Control of methicillin-resistant *Staphylococcus aureus* infections in a university hospital: critical analysis of results. *Med Mal Infect* 1999;**29**:178–83.
 155. Barrett FF, McGehee RF, Jr., Finland M. Methicillin-resistant *Staphylococcus aureus* at Boston City Hospital. Bacteriologic and epidemiologic observations. *N Engl J Med* 1968;**279**:441–8.
 156. Barrett SP, Gill ON, Mellor JA, Bryant JC. A descriptive survey of uncontrolled methicillin-resistant *Staphylococcus aureus* in a twin site general hospital. *Postgrad Med J* 1988;**64**:606–9.
 157. Barrett SP. The value of nasal mupirocin in containing an outbreak of methicillin-resistant *staphylococcus aureus* in an orthopaedic unit. *J Hosp Infect* 1990;**15**:137–42.
 158. Barrett SP, Teare EL, Sage R. Methicillin resistant *Staphylococcus aureus* in three adjacent health districts of south-east England 1986–91. *J Hosp Infect* 1993;**24**:313–25.
 159. Bartzokas CA, Paton JH, Gibson MF, Graham F, McLoughlin GA, Croton RS, *et al.* Control and eradication of methicillin-resistant *Staphylococcus aureus* on a surgical unit. *N Engl J Med* 1985;**311**:1422–5.
 160. Bitar CM, Mayhall CG, Lamb VA, Bradshaw TJ, Spadora AC, Dalton HP. Outbreak due to methicillin- and rifampin-resistant *Staphylococcus aureus*: epidemiology and eradication of the resistant strain from the hospital. *Infect Control* 1987;**8**:15–23.
 161. Bock BV, Pasiencznik K, Meyer RD. Clinical and laboratory studies of nosocomial *Staphylococcus aureus* resistant to methicillin and aminoglycosides. *Infect Control* 1982;**3**:224–8.
 162. Bouchard O, Bosseray A, Queyrel V, Gavazzi G, Croize J, Leclercq P, *et al.* Experience with an isolation unit for patients infected with multiresistant bacteria: retrospective study of 49 patients. *Presse Med* 1999;**28**:1405–8.
 163. Boyce JM, Landry M, Deetz TR, DuPont HL. Epidemiologic studies of an outbreak of nosocomial methicillin-resistant *Staphylococcus aureus* infections. *Infect Control* 1981;**2**:110–16.
 164. Boyce JM, White RL, Causey WA, Lockwood WR. Burn units as a source of methicillin-resistant *Staphylococcus aureus* infections. *JAMA* 1983;**249**:2803–7.
 165. Boyce JM, Opal SM, Potter BG, Medeiros AA. Spread of methicillin-resistant *Staphylococcus aureus* in a hospital after exposure to a health care worker with chronic sinusitis. *Clin Infect Dis* 1993;**17**:496–504.
 166. Bradley JM, Noone P, Townsend DE, Grubb WB. Methicillin-resistant *Staphylococcus aureus* in a London hospital. *Lancet* 1985;**i**:1493–5.
 167. Brun Buisson BC, Rauss A, Legrand P, Mentec H, Ossart M, Eb F, *et al.* Mupirocin treatment of *S. aureus* nasal carriage and prevention of infection in intensive care units: a multicenter controlled study. *Med Mal Infect* 1994;**24**:1229–39.
 168. Campins M, Almar J, Rodriguez V, Jasa A, Ruiz MA, Gasser I. Newborn unit methicillin-resistant *Staphylococcus aureus* outbreak: efficacy of infection control measures. *Enferm Infecc Microbiol Clin* 1992;**10** (Suppl. 3):56–8.
 169. Cohen SH, Morita MM, Bradford M. A seven-year experience with methicillin-resistant *Staphylococcus aureus*. *Am J Med* 1991;**91**(3B):233S–237S.
 170. Coovadia YM, Bhana RH, Johnson AP, Haffejee I, Marples RR. A laboratory-confirmed outbreak of rifampicin-methicillin resistant *Staphylococcus aureus* (RMRSA) in a newborn nursery. *J Hosp Infect* 1989;**14**:303–12.
 171. Craven DE, Reed C, Kollisch N, DeMaria A, Lichtenberg D, Shen, McCabe WR. A large outbreak of infections caused by a strain of *Staphylococcus aureus* resistant to oxacillin and aminoglycosides. *Am J Med* 1981;**71**:53–8.
 172. Dacre J, Emmerson AM, Jenner EA. Gentamicin–methicillin-resistant *Staphylococcus aureus*: epidemiology and containment of an outbreak. *J Hosp Infect* 1986;**7**:130–6.
 173. Dancer SJ, Crawford A. Keeping MRSA out of a district general hospital. *J Hosp Infect* 1999;**43** Suppl:S19–27.
 174. Danchivijitr S, Chantrasakul C, Chokloikaew S, Trakoolsomboon S. An outbreak of methicillin-resistant *Staphylococcus aureus* (M.R.S.A.) in a burn unit. *J Med Assoc Thailand* 1995;**78** (Suppl. 1): S11–14.
 175. Darouiche R, Wright C, Hamill R, Koza M, Lewis D, Markowski J. Eradication of colonization by methicillin-resistant *Staphylococcus aureus* by using oral minocycline–rifampin and topical mupirocin. *Antimicrob Agents Chemother* 1991;**35**:1612–15.
 176. Davies EA, Emmerson AM, Hogg GM, Patterson MF, Shields MD. An outbreak of infection with a methicillin-resistant *Staphylococcus aureus* in a special care baby unit: value of topical mupirocin and of traditional methods of infection control. *J Hosp Infect* 1987;**10**:120–8.
 177. Dickson D, Czurylo K. The nursing management of an MRSA outbreak in an acute care facility. *Nurs Manage* 1988;**19**:22–4.
 178. Dunkle LM, Naqvi SH, McCallum R, Lofgren JP. Eradication of epidemic methicillin–gentamicin-resistant *Staphylococcus aureus* in an intensive care nursery. *Am J Med* 1981;**70**:455–8.

179. Dziekan G, Hahn A, Thune K, Schwarzer G, Schafer K, Daschner FD, *et al.* Methicillin-resistant *Staphylococcus aureus* in a teaching hospital: investigation of nosocomial transmission using a matched case-control study. *J Hosp Infect* 2000; **46**:263-70.
180. Fang FC, McClelland M, Guiney DG, Jackson MM, Hartstein AI, Morthland VH, *et al.* Value of molecular epidemiologic analysis in a nosocomial methicillin-resistant *Staphylococcus aureus* outbreak. *JAMA* 1993; **270**:1323-8.
181. Farrington M, Ling J, Ling T, French GL. Outbreaks of infection with methicillin-resistant *Staphylococcus aureus* on neonatal and burns units of a new hospital. *Epidemiol Infect* 1990; **105**:215-28.
182. Fazal BA, Telzak EE, Blum S, Turett GS, Petersen-Fitzpatrick FE, Lorian V. Trends in the prevalence of methicillin-resistant *Staphylococcus aureus* associated with discontinuation of an isolation policy. *Infect Control Hosp Epidemiol* 1996; **17**:372-4.
183. Finkelstein R, Markel A, Reinherz G, Hashman N, Merzbach D. The emergence of methicillin-resistant *Staphylococcus aureus* infections in an Israeli hospital. *J Hosp Infect* 1989; **14**:55-61.
184. Forward KR, Arbique JC. Cumulative yield from patient surveillance cultures for methicillin-resistant *Staphylococcus aureus* during a hospital outbreak. *Infect Control Hosp Epidemiol* 1997; **18**:776-8.
185. Fukatsu K, Saito H, Matsuda T, Ikeda S, Furukawa S, Muto T. Influences of type and duration of antimicrobial prophylaxis on an outbreak of methicillin-resistant *Staphylococcus aureus* and on the incidence of wound infection. *Arch Surg* 1997; **132**:1320-5.
186. Geldner G, Ruoff M, Hoffmann HJ, Kiefer P, Georgieff M, Wiedeck H. Cost analysis concerning MRSA-infection in ICU. *Anesthesiol Intensivmed Notfallmed Schmerzther* 1999; **34**:409-13.
187. Gerken MV. An outbreak of methicillin-resistant *Staphylococcus aureus* in a large medical center. *Am Surg* 1983; **49**:179-81.
188. Gilmore DS, Montgomerie JZ, Graham IE. Category 1, 2, 3 and 4: a procedure-oriented isolation system. *Infect Control* 1986; **7**:263-7.
189. Goetz AM, Muder RR. The problem of methicillin-resistant *Staphylococcus aureus*: a critical appraisal of the efficacy of infection control procedures with a suggested approach for infection control programs. *Am J Infect Control* 1992; **20**:80-4.
190. Goetz MB, Mulligan ME, Kwok R, O'Brien H, Caballes C, Garcia JP. Management and epidemiologic analyses of an outbreak due to methicillin-resistant *Staphylococcus aureus*. *Am J Med* 1992; **92**:607-14.
191. Gonzalez M, Elias M, Matute B, Garcia I, Calaf A. Follow-up and monitoring of MRSA after eradication of an outbreak of nosocomial infection. *Enferm Clin* 1996; **6**:82-5.
192. Guiguet M, Rekacewicz C, Leclercq B, Brun Y, Escudier B, Andreumont A. Effectiveness of simple measures to control an outbreak of nosocomial methicillin-resistant *Staphylococcus aureus* infections in an intensive care unit. *Infect Control Hosp Epidemiol* 1990; **11**:23-6.
193. Haddad Q, Sobayo EI, Basit OBA, Rotimi VO. Outbreak of methicillin-resistant *Staphylococcus aureus* in a neonatal intensive care unit. *J Hosp Infect* 1993; **23**:211-22.
194. Haiduven-Griffiths D. Outbreak of methicillin-resistant *Staphylococcus aureus* on a surgical service. *Am J Infect Control* 1988; **16**:123-7.
195. Haley RW, Cushion NB, Tenover FC, Bannerman TL, Dryer D, Ross J, *et al.* Eradication of endemic methicillin-resistant *Staphylococcus aureus* infections from a neonatal intensive care unit. *J Infect Dis* 1995; **171**:614-24.
196. Hansen B, Pedersen LN, Arpi M, Obel N. Incidence of methicillin-resistant *Staphylococcus aureus* among Kosovar-Albanian refugees at the refugee-centre in Randers. *Ugeskr Laeger* 2000; **162**:6241-3.
197. Hartstein AI, Denny MA, Morthland VH, LeMonte AM, Pfaller MA. Control of methicillin-resistant *Staphylococcus aureus* in a hospital and an intensive care unit. *Infect Control Hosp Epidemiol* 1995; **16**:405-11.
198. Hiramatsu N, Hashimoto S, Fujita N, Kageyama K, Ashida H, Kimura A, *et al.* The influence of the use of mupirocin nasal ointment on the incidence of endogenous MRSA infections in an intensive care unit. *Masui* 2000; **49**:867-71.
199. Hitomi S, Kubota M, Mori N, Baba S, Yano H, Okuzumi K, *et al.* Control of a methicillin-resistant *staphylococcus aureus* outbreak in a neonatal intensive care unit by unselective use of nasal mupirocin ointment. *J Hosp Infect* 2000; **46**:123-9.
200. Ibelings MM, Bruining HA. Methicillin-resistant *Staphylococcus aureus*: acquisition and risk of death in patients in the intensive care unit. *Eur J Surg* 1998; **164**:411-18.
201. Irish D, Eltringham I, Teall A, Pickett H, Farelly H, Reith S, *et al.* Control of an outbreak of an epidemic methicillin-resistant *Staphylococcus aureus* also resistant to mupirocin. *J Hosp Infect* 1998; **39**:19-26.
202. Jones JW, Carter A, Ewings P, O'Boyle PJ. An MRSA outbreak in a urology ward and its association with Nd:YAG coagulation laser treatment of the prostate. *J Hosp Infect* 1999; **41**:39-44.

203. Kahla Clemenceau CN, Barre E, Prat H, Thibault M, Bourret C, Richardin F, *et al.* Methicillin-resistant *Staphylococcus aureus* outbreak in a general hospital intensive care unit. *Pathol Biol* 1999; **47**:449–56.
204. King K, Brady L, Thomson M, Harkness JL. Antibiotic-resistant staphylococci in a teaching hospital. *Med J Aust* 1982; **2**:461–5.
205. Kouda M, Nakayama H, Hashimoto D, Haraguchi Y, Kazuura S, Utoh H, *et al.* Analysis of measure for prevention of nosocomial infection by MRSA in Tokyo Metropolitan Police Hospital. *Jpn Pharmacol Ther* 1992; **20**:295–305.
206. Kumari DN, Haji TC, Keer V, Hawkey PM, Duncanson V, Flower E. Ventilation grilles as a potential source of methicillin-resistant *Staphylococcus aureus* causing an outbreak in an orthopaedic ward at a district general hospital. *J Hosp Infect* 1998; **39**:127–33.
207. Kusachi S, Sumiyama Y, Nagao J, Kawai K, Arima Y, Yoshida Y, *et al.* New methods of control against postoperative methicillin-resistant *Staphylococcus aureus* infection. *Surg Today* 1999; **29**:724–9.
208. Lejeune B, Buzit-Losquin F, Simitzis-Le Flohic AM, Le Bras MP, Alix D. Outbreak of gentamicin-methicillin-resistant *Staphylococcus aureus* infection in an intensive care unit for children. *J Hosp Infect* 1986; **7**:21–5.
209. Lepelletier D, Regnier B, Richet H. Control of infections caused by multidrug resistant organisms in French hospitals. Example of methicillin-resistant *Staphylococcus aureus*. *Med Mal Infect* 1997; **27**:165–71.
210. Lessing MP, Jordens JZ, Bowler IC. When should healthcare workers be screened for methicillin-resistant *Staphylococcus aureus*? *J Hosp Infect* 1996; **34**:205–10.
211. Lingnau W, Allerberger F. Control of an outbreak of methicillin-resistant *Staphylococcus aureus* (MRSA) by hygienic measures in a general intensive care unit. *Infection* 1994; **22** (Suppl 2): S135–9.
212. Linnemann CC, Jr., Moore P, Staneck JL, Pfaller MA. Reemergence of epidemic methicillin-resistant *Staphylococcus aureus* in a general hospital associated with changing staphylococcal strains. *Am J Med* 1991; **91**(3B):238S–244S.
213. Liu CC, Hor LI, Wu YH, Huang AH, Lin CH, Chuang YC. Investigation and elimination of epidemic methicillin-resistant *Staphylococcus aureus* in a neonatal intensive care unit. *Chung-Hua Min Kuo Hsiao Erh Ko i Hsueh Hui Tsa Chih* 1993; **34**:285–93.
214. Locksley RM, Cohen ML, Quinn TC, Tompkins LS, Coyle MB, Kirihara JM, Counts GW. Multiply antibiotic-resistant *Staphylococcus aureus*: introduction, transmission, and evolution of nosocomial infection. *Ann Intern Med* 1982; **97**:317–24.
215. Loulergue J, Audurier A, DeLarbre JM, De Gialluly C. Changes in microbial ecology and use of cloxacillin. *J Hosp Infect* 1994; **27**:275–83.
216. Maeder K, Ginunas VJ, Montgomerie JZ, Canawati HN. Methicillin-resistant *Staphylococcus aureus* (MRSA) colonization in patients with spinal cord injury *Paraplegia* 1993; **31**:639–44.
217. Maguire GP, Arthur AD, Boustead PJ, Dwyer B, Currie BJ. Emerging epidemic of community-acquired methicillin-resistant *Staphylococcus aureus* infection in the Northern Territory. *Med J Australia* 1996; **164**:721–3.
218. Matsumura H, Yoshizawa N, Narumi A, Harunari N, Sugamata A, Watanabe, *et al.* Effective control of methicillin-resistant *Staphylococcus aureus* in a burn unit. *Burns* 1996; **22**:283–6.
219. Mehtar S, Drabu YJ, Mayet F. Expenses incurred during a 5-week epidemic methicillin-resistant *Staphylococcus aureus* outbreak. *J Hosp Infect* 1989; **13**:199–200.
220. Mehtar S. The continuing problem of 'hospital staphylococci': Why? *J Chemother* 1994; **6** (Suppl 4): 25–31.
221. Mehtar S. Infection control programmes: are they cost-effective? *J Hosp Infect* 1995; **30** (Suppl.):26–34.
222. Melo Cristino JA, Pereira AT, Afonso F, Naidoo JN. Methicillin-resistant *Staphylococcus aureus*: a 6-month survey in a Lisbon paediatric hospital. *J Hyg* 1986; **97**:265–72.
223. Meier PA, Carter CD, Wallace SE, Hollis RJ, Pfaller MA, Herwaldt LA. A prolonged outbreak of methicillin-resistant *Staphylococcus aureus* in the burn unit of a tertiary medical center. *Infect Control Hosp Epidemiol* 1996; **17**:798–802.
224. Michault A, Simac C. Hospital antibiotic resistance from 1993 to 1997 in Reunion. *Med Mal Infect* 1999; **29**:451–61.
225. Michel MF, Priem CC. Control at hospital level of infections by methicillin-resistant staphylococci in children. *J Hyg* 1971; **69**:453–60.
226. Millar MR, Keyworth N, Lincoln C, King B, Congdon P. 'Methicillin-resistant' *Staphylococcus aureus* in a regional neonatology unit. *J Hosp Infect* 1987; **10**:187–97.
227. Miller MA, Dascal A, Portnoy J, Mendelson J. Development of mupirocin resistance among methicillin-resistant *Staphylococcus aureus* after widespread use of nasal mupirocin ointment. *Infect Control Hosp Epidemiol* 1996; **17**:811–13.
228. Mochizuki H, Sugiyama M. Prevention and treatment of MRSA infection in emergency surgical ward. *Nippon Geka Gakkai Zasshi* 1992; **93**:902–5.

229. Moore EP, Williams EW. A maternity hospital outbreak of methicillin-resistant *Staphylococcus aureus*. *J Hosp Infect* 1991;**19**:5–16.
230. Morgan MG, Harte-Barry MJ. Methicillin-resistant *Staphylococcus aureus*: a ten-year survey in a Dublin hospital. *J Hosp Infect* 1989;**14**:357–62.
231. Morrison L, Stolarek I. Does MRSA affect patient outcomes in the elderly? A retrospective pilot study. *J Hosp Infect* 2000;**45**:169–71.
232. Mulhern B, Griffin E. An epidemic of gentamicin/cloxacillin resistant staphylococcal infection in a neonatal unit. *Ir Med J* 1981;**74**:228–9.
233. Murphy S, Denman S, Bennett RG, Greenough WB III, Lindsay J, Zelesnick LB. Methicillin-resistant *Staphylococcus aureus* colonization in a long-term-care facility. *J Am Geriatr Soc* 1992;**40**:213–17.
234. Nettleman MD, Trilla A, Fredrickson M, Pfaller M. Assigning responsibility: using feedback to achieve sustained control of methicillin-resistant *Staphylococcus aureus*. *Am J Med* 1991;**91**(3B): 228S–232S.
235. Netto dos Santos KR, de Souza FL, Gontijo Filho PP. Emergence of high-level mupirocin resistance in methicillin-resistant *Staphylococcus aureus* isolated from Brazilian university hospitals. *Infect Control Hosp Epidemiol* 1996;**17**:813–16.
236. Ng SP, Gomez JM, Lim SH, Ho NK. Reduction of nosocomial infection in a neonatal intensive care unit (NICU). *Singapore Med J* 1998;**39**:319–23.
237. Nicolle LE, Dyck B, Thompson G, Roman S, Kabani A, Plourde P, *et al.* Regional dissemination and control of epidemic methicillin-resistant *Staphylococcus aureus*. Manitoba Chapter of CHICA – Canada. *Infect Control Hosp Epidemiol* 1999;**20**:202–5.
238. Nørregaard C, Jensen I, Olesen J, Hagedorn S. Spread and control of methicillin resistant *Staphylococcus aureus* in a department of dermatology. *Ugeskr Laeger* 1998;**160**:2257–60.
239. Okano M, Noguchi S, Tabata K, Matsumoto Y. Topical gentian violet for cutaneous infection and nasal carriage with MRSA. *Int J Dermatol* 2000;**39**:942–4.
240. Olona CM, Tico FN, Ramirez GL, Del Valle OO, Castello VT, Garcia FL. Methicillin-resistant *Staphylococcus aureus*: a four-year experience in a spinal cord injury unit in Spain. *Spinal Cord* 1996;**34**:315–19.
241. Osono E, Takahashi M, Kurihara S, Ohwada K, Sakurai Y, Onoda N, *et al.* Effects of 'isolating hemodialysis' on prevention of methicillin-resistant *Staphylococcus aureus* cross-infection in a hemodialysis unit. *Clin Nephrol* 2000;**54**:128–33.
242. Park C, Pearce J. A major outbreak of methicillin resistant *Staphylococcus aureus* among patients and staff at Johannesburg Hospital during 1986–1987. *Nurs RSA* 1989;**4**:37–9.
243. Peacock JE, Wenzel RP. Methicillin resistant *Staph. aureus* (MRSA): introduction and spread within a hospital. *Clin Res* 1979;**27**:787A.
244. Pick FCM, Rose M, Wang D, Gardner BP, Gillett AP. The prevention of spread of methicillin resistant *Staphylococcus aureus* in a spinal injuries centre. *Paraplegia* 1994;**32**:732–5.
245. Prieto J, Clark J. Infection control. Dazed and confused. *Nurs Times* 1999;**95**(28):49–50.
246. Rahman M. Epidemic methicillin-resistant *Staphylococcus aureus* (EMRSA): experience from a health district of central England over five years. *Postgrad Med J* 1993;**69** Suppl 3:S126–9.
247. Rahman M, Sanderson PJ, Bentley AH, Barrett SP, Karim QN, Teare EL, *et al.* Control of MRSA. *J Hosp Infect* 2000;**44**:151–3.
248. Reardon CM, Brown TP, Stephenson AJ, Freedlander E. Methicillin-resistant *Staphylococcus aureus* in burns patients – why all the fuss? *Burns* 1998;**24**:393–7.
249. Reboli AC, John JF Jr, Levkoff AH. Epidemic methicillin–gentamicin-resistant *Staphylococcus aureus* in a neonatal intensive care unit. *Am J Dis Child* 1989;**143**:34–9.
250. Reboli AC, John JF Jr, Platt CG, Cantey JR. Methicillin-resistant *Staphylococcus aureus* outbreak at a Veterans' Affairs Medical Center: importance of carriage of the organism by hospital personnel. *Infect Control Hosp Epidemiol* 1990;**11**:291–6.
251. Ransjö U, Malm M, Hambræus A, Artursson G, Hedlund A. Methicillin-resistant *Staphylococcus aureus* in two burn units: clinical significance and epidemiological control. *J Hosp Infect* 1989;**13**:355–65.
252. Rhinehart E, Shlaes DM, Keys TF, Serkey J, Kirkley B, Kim C, *et al.* Nosocomial clonal dissemination of methicillin-resistant *Staphylococcus aureus*. Elucidation by plasmid analysis. *Arch Intern Med* 1987;**147**:521–4.
253. Ribner BS, Landry MN, Kidd K, Peninger M, Riddick J. Outbreak of multiply resistant *Staphylococcus aureus* in a pediatric intensive care unit after consolidation with a surgical intensive care unit. *Am J Infect Control* 1989;**17**:244–9.
254. Ridley M, Lynn R, Barrie D, Stead KC. Antibiotic-resistant *Staphylococcus aureus* and hospital antibiotic policies. *Lancet* 1970;**i**:230–3.
255. Roberts RB, Tennenberg AM, Eisner W, Hargrave J, Drusin LM, Yurt R, *et al.* Outbreak in a New York City teaching hospital burn center caused by the Iberian epidemic clone of MRSA. *Microb Drug Resist* 1998;**4**:175–83.

256. Rodriguez G, Gaspar MC, Mariano A, Fernandez C, Sanchez P, Fereres J. Management of an outbreak of methicillin-resistant *Staphylococcus aureus* in a risk area with empirical intranasal mupirocin. *J Hosp Infect* 1997;**36**:155–7.
257. Roman RS, Smith J, Walker M, Byrne S, Ramotar K, Dyck B, *et al.* Rapid geographic spread of a methicillin-resistant *Staphylococcus aureus* strain. *Clin Infect Dis* 1997;**25**:698–705.
258. Romance L, Nicolle L, Ross J, Law B. An outbreak of methicillin-resistant *Staphylococcus aureus* in a pediatric hospital – how it got away and how we caught it. *Can J Infect Control* 1991;**6**:11–13.
259. Rosenfeld CR, Laptook AR, Jeffery J. Limited effectiveness of triple dye in preventing colonization with methicillin-resistant *Staphylococcus aureus* in a special care nursery. *Pediatr Infect Dis J* 1990;**9**:290–1.
260. Rountree PM, Beard MA. Hospital strains of *Staphylococcus aureus*, with particular reference to methicillin-resistant strains. *Med J Aust* 1968;**2**:1163–8.
261. Ruchel R, Mergeryan H, Boger O, Langefeld C, Witte W. Outbreak of methicillin-resistant *Staphylococcus aureus* in a German tertiary-care hospital. *Infect Control Hosp Epidemiol* 1999;**20**:353–5.
262. Rumbak MJ, Cancio MR. Significant reduction in methicillin-resistant *Staphylococcus aureus* ventilator-associated pneumonia associated with the institution of a prevention protocol. *Crit Care Med* 1995;**23**:1200–3.
263. Sáez-Llorens X, Castrejon-De-Wong MM, Castano E, De Suman O, De Moros D, De Atencio I. Impact of an antibiotic restriction policy on hospital expenditures and bacterial susceptibilities: a lesson from a pediatric institution in a developing country. *Pediatr Infect Dis J* 2000;**19**:200–6.
264. Santos KR, Teixeira LM, Bravo Neto GP, Fonseca LS, Gontijo Filho PP. Mupirocin- and methicillin-resistant *Staphylococcus aureus* spreading in an intermediate-care unit in a Brazilian hospital. *Infect Control Hosp Epidemiol* 1998;**19**:622–3.
265. Saroglou G, Cromer M, Bisno AL. Methicillin-resistant *Staphylococcus aureus*: interstate spread of nosocomial infections with emergence of gentamicin–methicillin resistant strains. *Infect Control* 1980;**1**:81–9.
266. Saravolatz LD, Pohlod DJ, Arking LM. Community-acquired methicillin-resistant *Staphylococcus aureus* infections: a new source for nosocomial outbreaks. *Ann Intern Med* 1982;**97**:325–9.
267. Schmitz FJ, Verhoef J, Idel H, Hadding U, Heinz HP, Jones ME. Impact of hygienic measures on the development of methicillin resistance among staphylococci between 1991 and 1996 in a university hospital. *J Hosp Infect* 1998;**38**:237–40.
268. Schwarzkopf A, Karch H. A two-level isolation system for the defence against nosocomial infections with oxacillin-resistant *Staphylococcus aureus* and other multi-resistant pathogens. *Hyg Med* 1994;**19**:595–601.
269. Schweitzer M, Walther T, Juraske J, Osswald PM. Infection control measures in intensive-care-medicine. Efficacy of intranasal mupirocin in the prevention and therapy of an MRSA outbreak. *Intensivmed Notf med* 1997;**34**:778–89.
270. Scott GM, Thomson R, Malone-Lee J, Ridgway GL. Cross-infection between animals and man: possible feline transmission of *Staphylococcus aureus* infection in humans? *J Hosp Infect* 1988;**12**:29–34.
271. Scudeller L, Leoncini O, Boni S, Navarra A, Rezzani A, Verdirosi S, *et al.* MRSA carriage: the relationship between community and healthcare setting. A study in an Italian hospital. *J Hosp Infect* 2000;**46**:222–9.
272. Seipp HM, Stroh A. Multiresistant *Staphylococcus aureus* (MRSA) – significantly reduced incidence and rate in a tertiary care hospital, 1994 to 1999. *Hyg Med* 1999;**24**:224–37.
273. Sheridan RL, Weber J, Benjamin J, Pasternack MS, Tompkins RG. Control of methicillin-resistant *Staphylococcus aureus* in a pediatric burn unit. *Am J Infect Control* 1994;**22**:340–5.
274. Shimada M, Kamakura T, Itasaka H, Matsumata T, Hashizume M, Sugimachi K. The significance of methicillin-resistant *Staphylococcus aureus* infection in general surgery: a multivariate analysis of risk factors and preventive approaches. *Surg Today* 1993;**23**:880–4.
275. Sloot N, Walz G, Burzyk U, Fritsche D. Increased occurrence of MRSA outbreaks. *Kranenhr-Arzt* 1997;**4**:144–7.
276. Sloot N, Siebert J, Hoffler U. Eradication of MRSA from carriers by means of whole-body washing with an antiseptic in combination with mupirocin nasal ointment. *Zentralbl Hyg Umweltmed* 1999;**202**:513–23.
277. Smith NP, Nelson MR, Azadian B, Gazzard BG. An outbreak of methicillin-resistant *Staphylococcus aureus* (MRSA) infection in HIV-seropositive persons. *Int J STD AIDS* 1998;**9**:726–30.
278. Snyder LL, Wiebelhaus P, Boon SE, Morin RA, Goering R. Methicillin resistant *Staphylococcus aureus* eradication in a burn center. *J Burn Care Rehabil* 1993;**14** (2 II Suppl):164–8.
279. Pavillard R, Harvey K, Douglas D, Hewstone A, Andrew J, Collopy B, *et al.* Epidemic of hospital-acquired infection due to methicillin-resistant *Staphylococcus aureus* in major Victorian hospitals. *Med J Aust* 1982;**1**:451–4.

280. Spicer WJ. Three strategies in the control of staphylococci including methicillin-resistant *Staphylococcus aureus*. *J Hosp Infect* 1985;**5** Suppl A: 45–9.
281. Stover BH, Duff A, Adams G, Buck G, Hancock G, Rabalais G. Emergence and control of methicillin-resistant *Staphylococcus aureus* in a children's hospital and pediatric long-term care facility. *Am J Infect Control* 1992;**20**:248–55.
282. Stubbs S, Scott G, Gillbe C. Admission screening policy for MRSA: who needs it? Who does not? *J Cardiothorac Anesth* 1990;**4**(6 Suppl 3):65.
283. Suh K, Toye B, Jessamine P, Chan F, Ramotar K. Epidemiology of methicillin-resistant *Staphylococcus aureus* in three Canadian tertiary-care centers. *Infect Control Hosp Epidemiol* 1998;**19**:395–400.
284. Suh HK, Jeon YH, Song JS, Hwang SJ, Cheong HJ. A molecular epidemiologic study of methicillin-resistant *Staphylococcus aureus* infection in patients undergoing middle ear surgery. *Eur Arch Otorhinolaryngol* 1998;**255**:347–51.
285. Swanston WH. Methicillin resistant *Staphylococcus aureus*. *West Indian Med J* 1999;**48**:20–2.
286. Szromba C, Bowman-Riney S. Successful intervention in the reduction of methicillin resistant *Staphylococcus aureus* (MRSA) catheter related bacteremia. *ANNA Journal* 1992;**19**:153.
287. Takesue Y, Yokoyama T, Kodama T, Fujimoto M, Okita M, Sewake H, *et al.* Methicillin-resistant *Staphylococcus aureus* in nosocomial infections in the surgical ward and operating room. *Hiroshima J Med Sci* 1989;**38**:183–6.
288. Tambic A, Power EG, Talsania H, Anthony RM, French GL. Analysis of an outbreak of non-phage-typeable methicillin-resistant *Staphylococcus aureus* by using a randomly amplified polymorphic DNA assay. *J Clin Microbiol* 1997;**35**:3092–7.
289. Tan KW, Tay L, Lim SH. An outbreak of methicillin-resistant *Staphylococcus aureus* in a neonatal intensive care unit in Singapore: a 20-month study of clinical characteristics and control. *Singapore Med J* 1994;**35**:277–82.
290. Thom JD, Wolfe V, Perkash I, Lin VW. Methicillin-resistant *Staphylococcus aureus* in patients with spinal cord injury. *J Spinal Cord Med* 1999;**22**:125–31.
291. Tuffnell DJ, Croton RS, Hemingway DM, Hartley MN, Wake PN, Garvey RJ. Methicillin resistant *Staphylococcus aureus*; the role of antisepsis in the control of an outbreak *J Hosp Infect* 1987;**10**:255–9.
292. Turner GC, Cox PE. Resistance to cloxacillin among hospital staphylococci. *J Clin Pathol* 1967;**20**:870–4.
293. Tyzack R. The management of methicillin-resistant *Staphylococcus aureus* in a major hospital. *J Hosp Infect* 1985;**6** Suppl A:195–9.
294. Uetera Y, Matsumine T, Awane Y, Yamazaki E, Yokota T. Investigation of an outbreak of nosocomial infection due to methicillin-resistant *Staphylococcus aureus* (MRSA) in the surgical ward of Tokyo Metropolitan Fuchu Hospital. *J Infect Chemother* 1999;**5**:75–81.
295. Van Rijn RR, Kuijper EC, Kreis RW. Seven-year experience with a 'quarantine and isolation unit' for patients with burns. A retrospective analysis. *Burns* 1997;**23**:345–8.
296. Vandenbroucke-Grauls CM, Frenay HME, Van Klingeren B, Savelkoul TF, Verhoef J. Control of epidemic methicillin-resistant *Staphylococcus aureus* in a Dutch University Hospital. *Eur J Clin Microbiol Infect Dis* 1991;**10**:6–11.
297. Frenay HME, Vandenbroucke-Grauls CMJE, Savelkoul TJF, Rommes JH, Van Klingeren B, Verhoef J. Spread and control of a methicillin-resistant *Staphylococcus aureus* in a university hospital. *Ned Tijdschr Geneesk* 1990;**134**:1169–73.
298. Valls V, Gomez HP, Gonzalez PR, Cuadros JA, Romanyk JP, Ena J. Long-term efficacy of a program to control methicillin-resistant *Staphylococcus aureus*. *Eur J Clin Microbiol Infect Dis* 1994;**13**:90–5.
299. Vandenbroucke-Grauls CM. Methicillin-resistant *Staphylococcus aureus* control in hospitals: the Dutch experience. *Infect Control Hosp Epidemiol* 1996;**17**:512–13.
300. Walsh TJ, Vlahov D, Hansen SL, Sonnenberg E, Khabbaz R, Gadacz T, *et al.* Prospective microbiologic surveillance in control of nosocomial methicillin-resistant *Staphylococcus aureus*. *Infect Control* 1987;**8**:7–14.
301. Webster J, Faoagali JL. An in-use comparison of chlorhexidine gluconate 4% w/v, glycol-poly-siloxane plus methylcellulose and a liquid soap in a special care baby unit. *J Hosp Infect* 1989;**14**:141–51.
302. Webster J, Faoagali JL. Endemic methicillin-resistant *Staphylococcus aureus* in a special care baby unit: a 2 year review. *J Paediatr Child Health* 1990;**26**:160–3.
303. Webster J. Handwashing in a neonatal intensive care nursery: product acceptability and effectiveness of chlorhexidine gluconate 4% and triclosan 1%. *J Hosp Infect* 1992;**21**:137–41.
304. Webster J, Faoagali JL, Cartwright D. Elimination of methicillin-resistant *Staphylococcus aureus* from a neonatal intensive care unit after hand washing with triclosan. *J Paediatr Child Health* 1994;**30**:59–64.
305. Wilcox MH, Fitzgerald P, Freeman J, Denton M, Gill AB, Hoy C, *et al.* A five year outbreak of methicillin-susceptible *Staphylococcus aureus* phage type 53,85 in a regional neonatal unit. *Epidemiol Infect* 2000;**124**:37–45.

306. Wilson P, Dunn LJ. Using an MRSA isolation scoring system to decide whether patients should be nursed in isolation. *Hyg Med* 1996;**21**: 465–77.
307. Witte W, Braulke C, Heuck D, Cuny C. Analysis of nosocomial outbreaks with multiply and methicillin-resistant *Staphylococcus aureus* (MRSA) in Germany: implications for hospital hygiene. *Infection* 1994;**22** Suppl 2:S128–34.
308. Zafar AB, Butler RC, Reese DJ, Gaydos LA, Mennonona PA. Use of 0.3% triclosan (Bacti-Stat) to eradicate an outbreak of methicillin-resistant *Staphylococcus aureus* in a neonatal nursery. *Am J Infect Control* 1995;**23**:200–8.
309. Center for Disease Control. Outline for surveillance and control of nosocomial infection. Atlanta, GA: Center for Disease Control; 1976.
310. Cruse PJ, Foord R. The epidemiology of wound infection. A 10-year prospective study of 62,939 wounds. *Surg Clin North Am* 1980;**60**:27–40.
311. Garner JS, Jarvis WR, Emori TG, Horan TC, Hughes JM. CDC definitions for nosocomial infections. *Am J Infect Control* 1988;**16**:128–40.
312. Werkgroep Infectie Preventie. Management policy for methicillin-resistant *Staphylococcus aureus*. Guideline No. 35A. Leiden: WIP; 1994.
313. Steering Group of the Second National Prevalence Survey. National prevalence survey of hospital acquired infections: definitions. A preliminary report of the Steering Group of the Second National Prevalence Survey. *J Hosp Infect* 1993;**24**:69–76.
314. Center for Disease Control. Guidelines for isolation precautions in hospital. *Infect Control* 1983;**4** (Suppl):245–325.
315. Dixon RE, Brachman PS, Bennett JV. Isolation techniques for use in hospitals. 2nd ed. Atlanta, GA: Government Printing Office, Centers for Disease Control; 1975.
316. Garner JS, Bennett JV, Schenkler WE. Surveillance of nosocomial infections. In Proceedings of the International Conference on Nosocomial Infections. Centers for Disease Control, Chicago, 1970. Chicago, IL: American Hospital Association; 1971. pp. 277–81.
317. Lynch P, Jackson MM, Cummings MJ, Stamm WE. Rethinking the role of isolation practices in the prevention of nosocomial infections. *Ann Intern Med* 1987;**107**:243–6.
318. Health Commission Victoria. Staphylococcal infections in hospitals. 2nd ed. Health Commission Victoria, Australia; 1981.
319. Renshaw R. Modelling biological populations in space and time. Cambridge studies in mathematical biology. Cambridge: Cambridge University Press; 1993.
320. Cookson BD. Nosocomial antimicrobial resistance surveillance. *J Hosp Infect* 1999;**43**:S97–103.

Appendix I

Search strategy

MEDLINE (OVID Version 3.01) 1966–2001

1. exp staphylococcal infections/
2. (staphylococc\$ ADJ2 infect\$).tw.
3. staphylococcus aureus
4. (staphylococc\$ ADJ2 aureus).tw.
5. or/1-4
6. methicillin resistance/
7. (methicillin\$ ADJ2 resistan\$).tw.
8. penicillin resistance/
9. (pencillin ADJ2 resistan\$).tw.
10. (oxacillin ADJ2 resistan\$).tw.
11. or/6-10
12. 5 and 11
13. mrsa.tw.
14. emrsa.tw.
15. 13 or 14
16. 12 or 15
17. communicable disease control/
18. (communicable ADJ2 disease\$ ADJ2 control\$).tw.
19. handwashing/
20. handwash\$.tw.
21. (wash\$ ADJ2 hand\$).tw.
22. infection control/
23. (infect\$ ADJ2 control\$).tw.
24. patient isolation
25. (patient\$ ADJ2 isolation).tw.
26. (patient\$ ADJ2 isolated).tw.
27. (isolation ADJ2 unit\$).tw.
28. (isolation ADJ2 nurs\$).tw.
29. cross infection/
30. (cross ADJ2 infect\$).tw.
31. (nosocomial ADJ2 infect\$).tw.
32. (hospital\$ ADJ2 infect\$).tw.
33. (ward ADJ2 closure\$).tw.
34. (cohort ADJ2 nurs\$).tw.
35. or/17-34
36. incidence/
37. inciden\$.tw.
38. prevalence/
39. prevalen\$.tw.
40. epidemic\$.tw.
41. endemic\$.tw.
42. colonis\$.tw.
43. coloniz\$.tw.
44. screen\$.tw.
45. surveillance.tw.
46. or/36-45

47. exp “costs and cost analysis”
48. cost\$.tw.
49. economics/
50. economi\$.tw.
51. economic value of life/
52. economics, hospital/
53. hospital costs/
54. economics, medical/
55. economics, nursing/
56. economics, pharmaceutical/
57. exp hospitals/
58. inpatients/
59. inpatient\$.tw.
60. hospital\$.tw.
61. or/47-60
62. 35 or 46 or 61
63. 16 and 62

EMBASE (SilverPlatter Version 3.01) 1980–2000

1. “STAPHYLOCOCCUS-INFECTION”/all subheadings
2. STAPHYLOCC*
3. INFECT*
4. STAPHYLOCC* near2 INFECT*
5. STAPHYLOCOCC*
6. INFECT*
7. STAPHYLOCOCC* near2 INFECT*
8. “STAPHYLOCOCCUS-AUREUS”/all subheadings
9. STAPHYLOCOCC*
10. AUREUS
11. STAPHYLOCOCC* near2 AUREUS
12. STAPHYLOCC*
13. AUREUS
14. STAPHYLOCC* near2 AUREUS
15. #1 or #4 or #7 or #8 or #11 or #14
16. “OXACILLIN”/ all subheadings
17. OXACILLIN
18. RESISTAN*
19. OXACILLIN near2 RESISTAN*
20. #17 or #19
21. #15 and #20
22. #15 and #19
23. “INFECTION-CONTROL”/ all subheadings
24. INFECTION
25. CONTROL*
26. INFECTION near2 CONTROL*

27. COMMUNICABLE
 28. DISEASE*
 29. CONTROL*
 30. COMMUNICABLE near2 DISEASE* near2 CONTROL*
 31. "HAND-WASHING"/all subheadings
 32. HANDWASH*
 33. HAND
 34. WASH*
 35. HAND near2 WASH*
 36. WASH*
 37. HAND*
 38. WASH* near2 HAND*
 39. explode "PATIENT-CARE"/all subheadings
 40. PATIENT*
 41. ISOLATED
 42. PATIENT* near2 ISOLATED
 43. PATIENT*
 44. ISOLATION
 45. PATIENT* near2 ISOLATION
 46. PATIENT*
 47. ISOLATING
 48. PATIENT* near2 ISOLATING
 49. ISOLATION
 50. UNIT*
 51. ISOLATION near2 UNIT*
 52. ISOLATION
 53. NURS*
 54. ISOLATION near2 NURS*
 55. "CROSS-INFECTION"/all subheadings
 56. CROSS
 57. INFECTION*
 58. CROSS near2 INFECTION*
 59. NOSOCOMIAL
 60. INFECT*
 61. NOSOCOMIAL near2 INFECT*
 62. "HOSPITAL-INFECTION"/all subheadings
 63. HOSPITAL
 64. INFECT*
 65. HOSPITAL near2 INFECT*
 66. WARD
 67. CLOSURE*
 68. WARD near2 CLOSURE*
 69. COHORT
 70. NURS*
 71. COHORT near2 NURS*
 72. #23 or #26 or #30 or #31 or #32 or #35 or #38 or #39 or #42 or #45 or #48 or #51 or #54 or #55 or #58 or #61 or #62 or #65 or #68 or #71
 73. explode "INCIDENCE"/all subheadings
 75. INCIDEN*
 76. explode "PREVALENCE"/all subheadings
 77. PREVALEN*
 78. EPIDEMIC*
 79. ENDEMIC*
 80. explode "EPIDEMIC"/all subheadings
 81. "ENDEMIC-DISEASE"/all subheadings

82. explode "BACTERIAL-COLONIZATION"/all subheadings
 83. COLONIS*
 55. COLONIZ*
 85. explode "SCREENING"/all subheadings
 86. SCREEN*
 87. SURVEILLAN*
 88. #73 or #74 or #75 or #76 or #77 or #78 or #79 or #80 or #81 or #82 or #83 or #55 or #85 or #86
 89. explode "ECONOMIC-ASPECT"/all subheadings
 90. explode "COST"/all subheadings
 91. ECONOMI*
 92. explode "HEALTH-ECONOMICS"/all subheadings
 93. explode "HOSPITAL-COST"/all subheadings
 94. HOSPITAL*
 95. explode "HOSPITAL-PATIENT"/all subheadings
 96. INPATIENT*
 97. #88 or #89 or #90 or #91 or #92 or #93 or #94 or #95
 98. MRSA
 99. EMRSA
 100. #72 or #87 or #96
 101. #16 or #19
 102. #99 and #100

SIGLE (SilverPlatter Version 3.01) 1980–May 2000

1. mrsa
 2. methicillin resistan* staphyloc* aureus
 3. methicillin-resistan* staphyloc* aureus
 4. emrsa
 5. 1 OR 2 OR 3 OR 4 OR 5
 6. nosocomial NEAR infection* hospital NEAR acquired NEAR infect*
 7. hospital NEAR acquired NEAR infect*

CINAHL (WinSpirs/SilverPlatter) 1982–May 2000

1. 606 "Staphylococcal-Infections"/all topical subheadings/all age subheadings
 2. 1454 staphyloc*
 3. 30621 infect*
 4. 1071 staphyloc* near infect*
 5. 358 "Staphylococcus-Aureus"/all topical subheadings/all age subheadings
 6. 1444 staphylococ*
 7. 961 aureus

8.	920	staphylococc* near aureus	60.	1323	closure*
9.	1316	#1 or #4 or #5 or #8	61.	8	ward near closure*
10.	368	"Methicillin-Resistance"/all topical subheadings/all age subheadings	62.	1243	closure
11.	610	methicillin*	63.	8742	ward*
12.	7064	resistan*	64.	12	closure near ward*
13.	600	methicillin* near resistan*	65.	3314	cohort
14.	37	oxacillin	66.	232467	nurs*
15.	7064	resistan*	67.	329	cohort near nurs*
16.	25	oxacillin near resistan*	68.	17315	#23 or #27 or #28 or #29 or #32 or #35 or #38 or #41 or #44 or #47 or #48 or #51 or #54 or #58 or #61 or #64 or #67
17.	607	#10 or #13 or #16	69.	48	quarantine
18.	562	#9 and #17	70.	17342	#68 or #69
19.	299	mrsa	71.	868	"Incidence"/all topical subheadings/all age subheadings
20.	12	emrsa*	72.	10961	incidence
21.	300	#19 or #20	73.	1182	"Prevalence"/all topical subheadings/all age subheadings
22.	617	#18 or #21	74.	11078	prevalen*
23.	5562	explode "Infection-Control"/all topical subheadings/all age subheadings	75.	1178	"Disease-Outbreaks"/all topical subheadings/all age subheadings
24.	1558	communicable	76.	2593	epidemic*
25.	71063	disease*	77.	454	endemic
26.	82931	control*	78.	165	colonis*
27.	561	communicable near disease* near control*	79.	1052	coloniz*
28.	613	"Handwashing"/all topical subheadings/all age subheadings	80.	13125	screen*
29.	861	handwash*	81.	1309	"Disease-Surveillance"/all topical subheadings/all age subheadings
30.	643	wash	82.	4823	surveillan*
31.	26898	hand*	83.	36002	#71 or #72 or #73 or #74 or #75 or #76 or #77 or #78 or #79 or #80 or #81 or #82
32.	124	wash near hand*	84.	9697	explode "Costs-and-Cost-Analysis"/all topical subheadings/all age subheadings
33.	30621	infect*	85.	27948	cost*
34.	82931	control*	86.	61557	explode "Economics"/all topical subheadings/all age subheadings
35.	11819	infect* near control*	87.	22585	economi*
36.	143138	patient*	88.	8573	explode "Hospitals"/all topical subheadings/all age subheadings
37.	2746	isolation	89.	22193	"Inpatients"/all topical subheadings/all age subheadings
38.	873	patient* near isolation	90.	25529	inpatient*
39.	143138	patient*	91.	88638	hospital*
40.	2340	isolated	92.	78	"Carrier-State"/all topical subheadings/all age subheadings
41.	579	patient* near isolated	93.	1258	carrier*
42.	2746	isolation	94.	78654	state*
43.	97290	unit*	95.	208	carrier* near state*
44.	144	isolation near unit*	96.	163379	#84 or #85 or #86 or #87 or #88 or #89 or #90 or #91 or #92 or #95
45.	2746	isolation	97.	186659	#68 or #83 or #96
46.	232467	nurs*	98.	17	#22 and #92
47.	354	isolation near nurs*	*99.	586	#22 and #97
48.	4010	explode "Cross-Infection"/all topical subheadings/all age subheadings	100.	569	#99 not #98
49.	15234	cross			
50.	30621	infect*			
51.	3785	cross near infect*			
52.	2168	nosocomial			
53.	30621	infect*			
54.	1790	nosocomial near infect*			
55.	88638	hospital*			
56.	9672	acquired			
57.	30621	infect*			
58.	567	hospital* near acquired near infect*			
59.	6642	ward			

Appendix 2

Table of excluded studies

The following papers were excluded after initial or full-article appraisal. Where the reason for exclusion is given as 'low priority', this means that the study was rejected at the initial article appraisal stage (see Chapter 3).

Study	Details	Reason for exclusion
Abramson and Sexton, 1999 ¹⁴⁶	Prospective pairwise-matched nested case-control study to determine attributable costs for nosocomial MRSA and MSSA primary bloodstream infections	No isolation policy mentioned, and no relevant MRSA-related outcomes
Adeyemi-Doro <i>et al.</i> , 1997 ¹⁴⁷	Retrospective review of MRSA in a university hospital	Low priority
Aihara <i>et al.</i> , 1993 ¹⁴⁸	Report of MRSA outbreak in a premature infant ward	Low priority
Allen <i>et al.</i> , 1994 ¹⁴⁹	Report of MRSA outbreak on a neonatal unit	Low priority
Ang and Lee, 1997 ¹⁵⁰	Retrospective study of infections in a burns unit, including MRSA	Low priority
Asensio <i>et al.</i> , 1996 ¹⁵¹	Case-control study to identify factors associated with MRSA acquisition. Cohort study to evaluate decolonisation efficacy	No relevant MRSA-related outcomes that can be used for assessing isolation policy
Aubry-Damon <i>et al.</i> , 1997 ¹⁵²	Retrospective review of MRSA trends in a teaching hospital	Low priority
Ayliffe <i>et al.</i> , 1979 ¹¹⁶	Report of changing MRSA prevalences in three Birmingham hospitals. One hospital had an IW	No relevant outcomes for hospital with IW. Low priority for other two hospitals
Bacon <i>et al.</i> , 1987 ¹⁵³	Report of MRSA outbreak at a Veterans Administration Medical Center	Low priority
Bailey <i>et al.</i> , 1999 ¹⁵⁴	Retrospective study of MRSA in a university hospital to assess the effectiveness of a control programme involving screening and eradication therapy	Low priority
Barrett <i>et al.</i> , 1968 ¹⁵⁵	MRSA outbreak report	Low priority
Barrett <i>et al.</i> , 1988 ¹⁵⁶	Retrospective report of MRSA spread in a general hospital	Low priority
Barrett, 1990 ¹⁵⁷	Report of MRSA outbreak on two orthopaedic wards	Low priority
Barrett <i>et al.</i> , 1993 ¹⁵⁸	Retrospective review of MRSA isolates over 6 years in three health districts	Low priority
Bartzokas 1985 ¹⁵⁹	Report of MRSA outbreak in a vascular surgery unit	Low priority
Beaujean <i>et al.</i> , 1999 ¹²⁸	Study of persistence of MRSA carriage after discharge	Not a report of an MRSA outbreak or endemic MRSA
Bitar <i>et al.</i> , 1987 ¹⁶⁰	Report of MRSA outbreak in a university hospital	Low priority
Bock <i>et al.</i> , 1982 ¹⁶¹	Hospital MRSA outbreak report	Low priority
Bouchard <i>et al.</i> , 1999 ¹⁶²	Retrospective analysis of the use of an isolation unit in a university hospital	No relevant outcomes
Boyce <i>et al.</i> , 1981 ¹⁶³	Report of MRSA outbreak at a university hospital	Low priority
Boyce <i>et al.</i> , 1983 ¹⁶⁴	Report of MRSA experience in a university hospital	Low priority
Boyce <i>et al.</i> , 1993 ¹⁶⁵	Report of MRSA outbreak in a university-affiliated hospital	Low priority
Bradley <i>et al.</i> , 1985 ¹⁶⁶	Report of experience of MRSA at a teaching hospital	Low priority

continued

Study	Details	Reason for exclusion
Brun Buisson <i>et al.</i> , 1994 ¹⁶⁷	Prospective before and after study in five ICUs to examine efficacy of mupirocin for the eradication of <i>S. aureus</i>	No isolation policy mentioned
Cafferkey <i>et al.</i> , 1985 ³⁹	Review of experience with MRSA in 8 Dublin hospitals, 1971–84	Low priority
Campins <i>et al.</i> , 1992 ¹⁶⁸	MRSA outbreak report on a neonatal unit	Low priority
Cohen <i>et al.</i> , 1991 ¹⁶⁹	Report of experience of MRSA at a university hospital (possibly including use of IW)	Isolation policy not clearly defined
Coovadia <i>et al.</i> , 1989 ¹⁷⁰	Report of MRSA outbreak in a newborn nursery, including use of NC	Timing of interventions not clear
Craven <i>et al.</i> , 1981 ¹⁷¹	Report of MRSA outbreak in a teaching hospital's surgical department	Low priority
Dacre <i>et al.</i> , 1986 ¹⁷²	Report of MRSA outbreak on a urology ward	Low priority
Dancer and Crawford, 1999 ¹⁷³	A 3-year audit of MRSA in a district general hospital and surrounding community	Low priority
Danchivijitr <i>et al.</i> , 1995 ¹⁷⁴	Report of MRSA outbreak in a burns unit	Low priority
Darouiche <i>et al.</i> , 1991 ¹⁷⁵	Report of MRSA control within a spinal cord unit	Low priority
Davies <i>et al.</i> , 1987 ¹⁷⁶	Report of MRSA outbreak in an SCBU	Low priority
Dickson and Czurylo, 1988 ¹⁷⁷	Report of management of an MRSA epidemic in an acute care facility including use of an IW	No relevant outcomes
Dunkle <i>et al.</i> , 1981 ¹⁷⁸	Report of control of MRSA in an intensive care nursery. Control measures included NC	Initial isolation policy not clearly defined
Dziekan <i>et al.</i> , 2000 ¹⁷⁹	Report of MRSA epidemic in a university hospital (including a case-control study). Isolation consisted of cohort nursing of infected patients	Low priority
Fang <i>et al.</i> , 1993 ¹⁸⁰	Report of MRSA outbreak in a university hospital	Low priority
Farrington <i>et al.</i> , 1990 ¹⁸¹	Report of MRSA outbreaks in an SCBU and a burns unit	Low priority
Fazal <i>et al.</i> , 1996 ¹⁸²	Retrospective study of MRSA in an acute care hospital, before and after discontinuation of an isolation policy	Low priority
Finkelstein <i>et al.</i> , 1989 ¹⁸³	Report of MRSA in tertiary care hospital	Low priority
Fitzpatrick <i>et al.</i> , 2000 ¹³¹	Report of experience with an MRSA isolation unit	No relevant MRSA-related outcomes
Forward <i>et al.</i> , 1997 ¹⁸⁴	Report of MRSA outbreak and cumulative yields from different surveillance sites	Low priority
Fukatsu <i>et al.</i> , 1997 ¹⁸⁵	Retrospective review of MRSA at a teaching hospital	Low priority
Geldner <i>et al.</i> , 1999 ¹⁸⁶	Cost analysis of MRSA infection in an ICU	No relevant MRSA-related outcomes
Gerken, 1983 ¹⁸⁷	Chart review of patients acquiring MRSA during a hospital outbreak	Low priority
Gilmore <i>et al.</i> , 1986 ¹⁸⁸	Prospective study of a procedure-oriented isolation system for the control of MRSA in an acute and rehabilitative medical centre	Results reported as combined colonisation and infection, but no information on screening
Goetz and Muder, 1992 ¹⁸⁹	Report of 4-years' experience of MRSA at a Veterans Affairs Medical Center	Low priority
Goetz <i>et al.</i> , 1992 ¹⁹⁰	Report of MRSA outbreak at a Veteran's Administration Medical Center	Low priority
Gonzalez <i>et al.</i> , 1996 ¹⁹¹	MRSA outbreak report	Low priority
Guiguet <i>et al.</i> , 1990 ¹⁹²	MRSA outbreak report in an ICU	Low priority
Haddad <i>et al.</i> , 1993 ¹⁹³	Report of MRSA outbreak in an NICU	Low priority
Haiduven-Griffiths, 1988 ¹⁹⁴	Report of MRSA outbreak on a surgical service	Low priority
Haley <i>et al.</i> , 1995 ¹⁹⁵	Retrospective report of the control of endemic MRSA in an NICU	Low priority
Hansen <i>et al.</i> , 2000 ¹⁹⁶	Retrospective report of MRSA prevalence in a group of refugees	Low priority
Hartstein <i>et al.</i> , 1995 ¹⁹⁷	Retrospective report of MRSA in a university hospital	Low priority

Study	Details	Reason for exclusion
Hiramatsu <i>et al.</i> , 2000 ¹⁹⁸	Evaluation of blanket mupirocin use in an ICU. Prospective study with historical controls	No isolation policy mentioned
Hitomi <i>et al.</i> , 2000 ¹⁹⁹	Report of MRSA outbreak in an NICU	Low priority
Ibelings and Bruining, 1998 ²⁰⁰	Point prevalence survey of MRSA in ICUs in 17 Western European countries	No isolation policy mentioned
Irish <i>et al.</i> , 1998 ²⁰¹	Report on an MRSA outbreak in a district general hospital	Low priority
Jernigan <i>et al.</i> , 1995 ¹²⁶	Retrospective review of MRSA in a university hospital	Low priority
Jones <i>et al.</i> , 1999 ²⁰²	Retrospective report of an MRSA outbreak report on a urology ward over 4 years	Low priority
Kahla Clemenceau <i>et al.</i> , 1999 ²⁰³	Report of an MRSA outbreak in an ICU	Low priority
King <i>et al.</i> , 1982 ²⁰⁴	Report of MRSA outbreak at a university hospital. Control included use of IW	No outcome data after opening of IW
Kouda <i>et al.</i> , 1992 ²⁰⁵	Retrospective study of MRSA control measures in a hospital	Low priority
Kumari <i>et al.</i> , 1998 ²⁰⁶	Outbreak report in an orthopaedic ward	Low priority
Kusachi <i>et al.</i> , 1999 ²⁰⁷	Review of post-operative MRSA infections in digestive tract surgery patients before and after a control policy	Low priority
Lejeune <i>et al.</i> , 1986 ²⁰⁸	Report of MRSA outbreak on an ICU for children	Low priority
Lepelletier <i>et al.</i> , 1997 ²⁰⁹	Survey of MRSA trends and control measures in a random selection of French hospitals	Insufficient data to relate control measures to changes in MRSA
Lessing <i>et al.</i> , 1996 ²¹⁰	Retrospective report of MRSA clusters in a teaching hospital	Low priority
Lingnau and Allerberger, 1994 ²¹¹	Retrospective study of an MRSA outbreak in an ICU	Low priority
Linnemann <i>et al.</i> , 1991 ²¹²	Review of MRSA experience at a university hospital	Low priority
Liu <i>et al.</i> , 1993 ²¹³	Report of MRSA outbreak in an NICU	Low priority
Locksley <i>et al.</i> , 1982 ²¹⁴	Report of MRSA outbreak in a teaching hospital	Low priority
Loulergue <i>et al.</i> , 1994 ²¹⁵	Review of MRSA experience over 15 years at a university hospital	Low priority
Maeder <i>et al.</i> , 1993 ²¹⁶	Review of 2 years' experience of a protocol to prevent MRSA spread among spinal cord injured patients	Low priority
Maguire <i>et al.</i> , 1996 ²¹⁷	Retrospective report of MRSA infections at a tertiary referral hospital	Low priority
Matsumura <i>et al.</i> , 1996 ²¹⁸	Retrospective study of MRSA in a burns unit	Low priority
Meers and Leong, 1990 ¹³	Report of 4 years' experience of MRSA at a teaching hospital	Low priority
Mehtar <i>et al.</i> , 1989 ²¹⁹	Description and costing of MRSA outbreak on three surgical wards and now ICU	Low priority
Mehtar, 1994 ²²⁰	Review of MRSA experience at a general hospital	Low priority
Mehtar, 1995 ²²¹	Review of cost-effectiveness of infection control programmes	Not a report of an MRSA outbreak or endemic MRSA
Melo Cristino <i>et al.</i> , 1986 ²²²	Prospective non-comparative study of MRSA in a paediatric surgical unit	No isolation strategy mentioned
Meier <i>et al.</i> , 1996 ²²³	Report of MRSA outbreak in a burns unit	Low priority
Michault and Simac, 1999 ²²⁴	Retrospective report of changing antibiotic resistance patterns (including a reduction in MRSA) in a hospital over a 5-year period. No patient isolation throughout	Low priority
Michel and Priem, 1971 ²²⁵	Report of MRSA outbreak in a children's hospital	Low priority. (Additional information from author confirmed lack of IW)
Millar <i>et al.</i> , 1987 ²²⁶	MRSA outbreak report on a neonatal unit	Low priority
Miller <i>et al.</i> , 1996 ²²⁷	Retrospective report of MRSA in a teaching hospital	Low priority

Appendix 2 cont'd Table of excluded studies

Study	Details	Reason for exclusion
Mochizuki and Sugiyama, 1992 ²²⁸	Report of MRSA experience in an emergency surgical ward	Low priority
Moore and Williams, 1991 ²²⁹	Report of MRSA outbreak in a maternity hospital (including use of NC)	Isolation policy not clearly defined. No relevant outcomes (impossible to relate outcomes to control measures as timing not specified)
Morgan and Harte-Barry, 1989 ²³⁰	Retrospective study of changes in MRSA over 10 years in a hospital	Low priority
Morrison and Stolarek, 2000 ²³¹	Retrospective study comparing outcomes among MRSA-positive and -negative patients	Low priority and no relevant outcomes
Mulhern and Griffin, 1981 ²³²	Report of MRSA outbreak in a neonatal unit	Low priority
Murphy <i>et al.</i> , 1992 ²³³	Study of MRSA at a long-term care facility	Not a hospital setting
Nettleman <i>et al.</i> , 1991 ²³⁴	Evaluation of handwashing education and feedback programme for control of MRSA	Low priority
Netto dos Santos <i>et al.</i> , 1996 ²³⁵	Prospective study of mupirocin resistance in two university hospitals	No isolation policy mentioned
Ng <i>et al.</i> , 1998 ²³⁶	2-year retrospective evaluation of impact of a nosocomial infection control programme in an NICU	Low priority
Nicolle <i>et al.</i> , 1999 ²³⁷	Retrospective report of 6 years of MRSA at a tertiary hospital, with secondary outbreaks at other hospitals. Isolation changed from unspecified to cohorting	Low priority
Nørregaard <i>et al.</i> , 1998 ²³⁸	Report of MRSA outbreak in a dermatology department	Low priority
Okano <i>et al.</i> , 2000 ²³⁹	Study of use of topical gentian violet for MRSA eradication	No relevant MRSA-related outcomes
Olona <i>et al.</i> , 1996 ²⁴⁰	Retrospective report of MRSA over four years in a spinal cord injury unit	Low priority
Osono <i>et al.</i> , 2000 ²⁴¹	Retrospective evaluation of a contact isolation programme to prevent MRSA cross-infection on a haemodialysis unit	Low priority
Park and Pearce, 1989 ²⁴²	Report of MRSA outbreak, including use of IW	Isolation policy and timing of interventions unclear
Peacock and Wenzel, 1979 ²⁴³	Short outbreak report	Low priority
Pick <i>et al.</i> , 1994 ²⁴⁴	Report of MRSA experience over 4 years in a spinal injury centre	Low priority
Prieto and Clark, 1999 ²⁴⁵	Preliminary finding from observational study to assess implementation of isolation precautions for patients with MRSA and <i>Clostridium difficile</i> -associated diarrhoea	No relevant MRSA-related outcomes
Rahman, 1993 ²⁴⁶	Retrospective report of MRSA outbreaks in three hospitals. Control measures included an IW	No relevant outcomes (outcomes cannot be related to interventions)
Rahman <i>et al.</i> , 2000 ²⁴⁷	MRSA outbreak report at a teaching hospital	Low priority
Reardon <i>et al.</i> , 1998 ²⁴⁸	Retrospective review of MRSA colonisation over 41 months in a burns unit	Low priority
Reboli <i>et al.</i> , 1989 ²⁴⁹	Report of MRSA outbreak in an NICU, including use of NC	Isolation policy not clearly defined
Reboli <i>et al.</i> , 1990 ²⁵⁰	Report of MRSA experience at a Veterans' Affairs Medical Center, possibly including use of an isolation unit	Isolation policy not clearly defined
Ransjö <i>et al.</i> , 1989 ²⁵¹	Report of MRSA outbreaks on two burns units	Low priority
Rhinehart <i>et al.</i> , 1987 ²⁵²	Report of MRSA outbreak in a tertiary care centre	Low priority
Ribner <i>et al.</i> , 1989 ²⁵³	MRSA outbreak report on a PICU	Low priority

Study	Details	Reason for exclusion
Richet <i>et al.</i> , 1996 ¹³⁴	Survey of MRSA and control measures in 27 hospitals	Insufficient data to relate changes in MRSA to control measures
Ridley <i>et al.</i> , 1970 ²⁵⁴	Retrospective review of antibiotic-resistant <i>S. aureus</i> and antibiotic usage in a teaching hospital. Includes 5 years' MRSA data	Low priority
Roberts <i>et al.</i> , 1998 ²⁵⁵	Report of MRSA outbreak in a burn centre. Control measures included NC	Isolation policy and changes to it unclear
Rodríguez <i>et al.</i> , 1997 ²⁵⁶	Report of MRSA outbreak in a teaching hospital	Low priority
Roman <i>et al.</i> , 1997 ²⁵⁷	MRSA outbreak report at three tertiary care centres	Low priority
Romance <i>et al.</i> , 1991 ²⁵⁸	MRSA outbreak report in a children's hospital	Low priority
Rosenfeld <i>et al.</i> , 1990 ²⁵⁹	Quasi-randomised trial of the use of triple die for preventing MRSA colonisation in a special care nursery. No change to patient isolation (cohorting throughout)	No relevant ward-level outcomes
Rountree and Beard, 1968 ²⁶⁰	4-year retrospective study of antibiotic-resistant staphylococci (including MRSA) in a teaching hospital	Low priority
Ruchel <i>et al.</i> , 1999 ²⁶¹	Retrospective report of MRSA outbreak in ICUs of a tertiary hospital. Cohorting and side-room isolation used	Low priority
Rumbak and Cancio, 1995 ²⁶²	Retrospective chart review to determine effect of an MRSA control programme in a university-affiliated long-term acute care ventilator hospital	Low priority
Sáez-Llorens <i>et al.</i> , 2000 ²⁶³	Retrospective study of impact of an antibiotic-restriction policy on bacterial antibiotic resistance (including MRSA)	No isolation policy mentioned
Santos <i>et al.</i> , 1998 ²⁶⁴	Retrospective survey of MRSA in a university hospital	Low priority
Saroglou <i>et al.</i> , 1980 ²⁶⁵	Report of MRSA outbreak in a general hospital	Low priority
Saravolatz <i>et al.</i> , 1982 ²⁶⁶	Retrospective report of MRSA experience at a university hospital	Low priority
Schmitz <i>et al.</i> , 1997 ¹³⁷	Review of MRSA in 11 Düsseldorf hospitals	No relevant outcomes (no data relating outcomes to control measures)
Schmitz <i>et al.</i> , 1998 ²⁶⁷	Retrospective review of changing MRSA prevalence in a university hospital	Low priority
Schwarzkopf and Karch, 1994 ²⁶⁸	Report of clinical experience of an isolation system for patients with MRSA	Low priority
Schweitzer <i>et al.</i> , 1997 ²⁶⁹	Retrospective study of MRSA in an ICU	Low priority
Scott <i>et al.</i> , 1988 ²⁷⁰	Report of MRSA outbreak on a geriatric rehabilitation ward	Low priority
Scudeller <i>et al.</i> , 2000 ²⁷¹	Report of patient MRSA carriage on admission to an acute care and rehabilitation centre	Low priority
Seipp and Stroh, 1999 ²⁷²	Retrospective report of impact of an infection control programme on MRSA in a tertiary hospital	Low priority
Sheridan <i>et al.</i> , 1994 ²⁷³	Review of MRSA over 7 years in a paediatric burns unit	Low priority
Shimada <i>et al.</i> , 1993 ²⁷⁴	Report of 5 years' experience of MRSA in a surgery department	Low priority
Sloot <i>et al.</i> , 1997 ²⁷⁵	Hospital MRSA outbreak report	Low priority
Sloot <i>et al.</i> , 1999 ²⁷⁶	MRSA eradication study	No relevant outcomes
Smith <i>et al.</i> , 1998 ²⁷⁷	Retrospective case series of an outbreak of MRSA infection on an HIV ward. Side-room isolation used for control	Low priority
Snyder <i>et al.</i> , 1993 ²⁷⁸	Report of MRSA outbreak in a burns centre	Low priority
Spicer, 1985 ^{279,280}	Report of three control strategies for MRSA in a teaching hospital. Includes use of IW	Isolation policy, screening policy, and timing of phases not clear
Stover <i>et al.</i> , 1992 ²⁸¹	MRSA outbreak report in a children's hospital and a paediatric long-term care facility	Low priority

Appendix 2 cont'd Table of excluded studies

Study	Details	Reason for exclusion
Struelens <i>et al.</i> , 1996 ¹³⁶	Report of control measures and MRSA incidence in Belgian hospitals	Not possible to relate control measures to outcomes
Stubbs <i>et al.</i> , 1990 ²⁸²	Admission survey of MRSA carriage in a private hospital	Not an MRSA outbreak or endemic MRSA. No isolation policy described
Suh <i>et al.</i> , 1998 ²⁸³	Retrospective review of MRSA in three teaching hospitals	Low priority
Suh <i>et al.</i> , 1998 ²⁸⁴	Retrospective study of MRSA infections following middle ear surgery. Interventions included handwashing, and topical eradication from carers	Low priority
Swanston, 1999 ²⁸⁵	Non-comparative retrospective report of 1 years' experience of MRSA in a general hospital	Low priority
Szromba and Bowman-Riney, 1992 ²⁸⁶	Retrospective report of MRSA bacteraemias in patients on maintenance haemodialysis. Interventions included geographical separation of patients	Low priority
Takesue <i>et al.</i> , 1989 ²⁸⁷	Report of 6 years' experience of MRSA in a surgical ward and operating room	Low priority
Tambic <i>et al.</i> , 1997 ²⁸⁸	MRSA outbreak report on an ICU	Low priority
Tan <i>et al.</i> , 1994 ²⁸⁹	Report of MRSA outbreak in an NICU. Control measures including NC	Timing of interventions not clearly defined with respect to outcome data
Thom <i>et al.</i> , 1999 ²⁹⁰	Retrospective chart review of MRSA-positive cases over 5 years in a population with spinal cord injury	Low priority
Thompson <i>et al.</i> , 1982 ¹¹	Report of MRSA control in a university hospital	Low priority
Trilla <i>et al.</i> , 1996 ¹³⁵	Survey of MRSA control measures and MRSA prevalences in 24 hospitals in and around Barcelona	No relevant outcomes (no data relating outcomes to control measures)
Tuffnell <i>et al.</i> , 1987 ²⁹¹	Report of MRSA outbreak in a general hospital, including use of an IW	Isolation policy not clearly defined
Turner and Cox, 1967 ²⁹²	Retrospective report of MRSA at a general hospital, including use of an IW	Isolation policy not clearly defined
Tyzack, 1985 ²⁹³	Report of the effect of a control programme (including use of an IW) on MRSA in a general hospital	Initial isolation policy not clearly defined
Uehara <i>et al.</i> , 2000 ⁶²	Study of eradication of <i>S. aureus</i> (including MRSA) by bacterial interference	No relevant MRSA-related outcomes
Uetera <i>et al.</i> , 1999 ²⁹⁴	Retrospective evaluation of the effect of an infection control practitioner on MRSA infections in a surgical ward	Low priority
van Rijn <i>et al.</i> , 1997 ²⁹⁵	Retrospective study of effectiveness of a quarantine and isolation unit for the control multi-resistant microorganisms	No endemic MRSA or MRSA outbreak
Vandenbroucke-Grauls <i>et al.</i> , 1991 ²⁹⁶	Retrospective report of three MRSA outbreaks in a teaching hospital. Changes to screening and isolation, including use of an IW	Isolation and timing of interventions not clearly defined
Frenay <i>et al.</i> , 1990 ²⁹⁷		
Valls <i>et al.</i> , 1994 ²⁹⁸	Retrospective evaluation of a control programme in a university hospital	Low priority
Vandenbroucke-Grauls, 1996 ²⁹⁹	Review of 6 years of MRSA surveillance in The Netherlands	Low priority
Walsh <i>et al.</i> , 1987 ³⁰⁰	Report of MRSA outbreak in acute care hospital. IW used	Initial isolation policy not clearly defined
Ward <i>et al.</i> , 1981 ¹⁰⁰	Report of two MRSA outbreaks in two general hospitals (University of Oregon Health Services Centre and Portland Veterans' Administration Medical Centre). The latter used an IW and is included in the review. Only the former was low priority	Low priority (for UOSC outbreak)
Webster and Faoagali, 1989 ³⁰¹	Study of effectiveness of three handwash agents for preventing MRSA transmission in an SCBU	No isolation policy mentioned

Study	Details	Reason for exclusion
Webster and Faoagali, 1990 ³⁰²	Retrospective study of endemic MRSA in an SCBU	Low priority
Webster, 1992 ³⁰³	Cohort study comparing the effectiveness of triclosan and chlorhexidine against MRSA	No isolation policy mentioned
Webster <i>et al.</i> , 1994 ³⁰⁴	Study of impact of triclosan use on MRSA in an NICU	No isolation policy mentioned
Wilcox <i>et al.</i> , 2000 ³⁰⁵	Retrospective study of a 5-year outbreak of MRSA in a neonatal unit	Low priority
Wilson and Dunn, 1996 ³⁰⁶	Report of a scoring system to decide whether MRSA patients should be nursed in isolation	Low priority
Witte <i>et al.</i> , 1994 ³⁰⁷	Report of MRSA outbreaks in a urological unit and an orthopaedic clinic	Low priority
Zafar <i>et al.</i> , 1995 ³⁰⁸	Report of MRSA outbreak in a neonatal unit	Low priority

SCBU, special care baby unit; NICU, neonatal intensive care unit; PICU, paediatric intensive care unit.

Appendix 3

Full summary tables of data extraction for accepted studies



Study: Alvarez *et al.*, 1985⁹⁹ **Design:** Retrospective outbreak report (uninterrupted time series)
Setting: Teaching hospital **Location:** Tennessee, USA **Dates:** September 1983–April 1984
Population characteristics: 570 beds. Mean daily census: 414 patients. Outbreak based in ICU and 2 general surgical wards only. Mean age: 59.7 (to November 1983). Mean LOS on surgical service: 19.5 days (for 1982). Mean (SD) LOS for MRSA-positive patients: 85.7 (43.5) days (1983 figure). MRSA not endemic. ICT
Stated aim of study: To report clinical features, epidemiological pattern and bacteriological data for an MRSA outbreak
Major infection control changes during the study: None

	Isolation	Screening	Eradication	Other measures
Phase I 8 months (9 Sept. 1983–Apr. 1984)	IW	HCW and patient contacts of MRSA patients	Eradication from colonised HCWs	1. Tried to identify readmitted MRSA patients 2. Handwashing education 3. CDC guidelines used for surveillance and isolation ³⁰⁹

Isolation details: IW not purpose-built, but a converted ward with 30–35 beds. No overflow. Wound and skin precautions for MRSA patients on IW with colonised/infected cutaneous wounds. Masks and side room on IW if lower respiratory tract (LRT) infections/colonisation³⁰⁹

Screening details: Screening sites: nose; throat; hands

Eradication details: Topical agents used: bacitracin and Phisohex baths. Clearance defined by repeated negative screens of previously positive sites

Reported outcomes:

1. Incidence:

Total MRSA: 11 colonised or infected patients during study

Infections: Time series of monthly MRSA infections. 8 MRSA-infected patients. 4 MRSA bacteraemias; 1 pneumonia

Colonisation: Time series of monthly MRSA colonisations reported. 4 colonised in total

MRSA carriage on admission: No data

Attributable death: 1

Definitions: Infections: CDC.³⁰⁹ *Attributable mortality:* directly related to MRSA with no other obvious cause

2. Point Prevalence: No data

3. Trends: All cases except one occurred in a cluster over a 3-month period (Sept.–Nov.). The last case occurred in Feb. 1985. Monthly MSSA isolates increased each month from June 1983, peaking in Nov. 1983. Subsequently, numbers fell each month to Apr. 1985

4. Secondary outcomes: (i) *monthly MSSA isolates:* Increased each month from June 1983, peaked in Nov. 1983 (at height of MRSA outbreak). Numbers then fell each month to Apr. 1985. MRSA:MSSA available

(ii) *HCW carriage:* 1 identified, from 198 screened individuals and 594 cultures

Economic evaluation: None

MRSA strain details: 10 isolates phage typed: 7 were 29/52/80/95/83A; 3 untypeable. Resistant to cefmandole, cefotaxime and erythromycin

Analysis in paper: None

Major cofounders and bias: Changes in the number of MSSA isolates suggest large changes in the screening intensity with time that mirrors the course of the outbreak. Large reporting bias likely with this type of report

What the authors conclude: Despite prompt instigation of isolation procedures and educational efforts, secondary spread was not prevented. Once all affected patients were isolated there was no further spread

Assessment of authors' conclusions: Conclusions consistent with data but a small outbreak, and stochastic effects likely to be dominant

Study: Arnow *et al.*, 1982⁷⁹ **Design:** Hybrid retrospective (phase 1), prospective (phase 2) ITS
Setting: Burns unit **Location:** USA **Dates:** 10 February 1975–30 June 1976
Population characteristics: 8 beds. Mean ages: 29 (colonised patients); 22 (uncolonised); 42 (infected). Endemic MRSA. 147 admissions between 10 Feb. and 30 Sept. 1975. Mean LOS: 6 days (uncolonised patients); 28 days (colonised patients); 33 days (infected patients). ICT^a
Stated aim of study: To investigate spread of MRSA on a burns unit and to examine the relationship between nurse staffing patterns and transmission of MRSA
Major infection control changes during the study: Patient isolation; screening; handwashing education

	Isolation	Screening	Eradication	Other measures
Phase 1 8.5 months (10 Feb.– 19 Oct. 1975)	Barrier precautions only	All HCWs screened in March, May and Sept. and selected HCWs in mid-Oct. Patients screened weekly	Eradication from all staff carriers	
Phase 2 8.5 months (20 Oct. 1975–30 June 1976)	NC	All patients and HCWs screened twice weekly	As phase 1	Handwashing education. Only non-colonised staff were assigned to work with non-colonised patients. Disinfection of hydrotherapy equipment

Isolation details: From mid-Nov. 1975 (phase 2) for 1.5 months NC was not possible on evening and night shifts owing to staff shortages

Screening details: Screening sites: nose (staff; patients in phase 2 and briefly in Oct. 1975^a); wounds (patients)

Eradication details: Topical agent: bacitracin.^a An ointment containing vancomycin was also used in phase 2^a

Reported outcomes:

1. Incidence:

Total MRSA: Time series of weekly incidence reported for whole study. Total number of patients with MRSA: 39 (phase 1); 6 (phase 2)

Number of patients with heavy MRSA growth (10 Feb.–30 Sept. 1975): 35 from 102 swabbed patients and 147 admissions

Infections and colonisations: Data from 10 Feb.–30 Sept. 1975 only: 28 colonised and 7 infected patients

Definitions: Infections: MRSA sole predominant pathogen with presence of fever and purulence

Carriage on admission: No data, but all strains of common outbreak type assumed to be acquired on unit

2. Point prevalence: No data

3. Trends: Before NC was instituted new cases had been detected in each of the previous 11 weeks and 22 of the last 37. MRSA appeared endemic. Subsequently there were no new cases for 4 weeks. When NC had to be relaxed in mid-Nov. new cases occurred in 5 of the next 7 weeks. After reinstating NC in Jan. no new cases were found for 6 months until the end of the study

4. Secondary outcomes: HCW carriage: 6 nasal carriers from 38 screened in phase 1 (on 14 Oct.)

Economic evaluation: None

MRSA strain details: All MRSA had same phage type (85) and antibiogram (resistant to erythromycin, tetracycline, streptomycin, sulphathiazole, penicillin, ampicillin, methicillin)

Analysis in paper: No analysis of time series data

Major confounders and bias: Very large changes in weekly patient days during study, and patient days shown to be correlated with per cent of susceptible patients colonised each week. Study design vulnerable to regression to the mean effects

What the authors conclude: 1. Establishment of NCs appeared to be essential for control of the outbreak
 2. Nurse staffing may have been an important factor in staphylococcal transmission

Assessment of authors' conclusions:

1. Transmission was interrupted and eliminated from the unit. Transmission appeared to be interrupted only during periods of NC although its necessity was not shown, and other control measures were introduced simultaneously

2. Correlations between incidence and temporary personnel, overtime hours and patient census are appealing but circumstantial and are consistent with a number of different explanations

Notes: This study also included a case-control study and circumstantial evidence suggesting that spread was primarily by contact transmission from staff and via equipment. Risk of infection was associated with extent of burns. These additional pieces of information have not been critically appraised here

^a Additional information obtained from authors.

Study: Back *et al.*, 1996¹¹³ **Design:** Retrospective ITS (4 phases)
Setting: NICU **Location:** Cincinnati, OH, USA **Dates:** 17 Feb. 1992–31 Dec. 1992
Population characteristics: Unit included a level 3 NICU and an SCBU. 50 beds. MRSA not endemic
Stated aim of study: To describe the MRSA epidemic in the NICU
Major infection control changes during the study: MRSA eradication, screening and ward closure

	Isolation	Screening	Eradication	Other measures
Phase 1 2 months (17 Feb.– 18 Apr. 1992)	NC on open bays + single-room isolation	No IMS (see Notes) Weekly patient screening from 1 March. Cohort staff screened when working outside cohort area	Mupirocin for colonised HCWs	Scrubsuits, gowns + masks
Phase 2 ~4 months (19 Apr.– mid-Aug.)	As above	As above + contacts of MRSA patients. All HCWs (once) IMS (see Notes)	On 3 May one-off mupirocin use: all infants + parents and HCW contacts of colonised infants	As above + wards closed to new admissions when new MRSA cases
Phase 3 ~2 months (mid-Aug.– 10 Oct. 1992)	As above	Contacts of newly identified MRSA patients No IMS	None	As phase 1
Phase 4 2.5 months (11 Oct.– 31 Dec. 1992)	As above	Weekly patient screening + contacts of MRSA patients IMS	None	As phase 2

Isolation details: Side-room isolation if only one MRSA patient.^a Nurses and respiratory therapists cohorted with MRSA infants, but sometimes did shifts outside cohort and were then required to wear masks. Cohort staff wore scrubsuits; gowns only when leaving cohort. Gowns + masks required for non-cohort staff treating MRSA patients. In phase 1 handwashing agent changed to chlorhexidine and handwashing compliance monitored

Screening details: Infant screening sites: nose, rectum (from mid-March 1992). HCWs had nasal screens only. Weekly screening stopped after all screens were negative for 4 weeks (early–mid-June)

Eradication details: As above.

Reported outcomes:

1. Incidence:

Total MRSA: Weekly incidence of colonised or infected infants reported throughout the study. 46 cases in total

Infections: 10 infants with MRSA described as having clinical disease

Denominators: None

MRSA mortality: Two attributable deaths reported

Colonisation: 45 infants described as being colonised with MRSA

Definitions: MRSA carriage on admission: not specified, but can assume that all (or nearly all) are acquisitions as patients are neonates and isolates were of the same strain type

Infections: unspecified 'pre-established criteria'

2. Point prevalence: No data, but there was at least one colonised infant on the ward at all times

3. Trends: Continuous presence of MRSA on ward throughout study, with two major clusters of cases: one lasting 12 weeks and affecting 30 infants (Feb.–May), the second lasting 5 weeks and affecting 14 infants. The first outbreak had a maximum of 9 new cases in one week (coinciding with the introduction of the screening programme in phase 1). Between 1 and 5 new cases were detected for the next 7 weeks. After the introduction of IMS and mupirocin therapy (phase 2) no new cases occurred for 2 months, although several colonised infants were present (and isolated). The second major outbreak occurred in late-Sept. No more than 4 cases were detected in any one week. New cases continued for 2 weeks after the introduction of IMS (phase 5) and then stopped

Economic evaluation: None

MRSA strain details: One predominant strain found and plasmid analysis suggested it was the same strain throughout. All isolates were resistant to gentamicin, clindamycin and erythromycin

Analysis in paper: No relevant analysis

Major confounders and bias: Reporting bias. Interpretation of time series severely compromised by changes in screening

continued

What the authors conclude:

1. Traditional interventions and weekly swabs were unsuccessful in ending the outbreak
2. The outbreak was successfully contained when IMS and mupirocin were used, but relative contributions can't be assessed
3. Immediate isolation and swabbing of contacts diminished transmission

Assessment of authors' conclusions:

1. Conclusion appears to be justified, as new cases continued to appear over an extended period in phase I. However insufficient data are presented to allow an assessment of the chance of a stochastic fadeout
2. Conclusion is justified by the data, and the temporal relationship is consistent with a causality
3. This is not contradicted by the data, and the persistence of colonised and isolated patients without much detectable transmission lends it plausibility, but without further prevalence data it cannot be assessed

All conclusions are further limited by the retrospective nature of the study and large reporting biases can be expected with this kind of report

Notes: Authors describe two 'epidemics', but since there appears to be a continuous chain of transmission it is considered to be one here. Phases correspond to periods when the IMS protocol was in operation. IMS corresponds to weekly swabbing of infants starting whenever one new case is found, immediate reculturing of contacts of positive infants, continuation of weekly cultures for 4 weeks after the last case is found and closure of affected sections of the ward until no new cases are found. During the July outbreak IMS was instituted immediately when a new case was found, and the IMS protocol is therefore assumed to be in operation continuously from its inception (19 April) until this time. IMS was introduced only 2 weeks after the Sept. outbreak; the protocol is therefore assumed not to be in operation from the time weekly screening ended after the July outbreak

IMS, intensive microbiological surveillance.

^a Additional information obtained from authors.

Study: Barakate *et al.*, 1999¹⁰⁷ **Design:** Prospective interrupted time series (two phases)
Setting: Colorectal surgical ward **Location:** New South Wales, Australia **Dates:** 1 July 1995–31 Dec. 1997
Population characteristics: 28-bed^a surgical ward. ICT. MRSA initially endemic. LOS not reported
Stated aim of study: To determine the effect of ward renovation (and cleaning) plus electronic flagging and cohorting on MRSA acquisition rates
Major infection control changes during the study: Ward cleaning and refurbishment. Electronic flagging of readmission of previous MRSA patients

	Isolation	Screening	Eradication	Other measures
Phase 1 6 months (1 July 1995– 31 Dec. 1995)	Single rooms and cohorting in 2- or 4-bed rooms (closed bays)	None	None	Feedback from ICN when MRSA cases. Flagging medical records of MRSA cases. Gloves, gowns
Phase 2 22 months (1 Mar. 1996– 31 Dec. 1997)	As phase 1	As phase 1	As phase 1	As phase 1 + ward closure, cleaning and refurbishment (Jan.–Feb. 1996) From July 1996 electronic flagging of readmitted MRSA patients to allow immediate isolation/cohorting

Isolation details: 4 single rooms, 4 double rooms and 4 four-bed rooms^a

Screening details: N/a

Eradication details: Triclosan bathing for MRSA patients only

Reported outcomes:

1. Incidence:

Total MRSA: Monthly figures for total new MRSA cases detected reported.

MRSA detections/total patients admissions: 20/928 (phase 1); 64/3134 (phase 2)

Infections: Cases identified as 'swab positive'. Infection not differentiated from colonisation or defined

Colonisation: See above

MRSA carriage on admission: 20% considered to carry MRSA on admission in phase 1; 34% in phase 2

MRSA acquisitions: Per cent of MRSA cases considered to have been acquired in the ward: 80% (phase 1); 66% (phase 2)

Definitions: Carriage on admission: case-by-case assessment based on typing and patient movements. No formal rule set

2. Point prevalence: No data

3. Trends: 0–8 cases detected each month, with no apparent trend. Two months (one in each phase) had no new cases

MRSA strain details: No data. Phage typing and antibiotic sensitivities tested but not reported

Analysis in paper: No appropriate analysis (χ^2 test used to compare incidence data)

Major confounders and bias: Prevalence of MRSA and contemporaneous changes (e.g. in LOS) not reported

What the authors conclude: Renovation was not associated with a significant change in rate of MRSA detection during the study. Flagging and isolation/cohorting not associated with any change in MRSA detection

Assessment of authors' conclusions: Conclusions appears to be supported by the data. However, no prevalence data are presented so it is possible that there was a change in the transmission rate per MRSA patient, but that changes in prevalence nullified any impact

^a Additional information obtained from authors.

Study: Barakate *et al.*, 2000¹²⁰ **Design:** Prospective ITS (2 phases)
Setting: 1000-bed teaching hospital **Location:** New South Wales, Australia **Dates:** 1 July 1995–31 Dec. 1997
Population characteristics: Age (range; mean; median): 0–98; 62.7; 67.0. 68% of the study population were male. MRSA initially endemic (>20% of all *S. aureus*) ICT with one ICN per 1000 beds. Approximately 5000 admissions to hospital per month. Hospital has 40 wards. 140,000 patients admitted during whole study
Stated aim of study: To determine prospectively MRSA colonisation incidence in hospital clinical units and, using typing data, ascertain the ward or hospital in which patients became positive
Major infection control changes during the study: Isolation of readmitted MRSA patients

	Isolation	Screening	Eradication	Other measures
Phase 1 12 months (1 July 1995– 31 Jun 1996)	Single rooms and cohorting on closed bays for all known MRSA patients	Preadmission screening for selected patient groups. ICU patients screened three times per week	None	1. Gloves 2. Records of MRSA patients marked 3. MRSA patients excluded from orthopaedic and haematology wards 4. Linen change and fomite avoidance emphasised
Phase 2 18 months (1 July 1996– 31 Dec. 1997)	As above. Previous MRSA patients also isolated when readmitted	As above	As above	As above + electronic prompts when previous MRSA patients readmitted

Isolation details: ICUs 12 beds include 4 in single rooms. Other wards have 2–4 single rooms.^a Closed bays are 2–4-bed rooms

Screening details: Selected groups for preadmission screens (nose^a): cardiac surgery and elective orthopaedic surgery. Screening sites for ICU patients included CSU, endotracheal aspirates, surgical drain sites and venous access sites^a

Eradication details: none although daily triclosan bathing for colonised patients encouraged

Reported outcomes:

1. Incidence:

Infections: Quarterly MRSA bacteraemias reported: 25 in phase 1; 46 in phase 2 (see **Trends** below)

Colonisation: 995 patients became newly colonised. Incidence highest in ICU and services using that unit. Low incidence maintained in elective orthopaedic surgery and haematology (respectively <1 and 3 per 1000 admissions)

Carriage on admission: 17% of all new MRSA cases detected were considered to be acquired at referring hospitals

MRSA acquisitions: Most frequent sites of acquisition were considered to be the ICUs (17% of new detections). No acquisitions considered to have occurred in the haematology ward

Denominators: Data presented per 1000 admissions

Definitions: Infection: Not specified

Carriage on admission: Case-by-case assessment based on typing and patient movements. No formal set of rules

2. Point prevalence: No data

3. Trends: Time series of monthly MRSA detections per 1000 admissions shows no evidence of any change between phases or of a trend. Quarterly MRSA bacteraemias stayed almost constant (15–17 cases) throughout the study, except during the first quarter (8 cases)

MRSA strain details: One predominant strain (386/964 isolates). Lysed by phage 85 and 88. 33 other phage types. Two types accounted for 56% of isolates

Analysis in paper: No appropriate analysis (χ^2 test used to compare phases)

Major confounders and bias: Different screening effort between units (e.g. ICU and orthopaedics)

What the authors conclude: 1. Single-room isolation and cohorting failed to prevent MRSA spread

2. In tertiary referral hospitals with endemic and frequently imported MRSA, spread to patient groups (i.e. orthopaedic oncology and haematology) in whom MRSA is detrimental can be prevented by designating appropriate wards as 'MRSA-free zones'

Assessment of authors' conclusions: 1. Assertion is consistent with data, but will depend on how many cases resulted from cross-infection during current patient episodes and how many patients were colonised on admission. The authors' assessment of this was made on an *ad hoc* basis and insufficient data are presented to allow conclusions to be evaluated

2. Conclusion is plausible, but no screening in orthopaedic surgery and haematology so true rates of colonisation are not known. In contrast, ICU had extensive screening. Impact of introducing such a policy into a setting with endemic MRSA cannot be assessed from the data presented as the exclusion policy for orthopaedics and haematology was maintained throughout. No data on prevalence or numbers colonised on admission, which makes interpretation difficult

Notes: Subsequently hospital MRSA prevalence increased, although numbers remained low in haematology and orthopaedic wards^a

ICN, infection control nurse; CSU, catheter specimen urine.

^a Additional information obtained from authors.

Study: Blumberg and Klugman, 1994⁸¹ **Design:** 1-year cohort study with non-equivalent concurrent and equivalent historical (1-year) controls, and 1-year follow-up

Setting: ICU; paediatric oncology; non-targeted areas of tertiary hospital **Location:** Johannesburg, South Africa **Dates:** 1990–1992

Population characteristics: Population A: 20-bed ICU, paediatric and adult patients. Population B: 15-bed paediatric oncology ward. Population C: other (non-targeted) areas of hospital (~3000 beds). MRSA endemic in hospital. ICT

Stated aim of study: To investigate control of MRSA bacteraemia by a targeted programme

Major infection control changes during the study: patient isolation; eradication therapy; screening

	Isolation	Screening	Eradication	Other measures
Populations A and B (targeted areas)				
Phase 1 12 months 1990 ^a	None ^a	None ^a	None ^a	None ^a
Phase 2 12 months 1991 ^a	Single rooms in ICU (population A). NC in paediatric oncology (B)	All patients screened at start of phase and within 48 h of admission. Patients having undergone eradication therapy screened weekly for 3 weeks, then monthly. HCWs screened at start of phase or when they started work, and 6 months after start of phase	Topical eradication from patients and staff	Gloves, gowns
Phase 3 12 months 1992 ^a	Single rooms sometimes used in ICU, but no consistent policy ^a No NC	Some screening, but no consistent policy ^a	Some eradication, but no consistent policy ^a	
Population C (non-targeted)				
Phase 1 36 months 1990–1992 ^a	None ^a	None ^a	None ^a	None ^a

Isolation details: Frequent breakdown of nurse cohorting in population B during phase 2 due to staff shortages

Screening details: Patient screening sites: nose; perineum; axillae; hairline

Eradication details: Mupirocin and chlorhexidine used

Reported outcomes:

1. Incidence:

Total MRSA: Carriage in patients reported for populations A and B, phase 2 only: 17 carriers identified from 300 ICU patients; 5 carriers identified from 50 paediatric oncology patients

Infections:

No. of positive blood cultures/no. of cultures (ignoring repeat cultures from the same patient ^a)	1990 phase 1	1991 phase 2 (for A and B)	1992 phase 3 (for A and B)
Population A (ICU) bacteraemias	14/1391	4/1579	10/1934
Population B (paediatric oncology) bacteraemias	12/924	0/1026	3/815
Population C (non-targeted areas) bacteraemias	62/20,068	82/18,755	112/18,977

Definitions: Bacteraemia defined by a single blood culture yielding MRSA

2. Prevalence: No data

3. Trends: No additional data

4. Secondary outcomes: HCW carriage: carriers/no. screened (phase 2 data): 5/225 (population A); 5/65 (population B)

Economic evaluation: Cost data for cultures and eradication therapy provided

MRSA strain details: None

Analysis in paper: No appropriate analysis (χ^2 test used to compare incidence data)

Major cofounders and bias: Regression to the mean effects may be expected

continued

What the authors conclude: 1. The study demonstrates the efficiency of targeted MRSA control measures in a hospital with endemic MRSA. 2. An elimination of the carrier state significantly decreased the incidence of MRSA bacteraemia in both units

Assessment of authors' conclusions:

1. Conclusion seems to be supported by the evidence as the trend for increasing MRSA bacteraemias elsewhere in the hospital was reversed in the targeted units, and bacteraemias increased in 1992 when control programme had ended. The comparison of 1990 and 1991 data, however, is compromised by the fact that the 1990 data are only included (and the control measures taken) **because** of the high levels of MRSA in those units in that year. The increase in blood cultures in the ICU may be indicative of an increase in admissions and hence reduced LOS, which would represent an important confounder

2. It is not possible to assess the relative importance of the control measures taken

Notes: Populations A and B were targeted for control owing to the high rate of MRSA bacteraemias the previous year

^a Additional information obtained from authors.

Study: Brady *et al.*, 1990⁷⁷ **Design:** Retrospective ITS (3 phases). Report also includes a 2-month prospective observational study

Setting: Cardiothoracic surgical unit **Location:** New South Wales, Australia **Dates:** Jan. 1983–June 1988

Population characteristics: 37 beds and 2 wards in unit. 6269 patient operations performed during study. Endemic MRSA. ICT

Aim of study: To report experience in controlling MRSA

Major infection control changes during the study: Patient screening; ward closure; antibiotic therapy

	Isolation	Screening	Eradication	Other measures
Phase 1 37 months (Jan. 1983– Jan. 1986)	IW	None reported	Eradication therapy from patients carrying MRSA only in the nose	
Phase 2 5 months (Feb.–June 1986)	As phase 1	All patients screened at start of phase, pre- and postoperatively (between March and April)	As phase 1	1. Unit closed to new admissions at start of phase 2. Only MRSA-negative HCWs allowed to work on unit
Phase 3 24 months (July 1986– June 1988)	As phase 1	Patients screened days 1, 3 and 6 postoperatively and preadmission	As phase 1	1. Only MRSA-negative HCWs allowed to work on unit 2. Preoperative prophylaxis with cephalothin reduced

Isolation details: IW used for patients carrying MRSA extra-nasally

Screening details: Screening sites: nose; throat; perineum; wound; scars (preadmission). Additional screens during March–April 1986 as part of a 2-month prospective study: post-operative screens taken after 1, 2, 3 and 6 days

Eradication details: Topical agent: bacitracin. Triclosan bodywashes for all patients introduced in phase 2

Reported outcomes:

1. Incidence:

MRSA: Time series of monthly MRSA cases

Infections: Time series of monthly MRSA-infected patients

Colonisation: Time series of monthly MRSA-colonised patients (i.e. those without bacteraemias or wound infections)

MRSA carriage on admission: No data

Attributable mortality: No data

Denominators: Number of operations per year reported (range: 1278–1367; 709 in first half of 1988)

Definitions: Infection: wound infections and bacteraemias. Wound infection definitions from Ref. 310

2. Point prevalence: No data.

3. Trends: (i) Annual MRSA infected patients increased from 9 in 1983 to peak at 18 in 1985 (phase 1), then fell to 14 and 2 in 1986 (phases 2 and 3) and 1987 (phase 3), increasing to 5 in first half of 1988 (phase 3)

(ii) Annual total MRSA incidence shows similar pattern of increase, peaking in 1986 (particularly high rates coinciding with additional screening during the prospective study), followed by a decrease, reaching a level slightly below that of 1983 in 1987–88

(iii) Monthly data show initial gradual increase of clustered cases, with substantial reduction in incidence in phase 3

Economic evaluation: No data

MRSA strain details: Considerable diversity in phage types. All resistant to penicillin, erythromycin, tetracycline, sulphamethoxazole, trimethoprim and clindamycin. 23.7 and 43.5% of strains were resistant to chloramphenicol and neomycin, respectively; 97.5% of strains were gentamicin and kanamycin resistant

Analysis in paper: No appropriate analysis of time series data (χ^2 test used). 1986 outcomes omitted in χ^2 test

Major confounders and bias: Change in screening practice. Regression to the mean effects. Data are vulnerable to changes in imported cases. Some evidence that seasonal effects may be important

What the authors conclude: 1. There was a highly significant reduction in MRSA

2. Routine postoperative monitoring of perineal colonisation helped in detecting potential increases in MRSA in the unit and allowed action before levels led to outbreaks

Assessment of authors' conclusions: 1. There was a reduction in infections in later phases, but the interventions were prompted by increased incidence so regression to the mean may be expected. Also, the total MRSA incidence in phase 2 may be inflated by additional screening

2. Data do not allow the impact of any single measure to be assessed

Notes: Report includes details of a 2-month prospective surveillance (non-interventional) study between March and April 1986. Additional control measures were introduced gradually after evaluation of the results, and were fully in place by the beginning of phase 3

Study: Campbell *et al.*, 1998⁸⁵**Design:** Prospective ITS (3 phases)**Setting:** NICU**Location:** Texas, USA**Dates:** May–Dec. 1995**Population characteristics:** 48 beds. Mean daily census: 37 infants. Mean gestational age for MRSA-infected infants: 31 weeks. MRSA endemic. NICU based in a 206-bed women's and infants' hospital**Stated aim of study:** To describe the epidemiology, interactions and typing during investigations and control of concurrent outbreaks of *S. marcescens* and MRSA in an NICU**Major infection control changes during the study:** Patient screening; HCW education

	Isolation	Screening	Eradication	Other measures
Phase 1 ~2 months (7 May–9 July 1995)	IW	All infants screened weekly	None described	1. Gloves, gowns 2. Triple dye used for umbilical care
Phase 2 ~1 month (10 July– 14 Aug. 1995)	As phase 1	All infants screened twice weekly	None described	1. As phase 1 + 2. Handwashing education and feedback (from 14 July) 3. Extra sinks (from 31 July)
Phase 3 ~4 months (15 Aug.– 11 Dec. 1995)	As phase 1	As phase 2	None described	1. As phase 2 + 2. Additional HCW education on IV insertion and maintenance

Isolation details: 4-bed isolation ward for MRSA patients**Screening details Sites:** throat and rectum**Eradication details:** no eradication therapy reported**Reported outcomes:****1. Incidence:***Total MRSA:* 15 colonised or infected infants during study*Infections:* 5 bacteraemias during study. 4-weekly incidence reported*Colonisation:* 10 colonised infants during study. 4-weekly incidence reported*MRSA carriage on admission:* No data, but mean interval from admission to infection of 3 weeks, and almost all strains were of a single PFGE type*Denominators:* None*Definitions:* Infections: positive blood culture + another site of sepsis (e.g. i.v. site)**2. Point prevalence:** No data**3. Trends:** Too few data points to identify clear trends, but no MRSA found after Oct. 30. One bacteraemia in first three 4-week periods, two in the next 4 weeks, then no further infections from phase 3. Before fadeout 1–2 new MRSA cases in each 4-week period apart from one in phase 2 which had 6 cases**Economic evaluation:** None**MRSA strain details:** 4 out of 5 infecting and 7 out of 9 colonising MRSA strains were identical by PFGE typing. The 5th infecting strain was closely related. One isolate was not available for typing**Analysis in paper:** No appropriate analysis of time series data: Fisher's exact test used**Major confounders and bias:** Regression to mean likely to be important as interventions made in response to higher than normal colonisation rate**What the authors conclude:** 1. Patient isolation contributed to control, together with strict adherence to NICU policies and procedures

2. Increased numbers of nursing staff probably contributed to control

Assessment of authors' conclusions: 1. Patient isolation did not change during study, so cannot assess its contribution to control. Rate of colonisation and infections did not decrease after initial education and feedback (phase 2), suggesting they may not have been important. However, without prevalence data cannot assess whether transmission rate per source changed. Cessation of infections after additional HCW education in phase 3 provides some support for their efficacy, but stochastic fadeout would not have been unlikely and many other factors could have contributed to termination of outbreak

2. Timing of changes in nursing staff numbers not presented, so cannot assess this intervention

Study: Coello *et al.*, 1994¹¹⁸ **Design:** Prospective ITS (3 phases)
Setting: Teaching hospital **Location:** Madrid, Spain **Dates:** July 1989–Dec. 1992
Population characteristics: 1500 beds. MRSA not initially endemic. Mean (SD) age of patients with hospital-acquired MRSA: 68.6 (17.2); range: 3–99
Stated aim of study: To investigate prospectively the distribution of patients with carriage, colonisation and infection in a large hospital outbreak
Major infection control changes during the study: Patient isolation; screening; eradication

	Isolation	Screening	Eradication	Other measures
Phase 1 8 months (July 1989– Feb. 1990)	None	None	Topical eradication with neomycin cream for nasal carriers ^a	None
Phase 2 8 months (Mar. 1990– Oct. 1990)	None	None	Topical eradication with mupirocin + chlorhexidine for MRSA carriers	None
Phase 3 26 months (Nov. 1990– Dec. 1992)	Single-room isolation + cohorting on closed bays, both with designated nursing staff ^a	Contacts of MRSA patients. ^a Admission screens of patients with previous MRSA. ^a HCWs caring for MRSA patients screened monthly, otherwise HCW contacts screened if >1 case in high-risk areas, or several cases in low-risk areas ^a	As phase 2	1. Aprons, masks, gloves ^a 2. Early discharge of MRSA patients ^a Measures were local modification of 1990 UK guidelines ⁴¹

Isolation details: In phase 1 and 2 isolation was recommended for MRSA patients, but recommendations not usually followed.^a 64 1- or 2-bed rooms for isolating MRSA patients in phase 3.^a Overflow cohorted in 4–6 bedded rooms^a

Screening details:^a In phase 2 screening of MRSA contacts was recommended, but recommendations usually not followed. Screening sites: nose and perineum for contacts of MRSA cases; nose, axillae and lesions for HCWs; nose, perineum, lesions, throat, axillae and groin for previously positive patients

Eradication details: Clearance defined by three negative screens

Reported outcomes:

1. Incidence:

Total MRSA: MRSA isolated from 1074 patients by Oct. 1992

Infections: Monthly incidence per 1000 admissions of infected patients reported. 476 infected patients throughout study

Bacteraemias: 91 MRSA bacteraemias throughout study

Colonisation: Monthly incidence per 1000 admissions reported

MRSA carriage on admission: 55 cases were previously identified positive patients. Of the 990 newly identified cases, 928 acquired the organism after admission. Time of acquisition indeterminate for 51 patients with previous hospitalisations

Attributable mortality: MRSA was thought to be the cause of death in 62 of the 476 infected patients

Definitions: Hospital-acquired MRSA: isolation of MRSA at least 48 h after admission from patients without previous hospitalisation. Infections: CDC³¹¹

2. Hospital point prevalence: No data

3. Trends: MRSA infections very low and slowly increasing in phase 1. Rapid increase in first half of phase 2 with levels apparently plateauing in last 3 months. Numbers peaked in Nov. 1990, then declined slowly throughout phase 3, eventually approaching the low levels found in phase 1. Colonisations very low in phases 1 and 2 (when there was minimal screening), increased sharply in phase 3 (with onset of screening programme) and declined slowly throughout this phase

4. Secondary outcomes: MRSA isolated from nose in 72 staff on 55 occasions, from 2303 screening swabs, the highest prevalence coinciding with the peak of the outbreak

Economic evaluation: None

MRSA strain details: 25 of 29 strains tested were lysed by experimental phages 29/77/55/932. Most isolates sensitive only to vancomycin, trimethoprim, chloramphenicol, fosfomycin, fusidic acid and mupirocin

Analysis in paper: None

Major confounders and bias: Many potential confounders about which there is little or no information

continued

What the authors conclude: 1. Screening found an extra 403 asymptomatic carriers (43% of total outbreak) (data to October 1992)

2. Identification and treatment of carriers coincided with reduction in newly infected patients and outbreak control, confirming the importance of asymptomatic carriage for sustaining the outbreak

Assessment of authors' conclusions: 1. Clearly many additional cases were detected by screening

2. Reduction in incidence of infections does coincide with additional measures in phase 3, and data support assertion that asymptomatic carriers were important for continued spread

^a Additional information obtained from authors.

Study: Cosseron-Zerbib *et al.*, 1998⁸⁴ **Design:** Hybrid retrospective (phase 1) and prospective (phase 2) ITS
Setting: PICU **Location:** Paris, France **Dates:** Apr. 1992–Dec. 1995

Population characteristics: MRSA initially endemic. 20-bed PICU. Age range: 0–15 years. Mean LOS: 7.3 days. ~600 admissions to the unit per year. ICT

Stated aim of study: To assess the efficacy of an MRSA control programme

Major infection control changes during the study: Patient isolation, screening, staff education and feedback

	Isolation	Screening	Eradication	Other measures
Phase 1 21 months (Apr. 1992– Dec. 1993)	None	None before Feb. 1993. After Feb. 1993 all patients screened weekly	None	None
Phase 2 24 months (Jan. 1994– Dec. 1995)	Single-room isolation or cohorting on closed bays (during outbreaks)	All patients screened on admission and at weekly intervals. Reservoir looked for when MRSA cases found	None. Only infected patients received antibiotics	1. Feedback to staff of surveillance data 2. Handwashing education 3. Chlorhexidine soap used for contacts with MRSA patients 4. Supervised application of IC measures by the identified members of PICU staff with IC responsibilities 5. Nursing staff began care with non-MRSA patients ⁹

Isolation details: Four single-bed rooms available⁹. MRSA-positive patients remained in isolation until presumed eradication

Screening details: Screening sites: nose and perineum. No enrichment

Eradication details: Criteria for presumed eradication: two negative cultures 1 week apart

Reported outcomes:

1. Incidence:

Infections: Time series of 6-monthly MRSA infection incidence density (infections per 1000 patient days) presented. Infections and patient days within 48 h of admission ignored in incidence density calculation

Aggregated results:

	Phase 1	Phase 2
MRSA infections	50	6
MRSA infection incidence per 1000 patient days	5.9	0.8
MRSA bacteraemias per 1000 patient days	0.64	0.097
MRSA LRT infections per 1000 patient days	0.0	0.12

Definitions: Infections: CDC.³¹¹ Carriage on admission: positive swabs within 48 h of admission considered to indicate patients positive on admission

2. Prevalence: Time series of 6-monthly MRSA carriage prevalence (per cent of cultured patients carrying MRSA ignoring identical strains from repeat swabs within a 30-day period)

3. Trends: Incidence density consistently higher in phase 1 (4–7) than phase 2 (<1.5). Reduction coincides with introduction of control measures. No evidence of a trend for declining incidence in phase 1, some suggestion of decreasing incidence density in phase 2. MRSA carriage prevalence time series from phase 1 starts in Feb. 1993 and has two data points which show a fall from almost 35% to about 19%, but time series is too short to assess whether there is a decreasing trend or not. In phase two prevalence fell to, and remained below, 5%

4. Secondary outcomes: Ratio of MRSA to total *S. aureus* also presented as a time series and follows a very similar pattern to the incidence density of MRSA infections

MSSA infections (phases 1 and 2): 4, 10. MSSA infection incidence/1000 patient days (phases 1 and 2): 0.5, 1.3

Economic evaluation: Authors argue that expenditure on admission screening is justified as there is a constant reintroduction of MRSA due to patient transfers. No quantitative justification is presented

MRSA strain details: None given

Analysis in paper: No appropriate analysis (χ^2 used to compare incidence data)

Major confounders and bias: Retrospective nature of data in phase 1 suggests that regression to the mean effects could be important, for example if the intervention was made in response to a higher than usual level of MRSA

What the authors conclude: 1. The programme was effective in controlling high MRSA infection rates in the PICU
 2. Lack of molecular epidemiology did not impede the programme

continued

Assessment of authors' conclusions: 1. The evidence supports this, though there are a number of potentially important sources of bias. In particular, the hybrid retrospective–prospective design means that regression to the mean and Hawthorne effects may be important. Although the time series is too short to allow a formal analysis, it does lend considerable additional weight to the authors' conclusion, above that from the aggregated data alone

^a Additional information obtained from authors.

Study: Cox *et al.*, 1995⁸⁸

Design: Retrospective ITS from three hospitals

Setting: District general hospital (hospital A) and two long-stay/rehabilitation hospitals (B and C)

Location: Kettering, UK

Dates: Apr. 1991–Dec. 1992

Population characteristics: MRSA described as epidemic (not initially endemic). 750 beds (in total)^a. Median age for all three hospitals: 78. Age range: 17–99. ICT covered all sites^a

Stated aim of study: To describe the epidemiology, laboratory characterisation and control methods used to contain an EMRSA16 outbreak

Major infection control changes during the study: Patient isolation (including IWs) and screening. Authors followed 1990 UK working party guidelines⁴⁰

	Isolation	Screening	Eradication	Other measures
Hospital A				
Phase 1 5 months (Apr.–16 Sept. 1991)	Single rooms and cohorting on closed bays with designated nursing staff ^a for cases and those awaiting screening results	Extensive screening: patients on affected wards screened weekly until no cases for 3 weeks; admission screens for intra- and inter-hospital transfers; weekly screens for patients having had MRSA eradication therapy; follow-up screens for discharged MRSA-positive patients until negative. Staff screening in most affected areas	Topical eradication from patients and staff (mupirocin and chlorhexidine). Systemic eradication of throat carriage (rifampicin and fusidic acid)	Staff with throat MRSA carriage excluded from work
Phase 2 4 months (17 Sept. 1991–3 Feb. 1992)	Overflow accommodated in single rooms, then main ward bays ^a	As above (with additional screening sites) + preadmission swabs for recently exposed elective surgery patients and emergency admissions	As above + postdischarge eradication	1. As above + 2. Ward closure + 3. Ward cleaning
Phase 3 11 months (4 Feb.–Dec. 1992)	Isolation ward (12 beds) No overflow	As above, except no admission screening for emergency admission	As above	As above
	Isolation	Screening	Eradication	Other measures
Hospital B				
Phase 1 5 months Apr.–Sept. 1991	As hospital A, phase 1 ^a	As hospital A, phase 1	As hospital A, phase 1	As hospital A, phase 1
Phase 2 15 months (Sept. 1991– Dec. 1992)	IW in hospitals C and A Some cohorting, sometimes no isolation	As hospital A, phase 2	As above	1. As above + 2. Ward cleaning
Hospital C				
Phase 1 5 months (Apr.–Sept. 1991)	As hospital A, phase 1 ^a	As hospital A, phase 1 ^a	As hospital A, phase 1	1. Staff with throat MRSA carriage excluded from work 2. Ward cleaning
Phase 2 10 months (Sept. 1991– Aug. 1992)	NC on a closed bay (6 beds), then separate IW (7 beds). No overflow	As hospital A, phase 2	As above	As above
Phase 3 5 months (Aug.–Dec. 1992)	IW in hospital A or single-room isolation ^a	As above	As above	As above

continued

Isolation details: Hospital A: 36 single rooms (excluding paediatrics and maternity).^a Phase 2 isolation ward had 4 beds, but capacity was exceeded in Jan. 1992. Larger ward in phase 3 closed on 9 Dec. 1992.

Hospital B: 1 single room.^a MRSA patients moved to IW in hospital C (Sept. 1991–July 1992), or hospital A (July–Dec. 1992)^a

Hospital C: 11 single rooms.^a 7-bed IW used between 30 Oct. 1991 and 7 July 1992^a

Screening details: Sites screened included nose, wounds, lesions and CSU (all); throat and perineum (staff, previously positive patients); axillae, groin and hairline (newly diagnosed cases). Throat swabs for transferred and previously positive patients started in Feb. 1992 and perineal swabs introduced for transfers, contacts and previously positive patients in Sept. 1991. No enrichment, except after Nov. 1991 for swabs from previously positive patients

Eradication details: Also included povidone iodine for eradication from some bedsores, ulcers and broken skin. Clearance defined by 3 successive weekly sets of negative swabs

Reported outcomes:

1. Incidence:

Infections: monthly incidence of infected patients recorded for each hospital. Total MRSA septicaemia: 5. Total MRSA pneumonias: 22. Total MRSA direct deaths: 7

Colonisation: Monthly incidence of colonised patients recorded for each hospital

MRSA carriage on admission: No data

MRSA acquisitions: No data

Attributable deaths: 7 throughout study

Denominators: None except total swabs taken per month for all three sites were reported. These steadily increased after phase I, then peaked in July 1992, at about 5 times the phase I level

Definitions: Infection: not specified

2. Point prevalence: No data

3. Trends:

Hospital A (district general): Total MRSA cases detected per month increased from 2 (Apr.–June 1991) and peaked at 36 in Jan. 1992. Monthly numbers remained fairly stable between Feb. and Nov. 1992 (range: 8–26) before falling suddenly to 2 cases in Dec. 1992. Most of the variation is accounted for by changes in numbers of colonised patients detected. Monthly incidence of MRSA infections changed little throughout study period (range: 1–4).

Hospital B (rehabilitation/long stay): No readily apparent trends in total MRSA cases detected (0–6 cases/month throughout study). Four infections occurred, all in the first 4 months

Hospital C (rehabilitation/long stay): Total monthly MRSA cases started at 1 in Apr.–May 1991, peaked at 12 in March 1992, then declined to a low level (1–3 cases/month) between May and Oct. 1992. No further cases after Oct. 1992. Never more than 2 infections per month. No infections after Apr. 1992

Secondary outcomes: HCW carriage: 27 of 5125 (0.5%) staff screened were positive

Economic evaluation: Total cost estimated to be at least £403,600, representing additional cost of containing the outbreak (excluding staff time implementing control plan). IW estimated to have cost £303,600 and microbiology £43,000

MRSA strain details: All but five isolates were EMRSA-16. All resistant to penicillin, erythromycin and ciprofloxacin. Most isolates also resistant to gentamicin and trimethoprim

Analysis in paper: None

Major confounders and bias: Colonisation data will be affected by very large changes in screening effort. Many other potentially important confounders with no recorded data

What the authors conclude:

1. Single-room isolation and cohorting failed to control the outbreak
2. IWs, eradication of carriage and screening of patients discharged from wards having had MRSA were key parts of the strategy that eventually contained the outbreak

Assessment of authors' conclusions:

1. Chain of transmission apparently persisted at hospital A, suggesting the outbreak was not controlled. Unclear how many of the cases at hospitals B and C were colonised on admission, as many patients would have been transferred from hospital A. It is therefore possible that control was achieved at B and C but not at A

2. Not clear that containment was achieved as only 1 month with greatly reduced colonisation incidence, after which IW at hospital A closed and study terminated. No clear temporal relationship between reductions in incidence and control measures. In hospital A establishment of IW and other interventions was not followed by noticeable changes in incidence of MRSA infections. Incidence of colonisation in all three hospitals difficult to interpret owing to large changes in patient screening, and all results difficult to interpret owing to lack of prevalence data and denominators

^a Additional information obtained from authors.

Study: Duckworth *et al.*, 1988⁸⁹ **Design:** Retrospective ITS (6 phases)
Setting: 645-bed teaching hospital **Location:** London, UK **Dates:** June 1982–Nov. 1986
Population characteristics: Approximately 60 new admissions/day. MRSA initially epidemic
Stated aim of study: Outbreak report
Major infection control changes during the study: Patient isolation, topical eradication, screening, ward closures

	Isolation	Screening	Eradication	Other measures
Phase 1 4 months (June–Sept. 1982)	Single rooms	None ^a	None ^a	
Phase 2 3 months (Oct.–Dec. 1982)	Cohorting in open bay in neurosurgery. ^a Single rooms elsewhere	Neurosurgery HCWs and patients (once). ICU HCWs and patients (twice). MRSA + HCWs	Topical eradication with chlorhexidine attempted in patients and HCWs	1. Gloves and gowns 2. Staff carriers taken off duty 3. Ward closure
Phase 3 13.5 months (Jan. 1983–mid-Feb. 1985)	Single rooms	None ^a	(probably chlorhexidine) ^a	Gloves and gowns
Phase 4 4 months (mid-Feb.–late June 1985)	IW	Patients admitted to previously screened wards. Contacts of MRSA patients (patients and HCWs) on all wards in turn. HCWs	Topical eradication with chlorhexidine and mupirocin attempted in patients and HCWs	1. Gloves, gowns and aprons 2. Staff extra-nasal carriers taken off duty 3. Interhospital transfer of some MRSA patients 4. Records of MRSA patients marked Gloves and gowns
Phase 5 7 weeks (June–Aug. 1985)	Cohorting on a single bay and single rooms ^a	HCWs and patients on cohort ward screened weekly. Patients admitted to previously screened wards. Contacts of MRSA patients (patients and HCWs)	As above ^a	Gloves and gowns
Phase 6 26 months (Aug. 1985–Nov. 1986)	IW	As above, except only high-risk patients screened on admission ^a	As above ^a	Gloves and gowns

Isolation details: ~3 single rooms on each 26-bed ward. Different IWs were used in phases 4 and 6, but neither was purpose-built or had controlled ventilation. Both had 14 beds

Screening details: Screening sites included nose and lesions. From phase 4 additional sites included CSU, sputum, abnormal skin, peritoneal and haemodialysis sites, and initially perineum, wrists and axillae (but discontinued owing to low detection rates). High-risk patients were defined as: hospital transfers; inpatients in previous year; previous MRSA-positive patients. No enrichment

Eradication details: MRSA clearance defined as three negative weekly screens^a

Reported outcomes:

1. Incidence:

Infections: Cumulative sums of weekly incidence of MRSA infections reported (assuming two new cases per week). ~408 MRSA infections during whole study

Denominators: None

Definitions: Infection: not specified

2. Point prevalence: No data

3. Trends: There were fewer than 2 new infections per week in phase 1, phase 2 and the first half of phase 3. In the second half of phase 3 incidence increased and was sustained at a higher level throughout the phase. In phase 4 the incidence declined from 3–4 infections per week and remained stable at a reduced level (1–2 infections per week) throughout the rest of the study. Total eradication was not achieved

continued

Economic evaluation: No data

MRSA strain details: EMRSA-1. Initially phage type 55, then 55/85, and by mid-55 non-typeable with standard phage

Analysis in paper: None

Major confounders and bias: Potential for large performance bias, as no recording of potential confounders

What the authors conclude: The outbreak was not controlled by single rooms, and containment was only achieved with a combination of screening, mupirocin and an IW. The IW contributed much to containment of outbreak

Assessment of authors' conclusions: Highest rate of new infections occurred in phase 3. The decrease after subsequent interventions (IW, eradication and screening) provides suggestive evidence for their effectiveness. Impossible to assess effect of any one measure. Lack of MRSA prevalence and colonised-on-admission data makes interpretation of outcomes difficult

^a Additional information obtained from authors.

Study: El Hagrasy, 1997⁸⁷ **Design:** Retrospective ITS (2 phases)
Setting: General hospital (550 beds) **Location:** Abu Dhabi, UAE **Dates:** Late June 1994–Dec. 1994
Population characteristics: No previous MRSA. Mean age of MRSA patients: 36 (range 1–77). ICT, with one ICN. Mean length of stay: 6.7 days. Mean length of stay for MRSA patients: 55 days. Mean daily admissions: 50.5 in 1994
Stated aim of study: To report the first major outbreak of MRSA in the hospital
Major infection control changes during the study: Changes to patient isolation, screening, eradication and early discharge

	Isolation	Screening	Eradication	Other measures
Phase 1 1.5 months (late June– 12 Aug. 1994) ^a	Cohorting on closed bays	All patients screened on admission, 3 days postadmission, and weekly. Patient contacts of MRSA patients. HCW contacts of MRSA patients (screened twice)	Topical eradication in patients with mupirocin and povidone iodine ^a	Handwashing education. Barrier nursing. Cleaned after rest of ward with separate equipment
Phase 2 4.5 months (13 Aug ^a – Dec. 1994)	IW	Patients in high-risk areas 3 days postadmission. Patient contacts of MRSA patients. Cleared MRSA patients screened every 3 days ^a	Topical eradication in patients and staff with mupirocin and chlorhexidine washing	Handwashing education. Handwashing with chlorhexidine. Gloves, masks, aprons for IW staff. Early discharge, even if still carrying MRSA. Staff told to minimise patient contact. No visitors allowed

Isolation details: In phase 1 MRSA patients isolated in 2-bed rooms at the end of each ward which held 1 or 2 patients. No overflow. Barrier nursing abandoned during phase 1 owing to staff shortage. IW had 16 beds (8 × 2-bed rooms), and was able to accommodate all MRSA patients

Screening details:^a Screening sites: nose (admission and weekly screens); nose and hands (HCWs); nose, perineum, axillae and rectum (patient contacts); nose, perineum, lesions, axillae, groin and wound (cleared MRSA patients)

Eradication details:^a Systemic eradication (with vancomycin, minocycline, or ciprofloxacin + rifampicin) when topical eradication failed. Eradication defined by 3 negative swabs at 3-day intervals. Chlorhexidine body washes and cream for MRSA + neonates. Nurses taken off duty during eradication

Reported outcomes:

1. Incidence:

Total MRSA: Monthly incidence reported. 45 infected or colonised patients over whole study.

Incidence per 100 admissions reported for 2 months only: 0.13 (Aug.); 0.02 (Dec.)

Infections: 19 patients had MRSA infections, including 2 bacteraemias

Colonisation: 26 patients were colonised only

MRSA carriage on admission: No data, but first reported MRSA outbreak in hospital so most cases assumed to be acquired

MRSA direct deaths: 0 (9 affected patients died)

Definitions: Infections: signs + symptoms of clinical infection.

Carriage on admission: positive swabs within 72 h of admission

2. Point prevalence: No data

3. Trends: Monthly incidence increased each month from 5 (June), peaked at 13 (Aug.), then fell each month to reach 2 in Dec.

4. Secondary outcomes: MRSA in HCWs Cases/number screened: 3/120

Economic evaluation: No data

MRSA strain details: All isolates resistant to cephalosporins, ciprofloxacin, erythromycin and aminoglycosides (except for 3 of the 45 strains which were sensitive to amikacin)

Analysis in paper: None

Major confounders and bias: No recording of any potential confounders; potential for reporting bias is high

What the authors conclude: 1. Barrier nursing did not stop the outbreak, which came to end in Jan. 1995 only after the establishment of an IW

2. Study shows that isolation of patients is the single most effective tool in combating MRSA

Assessment of authors' conclusions:

1. Evidence supports statement: transmission persisted during phase 1

2. Not shown. Cannot estimate contributions of different measures (early discharge, for example, could have been important)

^a Additional information obtained from authors.

Study: Esveld *et al.*, 1999¹⁰⁹ **Design:** Retrospective cohort study based on systematically collected survey data
Setting: Dutch hospitals **Location:** The Netherlands **Dates:** July 1994–June 1996
Population characteristics: Results based on questionnaire-based survey of all reported index cases of MRSA in Dutch hospitals over the study period. 296 index cases occurred over period, and there were 231 (78%) returned questionnaires. 10 index cases caused secondary cases only in staff and were excluded from analysis
Stated aim of study: To study the spread of MRSA in hospitalised patients, considering secondary MRSA infections in relation to strain origin and isolation measures
Major infection control changes during the study: No temporal changes, but the occurrence of secondary cases was compared between two groups defined by whether or not isolation occurred immediately on intake of index MRSA cases according to national guidelines

	Isolation	Screening	Eradication	Other measures
Group A: isolated				
Phase I 2 years (July 1994– June 1996)	Single rooms for MRSA cases and contacts. Cohorting with designated nursing staff when several MRSA cases	Screening of patient contacts of MRSA cases when cases detected and prior to transfer of contacts. HCW contacts screened twice weekly	Topical eradication in all MRSA carriers with mupirocin + chlorhexidine/povidone iodine washing	'Strict' patient isolation on admission according to national WIP guidelines. ³¹² Includes: gowns, gloves, masks, cap
Group B: not isolated				
Phase I 2 years (July 1994– June 1996)	No immediate isolation on admission, or other isolation policy	No standard policy reported	No standard policy reported	Patients isolated too late (i.e. not on admission) or not according to national guidelines

Isolation details: Dutch national WIP guidelines specify single rooms with negative pressure. Patients transferred from hospitals overseas or known to have MRSA also isolated until shown to be free of MRSA³¹²

Screening details: National guidelines specify screening sites: nose, perineum, throat, faeces, sputum, urine (if catheterised), skin lesions and wounds

Eradication details: National guidelines also specify systemic eradication as recommended locally

Reported outcomes:

1. Incidence:

Total MRSA: 483 MRSA isolates returned by Dutch hospitals to reference laboratory over study period

Infections: No data

MRSA carriage on admission: 296 of the 483 isolates were index cases

MRSA acquisitions: 187 secondary MRSA cases in patients and staff, which occurred in 34 clusters (i.e. short epidemics).

10 of these clusters of secondary cases occurred amongst HCWs only, and were excluded from subsequent analysis.

The remaining 30 clusters affected 159 people. Most clusters (24) affected 2–5 people, four affected 6–10, one affected 11 and one affected 42

	Group A: isolated	Group B: not isolated
Index cases leading to secondary cases	4	19
Sporadic cases (no secondary spread)	69	76

Definitions: Criteria used to define MRSA carriage on admission: not considered explicitly, but index cases can be assumed to have carried MRSA on admission. Index cases were defined as the first cases with an MRSA isolate of a new type unrelated to previous MRSA isolates. Secondary cases were defined as infected or colonised patients or staff with the same strain type as the index case, at the same hospital, within 5 months of the index case. Sporadic cases were defined as index cases not leading to secondary cases

2. Prevalence: No data

3. Trends: No data

MRSA strain details: Phage typing conducted by reference laboratory, but no information reported

Analysis in paper: Odds ratio (and 95% CI) for transmission occurring without and with immediate isolation according to guidelines reported: 4.3 (1.3 to 18.2) (CI not as reported in paper but recalculated using exact confidence intervals).

$p = 0.007$ from 2-sided Fisher's exact test

Possible risk factors analysed using Mantel–Hansel procedure

continued

Major confounders and bias: Some recording of potential confounders, suggesting that MRSA strain sources and patient risk factors are potential confounders. Selection of study population has potential for bias, due to differential response rates to questionnaire

What the authors conclude: Strict isolation according to the Dutch national guidelines appeared to prevent secondary infections in most cases. However, even strict isolation could not prevent all spread

Assessment of authors' conclusions: Study provides evidence that isolation helps to control spread of MRSA. However, other plausible explanations cannot be ruled out

WIP, Werkgroep Infectiepreventie.

Study: Faoagali *et al.*, 1992⁷⁶ **Design:** Retrospective ITS (2 phases)
Setting: Tertiary hospital **Location:** Brisbane, Australia **Dates:** 1975–89
Population characteristics: 1200 beds. Local patient drainage area: 300,000. MRSA not initially endemic. 449,779 patients admitted between 1979 and 1989. ICT; one ICN/1200 beds
Stated aim of study: To describe experience of managing MRSA
Major infection control changes during the study: Patient isolation; MRSA eradication; handwashing education; patient screening; antibiotic policy

	Isolation	Screening	Eradication	Other measures
Phase 1 7 years (1975–81)	Isolation ward ^a Minimal overflow ^a	ICU, burns and neurosurgery patients screened on admission	No consistent policy ^a	Gloves, gowns, masks ^a
Phase 2 8 years (1982–9)	IW Overflow isolated in single rooms Segregation of high-risk MRSA-free patients	Segregated patients screened once or twice/week. All transfers or admissions to segregated areas prescreened	No consistent policy ^a	Handwashing education, extra handbasins and antiseptic handwash. Restriction of antibiotics

Isolation details: 30-bed isolation ward for all MRSA patients at a site separated from the main hospital.^a Negligible overflow in phase 1.^a 20 single rooms for the considerable overflow in phase 2.^a Phase 2 segregation achieved by only admitting prescreened patients to segregated areas. High-risk patients considered to be burns, oncology, orthopaedic and neurosurgery, etc.

Screening details: Screening sites:^a nose, perineum, lesions and groin

Eradication details: Occasional topical eradication with mupirocin and chlorhexidine in phase 1.^a Eradication initially attempted in phase 2 (unsuccessfully)

Reported outcomes:

1. Incidence:

Total MRSA: Yearly figures reported throughout study. 5343 cases throughout whole study

Infections: MRSA bacteraemias reported annually from 1979. 205 bacteraemias in total between 1979 and 1989

Colonisation: No data

MRSA carriage on admission: No data

Denominators: Yearly total admissions reported from 1979

Definitions: Infection: Not specified

2. Point prevalence: No data

3. Trends: (i) Total new MRSA cases remained between 0 and 2 cases/year between 1975 and 1978. Subsequently numbers more than doubled each year in phase 1 between 1979 and 1981 (from 11 to 61 cases). Numbers rose rapidly at start of phase 2 in 1982 and 1983 to 447 and 754 then stabilised near 600/year in 1985–6 before reaching 811, 711 and 720 in the final 3 years.

(ii) MRSA bacteraemias rose from 0–6 in 1979–81 (phase 1) to 14 and 32 at start of phase 2 in 1982 and 1983, subsequently falling in the next 3 years to reach 12 in 1986, then rising again each year to peak at 39 in 1989

2. Secondary outcomes:

MRSA/MSSA ratio: Numbers of MSSA bacteraemias and per cent of *S. aureus* bacteraemias due to MRSA reported annually for 1979–89.

Per cent of *S. aureus* bacteraemias due to MRSA increased every year from 1979 to 1981 (0 to 10%) (phase 1), then rose to 18, 34 and 37% in the next 3 years (phase 2), fluctuating between 24 and 30% in 1985–9, except for a sharp fall to 14% in 1986. MSSA bacteraemias increased from 40 in 1979 to 99 in 1989, most of the increase occurring in the last 4 years

Economic evaluation: None

MRSA strain details: All isolates were resistant to penicillin, erythromycin and trimethoprim. ~90% were resistant to gentamicin, throughout study. Between 1982 and 1989 resistance to rifampicin and fusidic acid appeared in 20% of isolates tested

Analysis in paper: None

Potential cofounders and bias: Increasingly resistant MRSA isolates between 1982 and 1989 reported. Large increase in number of admissions in 1989, may explain slight downturn in MRSA expressed as a percentage of number of admissions and suggests concomitant changes in LOS, bed occupancy, and staff workload are possible but no data available. Change in screening effort in phase 2 may affect total MRSA numbers, but not MRSA bacteraemias

continued

What the authors conclude: 1. Interventions initiated early appear to have had no effect on course of epidemic
2. The later downturn in detection of new cases was not due to changes in infection control practice

Assessment of authors' conclusions:

1. Clearly the control measures failed to prevent spread or endemicity from being established. However, there is no basis for statement that interventions had no effect, as they could have delayed onset of epidemic, reduced the rate of increase or lowered the ultimate endemic level

2. It is possible that the stabilisation seen in phase 2 was related to infection control changes despite the fact that it did not immediately follow the intervention as some of the interventions (such as staff education and antibiotic policy) may only have an effect over longer periods of time. Furthermore, without additional control measures levels could have continued to rise even further

^a Additional information obtained from authors.

Study: Farrington *et al.*, 1998⁹¹ **Design:** Retrospective ITS (2 phases)
Setting: Tertiary hospital **Location:** East Anglia, UK **Dates:** 1985–97
Population characteristics: 1000 beds. ICT with one ICN. MRSA not endemic initially. About 1000 patients transferred from other hospitals per year (1996–7 data^a). Mean LOS: 7.82 (1994–5); 5.75 (1995–6); 5.38 (1997–8)^a
Stated aim of study: To describe 12 years of full surveillance and 1 year of very limited surveillance of MRSA
Major infection control changes during the study: Thresholds for ward closures and for reopening closed wards relaxed. Trigger for staff screening changed from 1 to 2 or 3 secondary cases on wards

	Isolation	Screening	Eradication	Other measures
Phase 1 10.5 years (1985–June 1995)	IW for MRSA patients and admissions with a history of or exposed to MRSA or recent significant exposure. Minimal overflow. Single rooms for patients awaiting screening results	Contacts of new MRSA cases screened 3 times in 10 days. Screening of patients at high risk of carriage on admission. ICU patients screened on admission and weekly ^a Staff at risk of carriage screened when recruited	Topical eradication (mupirocin and triclosan)	1. Ward transfers stopped when MRSA cases found 2. Gowns, gloves, masks 3. Ward closures
Phase 2 1.5 years (July 1995– 1997)	As for phase 1 except overflow from isolation ward cohorted and isolated in single rooms	As phase 1 except screening of contacts of MRSA cases reduced to twice in 7 days. Staff screening delayed until 2–3 secondary cases	As phase 1	As phase 1 except: ward closure threshold higher; wards reopened after 2 instead of 3 negative screens in 7 days

Isolation details: 12-bed purpose-built ventilated IW with single-room beds. 151 side rooms available for patients awaiting screening results. Some MRSA patients temporarily cohorted with designated staff on three occasions in phase 1

Screening details: Patients at high risk of carriage defined as those with previous MRSA and (from 1993) previous inpatients outside the region in the last 3 months or previous inpatients in hospitals outside the UK. Staff at risk of carriage defined as those having worked in London or outside the UK in last 2 years or having worked in a hospital with MRSA. When specified, screening sites were nose and lesions only, with additional sites for patient contacts of MRSA cases (throat and high-risk carriage sites) and ICU patients and high-risk admissions (throat, perineum and manipulated sites)^a

Eradication details: Topical eradication included: chlorhexidine hairwash and dental gel, hexachlorophane dusting powder and vancomycin gargles (replaced by oral rifampicin and fusidic acid in phase 2). Clearance defined by three consecutive negative swabs in 3 weeks

Reported outcomes:

1. Incidence:

Total MRSA: 6-monthly figures reported throughout study (1985–96)

Infections: From 1989 to 1996 yearly MRSA bacteraemias, pneumonias and other infections reported

MRSA carriage on admission: 6-monthly figures reported except for 1996

MRSA acquisitions: 6-monthly figures reported except for 1996

Other denominators: From 1993 daily patient census and yearly number of blood cultures reported

Definitions: Infection: CDC 1988 definitions³¹¹ (up to 1993); HIS definitions³¹³ (from mid-1993).

Carriage on admission: cases with no plausible external source and a plausible local source considered to be new acquisitions. No distinction after 1996 due to predominance of a single clone

2. Point prevalence: No data

3. Trends: Time series shows that numbers with MRSA on admission and numbers of acquisitions were stable and low between 1985 and mid-1994 (ranges: 2–10 and 0–15 cases per 6 months, respectively). Both then increased each 6 months, from 20 and 43 in the second half of 1994, reaching 33 and 50 in the first half 1995 (end of phase 1). Numbers continued to rise to 53 and 80 in the second half of 1995 (phase 2). Total MRSA continued to increase in both halves of 1996.

MRSA bacteraemias showed a similar pattern: numbers stable between 1989 and 1994 (£2 cases per year), then increased to 12, 18 and 74 in the next 3 years.

No MRSA chest infections between 1989 and 1993, although 1, 7 and 5 such infections occurred in the next 3 years.

Between 1993 and 1997 total *S. aureus* bacteraemias increased each year (from 83 in 1993 to 182 in 1997) and the per cent due to MRSA increased from 2.4 to 40.7. Over this period the per cent of blood cultures yielding MRSA increased from 0.021 to 0.56, while the per cent yielding MSSA remained between 0.78 and 0.88 throughout

4. Secondary outcomes: See Trends above

continued

Economic evaluation: Revised MRSA management reduced rate of ward closure from one ward per 30 days (first half of 1995) to one per 98 days (second half of 1995) and one per 72 days (1996)

MRSA strain details: Many MRSA strains before the second half of 1994 including six EMRSA admissions reported from Jan. 1992 to autumn 1994. From 1994 EMRSA-15 and EMRSA-16 accounted for about 60 and 30% of all MRSA

Analysis in paper: No statistical analysis of time series data

Major confounders and bias: Change in MRSA strains with which the hospital was challenged. Staffing and workload assessed in another paper⁸⁶

What the authors conclude:

1. The control policy eradicated multiple introductions and small outbreaks of MRSA over a 10-year period
2. Rising numbers of patients colonised on admission made control policy impossible to maintain and was followed by more transmission
3. Relaxing the control policy was associated with an uncontrollable rise in MRSA

Assessment of authors conclusions:

1. Conclusion is supported by data
2. Association is supported by data. Equally, increasing transmission was followed by increasing MRSA admissions
3. It is not clear from the data what, if any, effect the relaxation in the control policy had on MRSA spread. The increases in the numbers carrying MRSA on admission and in secondary cases were evident 1 year before the change in control measures. No change in the ratio of secondary cases to MRSA admissions was seen after the changes

^a Additional information obtained from authors.

Study: Girou *et al.*, 1998^a**Design:** Prospective time series (one phase)**Setting:** Medical ICU in university hospital**Location:** Paris, France**Dates:** 1993–6

Population characteristics: 26 beds in MICU, in 2 contiguous wards. 1032 beds in hospital. 3686 patients in unit during study (~900 admissions/year). Mean patient days per year in unit: 7000. Mean age (SD): 50.7 (19). About half the admissions came from the emergency department, the rest from other wards. MRSA initially endemic (MRSA reached 40% of all *S. aureus* isolates by early 1990s). ICT^a

Stated aim of study: To evaluate a control programme including screening for MRSA carriage and patient isolation

Major infection control changes during the study: No major changes. Minor changes to culturing and screening

	Isolation	Screening	Eradication	Other measures
Phase I 4 years (1993–6)	Single rooms or cohorting on closed bays with designated staff	Weekly screens for patients with prolonged stays. Patients at high risk of carrying MRSA screened on admission	Topical eradication from patients (mupirocin and chlorhexidine)	1. Handwashing education 2. Barrier nursing (gloves, gowns, masks)

Isolation details: Two contiguous wards. Ward 1: acute care unit with 4 2-bed subunits and 1 5-bed isolation room. Ward 2: intermediate care unit with 5 2-bed rooms and 3 single-bed rooms. All rooms with controlled ventilation

Screening details: Patients at high risk included: those with previous MRSA; transfers from wards with high levels of MRSA; patients with major surgery in last 5 years. Screening sites included nose and, before mid-1995, perineum and axillae

Eradication details: Clearance defined by two negative swabs 1 week apart^a

Reported outcomes:**1. Incidence:**

	1993	1994	1995	1996
Total new cases of MRSA identified (% of new admissions)	82 (10.1)	71 (8.1)	65 (7.2)	75 (6.9)
Number carrying MRSA on admission (% of new admission)	35 (4.3)	33 (3.8)	35 (3.9)	47 (4.3)
Total numbers acquiring MRSA on ICU (% of new admission)	47 (5.8)	38 (4.3)	30 (3.3)	28 (2.6)
Numbers with MRSA infections on admission	17	25	17	15
Number of MRSA positives on admissions acquiring MRSA infections	5	1	1	1
Number of MRSA negatives on admission acquiring MRSA infection	28	20	14	9
Denominator: no. of admissions/year	811	875	908	1092

Definitions: Infections: MRSA isolated from clinical diagnostic samples

MRSA carriage on admission: Positive isolates taken within 72 h of admission considered to indicate patient was positive on admission

2. Point prevalence: No data

3. Trends: No further data

Economic evaluation: None

MRSA strain details: None given

Analysis in paper: No appropriate analysis (rates over time were compared with the χ^2 test for trend)

Major confounders and bias: Annual admissions increased by 35% during study, suggesting either a decrease in LOS or increase in bed occupancy. Both could be important confounders, and the former could plausibly reduce the chance of detecting infections during patient stays. Impossible to assess whether there was a decreasing trend before the intervention. Control programme was introduced in response to increase in MRSA numbers in early 1990s so regression to mean effects are possible

What the authors conclude:

1. The MRSA acquisition rate decreased despite high exposure to imported cases
2. Admission screening in high-risk areas allows early detection of a large proportion of cases when MRSA is endemic. Without screening > 1/3 carriers would not have been found and 1/3 ignored for several days

Assessment of authors' conclusions:

1. Detection rate of ICU-acquired MRSA cases decreased, but increasing annual admissions suggest a decreasing LOS, and this would represent a major confounder
2. For this setting, the data support this conclusion

^a Additional information obtained from authors.

Study: Girou *et al.*, 2000⁹³ **Design:** Prospective before- and after-study
Setting: Dermatology ward **Location:** Paris, France **Dates:** 2 Sept. 1996–31 Dec. 1997
Population characteristics: 16 beds (14 standard + 2 intensive care side rooms). 729 patients during study. MRSA endemic. ICT
Stated aim of study: To evaluate the sensitivity of a targeted screening programme. To compare two strategies for screening for MRSA carriers in a high-risk dermatology ward (systematic screening of all versus targeted screening of patients at risk)
Major infection control changes during the study: Admission screening policy changed

	Isolation	Screening	Eradication	Other measures
Phase 1 8.5 months (2 Sept. 1996–19 May 1997)	Single room isolation and cohorting in 3-bed rooms for overflow	Patients at high risk of carrying MRSA screened at admission Patients staying ≥ 7 days screened weekly	None	Gloves and gowns
Phase 2 7.5 months (20 May 1997–31 Dec. 1997)	As phase 1	All patients screened on admission Patients staying ≥ 7 days screened weekly	As above	As above

Isolation details: Single-room isolation also for patients at high risk of importing or acquiring MRSA. Isolation ended for high-risk importers after negative screens. 10 single-bed rooms

Screening details: High-risk MRSA importers comprised: previous inpatients in last 3 years; transfers from other ward; patients with chronic skin lesions. Admission screens within 48 h. Sites screened: nose, perineum lesions

Eradication details: No eradication, though chlorhexidine baths used for all MRSA carriers^a

Reported outcomes:

1. Incidence:

Infections: No data

Colonisation: No data

MRSA carriage on admission:

	Phase 1	Phase 2
Number of admitted patients	370	359
Number of admitted high-risk MRSA importers	120	158
Number with admission screens	111	325
Number of high-risk MRSA importers with admission screens	92	147
Number with imported MRSA detected by admission screens	24	26
Number with imported MRSA detected by clinical samples	1	1
Number of high risk MRSA importers with imported MRSA	25	27

MRSA acquisitions: 10 in phase 1; 8 in phase 2

Definitions: MRSA carriage on admission: positive swabs taken within 72 h of admission

2. Point prevalence: No data

3. Trends: No data

Economic evaluation: No costing, but MRSA yield per admission screen in two phases compared: 21.6% (phase 1), 8.0% (phase 2), $p = 0.0001$

MRSA strain details: None

Analysis in paper: χ^2 test used to compare total imported MRSA cases in the two phases ($p = 0.69$). No analysis of acquisitions

Major confounders and bias: For evaluating sensitivity of screening programme design is vulnerable to trends and seasonal effects. For evaluating effects of intervention on MRSA control, screening is itself a confounder owing to lack of infection data

What the authors conclude: In areas with high-level endemic MRSA, targeting screening for MRSA carriage to patients with risk factors is an effective strategy

Assessment of authors' conclusions: Study suggests that yield of admission screening is substantially increased by screening only high-risk patients. A slightly higher acquisition rate was observed during phase 1 (selective screening), but the data presented do not allow formal analysis of the significance of the change. The power to detect a change in transmission rate is likely to be low. Potentially important confounders also exist

^a Additional information obtained from authors.

Study: Harbarth *et al.*, 2000,⁹²
Pittet *et al.*, 2000⁸⁰

Design: Hybrid retrospective (before 1994) and prospective (after 1994) ITS

Setting: 1300–1600-bed teaching hospital

Location: Geneva, Switzerland

Dates: 1989–97

Population characteristics: Number of beds: 1600 in early 1990s; 1400 in mid-1990s; 1300 in late 1990s^a. MRSA initially epidemic, later became endemic. ICT with 5 full-time ICNs from Oct. 1992. Number of patients during study: 50,6012. Mean age of MRSA patients (SD): 68 (23) years

Stated aim of study: 1. To evaluate consequences of delayed outbreak containment during a 4-year absence of control.
2. To describe the effect of a hand-hygiene programme on compliance and HAI

Major infection control changes during the study: Carer hand-hygiene education and feedback; patient isolation; screening; MRSA eradication; antibiotic use; automatic readmission alerts, disinfection, sterilisation, air control and building construction

	Isolation	Screening	Eradication	Other measures
Phase 1 48 months (Jan. 1989– Dec. 1992)	None	None	None	No MRSA control measures
Phase 2 24 months (Jan. 1993– Dec. 1994)	1. Single room 2. Cohorting on closed and open bays in special circumstance (e.g. unit-specific outbreaks)	1. Admission screens for previous MRSA patients 2. Contacts screened 3. Treated MRSA patients: weekly for 4 weeks, then monthly	Mupirocin and chlorhexidine Mupirocin used for almost all patients, irrespective of MRSA carriage ^a	1. CDC guidelines 1983 ³¹⁴ 2. Computer alerts for readmitted MRSA patients (July 1994 on)
Phase 3 36 months (Jan. 1995– Dec. 1997)	As phase 2	As phase 2	As phase 2 until Sept. 1997	As phase 2 + staff hand-hygiene education and feedback programme

Isolation details: From 1993 single rooms may not have been used when there was nasal carriage only and lack of available rooms. Contact for overflow with nasal carriage only. 60 single rooms available for acute services patients (without negative pressure)

Screening details: Screening sites: nose, lesion, groin, infected sites. Patients in 'septic' orthopaedic ward screened on admission from July 1994

Eradication details: From phase 2 most patients received ≥ 1 nasal mupirocin courses, irrespective of MRSA carriage^a. After Sept. 1997 mupirocin was limited to those with known nasal carriage and without chronic skin lesions and indwelling devices

Criteria for eradication: 2 negative sets of cultures ≥ 24 h apart

Reported outcomes:

1. Incidence:

Total MRSA: 1771 new MRSA cases from 506,012 admitted patients over whole study. Annual number of newly identified MRSA patients per 100 admissions reported over whole study ('attack rate'). Annual number of MRSA patients per 100 admission (i.e. including previously identified patients) reported over whole study ('prevalence'). Monthly data reported for 1989–95.¹⁴⁰ New cases per 1000 patient days reported

Infections: Annual incidence of bacteraemias reported over whole study (1989–97). Total MRSA infections per 10,000 patient days: 2.16 in 1994; 0.93 in 1998

Colonisation: No data

Carriage on admission: Initial colonisation status of readmitted known MRSA-positive patients recorded July 1994–June 1995. 114 of 347 (32.9%) were MRSA positive

Attributable deaths: No data

Denominators (in addition to those above): Number of screening cultures.

Note: only one isolate per patient per year was included in all the laboratory-based surveillance results

Definitions: Infection: CDC criteria.³¹¹ MRSA in urine cultures considered infections only if antibiotics given.

Carriage on admission: reported positive swabs ≤ 72 h post-admission, unless indications to the contrary

2. Point prevalence: No data on point prevalence among hospital population, although 'prevalence data' reported for population of patients admitted to the hospital over yearly intervals. See above

3. Trends:

1. Newly identified MRSA patients per 100 admissions initially very low (0.05 in 1989), increasing yearly to 0.57 in 1992 (end of phase 1), 0.49 in 1993 and 0.6 in 1994. Subsequently fell each year to reach 0.24 in 1997

continued

2. Cases per 1000 patient days showed a similar pattern, as did MRSA bacteraemias (1 in 1989, peaking at 34 in 1992, then falling each year after 1994 to reach 10 in 1997)

3. Total number of MRSA patients per 100 admissions (including previously identified patients) followed a similar pattern of rise and fall (from 0.07 in 1989, peaking at 1.42 in 1994, and falling to 0.59 in 1997), but the eventual fall occurred somewhat later than that of the other measures. Percentage of MRSA among laboratory isolates also exhibited this lag

4. Secondary outcomes:

1. *Hand-hygiene compliance:* 6-monthly surveys of compliance rates (Dec. 1994–Dec. 1997). Compliance rose from 47.6% (Dec. 1994) to 53.4 (Dec. 1995) to 61.8% (Dec. 1996) to 66.2 (Dec. 1997). Volumes of alcohol handrub used also increased

2. *MRSA:MSSA:* Annual figures for MRSA as a per cent of total laboratory *S. aureus* isolates reported for whole study (1989–97). MSSA bacteraemias also reported. There was no apparent trend in annual MSSA bacteraemias (range: 78–102)

Economic evaluation: Cost estimates for microbiology, surveillance, contact isolation. Total infection control programme estimated to have cost almost SF 3–4 million to the institution

MRSA strain details: Not reported in papers considered here but PFGE typing.¹⁴⁰ Spread due to several epidemic strains

Analysis in paper: Poisson regression used to analyse changes of incidence. Details of regression model not presented

Major confounders and bias: Changes in length of patient stays and bed occupancies. Some account is taken of these by appropriate choice of denominators, but shorter length of stay may reduce detection of infections

For outcomes that include patient colonisation, changes in screening practice and effort represent major confounders, but MRSA bacteraemia data should not be affected by this

What the authors conclude:

1. Infection control measures had a big impact on the MRSA reservoir and bacteraemia attack rate

2. Findings confirm reports of the value of hand-hygiene for MRSA transmission control (although study design precludes ascertainment of the proportion of the reduction in the infection rate attributable to the hand-hygiene campaign)

3. Hand-hygiene programme produced a sustained increase in compliance, coinciding with a reduction of MRSA transmission

Assessment of authors' conclusions:

1. The data provide clear evidence that the number of patients with MRSA and MRSA bacteraemias first stabilised and then fell after control measures were implemented. The assertion that the control measures caused the change is highly plausible, although there are some potentially important confounding factors

2. It is not possible to tell what effect any single measure had, although the fall in new cases after 1995 is consistent with the assertion that reported improved hand-hygiene compliance played an important role

3. Plausible evidence that hand-hygiene programme improved hand-hygiene compliance in a sustained manner

HAI, hospital-acquired infection; SF, Swiss Francs; PFGE, pulsed field gel electrophoresis.

^a Additional information obtained from authors.

Study: Hartstein *et al.*, 1997¹⁰⁸ **Design:** Non-comparative prospective observational study in two hospitals
Setting: Two teaching hospitals **Location:** Indiana, USA **Dates:** June 1993–Nov. 1994
Population characteristics: Hospital A: endemic MRSA. Mean daily patient census ~280 (1993), ~250 (1994).
Hospital B: endemic MRSA. Mean daily patient census ~230 (1993), ~250 (1994). Hospitals share physicians and house staff
Stated aim of study: To describe control of endemic and outbreak related MRSA at two affiliated hospitals
Major infection control changes during the study: None. Policy was for 'progressive interventions' until control was established in an outbreak situation. Policy itself did not change

	Isolation	Screening	Eradication	Other measures
Hospital A				
Phase I 18 months (June 1993– Nov. 1994)	Single rooms	None	Topical eradication with mupirocin for selected patients only (<5% of MRSA patients)	Gloves. Handwashing education. PFGE typing of isolates to allow reinforcement of policies
Hospital B				
Phase I 18 months (June 1993– Nov. 1994)	Single rooms	None	As above	As above

Isolation details: Isolation continued until eradication achieved. Discontinued for <5% of MRSA patients before discharge

Screening details: No screening (apart from to determine eradication)

Eradication details: Unspecified oral antimicrobials also sometimes used for eradication of MRSA colonisation.

Eradication criteria: patient off potentially suppressive antimicrobials and culture negative in nose and previously positive sites

Reported outcomes:

1. Incidence:

Total MRSA: Monthly incidence of total hospital-acquired MRSA cases reported

Infections: Infection details reported only for outbreaks and pseudo-outbreaks

Denominators: None reported

Colonisation: No data

MRSA carriage on admission: Hospital A, 60; Hospital B, 36

MRSA acquisitions: Hospital A, 48; Hospital B, 22

Definitions: Infections: CDC guidelines 1988.³¹¹

MRSA carriage on admission: positive swabs within 48 h of admission.

Clusters of cases characterised as outbreaks (≥ 3 hospital-acquired cases of isolates amongst patients cared for by same clinical service, where strains' PFGE profiles differed by 3 bands or fewer). Pseudo-outbreaks were similar clusters where strains had different PFGE types

2. Point prevalence: No data

3 Trends: No time series for numbers carrying MRSA on admission at either hospital.

At hospital A, numbers of hospital-acquired cases showed some evidence of a reduction with time, although monthly numbers of cases were small (0–7). Only two outbreaks (as defined above) occurred, affecting 4 and 3 patients

At hospital B, monthly hospital-acquired cases remained in the range 0–3 throughout the study, with only one outbreak, affecting 5 patients

Economic evaluation: Costings for PFGE typing reported (labour and materials)

MRSA strain details: 39 PFGE types at hospital A, 31 at hospital B (12 types common to both hospitals). At hospital A one type caused 14 'community acquired' cases, and 13 nosocomial. Otherwise no isolate caused >5 nosocomial cases

Analysis in paper: None

Major confounders and bias: Without screening the importance of MRSA transmission may be underestimated
What the authors conclude: MRSA in hospitals can be controlled by minimal precautions and interventions despite continuous admission of patients carrying MRSA

Assessment of authors' conclusions: The data provide some support for the conclusion that **some** MRSA strains can be controlled in **some** hospitals with minimal precautions as there are no large clusters of strains with the same PFGE types. However, lack of screening means the full extent of transmission and therefore control cannot be assessed, and it is not clear if control in the longer term would be achieved (for example, it is possible that there is sufficient transmission to allow the total MRSA reservoir to increase, resulting in increased numbers carrying MRSA on admission). Impossible to tell from this study whether control measures contributed to prevention of spread

Study: Jernigan *et al.*, 1996⁹⁵ **Design:** Hybrid prospective and retrospective ITS (2 phases). Phase 1 retrospective, phase 2 prospective

Setting: NICU

Location: Virginia, USA

Dates: 18 July 1991–11 May 1992

Population characteristics: 33 beds, MRSA not endemic. ICT with 4 ICNs for 700 hospital beds.

331 patients admitted during the first 7 months of study. NICU admits ~700 patients/year

Stated aim of study: To compare the rate of transmission from unisolated patients with the rate from MRSA-positive patients in contact isolation

Major infection control changes during the study: Changes to handwashing, MRSA eradication and screening

	Isolation	Screening	Eradication	Other measures
Phase 1 12 days (18 July–29 July 1991)	Contact isolation (CDC Guidelines 1983) ³¹⁴	Contacts of MRSA cases	None	Contact isolation included: gloves, gowns, mask
Phase 2 ~9 months 30 July 1991–11 May 1992	As phase 1	As phase 1 + All patients screened weekly HCW contacts screened once	Attempted for colonised staff and selected patients	As above + Handwashing education

Isolation details: One 2-bed isolation area used for the isolation of some MRSA patients, although often unable to accommodate all MRSA patients

Screening details: Screening sites: nose, axillae, groin, wounds, percutaneous devices. 'Contacts of MRSA patients' were taken to be room-mates and nearby patients considered to be at risk. Nose and wound screens only for staff

Eradication details: Attempted in 10/16 patients, succeeded in 7. Topical mupirocin used predominantly. Also used: chlorhexidine baths and systemic eradication with vancomycin, TMP/SMX, rifampicin. Eradication regimen selected by primary physician

Reported outcomes:

1. Incidence:

Total MRSA: 16 patients colonised or infected. 5 cases in phase 1; 11 in phase 2. Estimated acquisition times reported

Infections: 3 infections including one bacteraemia

Colonisation: 13 colonised patients

MRSA carriage on admission: Index case presumed to have been colonised on admission

MRSA acquisitions: 15 cases acquired on ward. 0.17 transmissions per colonised patient week

Denominators: 331 neonates admitted during the first 7 months of the study (when all the transmission occurred)

Definitions: Infection criteria: not specified.

MRSA carriage on admission: all strains of common outbreak type assumed to be true acquisitions (except index case)

2. Point prevalence: Weekly prevalence reported throughout study

3 Trends: Incidence of new cases was very high in phase 1 (4 acquisitions in 12 days), and fell sharply in phase 2 (despite a cluster of 3 cases in late Nov./early Dec.). Prevalence rose rapidly after initial cluster of cases in phase 1, reaching 7 in early Aug. It then declined to reach 1 in Nov. Prevalence increased briefly to 4 with the Dec. cluster, but then fell back to 1 until the last case was discharged

4 Secondary outcomes: HCW MRSA carriage: 0/144 HCW cultures taken during the outbreak were positive for MRSA

Economic evaluation: None

MRSA strain details: All 16 isolates belonged to the same strain (based on plasmid analysis and RFLPs of whole-cell DNA)

Analysis in paper: Sources of transmission assessed by two independent observers based on temporal and spatial data, and information about shared HCWs (with 100% concordance), and transmission rates compared using the large-sample test for comparison of incidence rates. Rate of transmission for isolated source: 0.0090 transmissions per colonised patient day. For unisolated source: 0.14 transmissions per colonised patient day. Relative risk (95% CI): 15.6 (5.3 to 45.6), $p < 0.0001$

Major confounders and bias: No blinding of assessors of sources of transmission to the isolation status of patients means that there is a large potential for bias in these assessments. Intervention made because of the high numbers of transmissions in phase 1, so regression to mean may be important

What the authors conclude:

1. Patients rather than HCWs appear to be the main reservoir

2. The transmission rate from isolated sources is significantly greater than that from unisolated sources. Even if 5 transmissions were misclassified and were really from isolated patients the effect would have been significant

Assessment of authors' conclusions:

1. Evidence supports conclusion

2. Conclusion depends on accuracy of assumptions regarding the sources of transmissions. Since no blinding as to the isolation status of patients is reported, the results may be subject to large bias. Had such blinding been conducted the strength of the evidence would have been substantially greater. However, any change could still not be attributed solely to isolation; there were also changes in eradication therapy, and there are many potentially important confounders

TMP/SMX, trimethoprim/sulphamethoxazole; RFLP, restriction fragment length polymorphism.

Study: Jones and Martin, 1987¹⁰³ **Design:** Outbreak report. Retrospective ITS (3 phases)
Setting: Tertiary hospital **Location:** Wellington, New Zealand **Dates:** Mar. 1985–Dec. 1986
Population characteristics: ~750 beds.^a Mean age of patients with MRSA, 51.7; range, 7–94. MRSA not endemic
Stated aim of study: To describe the first significant MRSA outbreak known in New Zealand
Major infection control changes during the study: Patient isolation

	Isolation	Screening	Eradication	Other measures
Phase 1 ~10 months (late Mar. 1985–Jan. 1986)	Single rooms and cohorting	All HCW and patient contacts screened when clinical MRSA cases on high-risk wards	Eradication attempted whenever colonisation found in patients and HCWs	MRSA patients moved from high- to low-risk wards when possible Handwashing education
Phase 2 5 months (Feb.–June 1986)	IW	As phase 1	As phase 1	Handwashing education
Phase 3 6 months (July–Dec. 1986)	As phase 1	As phase 1	As phase 1	1. Previous MRSA patients isolated on readmission ^a 2. Handwashing education

Isolation details: Sufficient single rooms available (≥ 12) to isolate all MRSA patients.^a Some cohorting on 2–4-bed cubicles in phase 1.^a Designated carers for MRSA patients in ICU and renal unit, but otherwise NC found to be difficult when low MRSA numbers.^a IW in phase 2 had only 3 beds, but was able to accommodate all MRSA patients.^a IW staff not permanent, but remained there during each shift

Screening details: Screening sites: nose, perineum

Eradication details: Topical agents: chlorhexidine, hexachlorophene cream. Systemic eradication with rifampicin and fusidic acid for one carer. MRSA-positive staff taken off work until cleared, and screened weekly for 1 month on return

Reported outcomes:

1. Incidence:

Total MRSA: 29 inpatients colonised or infected during study: 21 cases in phase 1; 6 in phase 2; 2 in phase 3

Infections: 2 bacteraemias in phase 1

Colonisation: 27 patients with colonisation only

MRSA carriage on admission: 3 patients assumed to have been colonised on admission (2 in phase 1; 1 in phase 2)

MRSA acquisitions: 26 acquisitions assumed in study hospital

Attributable mortality: 2 deaths where MRSA septicaemia was a contributory factor

Definitions: Infection: authors considered it impossible to distinguish colonisation and infection precisely

MRSA carriage on admission: strains of common outbreak type assumed to be hospital-acquired

2. Point prevalence: Full data, as hospital stays of MRSA patients are reported: 0–3 cases

3. Trends: Incidence fairly constant for first months (0–2 cases/month), increasing in second half of phase 1, peaking at 5 cases in Jan. 1986. Only 2 new cases in phase 3 (in July 1986), with no more appearing for the rest of the period

4. Secondary outcomes: *HCW carriage:* 4 HCW carriers found during whole study. 0/140 screened rotating nurses colonised

Economic evaluation: None

MRSA strain details: One predominant strain: resistant to cotrimoxazole, clindamycin, erythromycin, tetracycline, all cephalosporins. Variable (plasmid-mediated) resistance to gentamicin and kanamycin.

Phage type 29,81,6,42E,47,53,54,75,83A, 55 (after heat shock)

Analysis in paper: None

Major confounders and bias: Large reporting bias may be expected with this type of study

What the authors conclude: Control methods appeared to have been effective in bringing the outbreak to an end

Assessment of authors' conclusions: Role of combined control measures in ending outbreak is plausible, but the time series is short, the number of cases is small and stochastic fadeout may not have been unlikely

^a Additional information obtained from authors.

Study: Kac *et al.*, 2000⁹⁷ **Design:** Prospective ITS (2 phases)
Setting: Wound care centre/vascular rehabilitation ward **Location:** Paris, France **Dates:** Sept. 1993–Dec. 1996. No data for 1995
Population characteristics: 51 beds. 817 patients during study. MRSA endemic. Mean LOS (for 1994 and 1996): 35 days. 350–400 admissions to unit per year. Unit dedicated to chronic ulcer care and vascular surgery wounds
Stated aim of study: To assess nosocomial MRSA acquisition and the effect of an intervention to control it
Major infection control changes during the study: Feedback of infection rates, staff handwashing, barrier nursing

	Isolation	Screening	Eradication	Other measures
Phase 1 3 months (Sept.–Nov. 1993)	None	All patients' skin wounds screened on admission. Wounds screened only if clinical worsening occurred	None	No special infection control measures
Phase 2 36 months (Jan. 1994–Dec. 1996)	Gowns and gloves only	As above	As above	1. Handwashing education 2. Feedback of MRSA infection rates 3. MRSA patients' wound dressings changed last 4. Notes of MRSA patients marked 5. Systematic use of disposable devices 6. Dressing change procedure modified

Isolation details: Gowns and gloves for staff with direct wound contact in phase 2

Screening details: No enrichment

Eradication details: No eradication

Reported outcomes:

Time series with three data points: Sept.–Nov. 1993, 1994 and 1996. No data collected for 1995

1. Incidence:

	Phase 1	Phase 2a (1994)	Phase 2b (1996)
MRSA carriage on admission/number swabbed:	18/88	65/334	81/395
MRSA acquisitions (wound infection)/number negative on admission	6/70	6/269	3/314
MRSA acquisitions (wound colonisation)/number negative on admission	No data	6/269	8/314
MRSA acquisitions (wound colonisation) per 1000 resident care days	No data	0.39	0.61
MRSA acquisitions (wound infection) per 1000 resident care days	No data	0.39	0.23

Definitions: Infection: CDC criteria 1988³¹¹ (clinical signs and pure MRSA cultures). Carriage on admission: detection within 48 h of admission

2. Point prevalence: No data

3. Trends: 3 data points only

Economic evaluation: None

MRSA strain details: No typing

Analysis in paper: No appropriate analysis (χ^2 and Fisher's exact test used to compare incidence data)

Major confounders and bias: Very short phase 1 baseline, and comparison between phases 1 and 2 vulnerable to seasonal effects. Lack of typing reduces certainty that acquisitions were from cross-infection. Those colonised on admission were excluded from the study, so unknown whether intervention reduced infection in these patients too

What the authors conclude:

1. There was a significant decrease in the wound infection rate between phase 1 and the postintervention years
2. Simple infection control measures seemed to reduce infection rates in patients with chronic skin breaks

Assessment of authors' conclusions:

1. There was a decrease in the MRSA wound infection rate, but insufficient data to assess its significance
2. Statement is plausible, although number in phase 1 is small, and it is possible that there was already a trend of reduced cross-infection prior to the interventions in phase 2. Data presented do not allow this to be assessed

Notes: There was no typing, and only wounds were screened on admission, therefore it is not possible to tell what proportion of new acquisitions resulted from cross-infection and what proportion from autoinfection, or how these were changed by the intervention. Intervention carried through in 1995 but no data collected or presented from that year

^a Additional information obtained from authors.

Study: Landman *et al.*, 1999⁵⁶ **Design:** Retrospective ITS (two phases). Comparison not suggested by data
Setting: Teaching hospital **Location:** New York, USA **Dates:** Jan. 1993–Apr. 1997
Population characteristics: MRSA initially endemic (39% of *S.aureus* isolates between 1993 and 1995)
Stated aim of study: To examine the effect of a change in the antibiotic formulary on nosocomial pathogens, including MRSA
Major infection control changes during the study: Antibiotic formulary changed

	Isolation	Screening	Eradication	Other measures
Phase 1 29 months (Jan. 1993– May 1995)	None	None	None	No specific precautions
Phase 2 23 months (May 1995– Apr. 1997)	None	None	None	No specific precautions. Cephalosporins, clindamycin and vancomycin use restricted with cephalosporins replaced by ampicillin/sulbactam and piperacillin/tazobactam

Isolation details: No isolation

Screening details: No screening

Eradication details: No eradication

Reported outcomes:

1. Incidence:

Infections: Monthly incidence of MRSA infections reported

Mean monthly incidence of new patients culture positive for MRSA per 1000 discharges (SD): 21.9 (8.9) for phase 1; 17.2 (7.2) for phase 2

Colonisation: No data

MRSA carriage on admission: No data

MRSA acquisitions: No data

Attributable mortality: No data

Denominators: per 1000 discharges

Definitions: Infection: all positive cultures of blood, other sterile body fluids, wounds, respiratory or urinary tracts

2. Point prevalence: No data

3. Trends: Time series of monthly incidences of MRSA infections shows wide variability (between 10 and 45 cases/month in phase 1, and about 10–40 cases/month in phase 2). Immediately after the intervention there was a big increase in the number of cases, followed by a bigger fall and a period of sustained lower level of infections, before later increases

4. Secondary outcomes: MRSA:MSSA: MRSA as a percentage of all *S. aureus* isolates: 39% for 1993–5 (2447 isolates); 35% for 1996 (678 isolates). Monthly use of 3 targeted antibiotics fell significantly and that of their alternative replacements rose significantly. Use of 4 untargeted antibiotics (imipenem, gentamicin, cefazolin and ceftazidime) fell significantly

Economic evaluation: Antibiotic costs per month US\$29,457 (phase 1), \$28,085 (phase 2)

MRSA strain details: No typing

Analysis in paper: No appropriate analysis. (Student's *t* and χ^2 tests used to compare pre- and postintervention data, and linear regression to examine correlations between MRSA incidence and number of discharges, LOS and antibiotic usage)

Major confounders and bias: Reduction in length of stay and monthly discharges are both important confounders, producing an estimated reduction in patient days between the two phases of over 20%

What the authors conclude: Following the formulary change there was a significant reduction in the monthly number of patients with MRSA. Altering the formulary may help contain the spread of resistant pathogens

Assessment of authors' conclusions: MRSA remained endemic after the intervention, although at a slightly lower level. No valid assessment of statistical significance of this decrease was presented. Length of stays and monthly discharges are important confounders. Altering formulary may control spread, but there was no attempt to determine numbers carrying MRSA on admission and no typing

Study: Law *et al.*, 1988¹⁵**Design:** Retrospective ITS (3 phases)**Setting:** General hospital**Location:** London, UK**Dates:** July 1985–Dec. 1987**Population characteristics:** ~400 beds, 14 acute wards. MRSA not initially endemic. ICT^a (1 ICN)**Stated aim of study:** To report the success of rigorous control measures in an extensive MRSA outbreak**Major infection control changes during the study:** Patient isolation, eradication therapy, screening

	Isolation	Screening	Eradication	Other measures
Phase 1 12 months (July 1985– June 1986)	None	Patients on acute wards screened prior to transfer to new building at end of phase	None	2 weeks before end of phase admissions curtailed. At end of phase acute beds moved to new building
Phase 2 3 months (July 6– Sept. 1986)	2 IWs. Single rooms used for ICU MRSA patients	HCWs and patients on unemptiable MRSA-contaminated wards screened every 3 days until 2 consecutive negatives for whole ward, and after ward cleaning. HCWs on MRSA-contaminated wards screened when wards closed for cleaning	Topical eradication for patients and staff	1. Control based on 1986 UK guidelines ⁴⁰ 2. Contaminated wards amalgamated when possible, and closed wards cleaned 3. Staff movement between wards restricted
Phase 3 15 months (Oct. 1986– Dec. 1987)	Single rooms (during minor outbreaks and for patients having been in hospitals with MRSA in last 3 months). NC when possible, but incomplete ^a	Contacts of MRSA patients (patients and HCWs) Patients having stayed in hospitals with MRSA in last 3 months screened on admission	As phase 2	Control measures reinstated during 'minor outbreaks'

Isolation details: Phase 2 IWs were converted normal wards, with sufficient beds to accommodate all MRSA cases.^a MRSA patients identified by screening in phase 1 transferred straight to isolation ward in phase 2. Exposed patients screening negative in phase 1 were moved to wards designated as 'contaminated'. New patients in phase 2 admitted to a contaminated ward only if it had been declared 'cleared' (i.e. MRSA free) as a result of 2 sets of negative whole-ward swabs

Screening details: Screening sites (phase 1): nose, lesions, groin, CSU, wound, hairline, i.v. sites

Eradication details: Agents used: Naseptin (neomycin and chlorhexidine). Mupirocin and povidone iodine used for skin lesions. Clearance defined by three negative screens

Reported outcomes:

1. Incidence:

Total MRSA: Phase 1: Isolates of epidemic strain from 77 patients (other strains from 5 patients)

Infections: 40 infections in 37 patients, including 7 bacteraemias, presented as a time series of quarterly totals

Colonisation: See **Point prevalence**

Attributable mortality: 3 (all in phase 1)

Definitions: Infection: detailed criteria specified

2. Point prevalence: Presence of MRSA colonisation in patients on acute wards plotted against duration of admission for end of phase 1, and 7 months after the intervention (end of phase 3). In phase 1 prevalence increases steeply with stay (49 of 95 patients in acute wards for > 10 days were colonised). At the end of phase 3 there is little evidence of any such increase (only 4 of 124 patients with stays > 10 days were colonised)

3. Trends: Number of patients with MRSA infections increased in phase 1 (from 5 in first quarter to 15 in the last), and fell sharply following the intervention to 1–4 per quarter in phase 3. No attributable deaths followed the intervention

4. Secondary outcomes: MRSA:MSSA: Phase 1: 24% of all *S. aureus* strains were MRSA

HCW MRSA carriage: No. positive/no. screened: 20/100

Economic evaluation: No costs data, but ward closure to waiting list and emergency admissions for 5 weeks as no 'clean wards'

MRSA strain details: Almost all South-East England 'epidemic' strains: untypeable with international phages, but lysed by experimental phages 88A and 932

Analysis in paper: No appropriate analysis of incidence data (χ^2 test used)

continued

Major cofounders and bias: Change to new building for acute beds in phase 2 associated with a number of confounding factors unrelated to control measures, e.g. less crowding, better handwashing facilities, environmental cleanliness

What the authors conclude:

1. Rigorous measures controlled the outbreak despite its extent
2. Local outbreaks were controlled by reinstating control measures

Assessment of authors' conclusions:

1. Conclusion is plausible, as there is sharp drop in the number of infections immediately following the intervention. However, there are many possible cofounders
2. This is plausible, but it has not been shown that outbreaks would have been uncontrolled without the measures in the new building

^a Additional information obtained from authors.

Study: Linnemann *et al.*, 1982⁹⁶ **Design:** Retrospective ITS (4 phases)
Setting: University hospital **Location:** Cincinnati, OH, USA **Dates:** Mar. 1977–Mar. 1981
Population characteristics: 600 beds with all major medical and surgical specialties except paediatrics. Burns unit on surgical unit with shared nursing staff. MRSA became endemic. ICT with 2 ICNs
Stated aim of study: To report the epidemiology and control measures taken for an MRSA outbreak
Major infection control changes during the study: Patient isolation

	Isolation	Screening	Eradication	Other measures
Phase 1 15 months (Mar. 1977– May 1978)	Cohorting in 2-bed rooms or single rooms	HCWs screened when clusters of cases	Eradication from persistent staff carriers	Staff education
Phase 2 6 months (June 1978– Nov. 1978)	IW	As phase 1	As phase 1	1. National CDC guidelines ³¹⁵ 2. Chronic staff carrier removed at end of July
Phase 3 6 months (Dec. 1978– May 1979)	Cohorting on closed bays or single rooms	As phase 1	As phase 1	Masks
Phase 4 23 months (June 1979– Mar. 1981)	As phase 1	As phase 1	As phase 1	1. Category-specific precautions ³¹⁵ 2. Sept. 1979: trauma service disbanded and patients admitted throughout surgical wards 3. Feb. 1980: burn service moved from surgical unit to a new self-contained unit

Isolation details: Phase 1: no overflow^d. In phase 2 IW had 33 beds; bed occupancy in IW was low (66% in June 1978, 42% in Nov. 1978), but occasionally overflow cohorted in open bay on ICU. During the study all 5-bed rooms (accounting for ~70% of beds) were converted to 2-bed rooms

Screening details: Sites screened: nose only for HCWs

Eradication details: Topical agent: bacitracin

Reported outcomes:

1. Incidence:

Infections: Monthly time series of numbers of patients infected with MRSA strains also resistant to gentamicin. Quarterly number of infections per 1000 discharges. Annual MRSA bacteraemias

Colonisation: Attack rate (% of patients colonised) reported for different groups for whole study: burns (19%); trauma (2%); general surgery (1%); medical patients (0.2%)

MRSA carriage on admission: No data

Attributable mortality: No data

Definitions: Infection: CDC criteria 1971.³¹⁶ Carriage on admission: positive swab ≤ 48 h after admission

2. Point prevalence: No data

3. Trends: Infection incidence ≤ 1 case/month before Sept. 1977, then increased sharply, peaking at 13 cases/month in Mar. and May 1978. Incidence decreased slightly at start of phase 2 (mean, 7.5; range, 2–11); was stable during phase 3 (mean, 6.2; range, 5–7); then exhibited large fluctuations in phase 4 (range, 0–15), eventually decreasing to single cases in the last 2 months. MRSA bacteraemias increased in each of the first 3 years (from 0 to 1.2 per 1000 patients), and fell to 0.6 in the last

4. Secondary outcomes: MRSA:MSSA: MSSA bacteraemias reported annually. Numbers of MSSA bacteraemias were stable for the first 2 years (4.5/1000 patients), fell slightly over the next 2 years (to 3.8 and 3.5) and increased slightly in 1980 (to 4.0). Total number of *S. aureus* bacteraemias remained almost constant

HCW carriage: 9/432 (2%) of staff were carriers over whole study

Economic evaluation: Unoccupied IW beds estimated to cost US\$460,585 for 6 months. Unfilled beds in phase 3 cost \$199,600 for 6 months. Costs represent reimbursement that would have been received had these beds been occupied

continued

MRSA strain details: One predominant strain: uniformly resistant to cephalothin, gentamicin, tobramycin. No change in phage type over 4 years: 51% of isolates were D11/83A, 33% D11/83A/85

Analysis in paper: No analysis of time series data

Major confounders and bias: Physical changes to hospital design from 5- to 2-bedded rooms. Burns Unit (which had highest rate MRSA) moved to self-contained unit. Lack of screening means that changes in numbers positive on admission would not have been detected, and their contribution to changes in incidence of infection, unknown

What the authors conclude:

1. The organism could be contained by an IW and then side-room isolation but not eliminated
2. The burns unit appeared to be a significant factor in the control of the epidemic as was conversion from 5- to 2-bed rooms
3. MRSA tended to replace MSSA as a cause of infections rather than add to the burden of infections

Assessment of authors' conclusions:

1. Conclusion is supported by MRSA infection but not bacteraemia data. Lack of prevalence and carriage on admission data makes interpretation difficult
2. Decline in numbers following relocation of burns unit is consistent with a causal relationship. No data on timing of rooms conversions
3. Conclusion is supported by the bacteraemia data

Notes: There is some ambiguity as to whether the opening of the burns unit and change in number beds per room are interventions or confounders. They are considered as confounders here based on the reporting of the study

^a Additional information obtained from authors.

Study: Lugeon *et al.*, 1995¹⁰⁴ **Design:** Prospective observational study (uninterrupted time series)
Setting: University hospital **Location:** Lausanne, Switzerland **Dates:** Jan. 1989–Dec. 1992

Population characteristics: 1000-bed hospital, with ~30,000 admissions/year

Stated aim of study: To use ribotyping to investigate the epidemiology of MRSA over 4 years

Major infection control changes during the study: No major changes. Minor changes in topical eradication. Policies for screening and isolation stayed the same throughout the study, though the policy was for both to change when clusters were found

	Isolation	Screening	Eradication	Other measures
Phase I 4 years (Jan. 1989– Dec. 1992)	Single rooms for known and readmitted MRSA patients awaiting screening results. Cohorting when ≥ 3 cases on unit. ^a Nurse cohorting only when ≥ 4 cases on unit ^a	Patients with previous MRSA on readmission. Patient contacts of MRSA patients, and staff contacts when clusters found (≥ 2 cases of same type in same unit)	Eradication attempted whenever MRSA detected in patients or HCWs	Gloves, gowns, masks (strict isolation for staff and visitors)

Isolation details: 4 single rooms per unit^a (6% of MRSA patients had no isolation measures). Control measures implemented for ≥ 7 days and isolation stopped when MRSA cleared

Screening details: Sites screened: nose, axillae, groin, wounds

Eradication details: Topical agents: chlorhexidine + bacitracin (1989 only); mupirocin (since 1990). Systemic agents: cotrimoxazole + rifampicin. Treatment repeated if failed first time, and maintained if it still failed. Clearance defined by 2 negative screens, the first being ≥ 2 days post-treatment

Reported outcomes:

1. Incidence:

Total MRSA: 125 patients were colonised or infected with MRSA over the study (including 18 outpatients). Time series reports monthly incidence of MRSA cases and clusters of ≥ 3 cases caused by the same strain

Infections: 25 patients with MRSA infection, including 3 bacteraemias and 5 pneumonias

Colonisation: 100 patients with MRSA colonisation only over whole study

Carriage on admission: 10 of 19 screened readmitted patients previously identified as MRSA carriers were positive on readmission. 25 patient MRSA cases considered 'community acquired'

MRSA acquisitions: Epidemiological links (patients with same strain type on same unit at same time) reported to have been found for 80 of 122 MRSA cases assessed. 13 'breakthrough cases' (initially MRSA-negative patients who became positives despite implementation of control measures for known cases on unit)

Denominators: None given

Definitions: Infection: None given, but only deep infections requiring vancomycin treatment included in above figures

Carriage on admission: Positive swabs within 48 hours of admission, and no other sources on ward

2. Point prevalence: No data

3. Trends: Pattern of spread characterised by 14 clusters of related cases of limited duration (the longest being 9 months) and 42 sporadic cases not leading to secondary spread. No clear trends, although there is perhaps a tendency for smaller and more infrequent clusters towards the end of the study

4. Secondary outcomes: MRSA:MSSA: Percentage of MRSA amongst *S. aureus* isolates fell from 4.2% in 1989 and 1990 to 2.2% in 1992

HCW carriage: 4 cases of MRSA carriage amongst 489 staff from whom 701 specimens were taken

Economic evaluation: None

MRSA strain details: 122 isolates recovered from 122 patients were distributed into 26 ribotypes. 9 types were recovered from more than one patient. 7% of strains were resistant to cotrimoxazole, 33% to rifampicin. None were mupirocin resistant

Analysis in paper: None

Major confounders and bias: Estimates of proportions of cases that are imported and newly acquired will be vulnerable to lack of discriminatory power or reproducibility of typing (although both were reported to be high)

What the authors conclude:

I. New strains were introduced regularly from outside sources, and community MRSA may be a significant source. Staff carriage was not the main source

continued

2. Ribotyping helped to spot clusters and to focus infection control efforts
3. Spread was limited at least in part by the infection control programme, although attempted eradication was often ineffective

Assessment of authors' conclusions:

1. Typing data support this conclusion, and the conclusion that staff carriage was low (although data do not allow an assessment of the relative importance of different sources)
2. Ribotyping appears to have helped identify clusters, but no comparison was made with alternative typing methods. Lack of stability of ribotypes within single lineages and lack of discriminatory power are both threats to the validity of the conclusions, but authors report high reproducibility and discriminatory power although ribotyping generally has poor discrimination compared to PFGE. Not possible to assess how important ribotyping was for control
3. Not possible to assess role of control measures in preventing spread from supplied data

^a Additional information obtained from authors.

Study: Mayall *et al.*, 1996¹¹⁹

Design: Prospective ITS (4 phases)

Setting: Thoracic medical and surgical ward **Location:** Melbourne, Australia **Dates:** 14 Dec. 1992–17 June 1994

Population characteristics: 35 beds in ward. Ward based in a 500-bed teaching hospital. MRSA initially endemic in ward. Mean age of MRSA patients: 72.2 years (range: 47.3–85.0). ICT

Stated aim of study: To describe experience of controlling an outbreak of MRSA with intranasal mupirocin in a thoracic ward with endemic MRSA

Major infection control changes during the study: Screening, patient isolation, topical eradication, handwashing education

	Isolation	Screening	Eradication	Other measures
Phase 1 49 days (14 Dec. 1992–31 Jan. 1993)	NC	All patients screened on admission and twice weekly. HCWs screened once	Mupirocin for all patients regardless of MRSA status (3 times/day for 3 days, then 3 times/week)	Handwashing education
Phase 2 45 days (1 Feb.–17 Mar. 1993)	None	All patients screened on admission and twice weekly	Mupirocin for all patients regardless of MRSA status (on admission, then 3 times/week)	As phase 1
Phase 3 92 days (18 Mar.–17 June 1993)	None	All patients screened on admission and weekly	Mupirocin for all patients regardless of MRSA status (on admission, then weekly)	As phase 1
Phase 4 365 days (18 June 1993–17 June 1994)	None	All patients screened on admission until end of 1993 only ^a	As phase 2	As phase 1

Isolation details: Current and previous MRSA patients cohorted on 4-bed bays (from 17 Dec. 1992) regardless of swab results. 3 single rooms, one of which was occupied by an MRSA patient at the start of phase 1

Screening details: Screening site: nose

Eradication details: In phase 1 systemic MRSA eradication for one HCW

Reported outcomes:

1. Incidence:

	Phase 1	Phase 2	Phase 3	Phase 4
MRSA acquisitions	1	0	2	3
MRSA carriage on admission/number of admissions	7/131	7/113	13/264	20/1260 ^a
Infections	1	0	2	0
Denominators: number of patients swabbed	125	109	130	398

Definitions: Infections: not specified. Carriage on admission: positive swabs taken prior to or within 48 h of admission

2. Point prevalence: During phase 1 numbers of positive patients declined steadily and no MRSA patients were on the ward by the end of Jan.

3. Trends: No data

Economic evaluation: Costings for staff time, mupirocin and screening given for each phase. Total costs estimated to be A\$41,205, of which A\$32,695 (79%) was attributed to screening

MRSA strain details: 8 strain types identified by PFGE. No one predominant strain, but 2 types comprised ~50% of strains. No high-level mupirocin resistance

Analysis in paper: No appropriate analysis of transmission data (Fisher's exact test used)

Major confounders and bias: Changes in screening effort and practice make interpretation of colonisation data difficult. Comparison with pre-study data (see **Notes** below) vulnerable to regression to the mean effects

What the authors conclude:

1. Outbreak was controlled after introduction of patient and NC, hand-hygiene emphasis and blanket mupirocin. Blanket mupirocin may be effective as an adjunct to patient and nurse cohorting for outbreak control
2. Blanket mupirocin used 3 times/week is effective at decreasing the incidence of MRSA infections if <10% admissions carry MRSA

continued

Assessment of authors' conclusions:

1. Conclusion implies there was reduced transmission after the intervention which occurred in phase I. However, there is nothing to suggest what proportion of cases in the cluster that provoked the intervention (prior to phase I) was associated with imported cases. There is therefore no clear evidence that transmission was reduced

2. Not shown. Data provide little evidence for differences in transmission between phases, but failure to report detailed prevalence data prevents meaningful comparisons between phases of study

Notes: Authors also compare outcome data from the study period with historical data (1987–92). Mean number of newly detected colonised patients per quarter was 6.95 over this period. However, minimal information is supplied regarding control measures in this period and the 10 MRSA cases detected between 3 and 9 Dec. 1992 provoked the series of interventions. Any such comparison is therefore of limited interest

^a Based on incomplete surveillance as admission screens stopped at end of 1993.

Study: Murray-Leisure *et al.*, 1990⁸³ **Design:** Retrospective ITS (2 phases)
Setting: General hospital **Location:** Philadelphia, PA, USA **Dates:** Mar. 1986–Oct. 1989
Population characteristics: 855 beds, but ~600 inpatients including many psychiatric and chronic care residents and 120 nursing home beds. MRSA not endemic. ICT
Stated aim of study: To describe the control of an MRSA epidemic
Major infection control changes during the study: Patient isolation, screening

	Isolation	Screening	Eradication	Other measures
Phase 1 32 months (Mar. 1986– 23 Oct. 1988)	Single rooms ^a	Contacts of MRSA patients screened from Aug. 1988	Topical and systemic eradication for patients	1. Gowns, gloves (masks if respiratory) 2. Handwashing education 3. Patient movement restrictions (Jan. 1988) 4. Standard antibiotic treatment (Jan. 1988) 5. 2nd infection control practitioner (Aug. 1988)
Phase 2 12 months (24 Oct. 1988–Oct. 1989)	IW	1. Contacts of MRSA patients 2. Admission screens for transfers from nursing homes and other hospitals 3. Former MRSA patients screened monthly	As phase 1	As phase 1 + 1. central vascular lines and vascular surgery avoided until MRSA eradication 2. Body substance isolation (from Jan. 1989) ³¹⁷

Isolation details: 25–30-bed IW; no overflow.^a Patients discharged from isolation ward if MRSA-negative 1 and 2 weeks after end of eradication regimen

Screening details: Sites for contact and admission screens: nose, lesions, sputum, wound, ulcer.^a Former MRSA patients screened at high risk and previously positive sites

Eradication details: Topical agents: chlorhexidine or hexachlorophene, bacitracin. Systemic agents: TMP/SMX + rifampicin or ciprofloxacin + rifampicin. More aggressive antibiotic eradication reported after Oct. 1988

Reported outcomes:

1. Incidence:

Total MRSA: Monthly incidence reported

Infections: MRSA bacteraemias: 8 in phase 1; 0 in phase 2

Colonisation: No data

MRSA carriage on admission: Monthly figures from Oct. 1988, including number screened, and number of admissions

Attributable mortality: No data

Definitions: Infection: not specified. Carriage on admission: positive admission screens

2. Point prevalence: No data

3. Trends: Low incidence of total MRSA carriage from Mar. 1986 to Oct. 1987 (0–3 cases/month). Monthly incidence increased (although not smoothly) to peak between Aug. and Oct. 1988 (12–16 cases). Incidence declined in phase 2 to 0–4 cases per month by May 1989. Numbers positive on admission (measured in phase 2 only) fell each month after Oct. 88, and were zero from January 1989 (although numbers screened were also very low)

Economic evaluation: Cost of vancomycin usage reported

MRSA strain details: No strain typing

Analysis in paper: None

Major confounders and bias: Large changes in screening and culturing. Changes in numbers positive on admission (unknown in phase 1, fall in phase 2) may be related to control at health facilities from where patients were transferred

What the authors conclude:

1. Efforts to control the outbreak without intensive surveillance and without the isolation ward were unsuccessful
2. It may be possible to control EMRSA in a large institution with limited resources and without typing

Assessment of authors' conclusions:

1. Data support conclusion, although, as the authors acknowledge, it is not possible to determine relative contributions of new acquisitions and imported cases. Therefore, it is possible, if unlikely, that initial control measures were effective at preventing spread
2. Evidence may support this but reduction in phase 2 may be related to reduction in imported cases

^a Additional information obtained from authors.

Study: Onesko and Wienke, 1987⁵⁷ **Design:** Hybrid retrospective (phase 1) and prospective (phase 2) ITS
Setting: ICU and general medical ward **Location:** St Louis, MO, USA **Dates:** Aug. 1983–July 1985
Population characteristics: 40-bed general medical ward and 10-bed ICU based in 500-bed teaching hospital. 3633 patients during study. Endemic MRSA. ICT, with 1–1.5 ICNs for the 500 beds
Stated aim of study: To determine impact of low-iodine soap on nosocomial infections, in particular those due to MRSA
Major infection control changes during the study: Handwashing agent; patient isolation

	Isolation	Screening	Eradication	Other measures
Phase 1 12 months (Aug. 1983– July 1984)	Single room	None	Eradication for selected patients only	1. Strict/contact isolation CDC guidelines 1975 ³¹⁵ 2. Non-medicated soap used 3. Povidone iodine for isolated patients 4. Handwashing education
Phase 2 12 months (Aug. 1984– July 1985)	Single room	None	As phase 1	1. Low-iodine soap replaced all other soaps 2. Handwashing education 3. Contact isolation CDC guidelines 1983 ³¹⁴

Isolation details: Single rooms assumed as contact and strict isolation. In phase 1 strict isolation before Jan. 1985

Screening details: No screening

Eradication details: No organised policy, but determined on an individual basis by patients' physicians

Reported outcomes:

1. Incidence:

Infections: Nosocomial MRSA infections/no. discharged: 25/1833 (phase 1); 5/1800 (phase 2). Time series of number of nosocomial MRSA infections per month reported for whole study. Phase 2 apparently excludes community-acquired cases. Unclear whether the same exclusions were made for phase 1, or whether same (unspecified) criteria were applied
Carriage on admission: 9 'occult community-acquired cases of MRSA' in phase 2

Denominators: Total number admissions each phase. No monthly denominators

Definitions: Infection: CDC criteria 1971.³¹⁶ Carriage on admission: not specified

2. Point prevalence: No data

3. Trends: Assuming patient discharges for each phase to be distributed equally over the months, number of infections per month ranged from 0 to 5 in phase 1 and 0 to 3 in phase 2. No obvious trend in phase 1, although cases declined in each of the last 3 months (from 5 to 1). After 1 case in the first month of phase 2, no further cases occurred for 8 months. There were then 4 cases in the last 3 months. Some evidence of a decline in the number of MSSA infections in phase 2

4. Secondary outcomes: MRSA:MSSA: 25 MSSA infections in phase 1; 5 in phase 2. Time series of nosocomial MSSA infections presented

Economic evaluation: Reduction in all nosocomial infections (including MRSA) estimated to have saved US\$109,500: \$78,000 attributed to an assumed 4-day increase in LOS of infected patients, the remainder due to delays in placing MRSA patients in nursing homes

MRSA strain details: No details given

Analysis in paper: No appropriate analysis (*t*-test used to compare MRSA incidence)

Major confounders and bias: Regression to mean

What the authors conclude: Nosocomial MRSA infection rate decreased by 80% after the change of soap, and this was assumed to be due to the greater use of soap

Assessment of authors' conclusions: Decline predated the introduction of soap by 3 months, and may therefore have been unrelated to the intervention. ICU and medical divisions selected for intervention as they had highest MRSA levels, so regression to mean likely to be important. Further interpretation difficult without prevalence data. In particular, much of phase 2 data are consistent with a prevalence of 0. Unclear why the 9 'community-acquired cases' in phase 2 were excluded if they caused infections, or how they were detected if they did not. No mention is made of exclusions of such cases in phase 1

Notes: Soap chosen for less skin irritation and for effect on *S. aureus*

Study: Oto *et al.*, 1992¹⁰¹ **Design:** Retrospective before- and after-study (2 phases)
Setting: Neonatal unit **Location:** Santiago, Chile **Dates:** 1 Dec. 1987–31 July 1988
Population characteristics: 42 beds in unit in a general hospital. All patients in neonatal unit included (487 patients). Neonates were born in maternity unit and transferred to other care rooms. Unit includes: 1 intensive care room, 4 intermediate care rooms, 1 intensive/intermediate care room, 1 minimum care room. Endemic MRSA. ICT^a
Stated aim of study: To report results of a programme to reduce levels of MRSA infection
Major infection control changes during the study: Patient isolation, eradication therapy, screening, handwashing education

	Isolation	Screening	Eradication	Other measures
Phase 1 4 months (1 Dec. 1987–Mar. 31 1988)	None	Patients screened only in last 11 days of the phase	None	None
Phase 2 4 months (1 Apr.–31 July 1988)	Cohorting on closed bays with designated nursing staff (NC)	Patients screened within 72 h of admission. Transfers from intensive care room screened. HCWs (Apr.–May and July–Aug. ^a)	Topical + systemic eradication for patients + staff	1. Handwashing education 2. Gloves, masks, aprons 3. Room cleaning

Isolation details: Intermediate care rooms (bays) used in phase 2.^a No overflow needed^a

Screening details: Sites screened: nose only for patients; nose and hands for HCWs

Eradication details: Topical agents: bacitracin and neomycin. Systemic agents: TMP/SMX

Reported outcomes:

1. Incidence:

	Phase 1	Phase 2
Total infections	30	17
Septicaemias	2	2
Pneumonias	8	2
Nasally colonised patients	16 (swabs in last 11 days of phase only)	6
Carriage on admission	No data	No data
Attributable deaths	1	1
Denominators:		
Number of patients	237	250
Number of nasal swabs	52	299

Definitions: Infection: positive cultures from tissues/fluids and adverse clinical manifestations

2. Point prevalence: No data

3. Trends: No data

4. Secondary outcomes: MRSA:MSSA In 1988 MRSA represented ~50% of *S. aureus* isolates

Economic evaluation: None

MRSA strain details: None

Analysis in paper: No appropriate analysis of incidence data (χ^2 test used)

Major confounders and bias: Design of study likely to be associated with large reporting bias. Seasonal effects possible

What the authors conclude: There was a significant reduction in MRSA disease incidence after introduction of control measures

Assessment of authors' conclusions: There was a reduction in MRSA infection, but the significance cannot be assessed with supplied data. Many potential confounders and lack of time series data prevent identification of any underlying trends

^a Additional information obtained from authors.

Study: Papia *et al.*, 1999¹⁰⁶

Design: Prospective non-comparative study

Setting: 1100-bed teaching hospital.

Location: Toronto, Canada

Dates: June 1996–May 1997

Population characteristics: MRSA initially described as endemic in hospital (4% of *S. aureus* isolates). ICT. Study population consisted of acute care patients (470 beds). Number of patients: 1742 patients screened, out of 16,646 admissions. Mean ages: 72.6 for patients MRSA-positive on admission; 63.7 MRSA-negative. Mean LOS for MRSA-positive: 24 days

Stated aim of study: To determine cost-effectiveness of screening high-risk patients for MRSA colonisation on admission

Major changes during the study: None

	Isolation	Screening	Eradication	Other measures
Phase I 12 months June 1996– May 1997	Single rooms	Admission screening (within 72 h) for high-risk patients	Attempted for patients	Handwashing emphasised. Gloves and gowns

Isolation details: All infected or colonised patients placed in private rooms

Screening details: High-risk patients defined as previously MRSA-positive; transfers from nursing homes and hospitals; and patients in nursing homes in last 3 months. Sites screened: nose, lesions, wounds, perineum, catheter exit sites. No enrichment

Eradication details: Topical mupirocin and chlorhexidine baths for all MRSA patients. Follow-up cultures taken weekly for 3 weeks, then monthly for 3 months. Clearance defined by three negative cultures 1 week apart

Reported outcomes:

1. Incidence:

Total MRSA: 64 cases detected amongst patients during study

MRSA carriage on admission: 1742^a high-risk patients had admission screens (~85% of those meeting criteria for admission screens). 23 were MRSA-positive

MRSA acquisitions: Hospital rate of nosocomial transmission of MRSA (calculated as the ratio of the number of nosocomially acquired cases to the total number of patient days for patients known to carry MRSA on admission): 0.048 transmissions/day

Definitions: MRSA carriage on admission: patients with positive swabs within 72 h of admission were considered positive on admission

2. Point prevalence: No data

3. Trends: No data

Economic evaluation: The study attempted to provide an estimate of the cost-effectiveness of a screening policy. It includes a detailed costing of the resources used to take swabs, undertake swabs and infection control measures for colonised patients. The cost of a private room is used to represent the opportunity costs of isolation. They estimated the avoided infections resulting from the introduction of the policy to be 22 assuming 0.048 transmissions per colonised patient day. The breakeven reduction required if the policy was to pay for itself was 6. Costs of contact tracing and treating an MRSA case are not included

MRSA strain details: One predominant strain found (phage type 95)

Analysis in paper: Comparison of MRSA carriage on admission between high-risk patients and others. *p*-Values reported but no methods specified so basis of calculations is not clear and cannot be assessed

Major confounders and bias: Comparison of rates of MRSA carriage on admission between high-risk patients and others likely to be subject to large detection bias due to major differences in screening practices for the two groups. Estimate of rate of nosocomial acquisition assumes all cases found ≥ 72 h after admission were newly acquired, but only 10% of patients had such admission screens. Consequently, patients positive on admission may have been misclassified as new acquisitions. Only 85% of high-risk patients screened, and this may represent a biased sample of all high-risk patients

What the authors conclude: If early identification of MRSA prevents transmission to 6 or more patients, the screening programme would save money. Prevention of a smaller number may still be cost-effective

Assessment of authors' conclusions: Authors' conclusion is not justified by the data. Conclusions are based on the tacit assumption that estimated costs for an MRSA-colonised patient were attributable only to MRSA. In fact, they include costs that other patients would also incur, such as nursing costs. Costs estimates will also be sensitive to LOS, and it is not known how much longer patients stay as a result of MRSA. Much of the estimated cost is also attributable to lost revenue due to use of private rooms that could be occupied by patients with supplemental private insurance coverage (assumed to be 40% of patients using private rooms), so external validity of conclusions may be very limited. Costs of implementing infection control procedures for MRSA patients appear to be based on arbitrary assumptions. Estimates of the costs of the screening programme, however, appear to be sound

Notes: Results of case-control study not considered here. Paper also reports numbers of cases (new acquisitions and otherwise) for 1 year prior to and 1 year after this study, but no details of isolation and screening are for these periods and these results are therefore not considered here. Cost estimates likely to be very sensitive to local conditions

^a For this figure, and for some others, values reported in the text disagree with those from the abstract. Except for the dates of the study, the values in the main text have been assumed to be correct.

Study: Pearman *et al.*, 1985⁹⁸ **Design:** Retrospective ITS (3 phases)
Setting: Teaching hospital **Location:** Perth, Australia **Dates:** Jan. 1982–June 1984
Population characteristics: 955 beds. Mean age of MRSA patients: 54 (range 16–91). MRSA not endemic. ICT, with 2 half-time ICNs
Stated aim of study: To describe an outbreak and control measures taken to terminate it and to prevent further outbreaks
Major infection control changes during the study: Patient isolation and screening

	Isolation	Screening	Eradication	Other measures
Phase 1 5 months (1 Jan.–31 May 1982)	Single rooms ^a	Contacts of MRSA patients (HCWs and patients). Weekly screens for HCWs treating MRSA patients	Attempted for staff carriers and patients undergoing long treatment in selected units	Staff MRSA carriers kept off work until treated
Phase 2 1 month (1–30 June 1982)	Single rooms ^a for MRSA patients and patients from outside Western Australia awaiting screening results	As phase 1 + admission/starting screens for patients/HCWs having been in hospitals outside Western Australia in preceding 12 months	As phase 1	As phase 1 + New HCWs allowed to start work only if shown not to carry MRSA
Phase 3 24 month (1 July 1982–June 1984)	IW ^a for known MRSA patients. Single rooms for overflow patients from outside Western Australia awaiting screening results ^a	As phase 2 (+ additional screenings sites)	As phase 1	As phase 2

Isolation details: Phases 1 and 2: no overflow. Phase 3: IW contained 5 beds, all in single rooms

Screening details: Screening sites: nose, perineum, wound, lesions. Additional sites from July 1982: hands, wrists (patients and HCWs), throat, mouth, CSU (patients)

Eradication details: Eradication also for patients carrying MRSA on transfer to other hospitals or nursing homes. Systemic treatment used if topical treatment failed. Topical agents: chlorhexidine or hexachlorophane. Systemic agents: rifampicin + fusidic acid. Clearance defined by 3 negative swabs \geq 24 hours, the first \geq 3 days post-treatment

Reported outcomes:

1. Incidence:

Total MRSA: Monthly incidence of patients colonised or infected with MRSA (including cases detected postdischarge).

59 patients colonised or infected with MRSA during study

Infections: 24 patients with MRSA infections during study

Colonisation: 35 patients with MRSA colonisation during study

MRSA carriage on admission: Monthly incidence reported. Total patient carriers detected on admission: 33 (28 had been in hospitals outside W. Australia in previous 12 months; 4 had MRSA detected in other Perth hospitals and were transferred)

Attributable deaths: No data

Denominators: None

Definitions: Infection: local state criteria.³¹⁸ Carriage on admission: figures based on admission or preadmission swabs performed on selected patients. For patients with no such swabs, no distinction between imported and newly acquired cases

2. Point prevalence: No data

3. Trends: Total monthly MRSA incidence in patients showed a cluster in May–July 1982 (5, 9 and 5 cases); otherwise only sporadic cases were seen (\leq 2 cases/month). Detected patients carrying MRSA on admission increased with time

4. Secondary outcomes: *HCW carriage:* 9 cases detected, including 1 detected at application for employment

Economic evaluation: A\$920 per annum for selective medium (~330 plates per month) reported as the only major expense

MRSA strain details: Outbreak strain resistant to tetracycline, erythromycin, gentamicin, clindamycin. Lysed by phage 88

Analysis in paper: None

Major confounders and bias: Large reporting bias expected with this type of small outbreak report with successful outcome

What the authors conclude: An MRSA outbreak can be terminated by nursing MRSA patients on a separate isolation unit

Assessment of authors' conclusions: There is some support for the conclusion, in that the number of new cases decreased and the outbreak ended only after the IW was opened. However, this was a small outbreak and stochastic fadeout provides a plausible explanation. Changes in numbers detected carrying MRSA may reflect changes in screening policy

Notes: Isolation unit commissioned in 1981 but first used for MRSA patients in July 1982^a

^a Additional information obtained from authors.

Study: Pfaller *et al.*, 1991¹¹² **Design:** Phase 1: prospective non-comparative study. Phase 2: outbreak report (reported only because there was a cluster of cases)

Setting: General hospital **Location:** Iowa, USA. **Dates:** 18 June 1985–30 Aug. 1985

Population characteristics: 327 beds. Mean LOS: 9.0 days. ~10,000 admissions/year

Stated aim of study: To estimate the point prevalence, source and nosocomial acquisition of MRSA. To describe the association between MRSA subtypes found during the study and in a subsequent cluster

Major infection control changes during the study: Changes to patient isolation and screening

	Isolation	Screening	Eradication	Other measures
Phase 1 1 month (18 June–17 July 1985)	Single-room isolation	All patients in medical and surgical services screened (nose only) at start of phase and on admission and discharge. Admission screening for patients with previous MRSA, and transfers from chronic care centres with MRSA	No details	Handwashing education, gowns, gloves and masks for all patient care activity
Phase 2 1.5 months (18 July–30 Aug. 1985)	Cohorting and single-room isolation	Contacts (patients and carers) of MRSA patients. Admission screening for patients with previous MRSA, and transfers from chronic care centres with MRSA	No details	As phase 1 + Admissions redirected to a specific unit

Isolation details: No details

Screening details: Screening sites: nose, perineum, axillae, wounds

Eradication details: No information

Reported outcomes:

1. Incidence:

Total MRSA: 13 cases in phase 1; 11 cases in phase 2

Infections: 1 infection in phase 1; 8 infections in phase 2

Colonisation: 12 colonised patients in phase 1; 3 in phase 2

MRSA carriage on admission: 7 of 473 screened patients (~1.5%) colonised on admission in phase 1. In phase 2, 3 of the cases were known to be colonised or infected on admission

MRSA acquisitions: 4 of 473 screened patients in phase 1 acquired MRSA strains. In phase 2, 7 of the MRSA cases had had negative admission screens in phase 1, so can be considered to be new acquisitions

Denominators: 473 paired (admission and discharge) cultures in phase 1

Definitions: Infection criteria: modified CDC 1971³¹⁶

MRSA carriage on admission: positive admission swabs in phase 1

2. Point prevalence: Point prevalence of MRSA carriage at start of phase 2 (medical and surgical services): 2 out of 166 patients (1.2%). Prevalence of the phase 2 outbreak strain is reported for both phases

3. Trends: Time series too short for trends to be apparent, but there were comparable numbers of transmission events in each phase, the main difference being that in contrast to phase 1, those in phase 2 appeared to be mostly due to the same strain

4. Secondary outcomes: *HCW carriage:* No staff carriers of MRSA were found from among the 70 screened

Economic evaluation: Extra cost due to one MRSA infection estimated to be US\$7480 per patient. 55% of this was due to extra LOS. REAP typing estimated to cost \$10–30 per isolate (depending on number of isolates)

MRSA strain details: In prospective part of study (phase 1), 8 types from 11 MRSA strains were found by REAP, although antibiograms were similar. 2 isolates had no plasmids. In August outbreak (phase 2) 7 patients had the same strain (A2), two others shared another type and one other type was carried by a single patient

Analysis in paper: None

Major confounders and bias: If conceived as a comparative study, comparison with phase 1 is problematic as phase 2 was reported only **because** there was an outbreak. As a non-comparative study, phase 1 contributes valid information, although the estimate of the amount of transmission may be biased by selection of patients for screening

What the authors conclude:

1. The outbreak was controlled by strict enforcement of handwashing and patient cohorting

2. Observations emphasise value of molecular epidemiology typing as an aid to controlling nosocomial infection

Assessment of authors' conclusions:

1. Phase 1 data are consistent with a low transmission rate, suggesting that stochastic fadeout of any clusters would not be unlikely. Therefore, unclear whether phase 2 outbreak would have ended without additional control measures

2. Typing clearly provided information that could not be obtained from antibiograms alone, although it is not clear how much transmission was missed owing to plasmid loss. Not clear that additional information contributed to increased control

REAP, restriction endonuclease analysis of plasmid DNA.

Study: Ribner *et al.*, 1986¹¹⁰ **Design:** Prospective cross-over cohort study (with predefined protocol)
Setting: SICU and SIMU **Location:** Texas, USA **Dates:** Not specified
Population characteristics: Both units based in a 720-bed tertiary hospital with endemic MRSA and ICT. SICU: 32 beds, 3181 patient days during study. SIMU: 20 beds, 2205 patient days
Stated aim of study: To assess whether using modified infection control precautions appropriate to patients' sites of colonisation or infection with MRSA results in the same degree of transmission as placing all patients, colonised or infected, in strict isolation
Major infection control changes during the study: Patient isolation

	Isolation	Screening	Eradication	Other measures
SICU				
Phase 1 2 months	<i>Modified precautions</i> Masks and gloves unless: <ul style="list-style-type: none"> Colonised or infected wounds: masks, gloves, gowns and single rooms preferred Colonisation or infection of LRT or burns: strict isolation 	All patients screened weekly and after discharge	None described	
Phase 2 2 months (starting straight after phase 1)	<i>Strict isolation</i> (Masks, gloves, gowns, single rooms preferred)	As phase 1	None described	
SIMU				
Phase 3 2 months (at same time as phase 1 in SICU)	<i>Strict isolation</i>	All patients screened weekly and after discharge	None described	
Phase 4 2 months (starting straight after phase 1)	<i>Modified precautions</i>	As phase 1	None described	

Isolation details: 8 (25%) SICU beds in single rooms. All 20 SIMU beds as single rooms

Screening details: Screening sites: nose, wounds, lesions, tracheostomy sites, sputum, abnormal skin

Eradication details: No eradication described

Reported outcomes:

1. Incidence:

	Modified isolation (phases 1 and 4)	Strict isolation (phases 2 and 3)
Total MRSA acquisitions in SIMU	2	7
Total MRSA acquisitions in SICU	7	4
MRSA colonisations acquired (SICU + SIMU)	4	5
MRSA bacteraemias (SICU and SIMU)	1	2
Patient days in SICU	1535	1646
Patient days in SIMU	1145	1060

Definitions: Infection criteria: none specified

MRSA carriage on admission: positive swabs taken within 72 h of admission

2. Point prevalence: No data

3. Trends: No data

Economic evaluation: Estimated cost per patient day: strict isolation US\$40–50; modified precautions: \$5. Estimated annual savings: \$43,800. Details of calculations not supplied

MRSA strain details: None given

Analysis in paper: No appropriate analysis (χ^2 and Fisher's exact test used)

Major confounders and bias: Effects of earlier phases may have contaminated later phases. Study is also vulnerable to the existence of underlying trends (since settings were chosen in part for the high MRSA levels, a decreasing trend due to regression to the mean effects is plausible over the short time intervals considered). Together these have the potential to mask effects due to the control policy

What the authors conclude: Modified precautions can be as effective as strict isolation in preventing MRSA transmission in hospitals

Assessment of authors' conclusions: The study does not provide any evidence that modified precautions are less effective than strict isolation, although the power to detect a difference is not reported and is likely to be very low. Between phase 'contamination' could be important, and conclusions are vulnerable to the existence of underlying trends

Study: Schlünzen *et al.*, 1997¹⁰⁵**Design:** Retrospective outbreak report (ITS, 2 phases)**Setting:** General hospital**Location:** Copenhagen, Denmark**Dates:** 5 Aug.–15 Nov. 1994**Population characteristics:** 330-bed hospital. MRSA not endemic. ICT with one infection control nurse^a**Stated aim of study:** To describe an outbreak**Major infection control changes during the study:** Patient isolation changed from single rooms to cohorting on a closed bay with designated nursing staff (NC)

	Isolation	Screening	Eradication	Other measures
Phase 1 1.5 months (5 Aug.– 22 Sept.)	Side rooms (1–2 patients per room, no designated staff) ^a	Contacts of MRSA patients	Topical eradication from patients with mupirocin and chlorhexidine	Masks, gloves, aprons
Phase 2 ~2 months (22 Sept.– mid-Nov. 1994)	NC on closed bay	Contacts of MRSA patients, HCWs	As above	As above

Isolation details: No overflow required for either phase^a**Screening details:** MRSA patients screened weekly at multiple sites. Patient screening sites: nose, throat, perineum, axillae, inguinal area, tracheal secretions, wounds. Staff screening site: nose**Eradication details:** Clearance criteria: three consecutive negative swabs within 1 week \geq 48 h after end of treatment**Reported outcomes:****1. Incidence:**

	Phase 1	Phase 2
Total MRSA (number of patients)	8	0
Infections	No data	No data
Colonisation:	8	0
MRSA carriage on admission	2	0
MRSA acquisitions	6	0
Attributable mortality	1	0

2. Point prevalence: Full prevalence data reported**3. Trends:** Full timing of acquisitions reported, but number of cases too small to describe a trend**Economic evaluation:** Total cost to hospital estimated to be DKK 600,000. Staff costs associated with patient isolation: DKK 500,000. Medicine and disposables costs: DKK 90,000**MRSA strain details:** Three strain types defined by PFGE: A and B from one patient each, type C from six patients. Type C resistant to penicillin, gentamicin, cefuroxime, sulphonamide, ciprofloxacin, erythromycin, clindamycin**Analysis in paper:** None**Major confounders and bias:** Large reporting bias may be expected for short successfully controlled outbreak reports**What the authors conclude:**

1. The outbreak was only brought to an end after NC isolation measures were introduced
2. Screening multiple sites was important for control

Assessment of authors' conclusions:

1. Evidence is consistent with the hypothesis that NC contributed to control, although numbers are very small, stochastic fadeout would not have been unlikely and reporting bias may be expected with this type of report
2. Study does not allow an assessment of the importance for control of screening multiple sites, but it is clear that many carriage sites would have been missed had these not been screened

DKK, Danish Kroner.

^a Additional information obtained from authors.

Study: Selkon *et al.*, 1980⁸² **Design:** Retrospective ITS (2 phases)
Setting: 1000 bed teaching hospital **Location:** Newcastle, UK **Dates:** 1968–78
Population characteristics: ~26,500 patients admitted to hospital each year. ICT. MRSA initially epidemic
Stated aim of study: To describe the epidemic
Major changes during the study: Patient isolation, screening, and antibiotic use

	Isolation	Screening	Eradication	Other measures
Phase 1 5.5 years (1968–mid-1973)	Single rooms ^a . NC attempted but not possible owing to staff shortages ^a	Contacts of MRSA patients	Attempted for patients and HCWs	1. Ward closures 2. Barrier nursing
Phase 2 5.5 years (mid-1973–1978)	IW (for MRSA patients and contacts)	Contacts of MRSA patients. Transfers to cleared areas from non-cleared areas	As phase 1	1. Barrier nursing 2. Patient quarantine for transfers to cleared areas from non-cleared areas

Isolation details: Most side rooms exhaust ventilated^a. IW (purpose-built, 12 beds, including 8 single rooms) used for isolating patients from each department sequentially until MRSA cleared from that area

Screening details: Nasal screens cultured without enrichment

Eradication details: Topical nasal eradication with aminoglycoside, bacitracin and unspecified agent^a. HCWs also used hexachlorophane soap and bath solution^a

Reported outcomes:

1. Incidence:

Infections: Annual incidence of infections due to MRSA strains also resistant to tetracycline and/or streptomycin reported

Colonisation: No data

MRSA carriage on admission: No data

MRSA acquisitions: No data

Attributable deaths: No data

Denominators: Total deaths and discharges reported from 1972 only

Definitions: Infections: MRSA isolated from a wound suspected to be infected on clinical grounds^a

2. Point prevalence: No data

3. Trends: MRSA infections increased steadily from 37 in 1968 to peak at 177 in 1972. They subsequently declined to 14 in 1978 (despite an increase in 1976)

Secondary outcomes: Annual incidence of infections due to MSSA strains resistant to penicillin, tetracycline and streptomycin showed large fluctuations and declined each year, falling from 196 to 102/year in phase 1, but remained between 100 and 200/year throughout

Economic evaluation: No formal evaluation, but IW reported to have been considered an economical solution which avoided ward closures and allowed an uninterrupted continuation of patient services^a

MRSA strain details: Increase and later decrease in MRSA accounted for by changing prevalence of one phage type (75/85). After 1972 tetracycline resistance was no longer invariably associated with streptomycin resistance, which declined rapidly in the early 1970s, resulting in a re-definition of 'hospital staphylococci' in 1972^a

Analysis in paper: No appropriate analysis for time series data: linear regression relating MRSA incidence to time reported

Major confounders and bias: Reported though unquantified decline in tetracycline use from 1972 is an important confounder

What the authors conclude: Attempts to control MRSA failed until isolation ward opened. Subsequently there was a marked reduction in MRSA infections. The IW was effective at preventing the spread of *S. aureus* from individual patients

Assessment of authors' conclusions: Phase 1 attempts to control MRSA clearly failed, and decline in phase 2 is consistent with the assertion that the IW was effective in preventing spread. However, potentially important confounders exist, in particular changes in antibiotic use

Notes: The decrease in MRSA strains was not paralleled by a decrease in other 'hospital staphylococci', carriers of which were not isolated in the IW until near the end of the study when some evidence of decrease in these strains was seen

^a Additional information obtained from authors.

Study: Shanson *et al.*, 1976²⁸ **Design:** Retrospective outbreak report, ITS (2 phases)
Setting: Tertiary teaching hospital **Location:** London, UK **Dates:** January 1976–May 1976
Population characteristics: ~350-bed hospital^a. Outbreak restricted to two general medical and two general surgical wards. MRSA not endemic. Mean LOS: ~10 days
Stated aim of study: To report the first *S. aureus* strain resistant to gentamicin and methicillin
Major infection control changes during the study: Patient isolation and screening and educational interventions

	Isolation	Screening	Eradication	Other measures
Phase 1 ~3 months (Jan.–late-Mar. 1976) ^a	MRSA patients initially transferred to an infectious diseases unit at another site ^a Single rooms after Feb./early March ^a	Patient contacts of MRSA cases. Weekly screens for patients and HCWs in affected areas	Eradication therapy for colonised patients ^a	1. Handwashing education 2. Ward closure 3. Gloves 4. Non-touch dressing 5. Ward cleaning
Phase 2 ~1.5 months (last week in Mar.–12 May 1976)	IW	As phase 1	As phase 1	As phase 1

Isolation details: In phase 1, infectious diseases unit refused to take further cases during Feb./early Mar. IW (phase 2) had 20 beds, no single rooms.^a IW eventually closed and remaining patients transferred to medical wards with NC in separate rooms

Screening details: Site screened: nose

Eradication details: Topical agent: chlorhexidine cream. Systemic agent (used for a few patients): erythromycin^a

Reported outcomes:

1. Incidence:

Total MRSA: Phase 1: 14 cases detected in hospital (detection dates reported). Phase 2: 2 cases. (Also 2 cases detected elsewhere in phase 1 suspected to have been acquired in hospital during outbreak)

Infections: No data

Colonisation: No data

MRSA carriage on admission: None

Attributable mortality: No data

Definitions: Infection: None. Carriage on admission: all strains of common outbreak type assumed to be nosocomial except index case

2. Point prevalence: No data

3. Trends: Acquisition rate decreased substantially in phase 2. Last case occurred on 12 May. No further cases in the 6 months since all closed wards were reopened

Economic evaluation: None

MRSA strain details: One predominant strain: resistant to gentamicin, tetracycline, streptomycin, kanamycin and tobramycin. All lysed by phage 77, and most also by 29 and 55

Analysis in paper: None

Major confounders and bias: Large reporting bias expected for short reports of successfully controlled outbreaks such as this

What the authors conclude: Since the use of the infection control measures the epidemic has not returned for over 6 months

Assessment of authors' conclusions: Authors make no conclusions about effectiveness of isolation measures, but there is some support for the hypothesis that the IW contributed to control. However, observed course of outbreak would not be inconsistent with stochastic fadeout

Notes: Isolated cases were also detected at two other hospitals and a convalescent home

^a Additional information obtained from authors.

Study: Shanson *et al.*, 1985¹¹ **Design:** Retrospective observational study (1 phase)
Setting: University hospital **Location:** London, UK **Dates:** June–Sept. 1985
Population characteristics: 450-bed hospital.^a Mean LOS ~8 days.^a ICT, with 1 ICN^a
Stated aim of study: To describe an outbreak due to an epidemic strain
Major infection control changes during the study: No major changes, but a number of minor changes

	Isolation	Screening	Eradication	Other measures
Phase I 1 June–30 Sept. 1985	IW	Patient and staff contacts of MRSA cases screened when cases found on surgical ward and ICU, and weekly. ^a Patients and staff in reopened wards screened weekly for 3 weeks ^a	Eradication from staff carriers	1. Handwashing education, gloves and gowns after mid-July 2. Ward closures 3. Patient contacts of MRSA patients screening negative allowed to return to reopened cleaned wards

Isolation details: Purpose-built ventilated IW contained 18 beds (all in single rooms) and accommodated MRSA patients and burns patients for protection.^a MRSA patients in the unit were cared for by designated nursing staff only after more nurses were provided when a case of cross-infection occurred there (mid-July). Single rooms used for overflow MRSA patients when discharge was not possible^a

Screening details: Screening sites: nose, lesions (also throat, perineum, wrists, hairline for nasal MRSA cases)

Eradication details: Topical agents: pseudomonic acid. Naseptin (once). Systemic agents (once): rifampicin + fusidic acid

Reported outcomes:

1. Incidence:

Total MRSA: 15 patients

Infections: 13 infections, 0 bacteraemias

Colonisation: 2 patients with MRSA colonisation only

MRSA carriage on admission: 2 of the 15 cases were detected on readmission

Attributable mortality: No data

Denominators: 420 swabs taken from 324 patients and HCWs

Definitions: infection: not specified. Carriage on admission: all strains of common outbreak type considered true acquisitions

2. Point prevalence: Almost complete prevalence data reported

3. Trends: N/a as outbreak too short

4. Secondary outcomes: HCW MRSA: 5 colonised HCWs

Economic evaluation: None

MRSA strain details: Resistant to penicillin, tetracycline, gentamicin, erythromycin. Not typeable with routine phage

Analysis in paper: None

Major confounders and bias: stochastic fadeout would not be unlikely for such a small outbreak, and reporting bias likely to be associated with this type of report

What the authors conclude: Extensive use of the isolation unit was important for the complete control of the outbreak and early control would have been impossible without it

Assessment of authors' conclusions: Isolation unit was in continual operation throughout, and there were many other changes including ward closures and the assignment of staff to patients in the unit. Consequently, value of the unit in the control of the outbreak is not readily assessed. Furthermore, there is evidence that there was spread within the isolation unit, and from patients in the unit to those outside it

^a Additional information obtained from authors.

Study: Souweine *et al.*, 2000⁷⁸ **Design:** Retrospective before- and after-study, where comparison was not suggested by data

Setting: ICU **Location:** Clermont-Ferrand, France **Dates:** 1 May 1994–30 Apr. 1996

Population characteristics: 10 beds in ICU. 555 patients during study. Mean age: 65 (phase 1); 62 (phase 2). Mean LOS: 12.1 days (phase 1), 8.2 days (phase 2)

Stated aim of study: To determine the impact of infection control measures on colonisation and infection due to MRSA (and other nosocomial pathogens)

Major infection control changes during the study: Screening, barrier precautions (gloves, gowns), ICN visits, prompt patient discharges, handwashing education, changes in antibiotic prescribing

	Isolation	Screening	Eradication	Other measures
Phase 1 (1 May 1994– 30 Apr. 1995)	None	None	None	No recommendations for handwashing or gloves except for aseptic procedures
Phase 2 (1 May 1995– 30 Apr. 1996)	Barrier precautions (gloves and gowns)	All patients screened on admission, discharge and at weekly intervals	Mupirocin used for patients with nasal MRSA carriage	1. Imipenem use discouraged 2. Handwashing education (twice weekly ICN visits) 3. Prompt patient discharge 4. Daily chlorhexidine washes

Isolation details: No single rooms on ward^a

Screening details: Screening sites: nose, rectum

Eradication details: Clearance defined by two weekly negative surveillance cultures

Reported outcomes: Results based on clinical isolates only, and not screening swabs

1. Incidence:

	Phase 1	Phase 2
<i>Total MRSA:</i>		
MRSA infected or colonised patients	18	9
MRSA infections/colonisations per 1000 patient days	6.0	3.3
<i>Infections:</i>		
MRSA bacteraemias	4	2
MRSA pneumonias	4	1
Total MRSA-infected patients	12	6
<i>Colonisation:</i>		
Carriage on admission:	No data	No data
Attributable deaths:	No data	No data
<i>Denominators:</i>		
Number of patients	233	351

Definitions: Infection: CDC criteria 1988.³¹¹ Carriage on admission: positive swabs within 48 h of admission or other evidence of prior carriage. Clinical isolates for infections considered to be acquired outside the ICU were excluded in above outcome data

2. Point prevalence: No data

3. Trends: No data

Economic evaluation: Total antibiotic cost per patient: £98.7 (phase 1); £62.7 (phase 2), with costing for individual antibiotics

MRSA strain details: None

Analysis in paper: No appropriate analysis: χ^2 and Fisher's exact test used for comparisons between phases

Major confounders and bias: Reduced LOS in phase 2 could reduce the proportion of HAI detected during ICU stays. No patient follow-up after discharge

What the authors conclude: Infection control measures led to a significant decrease in the percentage of patients infected with MRSA

Assessment of authors' conclusions: Evidence supports conclusion, but the single data point per phase is insufficient for a proper evaluation of intervention and its significance. Total number of cases is small and changes may be consistent with stochastic fluctuations. Falling LOS, although part of the intervention, may reduce the chance of detecting infections

Notes: Infection control measures were not implemented in response to high MRSA levels

^a Additional information obtained from authors.

Study: Stone *et al.*, 1998⁷⁵ **Design:** Retrospective ITS with non-equivalent control group. 3 phases
Setting: Acute elderly care unit (3 wards) and general medical unit (4 wards^a) **Location:** London, UK **Dates:** Oct. 1994–Mar. 1996

Population characteristics: Units in a teaching hospital with endemic MRSA. Acute elderly: 66 beds over 3 wards, wards have 4-bed bays and single rooms (10 across the 3 wards). Age: ≥ 75 years. Mean LOS: 11.4 days. General medical unit: 101 beds^a. Age of MRSA patients: $\sim 50\% \geq 65$ years. LOS: 8–9 days^a

Stated aim of study: To evaluate the effect of enhanced infection control policies following IW control of an outbreak

Major infection control changes during the study: Patient isolation, antibiotic policy, staff education

	Isolation	Screening	Eradication	Other measures
Acute elderly				
Phase 1 5 months (Oct. 1994– Feb. 1995)	Single rooms and cohorting for all MRSA cases	Patient contacts of MRSA cases. Admission screens for contacts of MRSA cases; patients transferred from nursing homes, other hospitals and other countries; those with previous MRSA. HCWs screened when MRSA cases with no clear source ^a	Whenever MRSA detected in patients and HCWs ^a	Ward closures: 18-bed ward closed to new admissions for 47 days; 24-bed ward closed for 24 days ^a Gloves, aprons ^a UK guidelines 1990 ⁴¹
Phase 2 4 months (Mar.–June 1995)	IW	As phase 1	As phase 1	One ward closed to non-MRSA patients (as used as IW). Gloves, aprons ^a UK Guidelines 1990 ⁴¹
Phase 3 9 months (July 1995– Mar. 1996)	As phase 1	As phase 1	As phase 1	Low cephalosporin antibiotic policy. Handwashing education and feedback of MRSA and <i>Clostridium difficile</i> rates to HCWs. Handwashing with chlorhexidine scrub (for prolonged contact) or alcoholic chlorhexidine. Gloves, aprons ^a UK guidelines 1990 ⁴¹
General medical				
Phase 1 5 months (Oct. 1994– Feb. 1995)	Single rooms and cohorting ^a	As for acute elderly ^a	As for acute elderly ^a	Ward closures: 32-bed ward closed to new admissions for 23 days. ^a UK guidelines 1990 ⁴¹
Phase 2 4 months (Mar.–June 1995)	IW (for patients ≥ 65 years old). As phase 1 for others	As phase 1	As phase 1	UK guidelines 1990 ⁴¹
Phase 3 9 months (July 1995– Mar. 1996)	As phase 1	As phase 1	As phase 1	UK guidelines 1990 ⁴¹

Isolation details: Acute elderly: single rooms (and cohorting for overflow) used for known MRSA patients (phases 1 and 3 only), MRSA contacts, nursing home transfers and patients awaiting screening results.^a IW was converted 18-bed acute elderly ward, used for non-surgical MRSA patients ≥ 65 years old (except special cases) from whole hospital, and was able to accommodate all targeted MRSA patients^a

Screening details: Patient sites: nose, perineum, lesions, wounds, skin and indwelling devices.^a HCW sites: nose, throat, lesions^a

continued

Eradication details: Topical agents: mupirocin and chlorhexidine.^a Systemic agents: rifampicin and fusidic acid^a

Reported outcomes:

1. Incidence:

Total MRSA: Quarterly or 2 monthly incidence data for both settings. No data for phase 2

	Phase 1 (Oct. 1994–Feb. 1995)	Phase 3 (July 1995–Mar. 1996)
Acute elderly		
MRSA incidence/number of admissions	25/633	27/1392
Incidence per 100 admissions	3.95	1.94
General medical		
MRSA incidence/number of admissions	33/1916	69/3314
Incidence per 100 admissions	1.72	2.08

Infections: No data

Colonisation: No data

MRSA carriage on admission: No attempt to distinguish between newly-acquired and imported cases

2. Point prevalence: No data

3. Trends: On acute elderly unit incidence per 100 admissions increased during phase 1 from 2.00 (9 cases) in Oct.–Dec. 1994, to 8.79 (16 cases) for Jan.–Feb. 1995. In phase 3 (July 1995–Mar. 1996) incidence fell back to initial levels, with 2.14 (10 cases), 2.20 (11 cases) and 1.41 (6 cases) cases/100 admissions in each successive 3-month period. On the general medical unit there was a similar increase in incidence during phase 1: 1.04 per 100 admissions (13 cases) in the first 2 months; 3.13 (20 cases) in the last 2 months. During phase 3 (July 1995–Mar. 1996) there was again some increase in the new year with 2.02 (19), 1.35 (17) and 2.95 (33 cases) in each successive 3-month period

4. Secondary outcomes: Antibiotic use recorded on acute elderly unit, showing ~57% reduction in cephalosporins, ~76% increase aminopenicillins and 160% increase in trimethoprim following antibiotic policy in phase 3

Economic evaluation: Acute elderly bed days lost: 1164 before intervention (Oct. 1994–Feb. 1995); 513 after intervention (Oct. 1995–Feb. 1996)

MRSA strain details: One predominant strain: more than 90% of MRSA isolates were EMRSA-16

Analysis in paper: No appropriate analysis of time series data (χ^2 test used)

Major confounders and bias: Regression to mean. Seasonal effects (for evaluation of initial IW effect)

What the authors conclude:

1. Much of the initial fall is attributable to the isolation ward preventing cross-infection
2. Lower incidence was maintained on the elderly unit after the IW reverted to an elderly care ward. This did not happen in the general medical unit, which again had a rise in winter. The control policy helped maintain lower MRSA incidence

Assessment of authors' conclusions:

2. There were initial falls in total MRSA detected on both units (comparing the 2 months before phase 2 with the 3 months after), but it is impossible to determine how much is attributable to changes in new acquisitions and imported cases, respectively. Seasonal effects are also likely, and ward closures may have contributed. Also, numbers of cases are small and stochastic effects may be important
3. On the acute elderly unit, comparing only the same times of year, incidence in Oct.–Dec. in phase 3 was almost identical with that in phase 1, providing no evidence of any effect of the control policy. Only in the last 3 months of phase 3 was a reduction seen compared with phase 1 levels. Such a delayed effect could be consistent with cumulative effects of educational interventions, and the fact that no similar changes in MRSA incidence were seen in the general medical unit provides some support for the conclusion. However, the total number of cases is small, regression to mean is likely to be important and overall evidence for effect of control policy is weak

Notes: Outcomes also reported from the rest of the hospital, but general medical unit patients are described by the authors as being the most similar to those in the elderly unit, so we have considered these to be the control group

^a Additional information obtained from authors.

Study: Talon *et al.*, 1995¹⁰² **Design:** Prospective ITS (2 phases)
Setting: SICU **Location:** Besançon, France **Dates:** 6-month study. No year given
Population characteristics: 15 beds. 157 patients during study. Endemic MRSA
Stated aim of study: To assess incidence and routes of exogenous colonisation and infections caused by *S. aureus* and to evaluate mupirocin efficacy for reducing cross-colonisation
Major infection control changes during the study: Topical eradication

	Isolation	Screening	Eradication	Other measures
Phase 1 4 months (Feb.–May)	None	All patients on admission. All patients weekly	None	None
Phase 2 2 months (June–July)	None	As phase 1	Topical mupirocin for all patients, irrespective of MRSA status	None

Isolation details: No isolation

Screening details: Screening sites: nose, wounds, tracheal secretions

Eradication details: Mupirocin applied twice daily

Reported outcomes:

1. Incidence:

Total MRSA: Total nasal isolates during study: 35 in phase 1; 6 in phase 2

Infections: No data. Infections reported for all *S. aureus*, not for MRSA alone

Colonisation: No data

MRSA carriage on admission: 16 MRSA carriers detected from 157 admissions. Predominant strain (4A), introduced by 3 patients in phase 1 and 1 in phase 2

MRSA acquisitions: 21. For strain 4A, 12 acquisitions in phase 1, only 1 in phase 2

Attributable deaths: No data

Definitions: Carriage on admission: positive admission swabs

2. Point prevalence: Data for one strain (4a) only

3. Trends: Monthly data reported for strain 4a only, although time series is very short (6 points). In phase 1, prevalence and incidence highly variable (1–8 and 1–7), the prevalence falling from 8 to 2 in the month prior to the intervention. Prevalence was 2 throughout phase 2

4. Secondary outcomes: MRSA/MSSA nasal isolates: 35/18 (phase 1); 6/16 (phase 2)

Economic evaluation: None

MRSA strain details: 7 strains that were seen to spread were identified by PFGE. One (type 4A) predominated

Analysis in paper: No analysis of MRSA data

Major confounders and bias: 1. Mupirocin use may reduce the chance of detecting MRSA even if attempts are made to neutralise it. 2. Numbers colonised on admission in each phase are not reported (except for one strain). 3. Possible seasonal effects. 4. Acquisition data in both phases available for only one strain, so reporting bias is possible

What the authors conclude:

1. Mupirocin use reduced the MRSA infection and colonisation rates

2. Major spread of MRSA was due to cross-colonisation and not spread of resistant mutants

Assessment of authors' conclusions:

1. Unclear for infection-specific rate as these data are not reported. Some evidence that intervention reduced total MRSA transmission, although important confounders exist, and the time series is short and presents only a subset of the data

2. Conclusion is supported by the typing data

Notes: No patient isolation. Study included as this was a clearly defined prospective study with known isolation policy

Study: Tambic *et al.*, 1999⁹⁰

Design: Prospective non-interventional study

Setting: 220-bed teaching hospital

Location: Zagreb, Croatia

Dates: 16 Apr.–15 May 1996

Population characteristics: 7 wards studied: burns unit (13 beds); ITU (14 beds); 5 general surgical wards. MRSA initially endemic. Mean LOS: 8.1 days for study population. Minimum mean LOS was in ITU (3.4 days), maximum in burns unit (14.6 days)

Stated aim of study: To determine the extent of MRSA colonisation in HCWs and patients and evaluate importance of risk factors

Major infection control changes during the study: No changes

	Isolation	Screening	Eradication	Other measures
Phase I 1 month (16 Apr.–15 May 1996)	Cohorting on closed bays ^a	All patients screened on first and last days of study. All patients screened on discharge. HCWs screened once	None	1990 UK working party guidelines. ⁴¹ Handwashing education

Isolation details: Open bays used for cohorting when MRSA patients could not all be accommodated on closed bays^a

Screening details: HCW sites screened: nose and hands. Patients screening sites: nose; wounds and central venous catheter sites (on first and last study days). No enrichment

Eradication details: Eradication for one MRSA + nurse only^a

Reported outcomes:

1. Incidence:

Total MRSA: Number of MRSA-positive patients per 1000 admissions: 66.3. Number of MRSA-positive patients per 1000 patient days: 8.2

Infections: Total number of patients with MRSA infections during study: 20

Colonisation: Total MRSA-colonised patients (without infections): 22

MRSA carriage on admission: No data

MRSA acquisitions: No data

Denominators: 633 patients admitted during study

Infection criteria: CDC 1988³¹¹

2. Point prevalence: Point prevalence of MRSA carriage among patients in whole study population on first and last study days: 10.3 and 11.2%

Secondary outcomes: Prevalences (as a percentage of all *S. aureus*, cases per 1000 admissions, and cases per 1000 patient days) reported for whole hospital and individual wards. 22% of all *S. aureus* isolates were MRSA

3. Trends: No data

MRSA strain details: 3 distinct phenotypes (from antibiotic sensitivity profiles) and 4 distinct genotypes (based on RAPD) found. No clustering of types on wards except for burns where all three were the same type

Analysis in paper: None

Bias and confounders: No reporting of what proportion of patients were screened, so sampling biases are possible

What the authors conclude: A substantial proportion of MRSA carriers escape infection control measures if active screening is not performed

Assessment of authors' conclusions: Conclusion is supported by the evidence. Lack of clustering suggests that many patients may have carried MRSA on admission

^a Additional information obtained from authors.

Study: Ward *et al.*, 1981¹⁰⁰ **Design:** Retrospective outbreak report, ITS (2 phases)
Setting: General hospital (see **Notes** below) **Location:** Oregon, USA **Dates:** Feb. 1979–May 1979
Population characteristics: 463 beds. Outbreak restricted to two general surgical wards of 30 beds each. Mean LOS for MRSA patients: 97 days. MRSA not endemic. ICT with 1 ICN
Stated aim of study: To describe outbreak
Major infection control changes during the study: Changes to patient isolation, screening and eradication therapy

	Isolation	Screening	Eradication	Other measures
Phase 1 ~1.5 months (11 Feb.– 31 Mar. 1979)	Strict isolation with single rooms ^a	Contacts of MRSA patients (patients on same ward and HCWs with direct contact)	None	1. Removal of colonised HCWs 2. Handwashing education (from last week of phase)
Phase 2 ~1.5 months (1 Apr.–19 May 1979 ^a)	IW	As phase 1	None before May. Subsequently eradication for patients and staff	1. Removal of colonised HCWs 2. Handwashing education

Isolation details: 6 single rooms available for patient isolation in phase 1. IW (~25 beds,^a converted ward) opened (phase 2) when these were full. No overflow in phase 2^a

Screening details: Screening sites: nose only for HCWs; nose, rectum and potentially colonised sites for patients

Eradication details: Topical agent: bacitracin. Systemic agents: rifampicin, TMP/SMX (if extranasal sites)

Reported outcomes:

1. Incidence:

Total MRSA: Monthly and weekly incidence reported throughout study

Infections: No bacteraemias

Colonisations: No data

MRSA carriage on admission: No data

Attributable deaths: None

Definitions: Infection: local criteria

2. Point prevalence: No data

3. Trends: Sudden onset of new MRSA cases in mid-Feb. (5 cases); similar incidence next 2 months (8 and 11 cases); decline in May (4 cases) with no new cases after introduction of eradication therapy. During outbreak 1–4 new cases/week. No new cases reported for the 7.5 months after the last case in May

4. Secondary outcomes: HCW carriage: 5/307 (1.6%) of screened HCWs

Economic evaluation: None

MRSA strain details: One predominant strain. All isolates lysed by phage 47,54,75. Resistant to neomycin, clindamycin, nafcillin, erythromycin, ampicillin, cefoxitin

Analysis in paper: No analysis of time series data

Major confounders and bias: Reporting and seasonal bias; regression to mean

What the authors conclude:

1. Graduated introduction of routine control measures appeared ineffective in preventing spread
2. Eradication therapy for colonised HCWs and patients appeared to help control the outbreak and data suggest that HCW nasal carriage may have been important

Assessment of authors' conclusions:

1. New cases continued to appear following all control measures except the last, suggesting measures were unable to prevent all spread, although they may have reduced the amount of spread there would have been without them. No attempt to assess numbers colonised on admission, so impossible to tell how much spread really did continue
2. Termination of outbreak following eradication therapy, and fact that contact with colonised HCWs was documented in 26 of 28 patients who acquired MRSA infections provides limited suggestive evidence of causality. It is not reported how many comparable patients not acquiring MRSA on the same wards also had contacts with colonised HCWs. Numbers are low enough to suggest that stochastic fadeout would not have been unlikely

Notes: The paper reported two related outbreaks at two general hospitals (UOSC and PVAMC). UOSC did not use an IW and was therefore a low priority study and management of its outbreak has not been evaluated. PVAMC used an IW, so met the inclusion criteria. Management of this outbreak is described above. We did not consider this to be a controlled study of 2 interventions (and it was not described as such by the authors), as hospital population characteristics were very different

^a Additional information obtained from authors.

Study: Yano *et al.*, 2000¹¹⁴**Design:** Prospective cohort study with historical controls**Setting:** Surgical department**Location:** Osaka, Japan**Dates:** Intervention group: 1 Mar. 1997–28 Feb. 1998
Control group: 1 Jan. 1996–31 Dec. 1996**Population characteristics:** Only gastrointestinal surgery patients included in study. ~80 gastrointestinal surgery beds, located on two floors.^a Intervention group: 141 patients; mean (SD) age: 60.1 (10.9). Control group: 128 patients; mean (SD) age: 59.8 (11.5). ICT. Endemic MRSA**Stated aim of study:** To examine whether preoperative intranasal application of mupirocin ointment reduces postoperative infection with *S. aureus* and MRSA in upper gastrointestinal surgery patients**Major infection control changes during the study:** Mupirocin use in treatment group

	Isolation	Screening	Eradication	Other measures
Phase 1 12 months (1 Jan.–31 Dec. 1996)	Single rooms and cohorting	Preadmission screening for all study patients	Attempted when MRSA detected in potential study patients for phase 2	1. Handwashing education 2. Contact isolation
Phase 2 12 months (1 Mar. 97–28 Feb. 1998)	As phase 1	As phase 1	As phase 1 + mupirocin used for all study patients postoperatively regardless of MRSA status	As phase 1

Isolation details: ~20 single rooms^a**Screening details:** Nasal screening only**Eradication details:** Topical eradication (phase 1): povidone iodine gargle and ofloxacin aerosol. Systemic eradication (phase 1): rifampicin + baktar or minomycin. In phase 2, all patients treated nasally with mupirocin 3 times per day for 3 consecutive days from the 3rd postoperative day. Eradication defined by 3 consecutive negative swabs post-treatment**Reported outcomes:****1. Incidence:***Infections:*

	Phase 1	Phase 2
Postoperative MRSA infections	9	0
Postoperative MSSA infections	6	1
Number of patients	128	141

No data for colonisations, total MRSA, carriage on admission or attributable deaths

Definitions: Infection: CDC 1988 criteria.³¹¹ Infections within 30 days of surgery defined as postoperative.

MRSA acquisitions: assumed true acquisitions only if previous negative swabs during stay

2. Point prevalence: No data**3. Trends:** No data**Economic evaluation:** None**MRSA strain details:** No details**Analysis in paper:** No appropriate analysis; Fisher's exact test used to compare intervention and control group incidence**Major confounders and bias:** Hawthorne effects. Lack of time series data makes study vulnerable to existence of trends. Case mix: in phase 2 significantly more patients had preoperative complications**What the authors conclude:**

1. Preoperative nasal mupirocin use was found to be an effective measure to prevent postoperative infections in patients undergoing upper gastrointestinal surgery
2. There was a significant reduction in postoperative *S. aureus* and MRSA infection rates

Assessment of authors' conclusions:

1. Some evidence for effect although potential confounders exist
2. Assessments of significance assumes independence of patient outcomes, which is implausible for an infectious disease

^a Additional information obtained from authors.

Study: Yoshida *et al.*, 1995⁵⁵ **Design:** Prospective ITS (2 phases with predefined protocol)
Setting: 2 general surgical wards **Location:** Fukuoka, Japan **Dates:** Sept. 1992–Aug. 1994
Population characteristics: Only patients with gastrointestinal diseases were included in the study (994 patients). Endemic MRSA. 75 beds in the two wards. Mean age (SD) for all patients positive for any one of 4 organisms screened for: 61.8 (13.7)
Stated aim of study: To test the hypothesis that ward round order influences incidence of nosocomial infection in gastroenterological surgery patients
Major infection control changes during the study: Order of ward round changed

	Isolation	Screening	Eradication	Other measures
Phase 1 12 months (Sept. 1992– Aug. 1993)	Single rooms	None	Preoperative nasal disinfection for all patients with povidone iodine ^a	Ward round starts in postoperative rooms and proceeds to other rooms without fixed order
Phase 2 12 months (Sept. 1993– Aug. 1994)	As phase 1	As phase 1	As phase 1	Ward round moves from postoperative rooms to rooms with stable patients, and ends in MRSA isolation rooms

Isolation details: 4 single rooms^a for MRSA patients. Postoperative patients cohorted separately, with HCWs. Masks used

Screening details: No screening

Eradication details: All elective patients received preoperative nasal + throat disinfection with povidone iodine

Reported outcomes:

1. Incidence:

Total MRSA: Number of MRSA positive patients detected in each 2-week period reported

Infections: 150 infections (MRSA isolates) in phase 1; 50 in phase 2. 1 bacteraemia in phase 1; 0 in phase 2.

37 pneumonias in phase 1; 12 in phase 2

Colonisation: No data

Definitions: Infections: material submitted for culture only when an infection suspected, and all positive isolates were considered to be from infections. MRSA carriage on admission: no attempt to distinguish new cases from those colonised on admission

2. Point prevalence: No data

3. Trends: MRSA incidence was stable during the first 44 weeks, with 1–4 cases in each 2-week period (apart from weeks 11–12, which had 7 cases). No new cases in the last 8 weeks of phase 1. In phase 2, 0–2 new cases each fortnight; no clear evidence of a trend, although incidence appeared to be lower than in the first 44 weeks of phase 1

4. Secondary outcomes: MRSA isolates/MSSA isolates: 150/31 (phase 1); 50/40 (phase 2)

Economic evaluation: Changing ward round order reported to have virtually no cost

MRSA strain details: Patients acquiring MRSA soon after admission tended to have minocycline- and ofloxacin-resistant strains

Analysis in paper: No appropriate analysis. Piecewise linear regression used to model incidence data

Major confounders and bias: Changing prevalence is the major potential confounder for the interpretation of incidence data

What the authors conclude: Reordering ward round appears to help prevent nosocomial infection. Ward rounds for patients who have had gastroenterological surgery should go from compromised hosts to stable patients, then isolated patients

Assessment of authors' conclusions: There is some evidence of a sustained reduced incidence in phase 2, but it is difficult to interpret outcomes without prevalence data. Reduced incidence in phase 2 may be due to reduced prevalence resulting from prolonged period with no new cases near the end of phase 1

Notes: Study excluded patients with extraperitoneal metastases originating from gastrointestinal organs. No reasons given

^a Additional information obtained from authors.

Appendix 4

Modelling and economic equations

Model used for assessing threats to validity

The model presented in Chapter 2 for assessing threats to validity associated with reporting bias and regression to the mean is based on a simplified version of a previously described model which removes the explicit assumptions about transmission routes.⁵¹ There are two compartments: colonised patients (represented by the random variable X) and uncolonised patients (Y). Full bed occupancy in an n -bed ward is assumed, so $X = n - Y$. Other parameters are: transmission rate, β ; patient discharge rate, μ ; and the chance of a patient being colonised on admission, σ .

Transition probabilities in the model are then:

$$\begin{aligned}\Pr\{Y(t + \Delta t) = i + 1 | Y(t) = i\} &= \beta(n - i)i\Delta t + \sigma\mu(n - i)\Delta t + o(\Delta t) \\ \Pr\{Y(t + \Delta t) = i - 1 | Y(t) = i\} &= \mu i(1 - \sigma)\Delta t + o(\Delta t)\end{aligned}$$

All other transitions have probability $o(\Delta t)$. Parameters used for simulations in Chapter 2 are $\mu = 0.1 \text{ day}^{-1}$, $\sigma = 0.01$ and β varied between 0.05 and 0.2 day^{-1} .

Models used for assessing impact of an isolation policy

Base model without isolation

Variables used in the base model (without patient isolation) in Chapter 5 are as follows:

y	infected or colonised patients in the hospital
x	uninfected and uncolonised patients in hospital
x_c	uninfected and uncolonised patients in community with high admission rate
y_c	infected or colonised patients in community with high admission rate
x'_c	uninfected and uncolonised patients in community with low admission rate
y'_c	infected or colonised patients in community with low admission rate.

The total populations are given by n (number of patients in hospital), n_c recently hospitalised individuals with high readmission rate) and n'_c (recently hospitalised individuals with a lower admission rate). Other parameters are given in *Table 4* in Chapter 5.

The deterministic version of the model can be described by the set of three differential equations:

$$\frac{dy}{dt} = \beta y(n - y) - dy + \mu_H y_c + \mu_L y'_c - \mu y \quad (1)$$

$$\frac{dy_c}{dt} = \mu y - (\mu_H + d + \gamma)y_c \quad (2)$$

$$\frac{dy'_c}{dt} = \gamma y_c - (\mu_L + d)y'_c \quad (3)$$

The hospital population size is assumed to be fixed, so $x = n - y$.

It is assumed that the population of recently hospitalised individuals with high readmission rate, $n_c = x_c + y_c$, is also of constant size, as is the population with a lower admission rate, $n'_c = x'_c + y'_c$. This

requirement determines the values of x_c and x'_c and leads to the expression of the total community population size, $N_c = n_c + n'_c$:

$$N_c = \frac{(\mu_L + \gamma)\mu n}{(\mu_H + \gamma)\mu_L} \quad (4)$$

This model does not explicitly consider birth and death. Since each death can be considered to be replaced by a birth, and infants will initially be free of MRSA, mortality can be absorbed into the parameter d , the rate at which colonisation is cleared. For all practical situations the contribution of mortality to d is likely to be very small compared with that due to loss of colonisation and can be neglected.

The basic reproduction number (see Glossary), R_0 , is given by

$$R_0 = \frac{\beta n(\mu_H + d + \gamma)(\mu_L + d)}{(\mu + d)(\mu_H + d + \gamma)(\mu_L + d) - \mu\mu_H(\mu_L + d) - \gamma\mu\mu_L} \quad (5)$$

This is the product of the number of secondary cases in a single stay, r_0 , and the mean number of stays per patient while still colonised. The reproduction number for a single stay is given by: $r_0 = \beta n/(\mu + d)$. The mean number of stays while still colonised is given by $1/(1 - P)$, where P is the probability that a hospitalised colonised patient is discharged and readmitted at least once while still colonised. Thus, even though $r_0 < 1$, and there is insufficient transmission to sustain the epidemic over a short timescale, the patterns of patient readmission and the persistence of colonisation may be sufficient to allow R_0 to be > 1 , leading to an epidemic over a longer timescale.

Setting equations (1)–(3) to zero and solving gives the stable endemic prevalence, y^* :

$$y^* = n - \frac{\beta(d + \gamma + \mu_H)(d + \mu_L)(d + \mu) - \mu\mu_H(d + \mu_L) - \mu\mu_L\gamma}{\beta(d + \gamma + \mu_H)(d + \mu_L)} \quad (6)$$

provided that $R_0 > 1$. If $R_0 < 1$, then $y^* = 0$.

The instantaneous ratio of the rate of new hospital acquisitions to imported cases, η , is given by

$$\eta = \frac{\beta y(n - y)}{\mu_H y_c + \mu_L y'_c} \quad (7)$$

When $R_0 > 1$, evaluating this at the stable equilibrium values, y^* , y_c^* and y'_c , gives

$$\eta^* = \frac{(d + \mu)(d + \gamma + \mu_H)(d + \mu_L)}{\mu\mu_H(d + \mu_L) + \gamma\mu\mu_L} - 1 \quad (8)$$

which is independent of the transmission parameter, β .

Model with isolation policy

To consider the effect of the isolation policy, the above model was modified by introducing a new compartment representing hospitalised and isolated patients, z . Since patients in isolation are assumed to leave the hospital at a different (generally lower) rate, the relative proportions of individuals in the community with high and low readmission rates will now change over time, and the full set of differential equations is needed to model the system:

$$\frac{dy}{dt} = \beta xy - dy + \mu_H y_c + \mu_L y'_c - \mu y - \Phi(y, z) \quad (9)$$

$$\frac{dx}{dt} = -\beta xy + dy + \mu_H x_c + \mu_L x'_c \quad (10)$$

$$\frac{dz}{dt} = \Phi(y, z) - \mu_i z \tag{11}$$

$$\frac{dy_c}{dt} = \mu y + \mu_i(1 - \pi)z - (\mu_H + d + \gamma)y_c \tag{12}$$

$$\frac{dx_c}{dt} = \mu x + dy_c + \mu_i \pi z - (\mu_H + \gamma)x_c \tag{13}$$

$$\frac{dy'_c}{dt} = \gamma y_c - (\mu_L + d)y'_c \tag{14}$$

$$\frac{dx'_c}{dt} = \gamma x_c + dy'_c - (\mu_L + d)x'_c \tag{15}$$

Here the patient isolation rate, $\Phi(y, z)$, is a function of the number of isolated patients and the number of colonised patients; if all the isolation facilities are in use, patients can only be isolated at the rate at which patients leave the isolation beds. Thus:

$$\Phi(y, z) = \begin{cases} \varphi y & \text{if } z < n_i \\ \min(\varphi y, \mu_i n_i) & \text{if } z = n_i \end{cases}$$

This model reduces to the previous model if the number of isolation beds, n_i , or the isolation rate, φ , are set to zero.

Economic model

The model used for the economic evaluation is identical with that above, except that the compartment of hospitalised MRSA patients (y) is split into two: infected and colonised patients. Since infected patients are assumed to have longer stays, the total rate of patient discharge varies over time. To maintain a constant hospital population size requires that the admission rates μ_L and μ_H are now functions of the number of infected patients. These functions are chosen so that the rate of patient admission matches that of patient discharge. For the scenarios where colonised and infected patients are both isolated, when the isolation rate is limited (owing to lack of available beds), the relative rates of isolation of infected and colonised patients are the same as those pertaining when isolation rate was not limited by bed availability.

Cost vectors used in the economic model are given in Chapter 5.

Parameter estimation

Maximum likelihood estimates for parameters μ_L and μ_H (low and high readmission rates) and γ (rate of progression from high to low readmission rate) were obtained from the hospital data described in Chapter 5. The likelihood expression was derived by dividing all patient discharges into two classes: those without patient readmission in the time span covered by the data (censored observations); and those ending in a readmission. If t is the time in days between hospital discharge and either censoring or readmission, the contribution to the total likelihood function from each such observation is found by considering two possibilities: (i) that the patient is in a high readmission rate compartment up to time t ; (ii) that the patient moved from a high to low readmission rate compartment at some time $t' < t$. In the latter case the contribution to the likelihood is found by integrating over possible values for t' .

Combined, these considerations give contributions to the likelihood function, L , of:

$$[e^{-(\gamma+\mu_H)t} - e^{-\mu_i t}] \left(\frac{\gamma}{\mu_L - \gamma - \mu_H} \right) + e^{-(\gamma+\mu_H)t} \tag{16}$$

if censored and

$$[e^{-(\gamma+\mu_H)t} - e^{-\mu_i t}] \left(\frac{\gamma \mu_L}{\mu_L - \gamma - \mu_H} \right) + \mu_H e^{-(\gamma+\mu_H)t} \tag{17}$$

if readmitted.

This likelihood function was maximised using the *nlm* function in *R*.⁶⁶ Standard errors were estimated from the inverse Hessian matrix.

Simulation details

Deterministic models were solved numerically using the Runge–Kutta 4 method (Berkeley Madonna version 8.0.1; G Oster, R Macey, University of California at Berkeley, 2001).

Stochastic analogues of deterministic models were modelled by assuming all transitions (movements of patients between model compartments) occur as Poisson processes with hazard rates corresponding to rates in the deterministic model. For example, in the basic model without isolation the probability of one patient becoming colonised in a short interval of time, δt , approaches $\beta(n - \gamma)y\delta t$ as δt approaches zero. Patient admissions are an exception to this. When a single patient is discharged, he or she is replaced by another patient from the community selected randomly in accordance with relative population sizes and admission rates.

Stochastic models were implemented in a C++ program using standard simulation techniques.³¹⁹

Appendix 5

Recommendations for publication of MRSA outbreak reports and intervention studies

Guidelines

1. Specification of the type of report

The aim of the paper should be clearly described in the Introduction. The authors should state whether it is an outbreak report or an intervention study. The start and finish dates should be clear and the MRSA described as epidemic, endemic or epidemic becoming endemic, with definitions or evidence supporting the use of those terms given. If an outbreak report, the number of outbreaks should be stated clearly.

2. Study design

For intervention studies, protocol and power calculations should be reported. Any intervention study should be described as prospective or retrospective. If prospective it should be clearly stated whether it was a formally implemented study with a predefined protocol and end-point. Study design should be specified, whether a standard design (for example, an RCT, cohort study, case-control study, an interrupted time series) or non-standard or hybrid design. Reports of retrospective and prospective studies should make it clear whether any part of the study data either prompted the decision to report outcomes or to intervene, or whether the decision to report and comparisons to be made were decided on before looking at the data. For interrupted time series, the phases should have clearly stated start and stop dates and be explicitly defined in terms of a change in each intervention. For randomised studies, standard reporting guidelines should be adhered to.

3. Study population or setting

The setting should be described as, for example, a general hospital, tertiary or teaching hospital, ICU, medical or surgical or other ward or unit, or long-stay or rehabilitation hospital. If a general or tertiary hospital, the units involved should be listed. The number of beds in the setting should be given, together with the number of patients admitted during the study (denominator), and their age (mean or median with some measure of dispersion, such as standard deviation or inter-quartile range). LOS (mean or median with some

measure of dispersion) should be given for all patients and for all MRSA-positive patients. If available, the percentage of patients transferred from other hospitals (or wards), from abroad or admitted from nursing homes or with a previous history of MRSA should be given. The presence of an ICT and the number of ICNs available for the hospital or unit should be given.

4. Interventions in each phase

The isolation policy, screening policy, eradication policy and other interventions (for example, antibiotic restriction, hand-hygiene education or feedback, ward closures, feedback of surveillance or outcome data) should all be specified and clearly described in each phase. If possible, nurse staffing levels or work-loads should be given.

We have found a summary table of what changed in each phase useful.

Isolation policy

The main policy should be described according to intensity of isolation, that is, as 'isolation ward or unit', 'cohorting with designated nursing staff' or 'cohorting without designated nursing staff', 'side-room isolation', or 'none'. The use or non-use of gowns or aprons, gloves or masks should be specified, as this may be the only isolation policy in some settings.

- Isolation policy for overflow: it should be stated whether the capacity of the main isolation policy was sufficient to isolate all patients requiring isolation, and if not the overflow policy should be described as above.
- Patients isolated: it should be clearly stated which patient group was isolated, for example, all MRSA-positive patients, infected patients only, other selected MRSA-positive patients (e.g. those with uncontainable secretions), contacts of MRSA-positive patients, patients awaiting screening results, inter-hospital transfers and admissions from nursing homes.
- Isolation unit or ward details: it should be specified whether the unit was used only for MRSA or for other infectious disease also, and whether or not it was purpose-built with

negative-pressure ventilation. The number of beds should be stated together with the number of single rooms in the unit.

- Cohorting details: it should be stated whether cohorting was on open wards (i.e. in a geographically defined but not physically separated section of a general non-MRSA ward), or in open or closed bays.
- Side-room details: the number of side rooms potentially available to the study population should be stated and whether these had negative pressure or not.

Screening policy

This should specify who was screened (e.g. all patients, contacts, HCWs, elective admissions, inter-hospital or other transfers, patients with a history of MRSA, admission from nursing homes), when (e.g. on admission, on discharge, weekly, once per phase, once per admission) and what sites (e.g. nose, perineum, throat; wounds, sores, ulcers or skin breaks; mid-stream urine or catheter specimen of urine) were screened. This may need to be tabulated for clarity.

Eradication policy

This should specify whether eradication was attempted or not, whether it was topical or systemic or both, and which agents were used. The target group should be clearly described (e.g. 'all positive patients', 'all positive staff') and whether or not it was continued after discharge. Clearance of MRSA should be clearly defined (e.g. negative swabs for three consecutive weekly tests).

Other interventions

The presence or absence of antibiotic restrictions, hand-hygiene education, surveillance and feedback of infection or colonisation rates and use of ward closures should be stated, even if these are not the main interventions. Where an antibiotic or hand-hygiene policy has been introduced, data on compliance should be presented, or the absence of such data at least acknowledged. Where education or feedback has been used, the frequency and format should be described.

5. Typing

There should be details of culture media, including the addition of any selective antimicrobials. Local or reference typing data (bacteriophage, antibiogram or DNA methodology) should be given. We recommend that an appropriate selection of isolates be typed by a reference laboratory to confirm strain clonality, explore hypotheses of introduction and spread and allow comparison with known

epidemic or important strains. The Health Protection Agency have criteria for referral of strains to the reference laboratory.³²⁰

6. Outcomes

MRSA-related outcomes (infection, colonisation, crude or directly attributable mortality, bacteraemia, specific infections, etc.) should be expressed at a regular time interval (e.g. weekly, monthly or yearly) rather than as totals for each phase of a study. For shorter studies or outbreak reports charts indicating durations of individual patient stays and dates of MRSA detection provide more complete summaries of outcome data, although attention should be given to reporting data for both exposed patients who did not acquire MRSA in addition to data for MRSA-positive patients. Denominators such as the total number of admissions/discharges and patient days should be reported. All aggregation of data loses information, and we recommend reporting disaggregated data as far as possible. Graphical methods are particularly suitable for this.

If there is no screening policy or if there are major changes in the screening policy over the course of the study, incidence of MRSA infections should be reported as the primary outcome, as colonisation data will be incomplete owing to failure to detect asymptomatic MRSA-colonised patients. Where there is a consistent screening policy, the incidence of MRSA colonisations may be an appropriate outcome.

Prevalence of MRSA should be reported, ideally at the same time intervals as the incidence rates. If possible, the incidence of cases found to be colonised on admission should be reported at each time interval as this allows an estimate of the challenge to an institution from the community and of the amount of cross-infection in the study population.

Criteria used to define infection, directly attributable mortality and colonisation on admission should be explicitly stated.

We recommend that if an intervention has been stopped after a study, for example because of its perceived failure, or continued because of its apparent success, then follow-up data should be presented. However, if this is done for planned studies authors need to make it clear if it had not originally been the intention to report these data when the study was planned. In such cases these data should, therefore, not be used in the primary outcome assessment.

7. Economic outcomes

Ideally, an intervention study should include an economic assessment of the intervention. If this is not feasible, then some effort should be made to describe the resources used to carry out the intervention policy (e.g. bed days used, staff time, costs of investigations and treatments). Any important assumptions made should be described and the data presented in a way that would enable others to replicate the cost assessments in their own settings.

8. Bias and confounders

Measures taken to prevent bias should be considered in the study design, and reported in detail. Chapter 2 discusses such threats to validity and measures that can be taken to prevent them.

Potential bias in studies with comparison groups should be sought in the usual way with attention paid to method of allocation and possible selection bias. The possible presence of seasonal effects or changes to LOS, case mix, bed occupancy, staffing levels or workloads, MRSA strains or laboratory processing of isolates should each be formally acknowledged and preferably be recorded and adjusted for in the analysis as necessary. The same applies to antibiotic use, hand-hygiene and ward closures, unless these particular interventions are amongst those under investigation.

9. Type of analysis

Statistical advice should be sought from a statistician with epidemiological expertise (and ideally, knowledge of special issues relating to infectious diseases) prior to conducting the study. The type of analysis should be clearly described, and might include survival analysis or time series methods for interrupted time series. Procedures assuming independence of study units (chi-squared, Fisher's exact test, chi-squared tests for trend, linear regression, etc.) are likely to be inappropriate when the study units are taken as the patients. Since MRSA is infectious, outcomes in different patients will not usually be independent. However full and accurate the assessment of any intervention, accurate recording, archiving and reporting of the data are more important than a comprehensive statistical analysis. For outbreak reports, formal statistical analysis is not required, and may sometimes be inappropriate.

Checklist for referees

1. Type of report

Is it an outbreak report or an intervention study?

How many outbreaks are there?

Are the start and finish dates clear?

Is MRSA described as endemic or epidemic?

Is a definition of epidemicity or endemicity given?

Is the aim of the paper clear?

If an intervention study: what is the hypothesis?

2. Study design

Is it retrospective or prospective?

Is there a protocol with fixed start and finish dates?

Is it an RCT, CT, cohort, case control and/or ITS or other design?

3. Study population or setting

Is the hospital or ward setting described?

If the setting is a hospital are the units involved listed?

How many beds were in the hospital or unit?

How many admissions were there? (denominator)?

What were the ages of the patients?

What was the LOS (mean or median, plus dispersion) of all patients?

What was LOS of MRSA patients?

What percentage of admissions were inter-hospital transfers or NH admissions?

Was there an ICT?

How many ICNs were there? What was the extent of their other responsibilities? E.g. Community Trust or other hospitals?

4. Interventions

(a) Isolation:

Was the main policy isolation unit?

cohort with designated staff?

cohort without designated staff?

side room?

gowns or aprons, and gloves only?

none?

What was the policy for the overflow?

Who was isolated?

How many beds in the isolation ward or unit?

Was cohorting on open or closed bays?

How many side rooms were available?

(b) Screening:

Who was screened?

How often?

What sites?

(c) Eradication:

Was it carried out?

Which agents?

Which patients?

How was clearance defined?

Was it effective?

- (d) Other interventions:
- Were antibiotics restricted?
 - Was antibiotic use recorded?
 - Were there a hand-hygiene initiative?
 - Was hand-hygiene compliance measured?
 - Were ward closures used and how many?
5. Typing
- Culture details?
 - Local typing?
 - Reference laboratory typing?
6. Outcome
- Incidence of infection?
 - Incidence of colonisation? (in presence of consistent screening)
 - Prevalence?
 - Colonised on admission?
 - Denominator given?
 - Appropriate time interval?
 - Criteria for infection given?
 - Criteria for distinguishing patients colonised on admission given?
7. Economic outcomes
- Is it a formal economic study?
 - Costs broken down to basic units?
 - Assumptions explicit?
 - Was the intervention cost-effective?
8. Confounders
- Are any of the following recorded and adjusted for as potential confounders?
 - Changes to length of stay?
 - Changes to case mix?
 - Changes to bed occupancy?
 - Changes in staffing levels?
 - Changes in staffing workloads?
 - Changes in hand-hygiene?
 - Changes in antibiotic use?
 - Changes in strain type?
 - Changes in processing of isolates?
 - Changes in screening practice or frequency?
 - Seasonal effects?
- In studies with comparison groups:
- Is the allocation method clear, unbiased and concealed?
 - Is there any selection bias?
9. Type of analysis
- Statistical advice sought in planning a prospective study?
 - What analysis was used?
 - Is it appropriate?
 - Power calculations reported?

Notes

Although these guidelines might seem too detailed, they are the result of a consensus reached by a very experienced multi-disciplinary project group, after systematic review of the literature. They enable readers of papers to relate the findings and interventions to their own situation, and to understand exactly what interventions were carried out and when. They encourage the collection of adequate outcome data to facilitate comprehensive (multi-study) research, including better statistical analysis and modelling and allow fuller assessments of threats to validity.

We have avoided the use of terms such as contact or strict isolation, barrier nursing, enteric or skin precautions to describe isolation interventions, as these may not be universally understood to have the same meaning. Even when accompanied by a reference to, for example, CDC guidelines,³¹⁴ these may not be easily accessible to readers, especially outside the USA. We therefore recommend the use of more descriptive terms such as isolation ward, cohort (on a general ward) with designated staff, cohort without designated staff, single room, or use of aprons or gowns and gloves only, or none.

Similarly, we recommend avoiding description of interventions as ‘according to National Working Party Guidelines’. This provides insufficient detail and the most recent UK guidelines⁴ have in-built flexibility that requires further detail to be given in reporting an outbreak or intervention study. Terms such as ‘search and destroy’ or ‘Scutari’,^{40,279} similarly lack clarity, although they remain useful concepts in general discussion. A glossary may be helpful to avoid confusion.

The EPOC guidelines have proved particularly helpful⁷³ in providing suggestions for improving the quality of reports and studies. EPOC studies essentially cover changes in the organisation and delivery of care, and cover a variety of designs of controlled clinical trials, RCTs and ITSs. Most MRSA intervention studies describe a change in the delivery of care in an organisation or unit, and could be assessed using the EPOC criteria. Adequate characterisation of interventions, specification of their exact timing, and consideration of more appropriate statistical analysis, especially for ITS studies, have, therefore, informed our approach. Most outbreak reports or intervention studies are ITSs.

Other recommendations concerning the setting and population characteristics are aimed at

enabling readers of papers to relate what is written to their own experience. Data such as LOS, occupancy, numbers colonised on admission and prevalence help achieve this, but have an additional role in explaining intervention consisting of a package of measures.

It is intended that these recommendations should help standardise the reporting of intervention studies and outbreak reports and facilitate synthesis of results. The distinction between

planned studies (whether prospective or retrospective) and outbreak reports has often been blurred in the hospital infection literature. We hope that these guidelines will help to make the distinction clearer in future reports. Although outbreak reports are of limited value for assessing interventions, they can be important for generating hypotheses. We believe these recommendations will help readers to assess what was done and what was found in such studies.



Health Technology Assessment Programme

Prioritisation Strategy Group

Members

Chair,

Professor Kent Woods,
Director, NHS HTA Programme
& Professor of Therapeutics,
University of Leicester

Professor Bruce Campbell,
Consultant Vascular & General
Surgeon, Royal Devon & Exeter
Hospital

Dr John Reynolds, Clinical
Director, Acute General
Medicine SDU, Radcliffe
Hospital, Oxford

Professor Shah Ebrahim,
Professor in Epidemiology
of Ageing, University of
Bristol

Dr Ron Zimmern, Director,
Public Health Genetics Unit,
Strangeways Research
Laboratories, Cambridge

HTA Commissioning Board

Members

Programme Director,

Professor Kent Woods, Director,
NHS HTA Programme,
Department of Medicine and
Therapeutics, Leicester Royal
Infirmary, Robert Kilpatrick
Clinical Sciences Building,
Leicester

Chair,

Professor Shah Ebrahim,
Professor in Epidemiology of
Ageing, Department of Social
Medicine, University of Bristol,
Canyng Hall, Whiteladies
Road, Bristol

Deputy Chair,

Professor Jenny Hewison,
Professor of Health Care
Psychology, Academic Unit of
Psychiatry and Behavioural
Sciences, University of Leeds
School of Medicine, Leeds

Professor Douglas Altman,
Professor of Statistics in
Medicine, Centre for Statistics
in Medicine, Oxford University,
Institute of Health Sciences,
Cancer Research UK Medical
Statistics Group, Headington,
Oxford

Professor John Bond, Professor
of Health Services Research,
Centre for Health Services
Research, University of
Newcastle, School of Health
Sciences, Newcastle upon Tyne

Professor John Brazier, Director
of Health Economics, Sheffield
Health Economics Group,
School of Health & Related
Research, University of
Sheffield, SCHARR Regent
Court, Sheffield

Dr Andrew Briggs, Public
Health Career Scientist, Health
Economics Research Centre,
University of Oxford, Institute
of Health Sciences, Oxford

Dr Christine Clark, Medical
Writer & Consultant Pharmacist,
Cloudside, Rossendale, Lancs
and

Principal Research Fellow,
Clinical Therapeutics in the
School of Pharmacy, Bradford
University, Bradford

Professor Nicky Cullum,
Director of Centre for Evidence
Based Nursing, Department of
Health Sciences, University of
York, Research Section,
Seeborn Rowntree Building,
Heslington, York

Dr Andrew Farmer, Senior
Lecturer in General Practice,
Department of Primary Health
Care, University of Oxford,
Institute of Health Sciences,
Headington, Oxford

Professor Fiona J Gilbert,
Professor of Radiology,
Department of Radiology,
University of Aberdeen, Lillian
Sutton Building, Foresterhill,
Aberdeen

Professor Adrian Grant,
Director, Health Services
Research Unit, University of
Aberdeen, Drew Kay Wing,
Polwarth Building, Foresterhill,
Aberdeen

Professor Alastair Gray, Director,
Health Economics Research
Centre, University of Oxford,
Institute of Health Sciences,
Headington, Oxford

Professor Mark Haggard,
Director, MRC ESS Team, CBU
Elsworth House, Addenbrooke's
Hospital, Cambridge

Professor F D Richard Hobbs,
Professor of Primary Care &
General Practice, Department of
Primary Care & General
Practice, University of
Birmingham, Primary Care and
Clinical Sciences Building,
Edgbaston, Birmingham

Professor Peter Jones, Head of
Department, University
Department of Psychiatry,
University of Cambridge,
Addenbrooke's Hospital,
Cambridge

Professor Sallie Lamb, Research
Professor in Physiotherapy/Co-
Director, Interdisciplinary
Research Centre in Health,
Coventry University, Coventry

Dr Donna Lamping, Senior
Lecturer, Health Services
Research Unit, Public Health
and Policy, London School of
Hygiene and Tropical Medicine,
London

Professor David Neal, Professor
of Surgical Oncology, Oncology
Centre, Addenbrooke's Hospital,
Cambridge

Professor Tim Peters, Professor
of Primary Care Health Services
Research, Division of Primary
Health Care, University of
Bristol, Cotham House, Cotham
Hill, Bristol

Professor Ian Roberts, Professor
of Epidemiology & Public
Health, Intervention Research
Unit, London School of
Hygiene and Tropical Medicine,
London

Professor Peter Sandercock,
Professor of Medical Neurology,
Department of Clinical
Neurosciences, University of
Edinburgh, Western General
Hospital NHS Trust, Bramwell
Dott Building, Edinburgh

Professor Martin Severs,
Professor in Elderly Health
Care, Portsmouth Institute of
Medicine, Health & Social Care,
St George's Building,
Portsmouth

Dr Jonathan Shapiro, Senior
Fellow, Health Services
Management Centre, Park
House, Birmingham

Diagnostic Technologies & Screening Panel

Members

Chair,

Dr Ron Zimmern, Director of the Public Health Genetics Unit, Strangeways Research Laboratories, Cambridge

Dr Paul Cockcroft, Consultant Medical Microbiologist/Laboratory Director, Public Health Laboratory, St Mary's Hospital, Portsmouth

Professor Adrian K Dixon, Professor of Radiology, Addenbrooke's Hospital, Cambridge

Dr David Elliman, Consultant in Community Child Health, London

Dr Andrew Farmer, Senior Lecturer in General Practice, Institute of Health Sciences, University of Oxford

Dr Karen N Foster, Clinical Lecturer, Dept of General Practice & Primary Care, University of Aberdeen

Professor Jane Franklyn, Professor of Medicine, University of Birmingham

Professor Antony J Franks, Deputy Medical Director, The Leeds Teaching Hospitals NHS Trust

Mr Tam Fry, Honorary Chairman, Child Growth Foundation, London

Dr Susanne M Ludgate, Medical Director, Medical Devices Agency, London

Dr William Rosenberg, Senior Lecturer and Consultant in Medicine, University of Southampton

Dr Susan Schonfield, CPHM Specialised Services Commissioning, Croydon Primary Care Trust

Dr Margaret Somerville, Director of Public Health, Teignbridge Primary Care Trust, Devon

Mr Tony Tester, Chief Officer, South Bedfordshire Community Health Council, Luton

Dr Andrew Walker, Senior Lecturer in Health Economics, University of Glasgow

Professor Martin J Whittle, Head of Division of Reproductive & Child Health, University of Birmingham

Dr Dennis Wright, Consultant Biochemist & Clinical Director, Pathology & The Kennedy Galton Centre, Northwick Park & St Mark's Hospitals, Harrow

Pharmaceuticals Panel

Members

Chair,

Dr John Reynolds, Clinical Director, Acute General Medicine SDU, Oxford Radcliffe Hospital

Professor Tony Avery, Professor of Primary Health Care, University of Nottingham

Professor Iain T Cameron, Professor of Obstetrics & Gynaecology, University of Southampton

Mr Peter Cardy, Chief Executive, Macmillan Cancer Relief, London

Dr Christopher Cates, GP and Cochrane Editor, Bushey Health Centre, Bushey, Herts.

Mr Charles Dobson, Special Projects Adviser, Department of Health

Dr Robin Ferner, Consultant Physician and Director, West Midlands Centre for Adverse Drug Reactions, City Hospital NHS Trust, Birmingham

Dr Karen A Fitzgerald, Pharmaceutical Adviser, Bro Taf Health Authority, Cardiff

Professor Alastair Gray, Professor of Health Economics, Institute of Health Sciences, University of Oxford

Mrs Sharon Hart, Managing Editor, *Drug & Therapeutics Bulletin*, London

Dr Christine Hine, Consultant in Public Health Medicine, Bristol South & West Primary Care Trust

Professor Robert Peveler, Professor of Liaison Psychiatry, Royal South Hants Hospital, Southampton

Dr Frances Rotblat, CPMP Delegate, Medicines Control Agency, London

Mrs Katrina Simister, New Products Manager, National Prescribing Centre, Liverpool

Dr Ken Stein, Senior Lecturer in Public Health, University of Exeter

Professor Terence Stephenson, Professor of Child Health, University of Nottingham

Dr Richard Tiner, Medical Director, Association of the British Pharmaceutical Industry, London

Professor Dame Jenifer Wilson-Barnett, Head of Florence Nightingale School of Nursing & Midwifery, King's College, London

Therapeutic Procedures Panel

Members

Chair,

Professor Bruce Campbell,
Consultant Vascular and
General Surgeon, Royal Devon
& Exeter Hospital

Dr Mahmood Adil, Head of
Clinical Support & Health
Protection, Directorate of
Health and Social Care (North),
Department of Health,
Manchester

Professor John Bond, Head of
Centre for Health Services
Research, University of
Newcastle upon Tyne

Mr Michael Clancy, Consultant
in A & E Medicine,
Southampton General Hospital

Dr Carl E Counsell, Senior
Lecturer in Neurology,
University of Aberdeen

Dr Keith Dodd, Consultant
Paediatrician, Derbyshire
Children's Hospital, Derby

Professor Gene Feder, Professor
of Primary Care R&D, Barts &
the London, Queen Mary's
School of Medicine and
Dentistry, University of London

Ms Bec Hanley, Freelance
Consumer Advocate,
Hurstpierpoint, West Sussex

Professor Alan Horwich,
Director of Clinical R&D, The
Institute of Cancer Research,
London

Dr Phillip Leech, Principal
Medical Officer for Primary
Care, Department of Health,
London

Mr George Levy, Chief
Executive, Motor Neurone
Disease Association,
Northampton

Professor James Lindesay,
Professor of Psychiatry for the
Elderly, University of Leicester

Dr Mike McGovern, Senior
Medical Officer, Heart Team,
Department of Health, London

Dr John C Pounsford,
Consultant Physician, North
Bristol NHS Trust

Professor Mark Sculpher,
Professor of Health Economics,
Institute for Research in the
Social Services, University of
York

Dr L David Smith, Consultant
Cardiologist, Royal Devon &
Exeter Hospital

Professor Norman Waugh,
Professor of Public Health,
University of Aberdeen

Expert Advisory Network

Members

Mr Gordon Aylward,
Chief Executive,
Association of British Health-
Care Industries, London

Ms Judith Brodie,
Head of Cancer Support
Service, Cancer BACUP, London

Mr Shaun Brogan,
Chief Executive, Ridgeway
Primary Care Group, Aylesbury,
Bucks

Ms Tracy Bury,
Project Manager, World
Confederation for Physical
Therapy, London

Mr John A Cairns,
Professor of Health Economics,
Health Economics Research
Unit, University of Aberdeen

Professor Howard Stephen Cuckle,
Professor of Reproductive
Epidemiology, Department of
Paediatrics, Obstetrics &
Gynaecology, University of
Leeds

Professor Nicky Cullum,
Director of Centre for Evidence
Based Nursing, University of York

Dr Katherine Darton,
Information Unit, MIND – The
Mental Health Charity, London

Professor Carol Dezateaux,
Professor of Paediatric
Epidemiology, London

Professor Martin Eccles,
Professor of Clinical
Effectiveness, Centre for Health
Services Research, University of
Newcastle upon Tyne

Professor Pam Enderby,
Professor of Community
Rehabilitation, Institute of
General Practice and Primary
Care, University of Sheffield

Mr Leonard R Fenwick,
Chief Executive, Newcastle
upon Tyne Hospitals NHS Trust

Professor David Field,
Professor of Neonatal Medicine,
Child Health, The Leicester
Royal Infirmary NHS Trust

Mrs Gillian Fletcher,
Antenatal Teacher & Tutor and
President, National Childbirth
Trust, Henfield, West Sussex

Ms Grace Gibbs,
Deputy Chief Executive,
Director for Nursing, Midwifery
& Clinical Support Servs., West
Middlesex University Hospital,
Isleworth, Middlesex

Dr Neville Goodman,
Consultant Anaesthetist,
Southmead Hospital, Bristol

Professor Robert E Hawkins,
CRC Professor and Director of
Medical Oncology, Christie CRC
Research Centre, Christie
Hospital NHS Trust, Manchester

Professor F D Richard Hobbs,
Professor of Primary Care &
General Practice, Department of
Primary Care & General
Practice, University of
Birmingham

Professor Allen Hutchinson,
Director of Public Health &
Deputy Dean of SCHARR,
Department of Public Health,
University of Sheffield

Professor Rajan Madhok,
Medical Director & Director of
Public Health, Directorate of
Clinical Strategy & Public
Health, North & East Yorkshire
& Northern Lincolnshire Health
Authority, York

Professor David Mant,
Professor of General Practice,
Department of Primary Care,
University of Oxford

Professor Alexander Markham,
Director, Molecular Medicine
Unit, St James's University
Hospital, Leeds

Dr Chris McCall,
General Practitioner, The
Hadleigh Practice, Castle
Mullen, Dorset

Professor Alistair McGuire,
Professor of Health Economics,
London School of Economics

Dr Peter Moore,
Freelance Science Writer,
Ashtead, Surrey

Dr Andrew Mortimore,
Consultant in Public Health
Medicine, Southampton City
Primary Care Trust

Dr Sue Moss,
Associate Director, Cancer
Screening Evaluation Unit,
Institute of Cancer Research,
Sutton, Surrey

Professor Jon Nicholl,
Director of Medical Care
Research Unit, School of Health
and Related Research,
University of Sheffield

Mrs Julietta Patnick,
National Co-ordinator, NHS
Cancer Screening Programmes,
Sheffield

Professor Chris Price,
Visiting Chair – Oxford, Clinical
Research, Bayer Diagnostics
Europe, Cirencester

Ms Marianne Rigge,
Director, College of Health,
London

Professor Sarah Stewart-Brown,
Director HSRU/Honorary
Consultant in PH Medicine,
Department of Public Health,
University of Oxford

Professor Ala Szczepura,
Professor of Health Service
Research, Centre for Health
Services Studies, University of
Warwick

Dr Ross Taylor,
Senior Lecturer, Department of
General Practice and Primary
Care, University of Aberdeen

Mrs Joan Webster,
Consumer member, HTA –
Expert Advisory Network

Feedback

The HTA Programme and the authors would like to know your views about this report.

The Correspondence Page on the HTA website (<http://www.ncchta.org>) is a convenient way to publish your comments. If you prefer, you can send your comments to the address below, telling us whether you would like us to transfer them to the website.

We look forward to hearing from you.